



A Practical Handbook for Professionals Working
in Health Emergencies Internationally

In Control



ISBN: 978-3-89606-307-6

DOI: 10.25646/7125



Imprint

In Control

A Practical Handbook for Professionals Working in Health Emergencies Internationally.

© 2020 Robert Koch Institute (RKI), Berlin

Please cite this publication as: Lauffer S. and Walter J., *In Control. A Practical Handbook for Professionals Working in Health Emergencies Internationally*. Robert Koch Institute. Berlin, 2020

ISBN: 978-3-89606-307-6 DOI: 10.25646/7125

Edited by

Silva Lauffer and Jonathan Walter

Design

Albert Gehret: Layout, typesetting, chapter illustrations

Ulf Seissenschmidt: Infographics & adaptations, digital content

Print

DBM Druckhaus Berlin-Mitte GmbH

Contact

Robert Koch Institute

Nordufer 20

13353 Berlin

www.rki.de

www.incontrol-handbook.org

Disclaimer

External contributions do not necessarily reflect the opinions of the Robert Koch Institute.

Foreword

Dear reader

The greatest risk to persons engaging in international medical emergency response is poor preparation.

The *In Control* handbook hopes to provide a remedy.

At the time of writing, we are living through the Coronavirus (COVID-19) pandemic, a health emergency that disregards physical borders, brings into focus social inequalities and affects people on every continent. This shared challenge requires unprecedented measures and the collaboration of the brightest minds to support global health protection through this crisis and beyond. Healthcare infrastructures have to be strengthened, public health capacities and processes upgraded, medical countermeasures and vaccinations found and psychosocial side-effects treated. Solidarity is the normative order of the day and the human species has to collaborate to face this invisible threat. Hiding and living in fear is not an option in this interconnected world. We have both a responsibility and an opportunity to make substantial contributions to a safer, healthier and more sustainable future for us all.

The existence of this handbook is an impressive example of solidarity. Over 50 authors from more than 15 institutes and organisations have come together voluntarily within a very short time to make their expertise available and enable cross-sectoral thinking. Knowledge is bundled, resources are combined, information gaps are filled. The *In Control* handbook is not a theoretical treatise of possible dangers, but a collection of subject-matter expertise, written by experts and practitioners who have shaped health topics over the past 20 years in the most diverse corners of the world.

The Centre for International Health Protection at the Robert Koch Institute (RKI) is collaborating with its partners and investing heavily in the build-up of operational know-how and capacity to support health crisis response abroad. This is done by preparing and enabling professionals to deploy safely across the world to assist those in need. *In Control* addresses the multi-faceted challenges of an international deployment. Readers will find not only technical medical information, but also insights into, for example, the fragility of our environment, the cultural differences that influence risk communication or the dilemmas arising from social distancing. Legal principles are highlighted, along with ethical guidance to ensure that our actions and decisions correspond to the highest moral standards.

I would like to thank all of those who are involved in the management of international medical emergencies and wish you an informative journey through this handbook.



Prof. Dr. Lothar Wieler, President, Robert Koch Institute

A handwritten signature in blue ink, which reads "LW Wieler". The signature is written in a cursive, flowing style.

Acknowledgements

We are indebted to many people for the opportunity to write this handbook, but most of all to our colleagues at the Robert Koch Institute (RKI) in general and at the Centre for International Health Protection in particular. Funding from the German Federal Ministry of Health made this endeavour possible and we are most grateful for that.

We thank the European Commission and the Center for International Peace Operations (ZIF) for granting us the right to include some extracts from previous versions of a similar *In Control* handbook, first published as part of Europe's New Training Initiative for Civilian Crisis Management (ENTRI). Contributors to those sections are Helmut Buss, Gabriela Elroy, Thomas Enke, Anna von Gall, Ted Lankester, Jesper Lund, David Meißner, Brigitta von Messling, Katja Pflückiger, David Lloyd Roberts, Dorlies Sanftenberg, Gregor Schaffrath and Svenja Wolter.

Janine Dywicky from RKI deserves special mention for her painstaking support in helping this version to its feet and providing many useful suggestions.

We greatly appreciate the support of the International Committee of the Red Cross for their kind permission to include parts of David Lloyd Roberts' book *Staying Alive*.

Special thanks must go to RKI colleagues Thurid Bahr, Charbel El Bcheraoui, Hanna-Tina Fischer, Lia-Fee Frisch, Kim Grundbacher, Roland Hassel, Iris Hunger, Wolf-Martin Körk, Thomas Kratz, Sophie Müller, Gerald Ripberger, Heide Weishaar and Lea Wende, who have supported us throughout multiple revisions with their insights and advice.

Inside In Control

By *Silva Lauffer*

The purpose of *In Control* is two-fold. The first half of the book (chapters 1 to 3) provides an overview of the international architecture and inter-disciplinary environment within which health emergency responses occur – the organisations, principles, frameworks and themes that every health professional deploying abroad should be aware of. The second half of the book (chapters 4 to 8) provides practical advice to help professionals survive and thrive during their mission – from staying healthy and coping with stress to building trust among your host community or dealing with the press.

In Control aims to impart knowledge, provoke reflection and trigger curiosity. It seeks to strengthen awareness of how disciplines overlap and it attempts to caution the reader. Caution, because while emergency response is urgent by nature, it requires those involved to be well prepared in body and mind to think through their actions and achieve lasting results while avoiding further harm.

This is a field handbook, not an academic textbook. Its layout allows the reader to quickly pick a topic of interest and gain an initial insight. It is a book to put in your pocket and browse through at the dentist, on a plane or in bed!

Chapter 1 outlines the global health architecture, introducing the reader to the wide range of different international, regional and national organisations whose mandates require them to play a role in public health emergencies.

Chapter 2 dives into the values, principles, regulations and conventions that govern the actions of anyone working in medical emergency responses.

Chapter 3 explores some of the huge diversity of themes that emergency health responders will encounter, from anthropological perspectives to zoonotic infections. It shines a light on overlaps between disciplines and focuses on specialist areas of relevance.

The more practical part of the handbook opens with chapter 4, which helps you prepare for deployment – including essential arrangements and vital things to pack before you depart.

Chapter 5 offers advice on how to stay healthy and safe during your deployment, while chapter 6 investigates how personal behaviour is linked to trust and acceptance in a host community.

Chapter 7 addresses technical issues such as map reading and communication, while chapter 8 deals with preparing to hand over to your successor and returning home.

In Control is a living tool. It was first conceived in 2011 and since then has absorbed lessons from many contributors and commentators who shared their findings with the editors. The handbook is neither complete nor perfect. As scientific research evolves and as our operating environment changes, we would ask you, the reader, to use your good judgment and flexibility when applying any knowledge you gain from this book. Subsequent editions will continue to capture new research and insights.

Contents

Preface

Foreword

Acknowledgements

Inside In Control

Chapter 1

Situating yourself within the global health architecture

29

Defining international health protection	29
The United Nations (UN)	34
World Health Organization (WHO)	35
Emergency Medical Teams (EMTs)	38
Global Outbreak Alert and Response Network (GOARN)	44
UN Office for the Coordination of Humanitarian Affairs (OCHA)	47
UN Disaster Assessment and Coordination (UNDAC)	49
Inter-Agency Standing Committee/UN cluster approach	50
UN High Commissioner for Refugees (UNHCR)	56
UN Children's Fund (UNICEF)	58
UN Development Programme (UNDP)	60
UN Resident Coordinator (RC) and UN Country Team (UNCT)	60
World Food Programme (WFP)	61
UNSGM	62
International Red Cross and Red Crescent Movement	64
International Committee of the Red Cross (ICRC)	64
International Federation of Red Cross and Red Crescent Societies (IFRC)	65
National Red Cross and Red Crescent Societies	66
Emergency response mechanisms	66
World Bank	71
Pandemic Emergency Financing Facility	72

Regional organisations	73
African Union (AU)	73
Asia-Pacific Economic Cooperation (APEC)	76
Association of Southeast Asian Nations (ASEAN)	76
Caribbean Disaster Emergency Management Agency (CDEMA)	78
Central American Integration System (SICA)	78
European Union (EU)	79
Pacific Islands Forum (PIF)	85
Shanghai Cooperation Organisation (SCO)	86
South Asian Association for Regional Cooperation (SAARC)	86
National-level health systems	88
Health systems and public health institutions	88
US Centers for Disease Control and Prevention (CDC)	91
Robert Koch Institute (RKI)	92
Public Health England/National Institute for Health Protection	94
Armed forces medical services	94
Global partnerships, philanthropists, NGOs and non-state actors	97
Global partnerships	97
Philanthropists	99
Non-Governmental Organisations (NGOs)	103
Armed non-state actors	105

Chapter 2

Values and conventions to consider

109

Ethics and morality	110
Ethics in health emergencies	112
International Health Regulations	116
Dual use	118
Sustainable Development Goals (SDGs) and SDG 3	124
The right to health and health equity	128
Child protection	132
Gender	135
Sexual exploitation and abuse	138
Do No Harm	140
The Geneva Conventions	142
Biological and chemical weapons conventions	144

Chapter 3

Taking a glimpse into the health environment 151

Anthropologists in emergencies – an introduction	152
Anthropological perspectives in health emergencies	154
Biosafety and biosecurity	165
Clinical facilities and management	175
Communication Part 1: Infodemics and misinformation	190
Communication Part 2: Guiding principles of community engagement and risk communication	195
Communication Part 3: Information management and visualisation	200
Digitalisation of health and health responses	209
Environmental risks and climate extremes	214
Environmental health in emergencies	219
Epidemiology	228
Epidemiological surveillance	231
Healthcare in fragile settings	235
Health practices and quality of health care	237
Infection prevention and control	243
Laboratory facilities and diagnostics	249
Maximum containment laboratories	253
Mobile laboratories	255
Medical logistics	260
Medical waste	268
Nutrition in humanitarian response	276
Personal protective equipment (PPE)	278
Social distancing and border controls	287
Vaccination preparedness	291
Zoonotic infections	295

Chapter 4

Preparing for deployment

301

Understanding the situation

302

Where are you going?

302

Why are you going there?

304

What should you do before departure?

305

Domestic arrangements

305

Medical arrangements

308

Professional arrangements

312

What should you pack before departure?

315

Documents and related items

316

Personal items

317

Medical preparations

320

Chapter 5

Staying healthy and safe in the field

327

Staying healthy	328
General health advice	328
Hygiene	329
Common illnesses	334
Treating infections, parasites and bites	337
Health threats when working in medical facilities (nosocomial infections)	344
Personal preparedness when working in the laboratory	345
Health advice for those responding to emerging and high consequence infectious diseases	347
Dealing with climatic extremes, environmental risks and challenges	351
Hazardous materials	353
Mental health and stress management	355
Substance abuse	370
Staying safe	374
Cybersecurity	375
At your residence, at work and during recreational time	384
Fire safety	387
On the road	391
Individual protective gear	398
Mines and explosive hazards	401

Chapter 6

How to cope with everyday reality in the field 417

Procedures and codes of conduct 419

Professional registration 419

SOPs and classification of medical teams 420

Codes of conduct and ethical principles 424

Managing communication and media relations 428

Information or infodemic? 428

Personal communication 429

Internal communication 431

Communicating in emergencies 432

Media monitoring and rebuttals 433

Cultural sensitivity and diversity 435

Respecting your host culture 435

Building trust 437

Dress codes 438

Addressing the language barrier 440

Learning the local language 440

Working with an interpreter 440

Respecting the environment 444

Reduce waste 444

Reduce emissions 447

Use resources sparingly 448

Take action, raise awareness! 453

Chapter 7

Personal technical considerations

455

Communications equipment	455
Radio	456
Mobile phones	461
Satellite communications (SATCOM)	463
Internet and computers	464
Organisations that may assist you in the field	465
Map reading and navigation	466
Maps	466
Compass	476
Global Positioning System (GPS)	480
Planning	486
Transport	492
Four-wheel drive vehicles	492
Vehicle kit & checklist	495
Unmanned aerial vehicles (UAVs)	496

Chapter 8

Handover and departure

499

Final in-country steps	499
Handover	499
Closing a programme	501
Final report	503
Mission debrief	504
Returning home	505
Medical checkup	505
Reintegration: work and family	506

Annex

Phonetic Alphabet	512
Radio procedure words	515
List of abbreviations	520
Credits & References	530
Icon. Global picture dictionary: If you can't say it, show it!	581



Chapter 1

Situating yourself within the global health architecture*

Defining international health protection

By Iris Hunger and Johanna Hanefeld

International health protection is an important aspect of public health in a global context. Public health has been defined as ‘the art and science of preventing disease, prolonging life and promoting health through the organised efforts of society’. Public health activities are targeted at populations (e.g. by conducting disease surveillance and organising health campaigns), while also providing services to individual persons, such as vaccinations, school entry screenings for kids, or personal health advice. The World Health Organization (WHO) lists ten activities that are necessary for a strong public health system. They are called Essential Public Health Operations (EPHOs) and centre

* For full credits, references and further reading on the subjects covered in this Chapter, please refer to Credits & References Chapter 1 on p. 530

around three main areas of service delivery: health protection, disease prevention and health promotion (see Figure 1.1).

Public – and individual – health can be threatened by any number of conditions and events. Whether a particular event develops into a health emergency depends not just on its nature but on the strength and resilience of the pub-

Figure 1.1 Essential Public Health Operations.

Adapted from source: see Credits and References

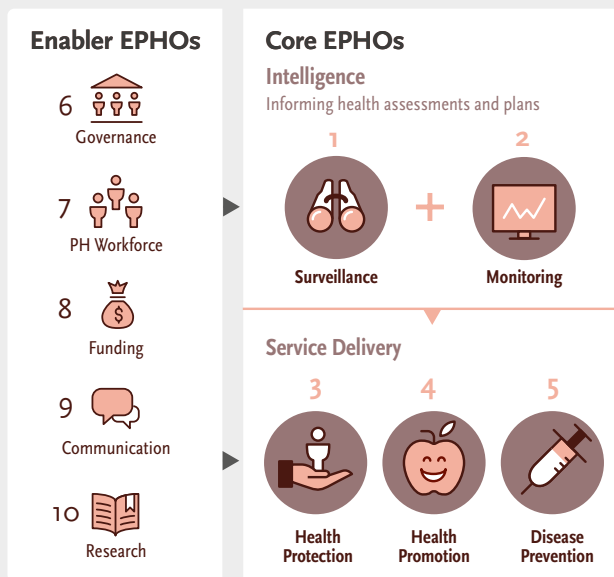

lic health and health care systems of a country, on wider systemic factors and crucially on the communities affected. Natural hazards can become ‘natural disasters’ when they hit communities that are ill-prepared and vulnerable to that hazard due to a wide range of socio-economic factors, including poverty, inequality, political marginalisation, lack of preparedness or conflict.

The following natural, accidental and intentional circumstances are highly likely to require health emergency deployments (see Figure 1.2):

- Natural hazards, such as earthquakes, floods or hurricanes, leading to injuries and deaths, sometimes followed by outbreaks of infectious diseases due to damaged water, sanitation and hygiene facilities and processes;
- Naturally occurring outbreaks of high consequence infectious diseases (HCID), mostly understood as diseases caused by risk group 4 pathogens (organisms that cause deadly disease in humans, easily travel from one person to another, and for which no treatments or vaccines exist);
- Accidental release of health-harming substances such as radioactive material, toxic chemicals or pathogens;
- Intentional release of such health-harming substances, during war, conflict or terrorist events, including the use of weapons of mass destruction.

Categories and examples of hazards and events likely to lead to health emergencies





	Natural	Accidental	Intentional
 Conventional	Earthquake, tsunami, flood, hurricane	Building collapse, train or airplane accident	Conventional war, conflict, terrorist event
 Biological	Disease outbreaks, epidemics, pandemics	Laboratory release of pathogens	Use of biological weapons
 Chemical	-	Chemical plant accident	Use of chemical weapons
 Nuclear/ Radiological	-	Nuclear power plant accident	Use of nuclear or radiological weapons

Figure 1.2

Health emergencies can affect populations at the local, national, regional or international level, most likely across these different domains. Besides the direct, short-term effects on health, they can have negative mental health consequences and longer-term consequences for the health of affected populations. They often affect the wider determinants of health such as nutrition, social security, employment and income, as well as the environment. In most cases, people already facing vulnerability – children, people with a disability, the elderly, pregnant women, and those who are ill or immunocompromised – are disproportionately affected by the consequences of health emergencies. Poverty and other factors increasing vulnerability (e.g. malnutrition, homelessness, poor housing and destitution) are major contributors to vulnerability.

Depending on their scope and scale, the needs generated by health emergencies can be addressed through local action alone or they may call for additional support from national, regional or international actors. The remainder of this chapter provides an introduction to key actors who work on issues of global health and response to health emergencies. The list of actors is not meant to be exhaustive, but it serves as a guide to the main organisations currently working in this field.

The United Nations (UN)

The United Nations (UN) was established in 1945 by 51 countries. It is committed to the maintenance or restoration of peace through international cooperation and collective security. The UN provides means for international conflict resolution and sets norms that guide the behaviour of member states. Today the UN has 193 member states that have all agreed to accept the obligations of the UN Charter.

The UN system is made up of 30 affiliated organisations and has six principal organs: the Economic and Social Council, the General Assembly, the International Court of Justice, the Secretariat, the Security Council and the Trusteeship Council.

The six principal organs, in addition to auxiliary organisations, subsidiary programmes and numerous other specialised agencies, make up the UN system. Its activities are funded through a variety of mechanisms, including assessed contributions of member states to the regular UN budget, assessed contributions to peace operations and to international criminal courts, as well as by voluntary contributions to UN funds, programmes and individual measures. Resolutions are adopted on the basis of consensus and compromise; otherwise the often-divergent interests of member states could impair decision-making processes.

World Health Organization (WHO)

The World Health Organization is the UN specialised agency for health and was established on 7 April 1948 – a date now celebrated as World Health Day.

WHO's guiding principle is that all people should enjoy the highest standard of health, regardless of race, religion, political belief, economic or social condition. Working with 194 member states, WHO's primary role is to direct and coordinate international health within the UN system. It partners with countries, the UN system, international organisations, civil society, foundations, academia and research institutions. Its main areas of work are health systems, health through the life-course, noncommunicable and communicable diseases, preparedness, surveillance and response, and corporate services.

Headquartered in Geneva, the WHO has 147 country offices and six regional offices. Each of the six regions has a regional committee made up of representatives from the region's member states. The regional committees meet every year to formulate policies, provide oversight for regional programmes, hear progress reports, and consider, revise and endorse new initiatives. They adopt resolutions and make decisions that guide the work of the regional and country offices for the coming year. The regional offices are as follows:

- WHO Regional Office for Africa (AFRO) is based in Brazzaville, Republic of Congo and serves 47 member states in the African region;
- WHO Regional Office for the Eastern Mediterranean (EMRO) is based in Cairo, Egypt and serves 21 member states and the Palestinian territories (West Bank and Gaza Strip);
- WHO Regional Office for the Americas (AMRO), also known as the Pan American Health Organization (PAHO), is based in Washington DC and covers 35 member countries across the Americas;
- WHO Regional Office for South-east Asia (SEARO) is based in New Delhi, India and covers 11 member states;
- WHO Regional Office for Europe (EURO) is based in Copenhagen and serves 53 countries, covering a vast geographical region from the Atlantic to the Pacific oceans;
- In the Western Pacific region, the WHO Regional Office for the Western Pacific (WPRO) is responsible for 37 countries and areas and is based in Manila, Philippines.

Role of WHO in emergencies

WHO's Health Emergencies Programme works with member states and other stakeholders during times of crisis

– whether caused by conflict, disease outbreak or a disaster, by providing the following services:

- support in health emergency preparedness and national plans to address critical capacity gaps;
- development of strategies and capacities to prevent and control high-threat infectious hazards;
- monitoring of new and ongoing public health events to assess, communicate and recommend action for public health risks; and,
- provide life-saving health services to affected populations in countries with ongoing emergencies.

During a crisis, WHO works with the local ministry of health and partners to identify where health needs are greatest. WHO collaborates with the following networks to leverage the expertise of partner organisations in delivering sufficient healthcare, medical supplies and personnel:

- Emergency Medical Teams
- Global Outbreak Alert and Response Network (GOARN)
- Global Health Cluster
- Global WASH Cluster
- Standby partners

For more information on these networks, see below.

Emergency Medical Teams (EMTs)

By Flavio Salio and Marie Chantal Claravall

Emergency Medical Teams (EMTs) are groups of health professionals providing direct clinical care to populations affected by disasters, disease outbreaks or emergencies as temporary surge capacity to support the local health system. The EMT network is the result of a collective effort to focus on quality care and minimum standards in emergencies, following poor responses to Haiti's devastating earthquake in 2010 and other disasters.

The term applies to clinical teams that deliver direct care, including local and international NGOs, governmental rapid response teams (national and international) and military medical teams. At the time of writing, WHO and the International Red Cross and Red Crescent Movement were finalising a memorandum of understanding to enhance collaboration between the two organisations and to recognise the Movement's Emergency Response Units (ERUs) as EMTs, compliant with EMT core standards.

Global direction and governance for the EMT network are provided by the EMT Strategic Advisory Group, which includes representation from the UN, the International Red Cross and Red Crescent Movement, selected member states and several major organisations. WHO hosts the EMT Secretariat at its headquarters in Geneva, with focal points at each WHO regional office. WHO helps to build the

capacity of national teams and coordination mechanisms, as well as convening partners to set agreed standards, assuring quality through peer review and supporting coordination during responses.

Coordination of EMTs should happen through existing emergency response frameworks. Ideally, the host government's ministry of health will coordinate EMT activities through its emergency operations centre (EOC). In many cases, an EMT coordination cell is activated.

EMT coordination is a specialised field and requires training, ideally through an accredited EMT coordination cell course or exercise. If a national focal point is not available, then a ministry of health emergency officer should be designated EMT coordinator. During an emergency, the coordinator may receive support from expert staff in WHO, international EMTs or other partners arriving in-country.

In contexts where the host government is involved in armed conflict, EMT coordination may be facilitated through a clinical case management or trauma working group acting under the health sector or another independent coordination platform.

Challenges when planning a response and attaching to a host system

The coordination of EMTs presents unique complexities, particularly during large-scale responses to sudden-onset

disasters involving support from the international community. Historically, where a high number of EMTs deployed in an uncoordinated fashion, this risked overburdening the host government and resulted in lower standards of care.

Such a risk has often been exacerbated by wide variations in the size, experience, service standards, self-sufficiency, medical capabilities, specialisations and mandates of each EMT organisation. The introduction of the *Classification and Minimum Standards for Foreign Medical Teams in Sudden Onset Disasters* (aka the 'Blue Book') in 2013 and the global EMT classification process helped address these issues.

Challenges also arise from the specific needs of an emergency-affected population. Effective EMT coordination requires more than a simple, one-dimensional matching of supply to demand (e.g. through number of hospital beds or healthcare workers per unit of population). Local needs in an emergency are influenced by many dynamic factors, including population composition and movement, the nature and phase of the emergency, the level of pre-emergency readiness, access and geographical terrain, and the cultural and ethical landscape.

When international EMTs are requested, coordination efforts must ensure their integration with the host country's existing national health system, which can vary significantly in structure, quality and capacity. Deployment of international EMTs must align with the mechanisms and methodologies used within the local context, so that those

affected can seamlessly access various types and levels of care as required by their medical condition. An example would be the smooth and timely transfer of a patient from a disaster-affected clinic to an international EMT facility for emergency surgery with appropriate, ongoing surgical follow-up and rehabilitation care after discharge back to the community, even after the departure of the international EMT.

Lastly, EMTs rely heavily on good operational support. Both national and international teams deploying into affected communities can expect substantial challenges with logistics, water, sanitation and hygiene. They must come ready to support themselves and their activities wherever possible – but they may need ongoing resupply. Managing these needs and the complexity involved in their coordination demands a high level of specialised expertise and experience.

Classifications and preparation of medical teams

In 2015, WHO launched the EMT global classification process to verify that EMT-capable organisations display the required capabilities and comply with the agreed set of principles and technical standards for EMTs, including their status of readiness for deployment (see Figure 1.3).

Emergency Medical Teams (EMT)

EMT

Daily Capacity

1

Mobile outpatient teams. Remote-area access teams for the smallest communities.



>50
outpatients

Fixed outpatient facilities +/- tented structure.



>100
outpatients

2

Inpatient facilities with surgery.



>100
outpatients



>20
inpatients

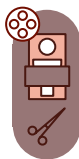

surgeries
>7
major
>15
minor

3

Referral-level care inpatient facilities, surgery and high dependency.



>100
outpatients



>40
inpatients

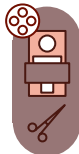

>15
major
>30
minor



4-6
intensive
care beds

+

Specialist Care

Teams that can join national facilities or EMTs to provide supplementary specialist care services.



Any direct patient care-related service can be termed a specialist cell when given in emergency response by EMT providers, such as rehabilitation, paediatric or surgery.

The EMT global classification list will contain all EMT organisations that have had their self-declared information cross-checked by a global peer review and have completed a verification visit to validate their pre-deployment capabilities. EMT quality assurance also occurs during deployment, with joint visits from the EMT coordinating entity (usually the host ministry of health) to ensure compliance with declared capabilities prior to arrival.

Global classification does not replace a host government's own process of authorising international EMTs to operate in-country, but supports it with better information on available EMTs and details of their adherence to standards, experience, capability and key contacts. Affected countries can rapidly identify and accept pre-verified EMTs, having full knowledge of their type and capabilities well in advance. In general, countries prone to natural disasters and outbreaks may also use the international EMTs' minimum standards to improve the effectiveness of the immediate response of national EMTs.

For EMT organisations, the benefits of global classification include: an expedited invitation, licensing and registration process during deployments; access to logistic support; on-site guidance; and increased confidence for donors to fund capacity building.

Global Outbreak Alert and Response Network (GOARN)

By Sandra Beermann and Evgeniya Boklage

The Global Outbreak Alert and Response Network (GOARN) is a network of institutions that collaborate to provide rapid assistance at an international level, particularly for disease outbreak response and emergencies. GOARN strengthens coordination in the alert and response to public health emergencies, via the rapid deployment of experts and provision of technical guidance when requested by WHO.

Currently there are over 250 member institutions in GOARN. To be eligible to join, organisations must have the capacity to support alert and response to public health emergencies and be not-for-profit. Experts identified through GOARN partners are deployed to the field following a request for assistance issued by GOARN. Member organisations offer a wide range of skills in, among other things, epidemiology, laboratory work, logistics, and infection prevention and control. Between 2000 and 2020, there have been more than 3,200 deployments through GOARN in support of over 95 countries.

Mission and goals of GOARN

WHO established GOARN in 1997 to bring the necessary technical expertise where required during infectious disease outbreaks and public health emergencies.

GOARN is a global technical partnership that brings together organisations and networks from 75 countries, including academic and public health institutions, ministries of health, reference laboratories, WHO regional offices and other UN agencies. The network's goals are as follows:

- Assist countries with disease control efforts by ensuring rapid and appropriate technical support to affected populations;
- Investigate and characterise events and assess risks of rapidly emerging epidemic threats;
- Support national outbreak preparedness by ensuring that responses contribute to sustained containment of epidemic threats.

The focus of the network's activities lies predominantly in response and preparedness, including an extensive network development agenda to strengthen GOARN partner capacities for response. More specifically, the GOARN operational team and secretariat coordinate the resources available within the network to engage rapid support teams, assist countries with investigation and characterisation of events, assess risks, strengthen outbreak response and facilitate national outbreak preparedness.

In 2019, the Centre for International Health Protection (ZIG) at the Robert Koch Institute in Germany became the first WHO Collaborating Centre for GOARN and supports GOARN in its activities.

GOARN 2.0 strategic plan

The complexity of many recent infectious disease outbreaks, particularly the West Africa Ebola crisis in 2014-2016, highlights the need for essential changes in WHO's approach to health emergencies. In this context, the interest in GOARN as a mechanism to support countries during such events has been growing. To address these issues, the GOARN steering committee developed a new strategic plan, GOARN 2.0, which expands the network's focus beyond deployments and includes new areas of action crucial for preparedness and response. These new areas are alert and risk assessment, training, operational research and tools, and public health rapid response capacities.

How can I apply for a GOARN mission?

In the event of an outbreak, the government of the affected country will decide whether international assistance is needed. Whenever this is the case, an international response will be activated and a formal request for support from an affected WHO member state will trigger a field response.

Next, the GOARN secretariat will issue an alert to signal an early warning and enable preparation and coordination of response planning. The launch of a GOARN mission and the terms of reference for each expert to be deployed will be agreed upon with the affected country's government. Once the alert has been issued, GOARN sends out a request for

assistance (RFA) to all partner institutions, which specifies the expertise and skills required for the outbreak response team.

Only experts affiliated with GOARN partners can offer their assistance. The standard procedure is for the institution to submit the resumés of those staff members who fulfill the requirements detailed in the RFA with regard to qualifications, experience and skills. Another important aspect is the readiness of member organisations. To provide support promptly, teams must be prepared to deploy quickly, including identifying personnel, keeping vaccinations updated and ensuring fast clearances for deployment.

It is important to mention that the ministry of health of the affected country is actively involved in the selection process and retains complete control over the outcome of the agreement about deployed personnel. After suitable candidates are selected and informed of the decision, the deployment process is initiated.

UN Office for the Coordination of Humanitarian Affairs (OCHA)

OCHA is the part of the UN Secretariat responsible for bringing together humanitarian actors to ensure a coherent response to emergencies. OCHA ensures there is a framework within which each actor can contribute to the

overall response effort. Its activities are focused around five core functions:

- **Coordination** – OCHA coordinates humanitarian response to expand the reach of humanitarian action, improve prioritisation and reduce duplication, ensuring that assistance and protection reach the people who need it most.
- **Advocacy** – OCHA raises awareness of forgotten crises, promotes respect for international humanitarian law (IHL), brings the voices of crisis-affected people to the forefront and helps people obtain access to humanitarian assistance.
- **Policy** – OCHA helps set the agenda for humanitarian sector reform and effectiveness in response and promotes the normative framework for international humanitarian action.
- **Humanitarian financing** – OCHA mobilises financing mechanisms to ensure that humanitarian needs are met and coordination mechanisms are promoted.
- **Information management** – OCHA provides information management services to the humanitarian community to inform a rapid, effective and principled response.

OCHA is also responsible for coordinating the cluster approach, covered in more detail below.

UN Disaster Assessment and Coordination (UNDAC)

The UNDAC system was originally established by the UN and the International Search and Rescue Advisory Group (INSARAG) to ensure effective coordination between national disaster management agencies and incoming search and rescue teams in sudden-onset, large-scale emergencies. Over the past quarter of a century, UNDAC has evolved and adapted to the changing requirements of the international humanitarian response system. Today, UNDAC teams are not only deployed in sudden-onset disasters, but also provide valuable support in protracted crises, technological and other types of emergencies, and are playing an increasing role as a tool and service of the UN in supporting governments in disaster response preparedness activities.

UNDAC deploys globally to ensure effective collaboration between national disaster management systems, international humanitarian response actors, bilateral responders including the military, national non-government organisations, civil society and the private sector, to name but a few.

Inter-Agency Standing Committee/ UN cluster approach

Coordination is vital in emergencies. Good coordination means less gaps and overlaps in organisations' work. It strives for a needs-based, rather than capacity-driven, response. It aims to ensure a coherent and complementary approach, identifying ways to work together for better collective results.

The basis of the current international humanitarian coordination system was set by General Assembly resolution 46/182 in December 1991. The resolution created the Inter-Agency Standing Committee (IASC), which is the longest-standing and highest-level humanitarian coordination forum. The IASC is headed by the UN's Emergency Relief Coordinator (ERC) and consists of the executive heads of 18 leading UN and non-UN organisations. Together, they work to ensure coherence of preparedness and response efforts, formulate policy and agree on priorities for strengthened humanitarian action. As part of its efforts to improve humanitarian coordination, the IASC instituted a series of reforms in 2005 that introduced new elements to improve capacity, predictability, accountability, leadership and partnership.

The most visible aspect of the 2005 reform was the creation of the 'cluster approach'. Clusters are groups of humanitarian organisations (UN and non-UN) working

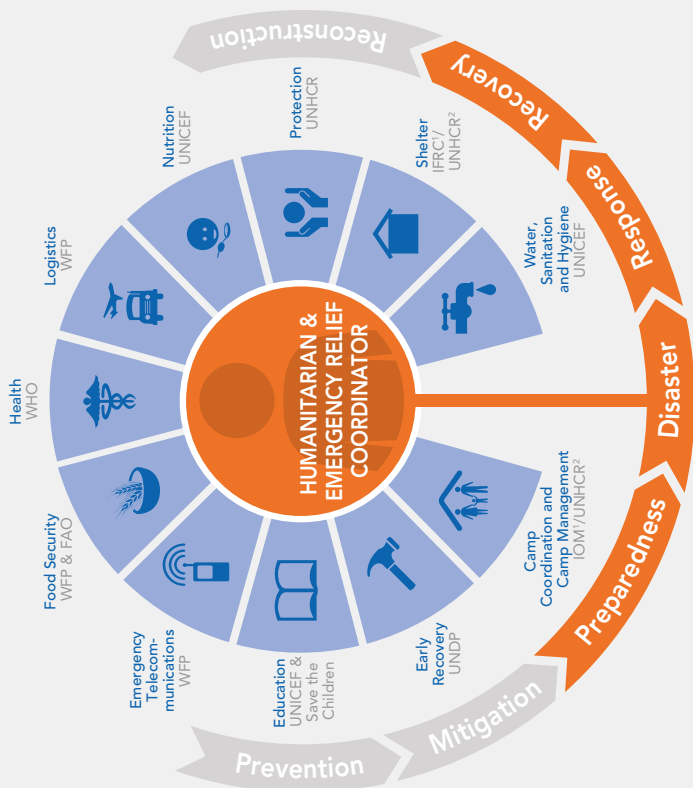

Figure 1.4 Cluster approach

Source: Inter-Agency Standing Committee (IASC)

in the main sectors of humanitarian action, e.g. shelter and health (see Figure 1.4). They are created when clear humanitarian needs exist within a sector, when there are numerous actors within sectors and when national authorities need coordination support. Clusters provide a clear point of contact and are accountable for adequate and appropriate humanitarian assistance. Clusters create partnerships between international humanitarian actors, national and local authorities, and civil society.

In 2011, the IASC ushered in a 'transformative agenda' that built on the humanitarian reform of 2005 and took into account lessons learned from humanitarian responses in 2010 and 2011, including challenges to leadership and coordination. Among other things, the agenda included protocols to set parameters for improved collective action in humanitarian emergencies (including for Level 3 system-wide emergencies) and Public Health Emergencies of International Concern (PHEIC).

OCHA works closely with global cluster lead agencies and NGOs to develop policies, coordinate inter-cluster issues, disseminate operational guidance and organise field support.

The cluster approach does not apply in refugee situations. For more information about refugee situations, refer to the UNHCR section in this chapter.

Global Health Cluster

When emergencies occur, coordination is necessary. No one organisation can respond to a health crisis alone. The Global Health Cluster (GHC) is a platform for more than 900 organisations to work in partnership to ensure collective action results in a more timely, effective and predictable response to health emergencies. WHO is designated as the cluster lead agency by the Inter-Agency Standing Committee (IASC).

The GHC is responsible for the following outputs:

- Health sector coordinating mechanisms involving UN agencies, NGOs, CBOs, health authorities, donors and community members, including between the centre and the field, and with other sectors/clusters;
- Mapping of health actors, available health services and service delivery activities;
- Information on the health situation and needs, including regular situation reports and health bulletins, based on monitoring of the situation and of the health services delivered;
- Initial rapid assessment and situation analysis, agreement on priority health problems and risks;
- Joint, regularly updated, health response strategy for the crisis, with clear priorities and objectives for addressing priority health problems, risks and gaps;

- Joint contingency plan for response to future events that could impact on the populations' health or partners' response activities;
- Distribution of responsibilities among partners based on capacities to deliver in the field;
- Agreed standards, protocols and guidelines for basic healthcare delivery, standard formats for reporting;
- Training materials and opportunities available to all partners for upgrading skills and standards of service provision, as needed;
- Agreed health sector elements in joint appeals and CERF applications; agreed priorities for allocation of pooled resources;
- Common advocacy strategy and plan;
- Joint field visits for monitoring; joint evaluations and lesson-learning.

Global WASH Cluster

The Global WASH Cluster (GWC) is a partnership of 77 organisations (at the time of writing), specialising in emergency water, sanitation and hygiene (WASH) operations. Its members come from UN agencies, international humanitarian organisations, national civil agencies and the International Red Cross and Red Crescent Movement. Formed in 2006 following the IASC-driven humanitarian reform agenda, the GWC's mandate is to improve the coordination of water, sanitation and hygiene operations during emergencies. UNICEF is designated as lead agency for the cluster, responsible for the following:

- Setting and disseminating standards and policies, including identifying best practice;
- Building response capacity by developing systems to enhance coordination, assessment and information management; and by maintaining surge capacity resources to meet unforeseen needs;
- Ensuring that national WASH cluster coordination platforms are able to access operational support and technical expertise in preparedness, response, transition and recovery;
- Pooling resources to ensure complementarity of response and to enhance partnerships;
- Advocating for increased resources where necessary.

UN High Commissioner for Refugees (UNHCR)

UNHCR was created to address the refugee crisis arising from World War Two. The 1951 Refugee Convention and its 1967 Protocol establish the scope and legal framework of the agency's work, which is to aid and protect people forced to flee their homes because of conflict and persecution. As stipulated in the 1951 Convention and the ensuing Protocols, UNHCR has the mandate to provide international protection to refugees, stateless persons, asylum seekers and returnees. This refugee mandate applies in both emergency and non-emergency situations, including in mixed movements situations involving asylum-seekers and refugees as well as migrants.

UNHCR is active in public health, providing access for refugees to life-saving and essential healthcare. This can include HIV prevention, protection and treatment, reproductive health services, food security and nutrition, and water, sanitation and hygiene services. During the COVID-19 pandemic, UNHCR strengthened its partnership with WHO to protect 70 million forcibly displaced people (including 26 million refugees) and a further 40 million internally-displaced people (IDPs) from the virus and to ensure their access to essential health services.

Refugee Coordination Model (RCM)

In lieu of the cluster approach, which does not apply in refugee settings, UNHCR uses the Refugee Coordination Model (RCM) to coordinate and deliver responses to refugee populations. Established in 2013, the RCM:

- outlines UNHCR's role and responsibilities in refugee operations and mixed displacement situations;
- provides an inclusive platform for planning and coordinating refugee operations;
- clarifies modes of coordination in relation to broader humanitarian coordination structures, including the IASC cluster system.

As part of the RCM, the UNHCR representative, the refugee coordinator and key partners, government, UN and NGOs (international and national) work together to collectively develop a contingency plan and the refugee response plan (RRP). The RRP sets out the needs of refugees and host communities, and how and by whom these needs will be addressed, including the financial requirements for all actors.

OCHA and UNHCR developed a joint note for so-called 'mixed or joint situations', where populations of humanitarian concern include those that fall under the UNHCR mandate, such as refugees, asylum seekers and returnees. This joint note sets out the roles and responsibilities of different actors, outlining how the IASC coordination structures and the RCM should practically interact with each other.

UN Children's Fund (UNICEF)

UNICEF is a UN agency that aims to improve the health, nutrition, education and general welfare of children around the world. Initially founded in 1946 to meet the emergency needs of children after World War II, UNICEF's mandate has since broadened to include development as well as humanitarian settings. UNICEF currently has offices in 192 countries and is headquartered in New York.

UNICEF's work covers a number of different sectors including child health and nutrition, safe water and sanitation, quality education and skill building, HIV prevention and treatment for mothers and babies, and the protection of children and adolescents from violence and exploitation. The organisation is guided by the Convention on the Rights of the Child (1989), which affirms the right of all children to 'the enjoyment of the highest attainable standard of health and to facilities for the treatment of illness and rehabilitation of health.'

A key part of UNICEF's mission is its work in emergency health response. During conflicts, natural disasters and other emergencies, newborns, children and mothers are often cut off from basic and essential care, including life-saving medicines and supplies. The risk of disease and malnutrition soars. And adolescents become more vulnerable to sexual violence. Today, one in four children lives in countries affected by conflict or disaster. In many of these places, more children die from diseases linked to unsafe

drinking water and sanitation than from direct violence. UNICEF works closely with governments, UN agencies and other partners to help countries prepare for and respond to emergencies.

UNICEF is designated lead agency for the Global WASH Cluster which helps coordinate emergency water, sanitation and hygiene operations. For more information on this cluster, refer to the IASC / UN cluster approach section in this chapter.

UN Development Programme (UNDP)

As the specialised agency of the UN focusing on development, UNDP has a mandate supporting countries in their development path, and coordinating the UN system at the country level. UNDP is also active in the field of crisis prevention and recovery and aims to support countries in managing conflict and disaster risks, and to rebuild for resilience once a crisis has passed. UNDP's crisis recovery work acts as a bridge between humanitarian and longer-term development efforts. UNDP focuses on building skills and capacities in national institutions and communities.

UN Resident Coordinator (RC) and UN Country Team (UNCT)

In the great majority of countries where the UN system is present, overall coordination of UN activities falls primarily to the UN Resident Coordinator (RC) in consultation with UN agencies. The RC is the designated representative of the UN Secretary-General and the position carries the same rank as an ambassador of a foreign state. The RC leads the UN Country Team (UNCT), the inter-agency coordination and decision-making body at country level. The main purpose of the UNCT is to help individual agencies to plan and work together to ensure the delivery of tangible results in support of the development agenda of the host government.

World Food Programme (WFP)

The World Food Programme was initially created at the behest of US President Eisenhower as an experiment to provide food aid through the UN system and was enshrined as a fully-fledged UN programme in 1965 to last for ‘as long as multilateral food aid is found feasible and desirable.’ Nowadays, it is assisting almost 100 million people in around 83 countries each year, delivering food assistance in emergencies and working with communities to improve nutrition and build resilience.

WFP hosts the Global Logistics Cluster which provides coordination and information management to support humanitarian emergency responses. It facilitates, where necessary, access to common logistics services, offers logistics solutions and technical support to responding organisations. WFP also acts as a ‘provider of last resort’ offering common logistics services, when critical gaps hamper the humanitarian response.

UNSGM

By Stefan Kloth

The UN Secretary-General's Mechanism (UNSGM) for the Investigation of Alleged Use of Chemical and Biological Weapons provides the framework for an objective and scientific investigation of alleged violations of the Geneva Protocol or of other relevant rules of customary international law. At the request of any Member State, the Secretary-General (SG) is authorised to launch an investigation, dispatch a fact-finding team and report to all UN Member States. As a key part of the mechanism, the SG maintains a roster of experts and laboratories provided by Member States, as well as guidelines and procedures for conducting investigations. So far, investigations under the current guidelines have taken place in Mozambique (1992), Azerbaijan (1992) and Syria (2013).

In the event of a suspected use of chemical weapons, as in the case of Syria, the SG relies on the internationally accredited laboratories of the Organisation for the Prohibition of Chemical Weapons (OPCW). However, there is no equivalent organisation for the prohibition of biological weapons, so the lab analyses of a UN mission investigating the alleged use of biological weapons may be questioned or rejected.

If a UN Member State suspects the use of biological weapons, the UNSGM is activated and calls together a team of

individual experts from the roster to begin the pre-mission phase. The team collects information about the current security, political and health situation, the background of the alleged attack, regional studies, necessary equipment and professional experts. Then they travel to the affected region and start the fact-finding mission, collecting samples, conducting their investigation and interviewing potential victims and witnesses. Following this, the team issues a report analysing whether the observed disease outbreak was of natural origin or initiated deliberately.

The right training is vital to prepare experts for a potential mission. The UN Office for Disarmament Affairs (UNODA) coordinates training with Member States – for example, with Sweden in 2009 and France in 2012. In 2013, Denmark proposed the use of functional subunits, teams of two to five experts, to contribute specific functions and skills to UNSGM-sanctioned investigations.

On behalf of the German Federal Foreign Office, the Robert Koch Institute (RKI) organises field exercises to train teams to investigate the alleged use of biological weapons. RKI also works with UNODA to organise workshops on identifying bacteria, viruses and toxins as biological agents. Given that experts on mission may be exposed to the risk of armed conflict, terrorism, kidnapping or even assassination attempts, they are strongly encouraged to participate in HEAT courses (hostile environment awareness training) to prepare them both physically and psychologically for their deployment.

International Red Cross and Red Crescent Movement

By Franziska Kellerhaus

The International Red Cross and Red Crescent Movement is the world's largest humanitarian network. It is made up of three independent components, namely the International Committee of the Red Cross (ICRC), the International Federation of Red Cross and Red Crescent Societies (IFRC) and 192 National Red Cross and Red Crescent Societies around the world. Together, the Movement counts a total of nearly 100 million members, volunteers and supporters. The Movement's work is guided by its seven fundamental principles: Humanity, Impartiality, Neutrality, Independence, Voluntary Service, Unity and Universality.

International Committee of the Red Cross (ICRC)

The ICRC's exclusively humanitarian mission is to protect the lives and dignity of victims of war and internal violence and to provide them with assistance. The ICRC seeks to ensure that people affected by conflict have access to basic healthcare services that meet universally recognised standards. This may involve supporting existing health services or temporarily replacing them. During situations of conflict, the ICRC is responsible for directing and coordinating the

Movement's international relief activities. It promotes the importance of international humanitarian law (IHL), including the protection of humanitarian and medical personnel and facilities. As the custodian of the Geneva Conventions, the ICRC has a permanent mandate under international law to visit places of detention, reunite separated families and undertake other humanitarian activities during armed conflicts. The ICRC works to raise public awareness of the dangers of mines and explosive remnants of war and traces people who have gone missing during conflicts.

International Federation of Red Cross and Red Crescent Societies (IFRC)

The IFRC coordinates and directs international assistance following natural and man-made disasters in non-conflict situations, in cooperation with National Red Cross and Red Crescent Societies. The IFRC's relief operations are combined with development work, including disaster preparedness programmes, health and care activities, and the promotion of humanitarian values. Health and care activities include first aid and emergency response, as well as epidemic control, programmes in health promotion and prevention, addressing stigma, providing psychosocial care, and enabling community empowerment. Around the world, hundreds of thousands of the Movement's volunteers work in communities to promote health and prevent disease.

National Red Cross and Red Crescent Societies

The 192 National Red Cross and Red Crescent Societies are neither governmental institutions nor wholly separate non-governmental organisations. Their relationship to the authorities is defined as ‘auxiliary’, wherein the National Society takes on certain tasks which arise from the Geneva Conventions and its additional protocols. Through the de-centralised structure of National Societies (NSs), with their branches at regional and local levels and their networks of volunteers, the Movement is present in communities before, during and after disasters and health emergencies. This provides a unique opportunity for fast emergency response as well as long-term community engagement.

The German Red Cross (GRC) is one of the 192 National Societies. In addition to its national-level tasks, the GRC assists other NSs in around 50 countries, both in acute emergencies and in long-term support to strengthen the resilience of communities. This includes support for primary and pre-hospital care, outbreak preparedness and response, treatment of non-communicable diseases and psychosocial support.

Emergency response mechanisms

Emergency Response Units (ERUs) form a vital part of the disaster response system employed by the Movement

under the coordination of the IFRC. ERUs were first created in 1994 to give immediate support to National Red Cross and Red Crescent Societies in disaster-affected countries. They provide specific support or direct services when local facilities are damaged, destroyed, overwhelmed or unable to cope with the existing need.

An ERU is a team of trained technical specialists, ready to be deployed at short notice, which uses pre-packed sets of standardised equipment. Different types of ERUs include: Emergency Clinic, Emergency Hospital, WASH, Logistics, Relief, and IT & Telecommunication. ERUs are designed to be self-sufficient for one month and can operate for up to four months.

ERUs are deployed solely upon request of the affected Red Cross or Red Crescent National Society, under the coordination of IFRC and in accordance with the fundamental principles of the Movement. The need for assistance may continue beyond an ERU's four-month operational period. If so, the service can be managed by the IFRC's ongoing operation, the host National Society, the local government or other organisations.

In addition to Health ERUs, which provide much needed clinical care, the IFRC and National Societies are working on the development of Public Health ERUs. These will complement curative services with public health-focused tools to mitigate health risks at the community level. This is based on the understanding that epidemics start and

end in communities, and that community-driven efforts are needed to prevent, detect and respond to infectious disease threats.

The GRC maintains Health and WASH ERUs, with trained technical personnel on standby and pre-packed equipment stored at Berlin airport, allowing the ERUs to be operational within 72 hours. The GRC also maintains a curative mobile facility for the treatment of highly-infectious diseases, to complement the public health-focused ERU modules.

Examples of Health ERUs

The Emergency Clinic ERU provides immediate basic, curative, preventive and community health care for up to 30,000 beneficiaries, using a modular approach adjusting to local needs. The unit deploys with the inter-agency emergency health kit. The ERU can deliver basic outpatient clinic services, maternal-child health (including uncomplicated deliveries), community health outreach, immunisation and nutritional surveillance. It does not function as a hospital but has a 10-20 overnight bed-capacity for observation only.

The Emergency Hospital ERU functions as a secondary-level field hospital, providing referral-level multi-disciplinary care to a population of up to 250,000 people. It can be enhanced to a tertiary-level hospital if needed. The inpatient capacity ranges from 75-150 beds, providing surgery, limited

traumatology, anaesthesia, internal medicine gynaecology, obstetrics and paediatrics. It consists of one or two operating theatres, a delivery room, inpatient wards and treatment areas, x-ray and a laboratory. It also provides an outpatient department and an emergency room to ensure the treatment of casualties as a referral facility. It is designed in a modular way to be adaptable to a given situation in the field and to best integrate into the existing local health system and structures.

Another important element of the Movement's disaster response system is the 'surge' capacity provided by the Rapid Response Mechanism (RRM) of the IFRC and the Rapid Deployment Mechanism (RDM) of the ICRC. Members of the RRM and RDM surge rosters are experienced disaster managers and technical experts who support emergency response operations led by National Societies, the IFRC or the ICRC by assessing needs and coordinating or supporting the implementation of immediate response efforts. Rapid response personnel will have technical expertise in relief, health, nutrition, public health and epidemiology, psychological support, water and sanitation, shelter, logistics, as well as finance and administration. They can be deployed anywhere in the world within 24 hours, for a period of up to six months.

The recruitment, selection, performance management and development of surge personnel across the Movement is

informed by a competency-based approach, which aims to deploy staff with the most relevant skills for a particular mission. This approach facilitates equal access to surge rosters, independent of nationality and based solely on the skills and competencies of the responders. Surge tools formerly known as FACT (Field Assessment Coordination Teams) and RDRT (Regional Disaster Response Teams) have been merged into this new approach.

World Bank

In July 1944, the World Bank was founded under the Bretton Woods Agreement to aid the economic advancement of developing nations by providing financing, advice and research. Today the World Bank, headquartered in Washington D.C., has expanded from a single institution to a group of five cooperative institutional organisations, called the World Bank Group. The World Bank's primary goal is to end extreme poverty by decreasing the number of people living on less than \$1.90 a day to below 3% of the world population, by 2030. Its second goal is to enhance overall prosperity by increasing income growth in the bottom 40% of every country in the world. The Bank gives out low-interest loans, zero-interest credits and grants to qualifying governments, to support the development of individual economies. This in turn helps in the development of global education, healthcare, public administration, infrastructure and private-sector development.

Pandemic Emergency Financing Facility

The Pandemic Emergency Financing Facility (PEF) was established in 2016, to support the world's poorest countries with extra financing when they face a pandemic outbreak. PEF, which is housed at the World Bank, is financed through funding from Australia, Germany, the International Development Association (IDA) and Japan, as well as through insurance coverage and insurance-linked swaps arranged by the World Bank. To qualify for PEF financing, countries must be members of the IDA. The funds are provided as grants and do not need to be repaid. PEF operations are overseen by a steering body composed of donors (Australia, Germany, Japan), international organisations (including WHO, UNICEF and the World Bank), and two IDA-eligible countries (currently Haiti and Liberia). Voting members of this body are Australia, Germany and Japan; WHO and the World Bank are non-voting members. Event eligibility notices initiate the formal monitoring of an outbreak to determine its potential eligibility for payment from the insurance window. Notices were issued in the case of the 2018 Lassa fever outbreak in Nigeria, the 10th Ebola outbreak in the Democratic Republic of Congo, and COVID-19.

Regional organisations

African Union (AU)

The African Union (AU) is an organisation consisting of 55 African states with a secretariat (African Union Commission) based in Addis Ababa, Ethiopia. The AU was established on 9 July 2002 in Durban, South Africa, as a successor to the Organisation of African Unity (OAU).

The AU seeks to promote development, combat poverty and maintain peace and security in Africa. It supports the public health initiatives of member states through the Africa Centres for Disease Control and Prevention (see below).

AU regional economic communities

Eight regional economic communities are recognised as the building blocks of the African Union, namely:

- Arab Maghreb Union (AMU)
- Community of Sahel-Saharan states (CEN-SAD)
- Common market for Eastern and Southern Africa (COMESA)
- East African Community (EAC)
- Economic Community of Central African States (ECCAS)

- Economic Community of West African States (ECOWAS)
- Intergovernmental Authority on Development (IGAD)
- Southern African Development Community (SADC)

West African Health Organization (WAHO)

A number of the regional economic communities have specialised institutes for health. ECOWAS, for example, established the West African Health Organization (WAHO) in 1987, whose mission is ‘the attainment of the highest possible standard and protection of health of the peoples in the sub-region through the harmonisation of the policies of the member states, pooling of resources, and cooperation with one another and with others for a collective and strategic combat against the health problems of the sub-region’. As a politically mandated institute, the activities of WAHO include research into the major endemic diseases in the region, the training of medical and paramedical specialists, harmonising regional laboratories and building institutional capacity.

Africa CDC

The Africa Centres for Disease Control and Prevention, also referred to as Africa CDC, is a specialised technical institution of the African Union established to support public health initiatives of member states and strengthen the

capacity of their health institutions to detect, prevent, control and respond quickly and effectively to disease threats.

Established in January 2016, Africa CDC supports African Union member states in providing coordinated and integrated solutions to the inadequacies in their public health infrastructure, human resource capacity, disease surveillance, laboratory diagnostics, and preparedness and response to health emergencies and disasters.

Administratively, Africa CDC operates a decentralised model that works with national public health institutes of member states through five regional collaborating centres located in Egypt for Northern Africa, Gabon for Central Africa, Kenya for Eastern Africa, Nigeria for Western Africa and Zambia for the Southern Africa region.

In 2019, the Africa CDC and WHO signed an agreement to operationalise their relationship and outline mechanisms for collaboration. The action plan identifies key areas including emergency preparedness and response, and health security in the overall context of health-systems strengthening. A joint task force with five technical working groups was established to guide the efforts in the areas of partnerships and resource mobilisation, monitoring progress in implementing international health regulations, public health emergency preparedness and response, strengthening surveillance and laboratory capacities, and antimicrobial resistance.

Asia-Pacific Economic Cooperation (APEC)

The Asia-Pacific Economic Cooperation (APEC) is a regional economic forum established in 1989. APEC's 21 members aim to create greater prosperity for the people of the region by promoting balanced, inclusive, sustainable, innovative and secure growth and by accelerating regional economic integration.

Within APEC is an Emergency Preparedness Working Group (EPWG), mandated to coordinate and facilitate emergency and disaster preparedness. EPWG is focused on reducing the risk of disasters, and building business and community resilience through knowledge sharing and collaboration.

Association of Southeast Asian Nations (ASEAN)

Established in 1967, the Association of Southeast Asian Nations (ASEAN) is an intergovernmental organisation that promotes economic, political and security cooperation among its 10 Southeast Asian country members: Brunei, Cambodia, Indonesia, Laos, Malaysia, Myanmar, the Philippines, Singapore, Thailand and Vietnam.

In 2003, ASEAN established the ASEAN Committee on Disaster Management (ACDM), which is responsible for coordinating and implementing regional disaster management activities for member states. It consists of the heads of national disaster management offices (NDMOs) of all ASEAN member countries. As part of its objective to build disaster-resilient countries and safer communities, it adopted the ASEAN Agreement on Disaster Management and Emergency (AADMER) in 2005. The AADMER sets in place regional policies and operational and logistical mechanisms to enable ASEAN member states to seek and extend assistance in times of disaster and collaborate in disaster mitigation, prevention, preparedness, response, recovery and rehabilitation.

Coordination takes place through the ASEAN Coordinating Centre for Humanitarian Assistance on disaster management (AHA Centre), which also facilitates cooperation with the UN and international organisations in disaster management in the region. In addition to disaster monitoring and preparedness and response, the AHA Centre conducts capacity building, stockpiles relief items and coordinates the ASEAN Emergency Response and Assessment Team (ERAT).

Caribbean Disaster Emergency Management Agency (CDEMA)

CDEMA is a regional inter-governmental agency for disaster management in the Caribbean Community (CARICOM). Established in 1991, it adopts a comprehensive approach to disaster management that seeks to reduce the risk and loss associated with natural and technological hazards and the effects of climate change to enhance regional sustainable development. CDEMA presently comprises 18 participating states.

Central American Integration System (SICA)

In 1992, the Central American Integration System (SICA) was formed, with the goal of promoting peace, freedom, democracy and development among Central American states, based on the respect, protection and promotion of human rights. SICA is the institutional framework for Central American regional integration, created by Costa Rica, El Salvador, Guatemala, Honduras, Nicaragua and Panama. In 2000, Belize joined, followed by the Dominican Republic in 2013.

In 1995, the presidents of Central American states completed the adoption of the Treaty of Social Integration of Central America (TISCA). Under TISCA, a new governing

body for regional health was formed, known as the Council of Ministers of Health of Central America (COMISCA). COMISCA's role is to identify and prioritize regional health problems and to frame strategies to guide the response to those health needs. Over the past two decades, COMISCA has played a prominent role in the region, not least in enhancing the integration of Central American peoples.

Since 2007, the executive secretariat of COMISCA has been based in San Salvador, El Salvador. COMISCA meetings – which are hosted by each member country in turn – constitute the main regional forum for the analysis, deliberation and proposals of regional ministers of health. The PAHO / WHO representative in the host country attends in an observer's capacity, along with advisors from country delegations and specialist contributors.

European Union (EU)

Ever since it was founded in the 1950s, the European Community and its successor, the European Union (EU), have been engaged in crisis management, development cooperation and humanitarian aid. What began as an economic union has evolved into an organisation spanning policy areas from climate, environment and health to external relations, security, justice and migration. At the core of the EU are the citizens of its 27 Member States that belong to the EU. Although the Member States all remain sovereign and independent states, they have decided to pool some of

their sovereignty in areas where collaboration makes sense. Member States delegate some of their decision-making powers to the shared institutions they have created, so that decisions on specific matters of common interest can be made democratically at EU level.

Global health architecture of the European Union

By Susan Bergner

This section outlines the latest developments in the EU's global health landscape and presents the most relevant frameworks, actors and instruments.

Participation of the EU in global health issues incorporates both external health-related policies, such as health in development, and the EU's relations with the World Health Organization. In addition, health policies within the EU determine the Union's ability to act as a partner on the international scene.

Legal aspects of the EU's global health policies

The EU's scope of action in global health policies is based on two narratives: health protection and the right to health. Although EU competences in health are limited to a coordinating and complementing role in Europe (Treaty on the Functioning of the European Union (TFEU), Article 168), the EU Charter of Fundamental Rights (CFR) states that everyone has the right to access health care, (CFR, Article

35), making it a European value. Article 3 of the Treaty on the European Union states that the Union shall uphold and promote its values internationally, including the protection of human rights, which would incorporate the right to health. Aside from this rights-based rationale, the EU has a mission to foster international cooperation in public health (TFEU, Article 168 (3)). A special focus has been put on health protection since the EU 'Decision on serious cross-border threats to health' opted for more European and internationally coordinated approaches during health crises. The COVID-19 pandemic triggered active discussions about the enlargement of EU competences in health crises.

Global health in the EU's strategic documents

The EU has developed a strategic outline for its role in global health policies in its Council Conclusions from 2010. The conclusions state three key objectives: the improvement of health, the reduction of inequalities and protection against global health risks. These should be achieved through an 'Equity and Health in All Policies' approach. In broader strategic documents such as the 'Global Strategy for the European Union's Foreign and Security Policy', health is briefly mentioned in response to global pandemics.

Key EU global health actors

There is a wide range of global health actors within the EU's institutional landscape, including the directorates of

the Commission but also some EU agencies. With regards to health in development and humanitarian policies, the Directorates-General for International Cooperation and Development (DG DEVCO) and European Civil Protection and Humanitarian Aid Operations (DG ECHO) are relevant, as is the European Centre for Disease Control and Outbreak (ECDC). Regarding pharmaceuticals, the Directorates-General for Health and Food Safety (DG SANTE) and Trade (DG TRADE), the European Medicines Agency (EMA) and parts of the Service for Foreign Policy Instruments (FPI) are relevant. The Joint Research Centre (JRC) and the Directorate-General for Research and Innovation (DG RTD) focus on research into disease control. During the COVID-19 pandemic, the European External Action Service (EEAS), the European Council and the European Parliament became more engaged with global health topics.

Major global health instruments of the EU

The EU's major instrument in international crisis management is the EU Civil Protection Mechanism (EUCPM). This can be activated by any country or international organisation asking for assistance and can provide equipment or human resources in Europe and beyond. For global health, this might mean the distribution of medical equipment or the deployment of medical teams abroad – with the European Medical Corps. The corps was created after the West Africa Ebola experience, to deploy expert teams to health crises quickly from states inside and outside Europe.

A clear drawback of this mechanism is its dependence on EU member states to provide the necessary supplies and experts. In response to that, the Commission established a medical stockpile serving as a common European reserve under the EUCPM during COVID-19.

Health has been an important element in the EU's development policy. At the time of writing, the new Neighbourhood, Development and International Cooperation Instrument was being negotiated. Health is primarily located within the geographic and thematic pillar of the instrument. In response to the COVID-19 pandemic, a new health programme for Europe (EU4Health) was developed that can also be used to advance global health initiatives.

Changes in the EU's global health architecture induced by the pandemic led to new instruments (EU4Health, medical stockpiles) and new actors in the field (EEAS), but the foundation for the EU's scope of action in global health was laid earlier. The future will show whether current debates on extending the EU's legal competences or updating the strategic framework will be translated into action.

European Centre for Disease Prevention and Control

By Christian Winter

The European Centre for Disease Prevention and Control (ECDC) is an EU agency aimed at strengthening Europe's defences against infectious diseases. Through its networks

of Member State experts, ECDC has the capacity to mobilise EU expertise in field epidemiology and other areas of field response.

European Public Health Teams (PHTs) are one of the main components of the European Medical Corps. PHTs consist of experts in prevention and control of communicable diseases, ready to support activities in affected countries. The PHTs must be ready to deploy rapidly to assess public health risks and needs related to a health emergency, or to support response operations. PHTs are assembled ad hoc with public health experts from participating countries and ECDC. These teams can therefore serve to support World Health Organization (WHO) rapid response teams dealing with public health events such as infectious disease outbreaks.

The mechanism to deploy PHTs follows the approach of the EU Civil Protection Mechanism (EUCPM). It gives the European Commission and ECDC the role of shaping the mission and including competent public health bodies from participating countries in the planning of the mission. The mechanism is activated by a request for assistance by an EU country, a third country or a United Nations (UN) agency. Whether or not the request for assistance comes from WHO, communication and coordination with WHO starts immediately.

ECDC and the Commission clarify the terms of reference for the PHT mission. ECDC defines the expert profiles

needed (e.g. clinical, epidemiological and microbiological expertise, language skills, knowledge of the mission setting), on the basis of which a request for experts for the mission is circulated throughout European networks. Participating countries propose experts for the mission, which are reviewed and shortlisted by ECDC. The Commission accepts and confirms the list of experts and proposes them to the requesting authority. For joint UN-EU missions, WHO may be involved in the process of expert selection. The European PHT is then deployed with the Emergency Response Coordination Centre (ERCC) of DG ECHO covering the logistical and financial needs of the mission. ECDC provides technical and scientific leadership during the mission preparations and the mission itself.

Pacific Islands Forum (PIF)

Founded in 1971, the Pacific Islands Forum (PIF) is an inter-governmental organisation that aims to enhance the economic and social well-being of the people of the South Pacific by fostering cooperation between countries and territories of the Pacific Ocean, including the formation of a trade bloc and regional peacekeeping operations. Headquartered in Suva, Fiji, the PIF comprises 18 members. PIF is a UN General Assembly observer.

Shanghai Cooperation Organisation (SCO)

The Shanghai Cooperation Organisation, also known as the Shanghai Pact, was established in Shanghai in 2001 as a multilateral association to ensure security and maintain stability across the Eurasian region, join forces to counteract emerging challenges and threats, and enhance trade, as well as cultural and humanitarian cooperation. The SCO has eight member countries: China, Kazakhstan, Kyrgyzstan, Russia, Tajikistan, Uzbekistan, India and Pakistan. The SCO is the largest regional organisation in the world in terms of geographical coverage and population. The SCO has been an observer at the UN General Assembly since 2005.

South Asian Association for Regional Cooperation (SAARC)

The South Asian Association for Regional Cooperation (SAARC) is the regional intergovernmental organisation and geopolitical union of states in South Asia, established in 1985 in Dhaka, Bangladesh. Its member states are Afghanistan, Bangladesh, Bhutan, India, the Maldives, Nepal, Pakistan and Sri Lanka. The SAARC maintains permanent diplomatic relations at the UN as an observer.

In 2006, the organisation adopted the SAARC Comprehensive Framework on Disaster Management, establishing the SAARC Disaster Management Centre (SDMC), whose mandate is to establish and strengthen the region's disaster management system to reduce risks and improve response and recovery. SDMC is located at the SAARC secretariat in New Delhi. In 2016, SDMC merged with other regional centres, including SAARC's Meteorological Research Centre in Bangladesh, SAARC's Forestry Centre in Bhutan and SAARC's Coastal Zone Management Centre in the Maldives.

National-level health systems

Health systems and public health institutions

By Anne Bergh

Countries organise their health system in many ways, involving both public and private sectors. Well-functioning health systems promote health, deliver preventive and curative services, and enable countries to respond in times of health crises. WHO has defined six core components, or building blocks, that describe effective health systems:

- Service delivery
- Health workforce
- Health information systems
- Access to essential medicines
- Financing
- Leadership and governance

The extent to which people can access health services and how far these services are covered by health insurance varies from country to country. Universal health coverage is one of the targets of the UN's Sustainable Development Goals (SDGs), but it requires funding and systems that make health services affordable to all. According to WHO, health spending is on the rise globally and health system

resources are increasingly coming from pooled funding rather than out-of-pocket spending. Aid or external funding accounts for less than 1% of global health expenditure, but it is still a large and rising source of funding for health systems in low-income countries. The USA, Germany, United Kingdom, Japan and EU institutions were the top five aid donors measured in US dollar contributions by the OECD Development Assistance Committee in 2019. All five donors engage in global health assistance and public health collaboration.

National Public Health Institutes (NPHIs) are key institutions in a health system. There are also regional public health agencies, for example the European Centre for Disease Prevention and Control (ECDC) and the Africa Centre for Disease Control and Prevention (Africa CDC). At the global level, the International Association of Public Health Institutes (IANPHI) brings together 114 member institutes from 99 countries.

NPHIs are diverse in size and scope. They are often subordinate to their health authorities or set up as semi-independent entities. According to IANPHI, ‘a national public health institute (NPHI) is a government agency, or closely networked group of agencies, that provides science-based leadership, expertise, and coordination for a country’s public health activities.’ NPHIs deliver on public health core functions, defined by IANPHI as follows:

- Evaluation and analysis of health status;

- Public health surveillance, problem investigation and control of risks and threats to public health;
- Prevention programmes and health promotion;
- Social participation in health;
- Planning and management;
- Regulation and enforcement;
- Evaluation and promotion of equitable access to necessary health services;
- Human resource development and training;
- Quality assurance in personal and population-based health services;
- Public health research;
- Reduction of the impact of emergencies and disasters on health.

To deliver on these public health core functions, many NPHIs engage in global health and collaborate with sister institutions, WHO and the wider network of global health actors and organisations. The three leading donors of development assistance all have NPHIs that engage in global collaboration:

- The US Centers for Disease Control and Prevention (CDC)
- The Robert Koch Institute, Germany
- Public Health England/National Institute for Health Protection

There is more information on these three NPHIs below. A list of all NPHIs that are members of IANPHI is available at the IANPHI website: www.ianphi.org

US Centers for Disease Control and Prevention (CDC)

The CDC is the health protection agency for the US, falling under the federal government's Department of Health and Human Services. Founded in 1946 and based in Atlanta, Georgia, its role is to detect and respond to new and emerging health threats; to tackle the health problems causing greatest death and disability for Americans; to prevent disease through science and advanced technology; to promote healthy and safe behaviours and communities; and to train public health workers and leaders.

CDC works in over 60 countries across the world, supporting public health institutions from Latin America to Africa, the Middle East and Asia. In 2020, CDC celebrated 40 years of its Field Epidemiology Training Program (FETP) which has trained more than 18,000 public health professionals to fight infectious diseases, public health emergencies and chronic diseases in 80 countries. CDC has global divisions in HIV and TB, parasitic diseases and malaria, global health protection, and global immunisation.

Robert Koch Institute (RKI)

Since its founding in 1891, the Robert Koch Institute has been dedicated to the investigation and prevention of diseases. It is the German government's central scientific institution in the field of biomedicine and one of the most important bodies for the safeguarding of public health in Germany. The institute is responsible for nationwide health monitoring and collects and interprets epidemiological data communicated to the institute as a result of the German Protection against Infection Act. Its scientists conduct research in infectious disease epidemiology as well as sentinel surveillance projects and support the federal states in outbreak investigations. Since national and international health protection is closely linked, a Centre for International Health Protection (ZIG) was set up in 2019 to strengthen health sustainably in international contexts. The RKI hosts the WHO Collaborating Centre for Emerging Infections and Biological Threats, the WHO Collaborating Centre for Global Outbreak Alert and Response (GOARN), the EMT national focal point, and the STAKOB HQ (see below).

STAKOB – Competence and treatment centres for high consequence infectious diseases

By Bettina Ruehe, René Gottschalk and Timo Wolf

The STAKOB network brings together experts in public health preparedness and response, and in the clinical management of patients with high consequence infectious

diseases (HCIDs). Headquartered at the RKI, STAKOB has seven treatment centres across Germany to ensure rapid access for patients with HCIDs (e.g. viral haemorrhagic fevers, pneumonic plague). The centres offer high-level isolation units which meet the most stringent standards of patient care and isolation, training of personnel and laboratory diagnostics.

The treatment of patients with HCIDs requires great expertise in infectious diseases and intensive care, particularly under the challenging conditions of a high-level isolation environment. Medical staff are provided extensive training in the use of personal protective equipment and the technical procedures and skills required to reduce the high risk of infection. In addition to treating patients with HCIDs, the centres provide advice for health authorities, coordinate anti-epidemic measures (e.g. contact management, post-exposure prophylaxis) and compile up-to-date epidemiological information to inform the appropriate state healthcare authorities.

The well-established, close collaboration between clinical and public health experts has proved to be a unique and indispensable feature of the STAKOB network, ensuring the highest standards in the management of HCIDs. The STAKOB network collaborates closely with the German Federal Foreign Office, particularly regarding international medical evacuations to Germany – including specialised care in a high-level isolation unit for international UN or NGO staff who may require it.

Public Health England / National Institute for Health Protection

Public Health England (PHE) – which employed 5,500 full-time staff in health protection and prevention – had a strong engagement in global health, health security and outbreak emergency response. PHE worked with international partners to strengthen public health systems in partner countries and regions, and shared information and evidence on best practice for emergency preparedness, resilience and response functions.

In August 2020, during the COVID-19 pandemic, the UK government announced it would abolish PHE and replace it with a new agency whose main focus would be to prepare for and respond to external health threats, such as pandemics. The new agency would merge PHE with the National Health Service's Test and Trace service and the Joint Biosecurity Centre to form the National Institute for Health Protection, under a single leadership team.

Armed forces medical services

By Samuel T. Boland

All militaries have some kind of medical service in order to maintain the health of their armed forces and to treat wounded soldiers. Military medical resources include medical personnel, medicine, equipment and hospitals, as well as

peripheral infrastructure such as ambulances and medical supply chains.

While some militaries limit the provision of medical services to their own personnel, many extend medical services to civilians. This is particularly true in times of peace, when military medical personnel require day-to-day practice to ensure military readiness. Sometimes this is done by militaries to convey a positive image to a population and to win their ‘hearts and minds’ (in other words, to garner favour).

While in some contexts, military forces and their associated medical services are or are perceived to be belligerents, in others they are not. Therefore, during humanitarian or public health emergency response, military medical services will often respond alongside civilian responders, and the degree to which this may be controversial is highly contextual. During rapid-onset disasters, they may even be first responders due to their rapid response capabilities. At other times, military medical services may not directly engage and support affected civilian populations, but may contribute resources to civilian responders. Military resources for humanitarian or public health purposes can be requested by the UN Humanitarian Coordinator and are often negotiated through the UN Office for the Coordination of Humanitarian Affairs (OCHA).

OCHA maintains a set of guiding documents regarding acceptable civil-military cooperation, including Guidelines on the Use of Military and Civil Defence Assets to Sup-

port United Nations Humanitarian Activities in Complex Emergencies (the MCDA Guidelines) and Guidelines on the Use of Foreign Military and Civil Defence Assets in Disaster Relief (the Oslo Guidelines).

Militaries are also beholden to the Geneva Convention IV which requires them to support the provision of medicine and ‘maintain hospitals and public health and hygiene’ when other actors are not capable or available to do so.

Global partnerships, philanthropists, NGOs and non-state actors

Global partnerships

Global health partnerships were established to streamline efforts in the health sector and respond to the challenges posed by the aid environment. They involve governments, civil society, international organisations, the private sector and affected communities under an umbrella framework. Their goal is to achieve health improvement that no organisation could achieve alone. CEPI; the Global Fund to Fight AIDS, Tuberculosis and Malaria; and GAVI, The Vaccine Alliance, are three prominent examples of global health partnerships. This section also covers major private foundations, international NGOs and other non-state actors.

The Coalition for Epidemic Preparedness Innovations (CEPI)

CEPI is a partnership between public, private, philanthropic and civil organisations, launched at the World Economic Forum's Annual Meeting in Davos in 2017, to develop vaccines to stop future epidemics. In response to COVID-19, CEPI initiated nine partnerships to develop vaccines against the novel coronavirus. The programmes leveraged rapid

response platforms already supported by CEPI as well as new partnerships.

CEPI's other priority diseases include Ebola virus, Lassa virus, Middle East Respiratory Syndrome coronavirus, Nipah virus, Rift Valley Fever and Chikungunya virus. CEPI has invested in platform technologies that can be used for rapid vaccine and immunoprophylactic development against unknown pathogens (Disease X).

Gavi, the Vaccine Alliance

Gavi, the Vaccine Alliance, is a public-private partnership that helps vaccinate children across the world against infectious diseases. Founded in 2000, Gavi has helped to immunise over 760 million children, preventing an estimated 13 million deaths and helping to halve child mortality in 73 developing countries. Gavi plays a key role in improving global health security by supporting health systems as well as funding global stockpiles for Ebola, cholera, meningitis and yellow fever vaccines. Gavi employs innovative technology, including drones and biometrics, in its work. The alliance brings together developing country and donor governments, WHO, UNICEF, the World Bank, the vaccine industry, technical agencies, civil society, the Bill & Melinda Gates Foundation and other private sector partners.

The Global Fund to Fight AIDS, Tuberculosis and Malaria (GFATM)

Established in 2002, the Global Fund to Fight AIDS, Tuberculosis and Malaria (GFATM), also known as the Global Fund, is an international financing and partnership organisation that aims to ‘attract, leverage and invest additional resources to end the epidemics of HIV/AIDS, tuberculosis and malaria to support attainment of the Sustainable Development Goals established by the United Nations’. Based in Geneva, Switzerland, the Global Fund is currently the largest financier of AIDS, TB, and malaria prevention, treatment, and care programmes. Unlike the implementing agencies that partner with the Global Fund, the Global Fund itself is a financing mechanism.

Philanthropists

Some prominent private, philanthropic foundations and trusts working in the field of emergency healthcare are outlined below.

CDC Foundation

By Samuel T. Boland

The CDC Foundation is a private non-profit organisation that was created by the United States Congress to establish collaborative projects between the Centers for Disease Control and Prevention (CDC) and philanthropists, private

entities and individuals. The organisation and its employees are not part of the US Government and it operates independently from the CDC.

At its core, the CDC Foundation helps the CDC to ‘pursue innovative ideas that might not be possible without the support of external partners.’ This support is usually limited to funding: the Foundation mobilises and consolidates funds from the philanthropic and private sectors (individuals, foundations, corporations, universities, NGOs and other organisations) and disperses them to the CDC for the latter’s domestic and international health protection work. While normally limited to funding, the Foundation’s support can also include expertise, information and/or introduction to relevant agencies and partners.

The independent operation of the CDC Foundation in support of the CDC allows consideration of riskier or smaller projects that would normally be outside the CDC’s purview. This can include new pilot projects, the expansion of existing CDC programmes, or the launch of new programmes. Innovative or urgent programmes can be funded without requiring direct funding or oversight by the US Congress.

Although the CDC Foundation is independent, its support is limited to projects that are aligned with the CDC’s mission and priorities, and those that maintain the CDC’s research independence. Projects must also have appropriate research methodologies and address conflicts of interest. In line with

these requirements, the Foundation issues requests for proposals to sub-grant funds received for specific projects.

As of August 2020, the CDC Foundation had launched approximately 1,000 health protection programmes across 140 countries and had raised approximately US\$ 900 million in support of the CDC.

UN Foundation

Founded in 1998 as an independent foundation to support the goals of the United Nations, the UN Foundation creates and supports public private partnerships and initiatives that work with the UN and partners, including businesses, to achieve impact at scale on the SDGs, climate change and other ‘major collective challenges’. The Foundation is governed by a board of directors and has partnerships with, among others, Disney, Stephen Curry, Walgreens Boots Alliance, BNY Mellon, Johnson & Johnson, Takeda, the Vodafone Foundation, the Bill & Melinda Gates Foundation, the Ariadne Getty Foundation, the Nike Foundation, Royal Dutch Shell, and the William & Flora Hewlett Foundation.

Wellcome Trust

The Wellcome Trust was founded from the legacy of the British medical entrepreneur, collector and philanthropist Sir Henry Wellcome, who died in 1936. Its goal is to ‘improve health by helping great ideas to thrive’. The charity

supports researchers to improve human and animal health and, in its own words, takes on big health challenges, campaigns for better science and helps everyone get involved with science and health research. The trust acts as an independent, global charitable foundation, regulated by the UK Charity Commission, with a board of governors to oversee and guide the trust's mission.

Bill & Melinda Gates Foundation

The Bill & Melinda Gates Foundation is an American private foundation established in 2000 to promote healthcare and reduce poverty worldwide. It focuses on controlling infectious diseases, promoting reproductive healthcare and family planning, and enhancing health policy and management. It has committed large amounts of funding to the GAVI Alliance, WHO, The Global Fund to Fight AIDS, Tuberculosis and Malaria, PATH, UNICEF and the Rotary Foundation, among others. Based in Seattle, Washington, the foundation is guided by Bill and Melinda Gates and Warren Buffett.

Non-Governmental Organisations (NGOs)

Hundreds, if not thousands, of non-governmental organisations (NGOs) actively provide medical services in humanitarian settings around the world. The Global Health Cluster alone has over 900 partners in 23 countries currently engaged in the delivery of humanitarian health responses. Listed below are some examples of larger emergency healthcare-focused NGOs that are active globally.

Médecins Sans Frontières (MSF)

Médecins Sans Frontières (MSF) is an international, independent medical humanitarian organisation. It provides medical assistance to people affected by conflict, epidemics, disasters or exclusion from healthcare. MSF teams are made up of health professionals, logisticians and administrative staff, most of them hired locally. MSF's actions are guided by medical ethics and the principles of impartiality, independence and neutrality. MSF works in more than 70 countries and provides medical humanitarian assistance to save lives and ease the suffering of people in crisis situations.

Médecins du Monde (MdM)

Médecins du Monde (MdM) was founded in 1980 by the French doctor and politician Bernard Kouchner and 14 other doctors. It is an international humanitarian organisation

focused on supporting vulnerable groups in crisis situations. Core to MDM is the belief that its aid workers should ‘bear witness’ to violations of human rights and international humanitarian law through documenting these violations and informing the public. MDM has five priority areas for its campaigns: working with victims of crises and conflicts, promoting sexual and reproductive health, harm reduction, fighting HIV, and caring for migrant and displaced populations. The organisation is headquartered in Paris, France and is active in roughly 64 countries worldwide. MDM is a non-profit organisation and politically and religiously independent.

AMREF

The independent African NGO AMREF pursues the goal to enable better, sustainable healthcare in Africa by strengthening local structures (‘African solutions for African challenges’). Founded in 1957 as the Flying Doctors Service by three men with the vision to improve medical healthcare in rural areas of East Africa, it is today one of the largest NGOs in Africa. Headquartered in Nairobi, Kenya, AMREF has transformed itself from a purely charitable health organisation into an educational institution focused on training local health workers. AMREF’s priorities until 2022 are: access to healthcare, training of health personnel, innovative learning concepts, cost savings in basic healthcare and strengthening the right to health. These goals are based on the UN’s Sustainable Development Goals (SDGs): No

Hunger (SDG 2), Health and well-being (SDG 3), Gender equality (SDG 5), Clean water and sanitary facilities (SDG 6), and Partnerships to achieve the goals (SDG 17).

International Medical Corps (IMC)

The International Medical Corps (IMC) is a non-profit, humanitarian aid organisation operating across the world. Founded in 1984 by Dr Robert Simon and a group of American physicians and nurses, it provides emergency medical and related services to those affected by conflict, disaster and disease. An key focus of its mission is to strengthen local healthcare systems, through healthcare training in communities and promoting self-reliance. IMC has no political or religious affiliation.

Armed non-state actors

By Samuel T. Boland

There is a wide array of groups encapsulated by the term ‘armed non-state actor’, also referred to as ‘non-state armed groups’ (NSAGs).

These range from organised, funded and highly structured terrorist groups with particular political goals and objectives, to militia and rebel groups seeking political change, to mercenary groups seeking financial gain, to loosely organised community-defence groups that intend to secure

the safety of their people when government security forces are insufficient or unavailable.

This wide array of groups is also reflected in the different degrees to which these groups are legitimised by governments. Some NSAGs hold established territorial control and may even represent the government in their area by collecting taxes and running some civil services. Some do not hold territory and actively seek to usurp a recognised government. Meanwhile, others may be either tacitly or actively supported by a recognised government in order to supplement government forces against a third party NSAG.

The diversity of these groups means there is little global guidance for when and how to engage with them; but the need to do so during humanitarian crises or public health emergencies does arise, especially when ensuring personal safety and access to populations in need.

If present in-country, the UN Department of Safety and Security (UNDSS) is a useful resource for understanding the local NSAG landscape, including which groups are operating in which areas, the degree to which they represent a threat, and the extent to which it is appropriate to engage them in order to negotiate access through or within their area of operation.



Chapter 2

Values and conventions to consider*

Health emergencies may differ significantly from one situation to the next and need tailor-made responses. When deployed in a crisis zone, you will be faced with many moral dilemmas and human rights issues. The international community has a variety of conventions, principles and frameworks at its disposal to help professional emergency workers address such situations. This chapter highlights just a few of the diverse ethical and legal issues you may face and some of the tools to help you respond.

* For full credits, references and further reading on the subjects covered in this Chapter, please refer to Credits & References Chapter 2 on p. 543

Ethics and morality

By Ole Döring and Barbara Buchberger

The terms ethics and morality are often used synonymously in everyday language. In philosophy, however, there is a clear terminological distinction: morality is understood as a social system of norms for correct human action with a claim to common validity. The study of ethics is the reason-guided examination of morals. Within the framework of ethics, moral judgments can be systematised, analysed and questioned.

An understanding of ethics helps orientate us. It helps us interpret the position of an individual or group regarding values and norms in a specific context, and it improves our ability to understand the right course of action in a foreign environment.

Working in health emergencies can present moral dilemmas, which an understanding of ethics can help solve. A dilemma refers to a decision between two different, incompatible options (A or B). In a positive dilemma, either option leads to an agreeable outcome, such as two exits from a maze. In a negative dilemma, you have to choose between two options both of which have undesired consequences – the proverbial situation of being ‘stuck between a rock and a hard place.’

When faced with a dilemma, the first challenge is to identify what it is about. The decision on what to do can fall into one of the following categories:

- Moral questions – about the meaning of a concept, correct behaviour, norms or values ('Should I? Do I have to?')
- Legal questions – about rules, laws and knowledge ('May I? Am I allowed to?')
- Psychological questions – about explanations ('What does it mean to me?')
- Empathic-consultative questions – about help and feelings ('How are you?')
- Practical questions – about technical feasibility or organisation ('How?')

An acute example of a negative dilemma is the triage situation, where resources are too scarce to allow genuine moral action. In such tragic circumstances, that force decisions about life and death, ethics can assist in determining what is the 'right thing to do'.

In order to grasp the full extent of the consequences of choosing A or B, you should analyse both options to understand the potential risks and benefits of each. A closer look may reveal that a third possibility exists or that there is no dilemma at all; for example, your assumptions regarding the case may be wrong or you may have misunderstood the language or custom. So it is important to analyse every

possible alternative course of action, especially those that at first glance may appear unlikely. Unconventional or disruptive ideas may inspire a new direction or a change of perspective.

Ethics in health emergencies

By Jimmy Whitworth

Epidemics, emergencies and disasters can raise many ethical issues for the people involved whether they are responders, public health specialists or policy-makers. Such situations are often unfamiliar, stressful and upsetting, but the ethical issues that arise, while they may be more intense, are the same as those encountered in other settings. So, it is important to recognise that the principles and values embodied in international and national ethics guidelines, as well as human rights instruments, must be upheld in the provision of humanitarian assistance during emergencies. This means that surveillance and patient care during emergencies may need ethical oversight to address any conflicts that arise, including: access to care, standards of care, confidentiality, the duty to care, fairness, informed consent, liberty, moral relativism and privacy.

Emergency health workers have a primary obligation to do good work and to advance development, but not at the expense of increasing risk or doing harm. We must consider what we can contribute, while doing the right thing, as our

actions are not value-free. There is no universal ethical framework applicable to all situations, as ethical codes cannot legislate effectively for all eventualities. Therefore, what is needed is a professional commitment to ethical practice based on an understanding of the potential dilemmas involved. Being ethical is about being good, right, virtuous and embodying this in character, behaviour and action.

Medical ethics is based on four basic principles, which are also applicable beyond the medical setting:

- **Autonomy:** the obligation to respect the decision-making capacity of those that we seek to serve and to help (even if they do not wish to follow what you advise);
- **Beneficence:** the obligation to provide benefit and to maximise those benefits in the circumstances for the individual concerned;
- **Non-maleficence:** the obligation to avoid causing harm;
- **Justice:** the obligation of fairness in the distribution of benefits and risks across the population being served.

Ethical dilemmas occur when we have to choose between two or more unfavourable alternatives, where there is no perfect solution. By its definition, an ethical dilemma cannot readily be resolved in the sense that a resolution of the problem implies that there is a satisfactory answer to the problem. In reality the answer to an ethical dilemma is often the lesser of two evils. It is questionable to assume that there will always be an acceptable answer – it is more

a question of whether or not you can arrive at an outcome you can live with.

Take this example: a crowded ferry is holed below the waterline and more than 30 survivors are crowded into a lifeboat intended to hold seven. As night falls and a storm threatens, it becomes obvious that the lifeboat will have to be lightened if anyone is to survive. What should the captain do? Is the right thing to force some individuals to go over the side and drown, so that the rest in the lifeboat have a chance of surviving? Since the only possibility for rescue requires great efforts of rowing, the weakest will have to be sacrificed as it would be absurd to decide by drawing lots who should be thrown overboard. It can be argued that such an action is not unjust to those forced overboard, for they would drown anyway. If the captain does nothing, he is concerned that he will be responsible for the deaths of all those whom he could have saved.

On one hand, it can be argued that if nothing is done and everyone dies as a result, no one is responsible for the deaths. On the other hand, if the captain attempts to save some, he can only do so by killing others and their deaths will be his responsibility. This could be viewed as worse than doing nothing and letting everyone die.

What would you do?

In practice it is important for an emergency health worker to recognise when a situation creates an ethical dilemma

and to break it into its component parts in order to think it through. The worker should seek additional information (including the patient's viewpoint and capacity), and identify any relevant law and seek any available professional guidance. If the issue still concerns the worker after using his or her personal insights, feelings and instincts, then it should be shared and discussed with the senior member of the team or line manager. Sometimes this might be somebody not in the country but only available by telephone. An emergency health team deploying to another country should have a pre-identified ethical committee to which the issue can be taken forward if still unresolved. Where possible and appropriate, the ethical committee should include at least one member of the host country's ministry of health.

In the discussion the ethical committee will ensure the dilemma is subjected to critical analysis, seek consensus and be able to justify the decision with sound arguments. Members will aim to be constructive in working towards resolving any differences in viewpoint, listen carefully without interruptions, seek clarification using gentle questioning, respect cultural differences and be attentive to body language. Members will try to explain the context of their point of view and try to picture the other members' expectations of what they are saying. The discussion and outcome of the decision made should be clearly documented in the patient's notes if it is clinical and the operational log for anything non-clinical.

International Health Regulations

By Ariane Halm

A joint global approach to preventing and controlling infectious disease outbreaks is critical. International, multidisciplinary and multisectoral collaborations and partnerships are essential to strengthen international health protection. With this in mind, the International Health Regulations (IHR) were developed under the leadership of the World Health Organization (WHO) and constitute a legally binding instrument for all WHO member states. The IHR aim to help countries work together to prevent and respond to acute public health risks that have the potential to cross borders and threaten people worldwide.

The IHR were first conceived in 1969 to help monitor and control three serious diseases that had significant potential to spread between countries: cholera, plague and yellow fever. Initially, the emphasis was on sanitary conditions, services and procedures to be implemented and maintained at borders. In reality, the original IHR of 1969 were routinely ignored by countries.

Changes in disease dynamics and the lack of respect for the IHR (1969) framework led to a revision of the regulations in 2005 to target all health hazards (including infectious diseases, chemical agents, radioactive materials, contaminated food and potential others) through early detection and adapted response and containment at source. According to

the IHR (2005), member states should establish a strong national public health infrastructure connected to a global alert and response system, to strengthen and maintain the capacity to rapidly detect, report and respond to public health risks.

The IHR (2005) framework concerns the coordination and management of events that could pose a Public Health Emergency of International Concern (PHEIC). With its all-hazards approach, it explicitly defines the core capacities that need to be in place at different levels and institutions of a health system to be prepared to respond to an emerging health threat. Should a public health event occur within their territories, member states are required to assess it using a decision algorithm provided in Annex 2 of the IHR (2005) and to notify WHO of all qualifying events within 24 hours of their assessment.

According to the IHR (2005), a PHEIC constitutes a public health risk to other states through the international spread of disease that might require a coordinated international response. A PHEIC is a situation that is serious, unusual or unexpected, which has impacts on public health beyond the affected state's national border that may require immediate international action. Since 2009, there have been six PHEIC declarations: H1N1 influenza (2009), wild poliovirus (2014), Ebola virus (2014), Zika virus (2016), Ebola virus (2019) and COVID-19 (2020).

The capacity of member states to implement the regulations is monitored through WHO's IHR monitoring and evaluation framework. It consists of an annual, mandatory states parties self-assessment annual reporting process (SPAR), as well as three voluntary activities: after action reviews (AAR) assessing capacity functionalities during real events; simulation exercises (SimEx) assessing potential capacity functionalities during non-real events, and joint external evaluations (JEE) assessing core capacities to identify gaps and prioritise opportunities for improvement.

Dual use

By Janine Dywicky and Iris Hunger

Humankind has always used scientific discoveries and technological advances not just for bettering society but also for warfare and destruction. From hurling plague corpses into Caffa – a besieged city on the Crimean peninsula – in the 14th century to the intentional spreading of smallpox to immunologically vulnerable American Indians in North America in the 18th century, history tells us that medical technology and the life sciences are no exception. The 20th century was no better – during both world wars, Germany and Japan used disease against livestock and humans to gain military advantage, while in the 1980s, the Soviet Union developed mass production methods for anthrax-causing *Bacillus anthracis* as a biological weapon.

The phenomenon that the same thing can be used for good or bad, peaceful or hostile purposes is called 'dual-use' (DU). It has been defined by McLeish and Nightingale (2005) as follows: '[d]ual use is a term that is applied to the tangible and intangible features of a technology that enable it to be applied to both hostile and peaceful ends with no, or only minor, modifications'.

The DU phenomenon is particularly pronounced in the biological area. Because pathogens exist in nature, there may always be legitimate reasons to work with them. This is in contrast to chemistry and the nuclear field, where there are some clear-cut cases of hostile intention. The nerve agent sarin, for instance, has no peaceful purpose. The same is true, in the vast majority of cases, for highly enriched uranium. If sarin or highly enriched uranium are found somewhere, this is a clear indication of weapons development. In the biological field, the context must always be considered when judging whether an activity is for peaceful purposes. If a pathogen is handled in amounts that fit the stated purpose, if the activities are transparent and questions are readily answered, and if the expected results appear on the market or in publications, then it is likely that the stated peaceful purpose is indeed the true one.

With the increasing importance of life sciences research since the beginning of the current century, the term 'dual use research of concern' (DURC) has emerged. It describes areas of research that have a high potential for misuse. A high-misuse potential is determined by the immediacy and

impact of the research undertaken. Research that can be used directly for hostile purposes with few fundamental changes (high immediacy) and that poses a significant threat to humans, animals or the environment (high impact) is considered DURC. An example is the synthesis of the horsepox virus (see Box).

Synthesis of the horsepox virus as an example of DURC

Horsepox belongs to the same virus family as smallpox, an eradicated, highly deadly, highly contagious disease that is vaccine-preventable, but routine vaccination stopped globally in the 1980s. Based on the openly available DNA sequence, researchers used chemically synthesised DNA fragments to build a synthetic horsepox virus. Critics have argued that this work provides a recipe for synthesising smallpox and should therefore not have taken place.

Arguments in favour of the research

- To understand more about the origin of the smallpox vaccine (historical interest)
- To help develop an improved vaccine
- To demonstrate that synthesis of complex viruses is possible
- All methods used are well-known

Arguments against the research

- No improved vaccine is needed
- Access to pox viruses has become easier
- Decreasing immunity globally makes people ever more vulnerable to smallpox
- Only limited vaccine stockpiles for emergency vaccinations exist
- New and specific methodological detail has been published

Source: Noyce et al. (2018)

Generally speaking, the DU potential of activities can be expected to be very high if particularly dangerous pathogens are involved or if the activities conducted lead to an increase of the 'weapons characteristics' of agents, such as increased environmental stability or decreased effectiveness of therapeutics. Lists of agents, material and equipment that are considered DU vary globally. In the European Union, DU items are listed in the DU export control legislation.

In the context of health crisis deployments, DU is generally of limited concern. However, in outbreak situations of high consequence infectious diseases, samples taken for diagnostics, the patients themselves and even corpses should be considered potential sources of pathogens for people with hostile intent, and security should be implemented accordingly. For example, the terrorist group Aum sent followers to the Democratic Republic of Congo during the Ebola virus disease outbreak in 1992 to secure some Ebola virus samples. Fortunately, they were unsuccessful.

During deployments, especially in wars, war-like situations or after terrorist attacks, staff may come across stocks of dangerous material that could be used to harm people. In such situations, it is important to keep the DU nature of such materials in mind and secure them against unauthorised access.

Managing the risks of DU materials, equipment and activities requires compliance with legally binding regulations and adherence to other measures, such as professional

codes of conduct and institutional norms, rules and procedures on risk assessment and security. International legal instruments that contribute to reducing the potential for misuse of DU items include the Biological Weapons Convention (1972), the Chemical Weapons Convention (1993) and UN Security Council Resolution 1540 (2004). The transfer of dual-use items is regulated by a number of national and regional export and import controls (non-compliance can lead to penalties). Export controls are partly globally harmonised through the Australia Group, an informal arrangement of 40 participating states formed in 1985 in response to evidence that Western countries had inadvertently supplied Iraq with dual-use chemicals which Iraq had diverted to its chemical weapons programme.

Dual-use risk management may require biosecurity measures. For more information, refer to the section on Biosafety and biosecurity in Chapter 3.

Sustainable Development Goals (SDGs) and SDG 3

By Maike Voss

In 2015, the UN launched its Agenda 2030 and the Sustainable Development Goals (SDGs). Adopted by all member states, Agenda 2030 includes five core principles (people, planet, prosperity, peace and partnership) and 17 goals to achieve a better and more sustainable future for all, by 2030. The SDGs address global challenges such as poverty, inequality, climate change, health, environmental degradation, justice, peace and partnerships. All goals are connected to the overarching goal to ‘leave no one behind.’ In contrast to the earlier Millennium Development Goals (MDGs), the SDGs are a call to action for all countries – developed and developing – as well as for academia, the private sector, NGOs and international organisations.

SDG 3: Good health and well-being

SDG 3, which aims to ‘ensure healthy lives and promote well-being for all at all ages,’ is, according to Agenda 2030, essential to sustainable development. The World Health Organization (WHO) leads global efforts to achieve SDG 3. Ensuring health and well-being often relies on factors outside the health sector, so goals such as SDG 2.2 to ‘end all forms of malnutrition’ and SDG 16.2 to ‘end abuse, exploitation, trafficking and all forms of violence against

and torture of children' are also relevant. The translation of all SDGs into national, subnational and local policy action is key to achieving these ambitious goals. SDG 3 and other health-related SDGs can be used as a guide for project planning and implementation.

Health target	Description
3.1	By 2030, reduce the global maternal mortality ratio to less than 70 per 100,000 live births.
3.2	By 2030, end preventable deaths of newborns and children under 5 years of age, with all countries aiming to reduce neonatal mortality to at least as low as 12 per 1,000 live births and under-5 mortality to at least as low as 25 per 1,000 live births.
3.3	By 2030, end the epidemics of AIDS, tuberculosis, malaria and neglected tropical diseases and combat hepatitis, water-borne diseases and other communicable diseases.
3.4	By 2030, reduce by one third premature mortality from non-communicable diseases through prevention and treatment and promote mental health and well-being.

3.5	Strengthen the prevention and treatment of substance abuse, including narcotic drug abuse and harmful use of alcohol.
3.6	By 2020, halve the number of global deaths and injuries from road traffic accidents.
3.7	By 2030, ensure universal access to sexual and reproductive health-care services, including for family planning, information and education, and the integration of reproductive health into national strategies and programmes.
3.8	Achieve universal health coverage, including financial risk protection, access to quality essential health-care services and access to safe, effective, quality and affordable essential medicines and vaccines for all.
3.9	By 2030, substantially reduce the number of deaths and illnesses from hazardous chemicals and air, water and soil pollution and contamination.
3.a	Strengthen the implementation of the World Health Organization Framework Convention on Tobacco Control in all countries, as appropriate.

- | | |
|------------|---|
| 3.b | Support the research and development of vaccines and medicines for the communicable and non-communicable diseases that primarily affect developing countries, provide access to affordable essential medicines and vaccines, in accordance with the Doha Declaration on the TRIPS Agreement and Public Health, which affirms the right of developing countries to use to the full the provisions in the Agreement on Trade-Related Aspects of Intellectual Property Rights regarding flexibilities to protect public health, and, in particular, provide access to medicines for all. |
| 3.c | Substantially increase health financing and the recruitment, development, training and retention of the health workforce in developing countries, especially in least developed countries and small island developing States. |
| 3.d | Strengthen the capacity of all countries, in particular developing countries, for early warning, risk reduction and management of national and global health risks. |

Source: United Nations

The right to health and health equity

By *Hanna-Tina Fischer*

The *Constitution of the World Health Organization* (WHO), adopted in 1946, specifies that ‘the enjoyment of the highest attainable standard of health is one of the fundamental rights of every human being without distinction of race, religion, political belief, economic or social condition’. According to the WHO Constitution, health refers to ‘a state of complete physical, mental and social well-being and not merely the absence of disease or infirmity’.

This means that people all around the world – regardless of their age, gender, ethnicity, religion or level of income – have a right to attain the highest possible standard of physical and mental health. Moreover, this means that all member states of the UN have an ethical and legal commitment to uphold this right to health. Recognising that states face different structural factors and obstacles to realising these commitments, states are obligated to progressively support this right to health based on available capacities. The right to health includes an entitlement to health services, facilities and goods that are accessible, affordable, of good quality and not discriminatory, according to WHO and the Office of the UN High Commissioner for Human Rights (OHCHR). Beyond treatment, the right includes the right to prevention and control of disease, as well as the right for the various determinants or factors that influence health to be addressed.

Beyond the WHO Constitution, the commitment to health as a human right is further grounded in international human rights law. According to Article 25 of the 1948 Universal Declaration of Human Rights, 'Everyone has the right to a standard of living adequate for the health and well-being of himself and of his family, including food, clothing, housing and medical care and necessary social services.' The right to health is also included in the 1966 International Covenant on Economic, Social and Cultural Rights (ICESCR) and has been recognised or referenced in many international human rights treaties since then. As part of international human rights law, the right to health is of concern to all states. Every state in the world has ratified at least one convention that specifies the right to health and has therefore committed to upholding this right. A rights-based approach to health means that healthcare provision cannot be regarded as an act of charity, but as a responsibility in response to an entitlement.

Social determinants of health

Even though everyone has a right to health, people have different health outcomes based to a large extent on where they live. The latest *Global Burden of Disease Study* (GBD) highlights that although significant strides have been taken to improve the health and well-being of populations around the world over recent decades, global trends mask striking differences by gender and at country level. Life expectancy, for example, has increased from 51 years (48 years for males

and 53 years for females) in 1950, to 73 years (71 years for males and 76 years for females) in 2017, according to the GBD Mortality Collaborators. Even though it increased on average by 22 years overall in this period, it did not do so equally for all areas of the world. In Eastern and Central Europe, and Central Asia, the increase in life expectancy since 1950 has been just 11 years. Similarly, life expectancy in Sub-Saharan Africa is only 64 years for both men and women, nine years lower than the global average. There are also notable differences in mortality rates within countries. Young adult males in Eastern Europe and Sub-Saharan Africa, for example, have higher than expected mortality rates. Among other things, this can probably be attributed to an increase in the number of deaths from conflict and terrorism between 2007 and 2017.

These differences in morbidity and mortality are informed by what are called the social determinants of health, defined by WHO as ‘the conditions in which people are born, grow, live, work and age’ and ‘the wider set of forces and systems shaping the conditions of everyday life.’ These determinants are a critical concept as they identify the social, cultural and economic factors that affect the health and well-being of individuals. It is well-established that socioeconomic factors such as poverty, low income, occupational status and poor education determine the impacts of many diseases. As such, these factors are the cause of many health inequalities both between and within countries. In addition to socioeconomic conditions, the International Commit-

tee on Economic, Social and Cultural Rights (the body responsible for monitoring the ICESCR) has identified the following ‘underlying determinants of health’: safe drinking water and adequate sanitation, safe food, adequate housing and nutrition, healthy working and environmental conditions, health-related education and information, and gender equality.

Health equity

Addressing these social determinants of health, to enable equal opportunities for all to achieve the highest possible standard of health, means striving for health equity. Health equity refers to the absence of avoidable or unfair differences in health outcomes between groups of people. Inequity, therefore, refers to situations where groups of people are at a disadvantage which can be due to social, economic, geographic or other reasons.

Reducing health inequities, or the avoidable disparities in the health status of people, must be a priority for all states if we are to ‘leave no one behind’. Health inequities arise from inequalities that exist within and between populations in different countries. These inequalities include, but go beyond, the unequal distribution of wealth. Reducing health inequities means recognising the role played by the social and economic conditions in which people are born, live and work. These conditions determine the risk of illness that different people face and influence whether or not they can

access treatment for illness. Improving these conditions will improve their health outcomes. Health equity, therefore, lies in social and economic equity.

Child protection

By Hanna-Tina Fischer

Globally, violence against children is estimated to occur on a staggering scale, with an estimated 500 million to 1.5 billion children affected by different forms of violence annually. The impact on individuals, their families and wider society is substantial. Exposure to violence impacts children's physical, cognitive and social-emotional development, at all stages from infancy to young adulthood. The economic cost alone of the impacts of physical, psychological and sexual violence against children is estimated to be between 2% and 8% loss of GDP.

Even though children face protection risks in everyday situations – in their homes, schools and communities – humanitarian contexts in particular pose specific threats to children's safety and well-being. In emergencies, such as natural disasters and situations of armed conflict, children face risks of being separated from their caregivers, trafficked or exploited, recruited into fighting forces, or being injured or maltreated. Protection concerns for children in these settings also include dangers in the physical environment due to landmines or debris, and psychosocial distress from

exposure to traumatic events such as the loss of caregivers. In places with political, social and economic instability, institutions and services that provide for children, such as schools and hospitals, are often weakened or non-functional, with grave impacts on children's health and well-being.

Recognising these risks, specific protections are afforded to children in international human rights law and humanitarian law. The UN Convention on the Rights of the Child (CRC), for example, which is the most ratified human rights treaty in history and is applicable in emergency and non-emergency contexts, postulates that children everywhere have the right to develop to their fullest potential, the right to protection from harmful influences, abuse and exploitation, and the right to participate fully in family, cultural and social life. It protects these rights by setting standards in healthcare, education, and legal, civil and social services. With regards to humanitarian law, more than twenty provisions have been developed to give special protection to children affected by armed conflict in the Fourth Geneva Convention (1949) and the Additional Protocols of 1977. In addition, in 1999 the UN Security Council passed a resolution that condemned six grave violations against children during situations of armed conflict. A few years later, in 2005, a Monitoring and Reporting Mechanism (MRM) was established by Security Council Resolution 1612 to systematically monitor and report these six grave violations, which are:

- recruitment and use of children,

- killing or maiming of children,
- sexual violence against children,
- attacks against schools or hospitals,
- abduction of children,
- denial of humanitarian access.

Efforts by international development and humanitarian actors to prevent and respond to protection risks for children have continued to grow substantially over the past decade. Recognising the long term health impacts of violence against children, the World Health Assembly endorsed a WHO resolution in 2016 for a *Global plan of action on strengthening the role of the health system within a national multisectoral response to address interpersonal violence, in particular against women and girls, and against children*. According to the action plan, WHO member states are committed to monitoring the scope and scale of violence against children and implementing evidence-based strategies to prevent and respond to violence. The same year, the Sustainable Development Goals were launched which include several targets that call for the elimination of violence against children including Target 16.2 which aims to ‘end abuse, exploitation, trafficking and all forms of violence against and torture of children’. In 2019, the Alliance for Child Protection in Humanitarian Action published a second edition of its *Minimum Standards for Child Protection in Humanitarian Action* to promote the quality, accountability and coordination of responses to prevent and respond to

violence against children in humanitarian settings around the world.

Gender

According to UN Women, ‘Gender refers to the social attributes and opportunities associated with being male and female and the relationships between women and men and girls and boys, as well as the relations between women and those between men. These attributes, opportunities and relationships are socially constructed and are learned through socialization processes. They are context/time-specific and changeable. Gender determines what is expected, allowed and valued in a woman or a man in a given context. In most societies there are differences and inequalities between women and men in responsibilities assigned, activities undertaken, access to and control over resources, as well as decision-making opportunities. Gender is part of the broader socio-cultural context. Other important criteria for socio-cultural analysis include class, race, poverty level, ethnic group and age.’

This division leads to differences in status and the ability to access valuable resources, influence important decisions and seek protection. Women, men, boys, girls, transgender and others have different perspectives, needs and interests. A gender perspective implies that we understand these differences, in relation to each other and how they affect our work.

Gender equality and mainstreaming

Gender equality refers to the equal rights, responsibilities and opportunities of each member of society. It is a human rights issue and a precondition for and indicator of sustainable, people-centred development. Achieving gender equality does not happen overnight and cannot be imposed from outside. It involves the transformation of values and cultural practices. This process requires time and the inclusion of society as a whole.

Gender mainstreaming is the strategy to integrate a gender perspective at all stages of a project (planning, implementation, evaluation and follow-up) and at all levels of an organisation, mission or operation – everyone is responsible. The immediate purpose is to ensure that men, women, boys, girls, transgender and others will benefit equally from policies and actions, as well as to prevent external actors from exacerbating and perpetuating gender discrimination and inequalities.

International gender-specific legal frameworks

The following is a list of the most important international and regional frameworks and legal instruments, which focus on or include gender-specific provisions.

The Geneva Convention on the Protection of Civilian Persons in Time of War: Commonly referred to as the Fourth Geneva Convention (1949) and the Additional Protocols

(1977), these legal instruments stress the need for the special protection of women in warfare, including protection against rape and forced prostitution.

Rome Statute of the International Criminal Court (1998):

This is the treaty that established the International Criminal Court (ICC). It is the first document to declare rape and other forms of gender-based violence to be war crimes. If these acts are part of systematic and widespread attacks on civilians, they constitute ‘crimes against humanity’. Rape is condemned as a serious breach of international humanitarian law.

Convention on the Elimination of All Forms of Discrimination against Women (CEDAW) (1979):

Often considered as a ‘women’s charter of human rights’, CEDAW holds states responsible for adopting legislation and political measures to protect women and their rights, and to fight discrimination. General recommendation no. 30 on women in prevention, conflict and post-conflict situations gives guidance on concrete measures to ensure women’s human rights are protected before, during and after conflict.

In addition, there are regional legal frameworks, such as the Inter-American Convention on the Prevention, Punishment, and Eradication of Violence against Women (known as the Convention of Belém do Pará of 1994) and the Protocol to the African Charter on Human and Peoples’ Rights on the Rights of Women in Africa (known as the Maputo Protocol of 2003), which stipulates under Article 10 the Right to

Peace and under Article 11 the Protection of Women in Armed Conflicts.

Sexual exploitation and abuse

In 2015, allegations made against peacekeepers in the UN's peace operation in the Central African Republic raised a sensation. The AU, EU and UN repeated their zero-tolerance policies towards sexual exploitation and abuse (SEA) and reviewed their codes of conduct. The incident brought back memories of the 2002 'Sex for Food' scandal in which UN peacekeeping personnel and NGO workers traded food and money in return for sexual services with women and children in refugee camps in West Africa. Since then, the Inter-Agency Standing Committee (IASC) adopted a Statement of Commitment on Eliminating Sexual Exploitation and Abuse (2006), outlining six core principles; in March 2017, the UN Secretary-General announced a four-pronged strategy to prevent and respond to SEA across the UN system, appointing a Special Coordinator to lead that response through to the end of 2019; and in 2018 the Council of the European Union published Upgraded Generic Standards of Behaviour for CSDP Missions and Operations that include a section on SEA.

Both the UN and EU have adopted the following definitions:

Sexual exploitation refers to 'any actual or attempted abuse of a position of vulnerability, differential power or trust for

sexual purposes, including but not limited to, profiting monetarily, socially or politically from the sexual exploitation of another.’

Sexual abuse refers to ‘the actual or threatened physical intrusion of a sexual nature, whether by force or under unequal or coercive conditions.’

Most international and regional organisations have standards of behaviour or codes of conduct that condemn sexual exploitation and abuse as serious misconduct. Some missions have mission-specific codes or restrictions, which all categories of personnel have to respect. UN and EU staff members are strictly prohibited from:

- any sexual activity with anyone under the age of 18 years, even if he or she has been misleading about their age;
- any sex with prostitutes, whether or not prostitution is legal in their home country or the host country.

Some codes of conduct also prohibit using children or adults to procure sex for others and having sex with anyone in exchange for food, money, employment, gifts or services.

Perpetrators of sexual exploitation or abuse will risk ending their professional careers, quite apart from risking their personal safety and that of their victims. The UN can fine civilian perpetrators or – in the event of abuse by uniformed personnel – withhold payment to troop- and

police-contributing countries. Once the UN waives immunity of a civilian, he or she might face criminal proceedings.

Anyone who hears about sexual exploitation and abuse committed by mission personnel – whether suspicions, concerns, rumours or complaints – must report it to the head of mission or through specific conduct or discipline channels. Staff members who report possible breaches should be able to report anonymously and enjoy protection against retaliation.

Do No Harm

‘Do No Harm’ (context sensitivity) is a principle for the planning, evaluation and adaptation of assistance measures in crisis management. It is based on the understanding that any international involvement has unavoidable side effects. With this guiding principle, crisis management should be shaped in a way sensitive to the context in which it operates, so that its negative effects can be minimised.

The Do No Harm approach was developed at the beginning of the 1990s by non-governmental organisations (NGOs). Created originally for emergency aid, it has since been applied in all areas and phases of crisis management. One of the core assumptions of Do No Harm is that in every conflict, there are forces and structures present that promote or maintain violence, as well as forces and structures that promote peace. Crisis management should strengthen those

structures (e.g. dispute resolution procedures) and actors (e.g. moderate leaders) that can work positively towards a peaceful transformation of conflict.

International actors can cause damage by failing to act; equally they can cause damage by articulating or promoting their interests and priorities too vigorously. Such interventions can be perceived as biased or inappropriate. Depending on who is helped first, who receives benefits and which signals international actors send out, external aid can actually worsen conflicts and emergencies, even if unintentionally.

International crisis management is continually confronted with dilemmas. Achieving a wholly positive outcome is often not possible. From the start, the Do No Harm approach must be applied to the very analysis that provides the basis for an informed understanding of a conflict. During the implementation phase, it is necessary to continue examining interventions against the Do No Harm principle, so as to identify pitfalls and address them. By embracing this principle in all stages of their work, states, professionals have a chance to balance out imperatives of action while mitigating possible unintended and long-term consequences of their actions.

The Geneva Conventions

International humanitarian law (IHL) includes both humanitarian principles and international treaties to minimise suffering and damage during armed conflicts. IHL has been developed through the four Geneva Conventions of 1949 and the two Additional Protocols of 1977 relating to the protection of victims of armed conflicts. They represent the world's efforts to protect people in times of armed conflict and are based on the principles of humanity, impartiality and neutrality. The International Committee of the Red Cross (ICRC) serves as the guardian of IHL.

The four Geneva Conventions and the First Additional Protocol apply to all cases of international conflicts. These include declared war, armed conflicts or cases of partial or total occupation where two or more states are involved. The common Article 3 and the Second Additional Protocol, in contrast, apply to situations of internal, non-international armed conflict, such as civil wars.

The First Geneva Convention protects soldiers who are out of battle (*hors de combat*). This convention ensures the protection and adequate (medical) treatment of wounded or sick people during conflict. The convention encompasses the protection of medical personnel, equipment and facilities as well as the right of ICRC to assist people who are not or no longer participating in hostilities. It protects civilian support teams and prohibits violence and discrimination on the basis of sex, race, nationality, religion or political beliefs.

The Second Geneva Convention transfers the protection enshrined in the First Geneva Convention to wounded, sick and shipwrecked members of armed forces at sea.

The Third Geneva Convention sets out specific rules for the treatment of prisoners of war (POWs) and requires them to be treated humanely. POWs are to be housed adequately and should receive sufficient food, clothing and medical care. The convention also contains guidelines on labour, discipline, recreation and criminal trial.

The Fourth Geneva Convention regulates the protection of civilians in areas of armed conflict and occupied territories. Civilians must be protected from murder, torture, brutality, discrimination, collective punishment or deportation.

All four Geneva Conventions include an identical **Article 3**, which lays down the law during conflicts not of an international character. Under this article, those who have put down their weapons or are 'out of conflict' must be treated humanely and without any form of discrimination based on race, colour, sex, religion, social status or wealth.

The First Additional Protocol expands the protection of non-combatants such as civilians, military and civilian medical workers in international armed conflict. It forbids the recruitment of children into armed forces and determines that armed forces need to be recognised as combatants while preparing for or during an attack. It prohibits the misuse of protective emblems and forbids the

use of weapons that cause superfluous injury, unnecessary suffering, or widespread, long-term or severe damage to the natural environment.

The Second Additional Protocol, dealing with non-international conflicts, expands the common Article 3 of the four Geneva Conventions and extends the essential rules of the law of armed conflicts to internal wars. It protects victims, such as civilians, medical and religious personnel, shipwrecked and wounded people in internal, high intensity conflicts.

Biological and chemical weapons conventions

By Maria Hecht

The Geneva Protocol for the Prohibition of the Use in War of Asphyxiating, Poisonous or other Gases, and of Bacteriological Methods of Warfare, which was signed in 1925 in the aftermath of the First World War, is considered the founding document for the later-established Biological Weapons Convention (BTWC) and Chemical Weapons Convention (CWC). The First World War is known for the heavy use of chemical weapons. To stop the development of new weapons systems to use biological and chemical agents, the international community agreed on the Geneva Protocol. While the Geneva Protocol only refers to the *use* of chemical and biological weapons, the later-adopted BTWC

and CWC also prohibit the development, production and stockpiling of these weapons.

Biological Weapons Convention (BTWC)

The Convention on the Prohibition of the Development, Production and Stockpiling of Bacteriological (Biological) and Toxin Weapons and on their Destruction (BTWC) or, in short, the Biological Weapons Convention, was the first multilateral agreement to prohibit an entire category of weapons. It was opened for signature on 10 April 1972 and set into force on 26 March 1975. As at July 2020, it had 183 states parties and four signatory states. The BTWC is neither ratified nor signed by Chad, Comoros, Djibouti, Eritrea, Israel, Kiribati, Federated States of Micronesia, Namibia, South Sudan and Tuvalu. Review conferences on the BTWC are held every four to six years, with annual meetings of states parties since 2007 and annual meetings of experts since 2008. Decisions taken during the review conferences or meetings of states parties require unanimous agreement. All meetings are held at the UN in Geneva, Switzerland.

In contrast to the Chemical Weapons Convention, the BTWC has no organisation to monitor compliance with the treaty or to take measures in the event of an alleged use of biological weapons or any other alleged breach of the Convention. There is no UN agency that – without a decision from the UN Security Council – has the mandate to investigate a biological weapons attack. The only mecha-

nism legitimated to do so is the UN Secretary-General's Mechanism (UNSGM).

The second review conference to the BTWC in 1986 established so-called confidence-building measures (CBMs), further modified in subsequent years, 'in order to prevent or reduce the occurrence of ambiguities, doubts and suspicions, and in order to improve international co-operation in the field of peaceful bacteriological (biological) activities.' States parties are requested to submit information about the following: research centres and laboratories; national biological defence research and development programmes; any outbreaks of infectious diseases and diseases caused by toxins; certain publications, legislation, regulations and other measures; past activities in offensive and/or defensive biological research; and vaccine production facilities. States parties are obliged to share this information, which may be restricted to states parties only or made publicly available. However, since there are no measures in place in case the CBMs are not submitted, submissions are quite sporadic in many cases.

One of the main weaknesses of the BTWC is a missing verification system. Although discussions on this started in 1992, negotiations broke off in 2001 as some states parties considered the BTWC to be unverifiable. The main reasons included fast-developing technology and overlapping research and industrial or economic interests. In particular, there were concerns that a verification system could result in industrial espionage or violations of patent protection.

The states parties to the BTWC have organised themselves into various groupings: the Eastern European group (EG), the group of the Non-Aligned Movement and other states (NAM) and the western group (WG).

Chemical Weapons Convention (CWC)

The Convention on the Prohibition of the Development, Production, Stockpiling and Use of Chemical Weapons and on their Destruction, or short the Chemical Weapons Convention (CWC) was opened for signature on 13 January 1993 and set into force on 29 April 1997. As with the BTWC, it is a treaty prohibiting an entire category of weapons. It is also the first convention on the elimination of this entire category of weapons by a fixed date. To date, 98% of all declared chemical weapons in the world have been destroyed. As at July 2020, the convention had 193 states parties and one signatory state (Israel). Only Egypt, North Korea and South Sudan have neither signed nor ratified the CWC.

The conference of states parties to the CWC meets once a year and reviews the implementation of and compliance with the treaty. The conference may be convened, on special request by the conference itself, by at least one third of the states parties, or by the executive council, to meet more often. Since 2003, there has been a conference every five years to review the convention. Decisions are taken by a simple majority of present and voting states parties. They have organised themselves into five regional groups for

discussion, voting or strategic positions: Eastern Europe, Western European and other states group, Africa, Asia and the group of Latin America and the Caribbean.

The CWC is monitored by the Organisation for the Prohibition of Chemical Weapons (OPCW), based in The Hague, The Netherlands, and the treaty has a verification mechanism. In the event of an alleged use of chemical weapons, the OPCW may coordinate, oversee and evaluate an investigation, as happened with the alleged use of chemical weapons in Syria in 2013. The procedure stipulates that a team of experts should be sent to the affected region to take samples, which are analysed outside the country in designated and certified laboratories.

The daily routine of the OPCW includes inspections of the destruction of chemical weapons, as well as the onsite industrial inspection of facilities producing or processing chemicals that are listed under the CWC annex. To fulfil this task independently, the OPCW maintains its own specialist equipment for inspections or investigations. In 2013, the OPCW was awarded the Nobel Peace Prize for 'its extensive efforts to eliminate chemical weapons'.

UN Security Council Resolution 1540

UN Security Council Resolution 1540 was unanimously adopted under Chapter VII of the UN Charter by all members of the UN Security Council on 28 April 2004. It states

that the ‘proliferation of nuclear, chemical and biological weapons and their means of delivery constitutes a threat to international peace and security.’ Furthermore, Resolution 1540 directly refers to the biological and chemical weapons conventions and calls for their full implementation.

The 1540 Committee, established pursuant to Resolution 1540, comprises 15 current Security Council members and monitors progress on national implementation. Its mandate is coupled to the resolution and has been extended until the resolution’s next review in 2021. The 1540 Committee meets at the UN headquarters in New York.



Chapter 3

Taking a glimpse into the health environment*

This chapter aims to introduce some of the myriad of different health-related topics you may encounter during a deployment. While each topic is a separate discipline in its own right, it is important to understand how they are interconnected within the very complex web of the public health environment. A better understanding of the linkages between different health topics will improve the overall impact of emergency response.

* For full credits, references and further reading on the subjects covered in this Chapter, please refer to Credits & References Chapter 3 on p. 551

Anthropologists in emergencies – an introduction

By Heidi J Larson

Social scientists – most notably anthropologists – have come to play an increasingly significant role in health emergencies, given the growing recognition that success or failure of any intervention depends on effective communication and sensitivity to the perspectives and concerns of those being served.

Anthropologists use a variety of methods such as participant observation, in-depth interviews and focus groups to understand the felt needs of beneficiaries as well as to assess their willingness to accept – or not accept – whatever health interventions are involved. Where there is resistance, anthropologists can gather insights into the concerns that might inhibit individual or group acceptance of an emergency response measure.

Communities are too often regarded as single, homogeneous entities, missing the diversity of beliefs, trust relations and informal power structures that may be very different from formal power structures. While hierarchies need to be respected, those with less voice also need to be heard, particularly as their opinions and perspectives may not always align with those of key stakeholders or local authority figures. They can also disrupt efforts if they

feel neglected or marginalised by officials or international health responders.

Anthropologists' relationships in the community, built through research encounters, can be valuable to help solve problems and encourage compliance. Although social science has a reputation for being a slow science, there are anthropological methods – such as rapid assessment procedures – that can be particularly effective in informing humanitarian response interventions. While in-depth, detailed anthropological research conducted over an extended period of time remains important, social science research during emergencies such as the Ebola epidemic has demonstrated its value in providing real-time information and feedback crucial in engaging communities and supporting an effective emergency response.

The roles and methods of anthropologists and other social scientists are sometimes poorly understood by decision-makers and medical staff, especially when urgency is a priority. It is essential to communicate the anthropological approaches being used – particularly the relevance of 'community listening' to effective interventions – in order to ensure acceptance by others working in an emergency response.

Anthropological perspectives in health emergencies

By Hansjörg Dilger and Sung-Joon Park

Health emergency missions are often deployed in settings with complex histories of colonialism and postcolonial injustices, which have made people suspicious towards outside interventions. These outside interventions may be run by global health agencies, but include interventions by – or in cooperation with – national, regional and local state authorities and NGOs.

Humanitarian organisations agree on the fact that a militarised health intervention to enforce public health measures may exacerbate conflict, mistrust and resistance. Instead, an intervention needs to build trust so that communities come to accept public health measures, even if they challenge social obligations, moral values and customary practices. However, it is important to note that these challenges may not necessarily refer to the public health measures themselves, but often revolve around how these measures are implemented, by whom and with what agenda.

Potential conflicts between response teams and communities can be avoided by doing things in locally acceptable ways and thereby building trustful collaborations between the mission and communities. It is crucial to understand the social, political and moral dimensions of an emergency intervention from the perspectives of the communities

themselves. In addition to the technical and medical evaluation of an intervention, response teams must recognise what matters to local communities and how they assess and evaluate the intervention.

Medical anthropological perspectives are useful to identify the diversity of concerns at community level, how these concerns have been emerging, who is involved in potential or existing conflicts, and how to adapt response strategies accordingly. Some of the key measures to establish trust at community level include:

- recognising the internal diversity of a community;
- understanding health-seeking behaviours in a context of medical pluralism;
- involving local ('traditional') healers and religious leaders;
- acknowledging the needs of home carers;
- respecting customs of burial and grief.

Recognising diversity

An important point of departure for building trust is to recognise that communities in low- and middle-income countries (LMICs) are characterised by an enormous cultural, political and economic diversity. Recognising diversity within and between communities is an essential step towards a respectful community engagement. This means that, alongside the partnership with local and national state authorities, responders must engage local stakeholders – including customary leaders, village leaders and religious leaders – in the response. In semi-urban and urban settings, professional associations, such as associations of journalists, taxi drivers' unions, women's and youth associations, or traditional healers, represent important groups of relevant stakeholders. The identification of these stakeholders should be a comprehensive and open process, adjusted to the specific context.

It is likely that several different languages will be used in such diverse settings. The official language, English, French, Portuguese or Spanish, may not be the language that all community members identify with. The choice of language for everyday communication requires a sensitivity for the politics of language in these settings.

Recognising diversity is an essential element of grounding an intervention in mutual respect. In practice, communities often report ethnic, racial and gender discrimination. It is vital to take these experiences seriously and monitor

where discrimination happens, how it happens and prevent it – whether, for example, it is in the recruitment process of local staff and their payment, in the procurement of goods and services, or simply through the use of derogatory language. Missions must put codes of conduct in place and ensure all staff adhere to them. Members of a mission should cultivate an ethic of respect and decency in their community engagement, through being sensitive to the diversity of local values and norms.

Often it is nurses, volunteers and other frontline health workers working closely with communities who know the most respectful and appropriate ways to communicate and interact. Response agencies should actively involve these professionals in devising communication strategies for building trust.

Finally, trust is closely related to credibility, which is best achieved by demonstrating professional work ethics that adhere to principles of transparency, accountability and fairness. Missions should establish channels through which a variety of community members can articulate their concerns, even during emergency situations.

Health-seeking in the context of medical pluralism

In LMICs, there can be varying understandings of illness and its causation, including how the spread of new and existing diseases can be prevented. In a health emergency,

it is important to gain a basic understanding of this ‘medical pluralism’ to establish successful measures for the prevention and treatment of an infectious disease.

Biomedicine – often labelled ‘western’ or ‘modern’ medicine – has become a part of people’s lives everywhere. We grow up with it, we learn about it in school or public health campaigns, and most of us are usually familiar with biomedical conceptions of the body and disease transmission. We seek biomedical treatment – in hospitals, clinics or through self-treatment with non-prescription drugs – for all types of ailments, from a common cold to malaria. In regions with underfunded public health systems, the private health sector, with its small drug shops and private clinics, may play an important role in enabling this health-seeking behaviour.

However, biomedicine usually co-exists with other medical and healing traditions. Alternative types of medicine include, among others, Chinese medicine, homeopathy and different kinds of herbal medicine. In addition, illness and suffering may be perceived as caused by witchcraft or the breaking of a cultural taboo. In times of illness, people may make use of Islamic medicine, Pentecostal healing, or other types of spiritual healing. Most of these different types of alternative medicine or religious healing deploy a holistic understanding of the body and illness causation. They can provide moral, social and religious explanations of an illness and how healing can be achieved.

In people's everyday lives, these various types of medicine and healing may be in conflict with each other, but often they are used in a complementary way. People may go to the hospital or clinic for the treatment of their disease, but simultaneously – or at a later point – seek treatment for witchcraft, make use of herbal remedies, or look for healing in a local church. Some key questions for understanding the plurality of health-seeking behaviours are below.

- Which are the providers for biomedical treatment in a given setting and what hierarchies exist between them (hospitals, dispensaries, clinics)?
- How relevant are private health providers for people's health-seeking?
- What kind of alternative or religious healing traditions exist and by whom are they provided?

Traditional healers and religious leaders

When people seek treatment and healing in the context of medical pluralism, they may refer to different types of biomedical practitioners in a variety of institutional settings (hospitals, dispensaries, clinics, local drug stores, public and private). At the same time, many of them rely on local healers and religious practitioners who often provide diverging explanations for their illnesses and may have longstanding and trustful relationships with their patients and their families.

Local medical healers and religious practitioners are referred to by a broad spectrum of terms, but the most common term is ‘traditional healer’ or simply ‘healer.’ Other local terms like *guérisseur* or ‘witchdoctor’ may be used, although terms such as ‘witchdoctor’ may have negative or derogatory connotations. Different types of healers may be in competition with each other, but they may also cooperate individually and in certain cases also with local biomedical authorities.

Religious leaders are important for giving spiritual and moral guidance in the context of a health emergency. However, some of them – for instance the leaders of the rapidly growing Pentecostal churches, but also Islamic leaders or the leaders of indigenous religions – may also promise healing for all kinds of ailments. It is important to understand what role these religious leaders – and the churches, mosques or groups they belong to – play in health-seeking. It is also crucial to involve them early on in a health emergency response.

Mission teams should consider the questions below.

- How do you involve different types of healers to improve health communication and reach different population groups?
- What are the local terms for traditional healers and with what connotations are they used?

- How do you include religious practitioners in the emergency response, when their promises for healing may conflict with biomedical prevention and treatment?

Home Care

In LMICs, many people earn their daily income in the informal sector, they lack health insurance and public healthcare services are limited or difficult to reach. In such contexts, home care is a common practice. Family members, close friends and relatives will either provide care for their loved ones themselves or mobilise resources to provide the best possible care. Often, care is provided by female relatives, in addition to their other income-earning and household obligations.

The meaning of care is shaped by social expectations, moral obligations and emotional needs for proximity. During a health emergency, particularly during infectious disease outbreaks such as Ebola virus epidemics, practices of home care pose a challenge to public health measures that separate sick patients from their relatives and communities and provide care and treatment under strict isolation. This conflict between moral obligations and public health measures puts enormous pressure on families and creates tensions between caregivers and responders.

To avoid these tensions, it is important to find ways to respect caregivers' moral and emotional desire to partici-

pate in the provision of care and seek ways to maximise social proximity, while maintaining physical distance – for example by providing sufficient possibilities for relatives to visit their loved ones. Social proximity can be achieved by employing members from the community in the response or involving survivors early on in the provision of care to sick patients. An empathetic approach to care and treatment can minimise relatives' feelings of separation from their loved ones.

The following approaches by responders can help acknowledge the needs and existing dynamics of home care:

- recognise that patients are not just sick individuals who require medical treatment but are embedded in a field of social expectations and moral obligations;
- respect the moral and emotional concerns of caregivers for their loved ones;
- find ways to allow social proximity while maintaining physical distance;
- train and involve community members and survivors as caregivers in the response.

Burials

Care for loved ones is provided both before and after a person's death. In many African settings, deceased relatives are buried on the family compound, observing extensive ritual requirements. The burial of a family or community member in a public graveyard may be seen as cutting social and spiritual ties with the deceased person. In such communities, burials by health workers or in mass graves are particularly painful. The use of body bags, disinfectants, personal protective equipment and other measures to prevent disease transmission offends communities who are in grief.

Most health emergency interventions have now adopted a model of dignified safe burials, which organises safe burial practices in ways that respect local customs and express sensitivity towards the emotional pain of communities. In practice, however, burials are very often a source of tension between responders and communities in grief, because each burial situation can give rise to unexpected conflict over the way dead bodies are handled.

Hence it is of utmost importance to put in place a protocol for dignified safe burials, which is tailored to a specific setting. It is crucial that burial team members are well-trained and have access to psychological support to better cope with stressful situations posed by burials and to maintain an attitude of respect and empathy.

Mission teams should keep the following in mind:

- identify a suitable protocol for dignified safe burials and adapt this protocol to local settings;
- provide comprehensive training to and support for burial team members;
- involve the community and survivors in collective rituals of mourning and remembrance.

Biosafety and biosecurity

By Jana Wolf

International health emergencies and the spectrum of biological risks

Some public health events might develop into an international public health emergency. A strategy to protect a population against such emergencies must consider a diverse spectrum of threats, including endemic diseases, natural outbreaks or pandemics, accidents involving biological agent release, bioterrorism attacks and biological warfare, all of them having a wide range of potential consequences.

The release of highly pathogenic biological agents could pose significant challenges to national and global security by threatening public health and safety, destabilising society by stoking fears, undermining national economies, and affecting international trade and travel. This is independent of whether the biological incident is naturally occurring, accidental or intentional in nature.

Given the risks posed by highly pathogenic biological agents to public health, societies and economies, it is essential to work on preparedness in the following areas: detection and diagnostics of pathogens to treat patients during disease outbreaks; measures to prepare for diseases which might reoccur; steps to address new infectious diseases; and research to understand how pathogenic organisms work,

to help develop appropriate vaccines and drugs. To carry out this work, it is imperative to work with live biological agents, but this includes risks as well as benefits, since infectious pathogenic material could escape accidentally or might be intentionally misused.

To provide a public health response to the international spread of disease in ways that are commensurate with and restricted to public health risks, the WHO's International Health Regulations (IHR) help to monitor and control such events by ensuring early warning and efficient international management of a biological incident, through consistent policies, operating procedures and requirements around operational and technical capacities. The IHR emphasise the importance of integrating biosafety and biosecurity into core laboratory capacity, without which laboratories cannot effectively support a public health system.

Strong laboratory capacity is an essential link in the chain to control disease outbreaks. In the context of such outbreaks, examining diseases from different kinds of investigations, such as blood and tissue samples of patients as well as culture plates of pathogens, is a daily routine. However, diseases under examination may be caused by highly pathogenic viruses or bacteria. The handling of these is of biosecurity concern, since these infectious pathogens may affect the health of humans, animals and plants when released. Any activity related to infectious pathogens or toxins therefore involves an inherent safety and security

risk with regard to biological agents, hence the need for biosafety and biosecurity.

Biosafety and biosecurity: two approaches – one goal

Multiple definitions of biosafety and biosecurity exist. Some languages even translate both terms into the same word or fail to differentiate their meanings. ‘Biorisk’ encompasses both biosafety and biosecurity.

According to WHO’s 2004 publication *Laboratory Biosafety Manual*, laboratory biosafety describes ‘the containment principles, technologies and practices that are implemented to prevent unintentional exposure to pathogens and toxins, or their accidental release.’ WHO’s 2006 publication *Biorisk management: Laboratory biosecurity guidance* defines laboratory biosecurity as follows: ‘the protection, control and accountability for valuable biological materials (VBM) within laboratories, in order to prevent their unauthorized access, loss, theft, misuse, diversion or intentional release.’

Biosafety and biosecurity are both different approaches to ensure containment and both share the goal of minimising the risk of accidental or intentional exposures and releases of pathogens or toxins. Although they share a common goal, they address different risks – biosafety targets accidental or unintentional releases, while biosecurity addresses the intentional release of pathogens.

Biosafety includes safe practice and protective measures for working with infectious micro-organisms and dangerous biological material, such as technical, organisational and person-related measures to prevent laboratory associated infections.

Biosecurity includes secure practices and protective measures to address laboratory risks and threats beyond the scope of accidental exposure, such as the unintended consequences of research, but also criminal activities, sabotage and isolated acts of aggression associated with the deliberate intent to cause outbreaks or misuse pathogenic agents. Thus, biosecurity includes risks associated with the issue of ‘dual use’ of the life sciences, elaborated on further in Chapter 2.

Biosafety: Protect the people from the pathogens

Biosecurity: Protect the pathogens from the people

Both approaches address different risks and complement each other to cover all related hazards, so many elements of biosafety are shared with biosecurity. This work is completed by bioethics, defined by WHO as ‘the study of the ethical and moral implications of biological discoveries, biomedical advances and their applications’.

From risk identification to applied biosafety and biosecurity

Working with infectious material carries a biosafety as well as a biosecurity risk. This risk must be considered in any environment, whether it is an outbreak, hospital, laboratory or teaching setting.

In every setting, infectious pathogens and toxins can be stolen, lost or used intentionally for malicious purposes. Biosecurity risks are difficult to identify because they are potential and dynamic, rather than static, and are posed by an *individual*. By contrast, biosafety is concerned with risks posed by a *hazard*, a source or object that can cause harm. In biosecurity, however, the potential threat refers to a person who has intent to cause harm to other people, animals or institutions.

Many of the pathogens that medical, scientific and technical staff work with are readily available in nature. However, individuals who wish to acquire materials and knowledge may access these more easily from facilities where a large number of pathogens and toxins are located and stored. The suitability of a pathogen or toxin for malicious purposes determines the level of biosecurity risk.

To manage biosafety and biosecurity risks, the following key components need to be considered: **Assessment – Mitigation – Performance** (AMP Model). These steps have to be repeated frequently.

Assessment

Assessment of risk factors includes:

1. hazardous characteristics of the biological agent (agent assessment);
2. hazardous laboratory operations;
3. capability of laboratory staff to control hazards (training, technical proficiency, good habits);
4. evaluation of threat environment;
5. vulnerability assessment;
6. risk characterisation by evaluation of the likelihood and consequences of an adverse event.

Existing biosafety-level or risk-group classifications can help to assess the biosafety and biosecurity risk. Some of these risk factors are examined in more detail below.

Hazardous characteristics of biological agents are determined by the following:

- pathogenicity (for humans and / or livestock);
- infectious dose;
- mode of transmission (transmissibility to the community);
- host range (e.g. vectors, environmental hygiene);
- availability of effective preventive measures (e.g. prophylaxis, food and water hygiene, control of animal reservoirs);

- availability of effective treatment.

The hazardous characteristics of a biological agent are often the basis for the definition of defined risk groups (WHO risk groups: 1, 2, 3 and 4) or hazard groups (Public Health England (PHE) hazard groups: 1, 2, 3 and 4). This risk group classification is to be used for laboratory work only.

Specific laboratory sections are labelled with laboratory biosafety levels. These relate to (but do not equate to) risk groups of biological agents worked on within that specific laboratory section. The labelling of laboratory biosafety levels does not always equal the risk group of the biological agent worked on within that laboratory, because the determination of the laboratory biosafety level is based on not only the hazardous agent characteristics but all six risk factors mentioned above (including, for example, laboratory operations used).

Hazardous laboratory operations include:

- type of work (e.g. *in vitro*, *in vivo*);
- quantity / concentration;
- aerosol formation (e.g. pipetting, centrifuging);
- sharps (e.g. emptying of vessels and syringes, cutting of samples);
- contamination (e.g. opening of sample vessels, work with open cultures);

- accidents (e.g. breakage, leakage / spill, mishandling).

Based on the result of a risk assessment, appropriate biosafety and biosecurity mitigation measures are determined to minimise the release of infectious pathogens. Management must distinguish between acceptable and unacceptable risks to ensure that the cost of protection is proportional to the risk.

Mitigation

Biosafety mitigation measures fall into the following hierarchy of controls:

- elimination (physically remove the hazard);
- substitution (replace the hazard);
- engineering controls (physical measures to isolate people from the hazard);
- administrative controls, practices and procedures (change the way people work);
 1. protect the worker with PPE (personal protective equipment).

Biosecurity mitigation measures fall into the following elements:

1. physical security;
2. material control and accountability;
3. transport security;

4. personnel security;
5. information security;
6. training and awareness;
7. biosecurity management.

Performance

The final step is to frequently review the performance of the implemented measures to improve the management of biosafety and biosecurity risks. The three components of performance are control, assurance and improvement, to receive confirmation that the system works, that it is sustainable and that the risk is acceptable. The validity of the existing risk assessment is checked at regular intervals and the following steps are repeated.

Risk communication

In addition, it is important to ensure effective risk communication, to establish trust between the community and the organisation dealing with the biosafety and biosecurity risks. Informing people about threats to their environment or health and warning of potential emergency situations will encourage prudent action and reduce panic.

Risk communication => Things that might go wrong

Crisis communication => Things that do go wrong

To ensure effective biosafety- and biosecurity-related risk and crisis communication, there is a need to distinguish between objective and subjective risk. Objective risk is

calculated by scientific or medical staff based on research and facts. Subjective risk is what the public perceives as a risk. The assessment of subjective risk is most important for successful communication.

Biosafety and biosecurity in health emergencies

It is essential to strengthen global efforts to protect and defend against biological threats and improve containment and response to outbreaks of diseases, whether due to natural, accidental or deliberate causes. In this context, biosafety and biosecurity are essential pillars of international health security.

- Be aware that there might be biosafety and biosecurity issues connected with your work.
- Be aware that the levels of safety and security awareness, as well as of threat perception, vary widely from country to country and person to person.
- Be aware that the implementation of biosafety and biosecurity best practices is supported by an appropriate legal framework.
- Assess possible biosafety and biosecurity risks, use appropriate mitigation measures and review the performance. Get support if necessary.
- Take into consideration principles of risk and crisis communication.

Clinical facilities and management

By Gerald Ripberger

Mapping the health infrastructure when on mission

The health infrastructure includes all facilities needed for the transport, diagnostics and treatment of patients, starting from basic level healthcare up to highly specialised hospitals. The health infrastructure should provide all services from prevention to the treatment of minor up to severe diseases and injuries, as well as rehabilitation and aftercare.

The mapping of health infrastructure should identify acute challenges facing the health infrastructure, for example pandemics, to understand the impact on the mission. Mapping is recommended for the facilities outlined below.

- **Primary healthcare:** preventive, promotive, curative and rehabilitative medicine, including general practice and dentistry.
- **Secondary healthcare:** first referral level, specialist treatment up to hospital treatment in general wards.
- **Tertiary healthcare:** second referral level, more specialised hospitals than in secondary healthcare up to university hospitals, specialised hospitals (e.g. psychiatric care facilities, children's hospitals, eye clinics).

- **Comprehensive care facilities:** e.g. emergency medical services (ambulance services), pharmacies, labs and diagnostics.
- **Other facilities** related to the healthcare system that may be essential for the mission.

Hospitals are classified from Level 1 (small facility with no specialisation) up to Level 4 (highly specialised hospital, e.g. university hospitals). Military hospitals are labelled from Role 1 (advanced first aid point) up to Role 3 (specialised facilities, such as field hospitals). Other organisations usually use a ranking from 1 to 3 or 4, from low care to high care.

Gaps in the healthcare system have to be identified and alternative solutions established within the mission or by cooperation with governments, non-governmental organisations or private institutions. The quantity and quality of such facilities varies widely. It is not easy to measure the quality of a healthcare system, especially during an emergency. But it is possible to gain insights by understanding the facilities that are available for treating patients. Some key questions are outlined below.

- What kinds of medical facilities are necessary to implement the mission?
- Where are medical facilities located, in respect of different levels of care?

- How can I reach them? Is there a transport service available and does the service provide medical care or only transport?
- Is there 24/7 access to the facilities?
- What are the qualifications of the staff? Do they offer specialised therapies? Do they have an ICU?
- Which facilities can manage infectious or highly infectious diseases?
- Are there obvious problems with hygiene?
- Do they follow international standards in examination and therapy, e.g. Advanced Trauma Life Support (ATLS™)?
- Is there a blood bank available with sufficient supplies? Is there a quality management system established?
- Are the facilities accredited by the public health authorities?
- Are the facilities recommended by other organisations?
- Is the health situation expected to deteriorate within the next few days and are the facilities prepared?

This mapping should start before the mission deploys. Much information will be available online (e.g. on the webpages of WHO, foreign ministries, providers of medical evacuation services), but this information should be verified on arrival. Medical missions will need to monitor the unfolding health situation and the response of local health

institutions carefully. A contact inside the public health authority should be established early on in the mission.

For more information, the Inter-Agency Standing Committee and the Global Health Cluster have published a helpful checklist entitled *Health Resources Availability Mapping System*.

Referral mechanisms and destinations

The referral mechanism is the process of guiding a patient to another professional who might provide further care and more specialised examinations and investigations than the referring facility can provide. Referral is usually from lower to higher level care, from general to specialised or intensive care. Convenient referral destinations need to be identified in advance by mapping the healthcare system, including at least one fall-back option. Referral can progress from moving a patient to a specialist (outpatients) unit, to hospitalisation and finally medical repatriation.

A referral usually includes the steps outlined below.

- 1. Diagnosis:** a medic or medical doctor must approve the diagnosis justifying the need for a referral.
- 2. Referral form:** this must include at least the reason for referral, the patient's history, results of examinations, the current list of medication, special patient conditions (e.g. allergies), an address to send results

to, and the date and signature of the attending medical practitioner. The patient should provide their vaccination card. The documents should be written in the most-understood language in the mission's area to avoid misunderstandings. A copy needs to be stored in the patient's medical file.

3. **Availability**, operativeness and suitability of the receiving facility must be checked. The destination will depend on the result of the initial mapping of the health infrastructure. It is mandatory to inform the receiving medical facility about suspicions or confirmation of an infectious disease. A verbal or written (and confirmed) advance notice is mandatory for all referrals.
4. **Transport** to the destination has to be organised in accordance with the health conditions of the patient.
5. A regular **exchange of information** about the conditions of the patient between the referring and receiving medical facilities must be established.
6. **Medical documents** must be secured after discharge and/or medical repatriation, and after closing the medical file, if conditions allow.

If there is no specialist available, consider an early medical repatriation after consulting the mission's medic or physician in charge.

Patient transportation options

Although patient transportation services are available in the majority of countries, it cannot be assumed that they are available everywhere. The quality and quantity vary. This must be considered in mission planning. If it is necessary to organise medical transport for a mission member, it is recommended that the mission provides an escort.

In general, there are two options available: non-emergency medical transportation and emergency medical transportation for patients with acute complaints or in critical condition. In exceptional cases, medical repatriation to the country of origin may be the best option. For all options, the costs and method of payment have to be considered in advance. Insurance companies may be helpful in organising transport.

Non-emergency medical transportation

This does not need medical personnel in attendance, although a wheelchair or stretcher may be needed. The most common non-emergency medical transportation will be in the mission's car or a taxi, accompanied by another mission member. This type of transport is appropriate only if the patient is in a stable health condition, has no infectious disease, does not need medical supplies or support – but needs help accessing care.

Emergency medical transportation

For cases of acute or critical care, the emergency medical services may provide one of the options below.

Basic life-support (BLS) ambulance

This is the transport option for patients in a stable condition who need medical attendance or medical supplies. The driver is accompanied by a nurse or emergency medical technician to deliver the medical assistance.

Advanced life-support (ALS) ambulance

This is the option for patients with more severe illnesses or injuries. ALS ambulances have the necessary equipment and medication to stabilise and monitor the patient up to resuscitation. Apart from the driver, an intensive care nurse or paramedic provides the medical assistance.

Emergency physicians

In some countries, patients in an unstable condition can receive support from emergency physicians, who will join the BLS or ALS ambulance, depending on the context of the emergency. Often the emergency physician will drive or even fly in on their own transport for a rendezvous with the BLS or ALS ambulance.

Air transportation options (medical evacuation)

Helicopters are used in the emergency medical services for transporting medical personnel to the patient or,

less often, the patient to a hospital. Helicopters provide a fast, smooth service and are equipped similarly to an ALS ambulance. Depending on the type of helicopter, there is usually no space for resuscitation, so the patient has to be stabilised before take-off. Availability of helicopters is dependent on good weather conditions and daylight hours.

Fixed-wing aircraft (ambulance planes) are also used for medical transportation, especially in large countries. They are usually organised by the insurance company or a contracted provider. The transport is fast and smooth, but there are logistical concerns to keep in mind, outlined below.

Medical transport has to be organised, both to the departure airstrip and from the arrival airstrip to the hospital.

Availability of planes depends on good weather conditions and – if the airstrip is not illuminated – daylight hours. Some organisations provide mobile illumination. This should be checked in advance when planning a mission in an area without hospitals.

The airstrip has to be in good condition and long enough for the aircraft. The provider of the flight service has to check this before departure.

The decision on which resource to use is generally done by a medical doctor or specialist who assesses the condition of the patient in coordination with the medical (or military) dispatch centre.

Medical repatriation

Medical repatriation is transportation back to the patient's country of origin, because of a medical problem. It is recommended if there is no possibility of treating a team member in the mission's area within an acceptable timeframe or to the right level of quality. Repatriation is usually by air, with the above-mentioned logistical constraints. The decision to repatriate must be taken swiftly, before the patient's condition worsens and they become unable to fly. In most organisations, a special headquarters unit will manage medical repatriations, through a contracted provider or sometimes by military or other designated service. It is important to involve mission headquarters and the transport provider at an early stage in planning. Local support (e.g. preparation of transport documents) should be provided by designated mission members.

Medical repatriation can also be by car, ambulance or scheduled flight, depending on the patient's condition and the distance. The question of who will cover the costs in case of medical repatriation must be clarified in advance.

Access to medicines and medical supplies

Handling medical supplies and drugs is a highly sensitive process within mission preparation, implementation and termination. Many legal aspects have to be respected, affecting the countries of origin and destination.

In general, the mission should provide all the medicines and medical supplies it needs for its own staff members for at least the first two weeks of operations. For missions with a medical mandate, this would also include medicines for patients. There is no guarantee that good quality medicines can be procured, especially in low-income countries. The following problems may occur:

- the prescription, if needed, must be done by a local physician or pharmacist;
- there may be a lack of trained staff to advise on usage;
- there may be limited availability on the local market;
- drugs may be counterfeit (e.g. no dose or unknown amount of the active ingredients), or lack certification;
- storage conditions may be poor (especially too much heat or moisture);
- packaging may be unavailable or damaged (with no clear expiry date);
- there may be no information included on the drug, or information is only in a foreign language;
- the quality of products could be poor.

In addition, buying a large amount of medication or medical supplies on the local market may lead to an increase in price for the local population.

The import of medicines and medical supplies involve specific formalities, which vary according to local laws and customs, especially for a significant quantity of supplies. There will be delays at customs. The supplies need official approval in the country of destination, and this has to be checked in advance by the local ministry of health or assigned authority. Some medicines may not be permitted, while others may fall under special restrictions, e.g. narcotics. A medical waste management system has to be established by missions at an early stage.

Before finishing the mission, there must be an exit strategy for what to do with unused medicines and medical supplies. Donations to local health facilities, confirmed by a letter of acknowledgement, may be one of the best options. But for this, the supplies must be of good quality, with enough time before expiry and with labels in a language that can be understood by future users. If this is not possible, the supplies must be destroyed in accordance with WHO recommendations and national protocols.

Fatality management

Fatality management is defined by the US Centers for Disease Control and Prevention (CDC) as ‘the ability to

coordinate with other organizations (e.g. law enforcement, healthcare, emergency management, and medical examiner/coroner) to ensure the proper recovery, handling, identification, transportation, tracking, storage, and disposal of human remains and personal effects; certify cause of death; and facilitate access to mental/behavioral health services to the family members, responders, and survivors of an incident.'

The responsibility of healthcare and fatality management professionals is to ensure the respectful and orderly management of deceased persons. Before death, however, it is mandatory to provide first aid until the death is confirmed. An exception is if there is severe risk to the first aid provider while delivering first aid.

Reliable signs of death are injuries that are not compatible with survival (e.g. decapitation), postmortem lividity, rigor mortis and decay. Usually, the death has to be confirmed by a physician, a coroner or another assigned authority. Two scenarios are explored in more detail below.

Death of a team member

If the worst comes to the worst and a team member dies during the mission, it is important to organise the correct and respectful handling and repatriation of the human remains as follows:

- contact the head of mission and the headquarters immediately;
- inform the deceased person's embassy or consulate;
- contact local authorities (police, public health institute), ask for the official regulations and a certificate of death and of the cause of death;
- ensure the identification and storage of the dead body is in accordance with the procedures of local authorities;
- accompany the human remains until repatriation;
- inform the other team members and offer them mental health support;
- the head of mission or headquarters should inform the family of the deceased.

Death of other persons

Dealing with dead bodies is most likely to occur on a medical mission, but it can also happen to first aid providers. It is necessary to call the local emergency medical service and/or the police and public health authorities, depending on the situation. The deceased person will get handed over to an official authority, to certify the death and cause of death. Usually these authorities will take care of the future management of the body. Correct documentation is mandatory in the medical file, if the deceased is a patient of a medical mission. In the case of a first aid provider or an individual handling a dead body, detailed personal documentation of the situation is highly recommended, in case there are any

subsequent requests from the authorities. Keep in mind cultural, religious and local customs.

How to deal with (potentially) infectious bodies?

Dead bodies do not usually cause epidemics. However, there are some exceptions, including highly infectious diseases such as Ebola, cholera or Lassa fever; so all human remains must remain suspected of harbouring communicable diseases until the cause of death is clarified. The process for dealing with infectious bodies depends on the legislation and operating procedures of the public health authorities in the country of the mission. So it is important to clarify these procedures with the local authorities. A clearance is usually necessary. If the death was caused by a disease such as viral influenza or COVID-19, the body should be packed in a body bag. This bag must be waterproof and clearly marked as infectious. The transport should be organised in an air-tight coffin. If team members have to come into contact with the human remains (e.g. for the preparation of the transport), the following safety actions have to be taken:

- minimise the time of contact;
- avoid movements which cause aerosols;
- wear stable and waterproof clothes;
- wear protective clothing with mask and water-repellent gown;
- wear safety glasses and/or a safety shield;

- don't forget the disinfection or washing of hands, arms and other possible contaminated surfaces.

WHO provides helpful information on dealing with bodies in mass fatality incidents in its 2006 publication *Management of Dead Bodies After Disasters: A Field Manual for First Responders* (PAHO/WHO 2006).

Communication Part 1: Infodemics and misinformation

By Christopher Burke

The importance of communication can never be overestimated. The capacity for effective two-way communication is critical to driving the discourse of any mission and shaping its public perception. The dissemination of accurate and timely information will minimise information vacuums that can be exploited and result in negative coverage. Before messages are crafted, it is crucial to ascertain the situation accurately as well as to understand stakeholder and public perceptions.

Crisis management missions will typically face an overload of information – a phenomenon referred to as ‘infodemics’. Sources of information comprise everything from traditional media (print, TV and radio) to rapidly emerging digital media (social media and emails) and word of mouth. Time and resource constraints rarely permit the opportunity to watch, read and listen to everything. A systematic strategy is required to identify and understand pertinent issues, before meaningful responses can be developed and disseminated.

Sources

The main categories of information are:

- primary data, such as government or key stakeholder announcements;
- secondary sources, including traditional and digital media;
- informal sources, such as staff and casual encounters with members of the public.

The availability of print media and TV are often minimal in a crisis scenario. FM radio, ubiquitous in most parts of the world, is an extremely effective tool for public communication. But it is heavily influenced by local political conditions and is limited geographically to not more than 30km beyond direct line of sight from a transmitter or repeater. Short-wave radio is a more reliable medium for objective information from global news agencies, but it is rarely detailed, often outdated and will not provide a nuanced understanding of the situation. A small battery-operated SW/FM radio is an invaluable addition to any relief worker's go-bag.

Digital media are an increasingly important source of information, though often not feasible in crisis situations due to damaged infrastructure. While internet penetration and access to smart phones are growing rapidly, according to the World Bank 'only about 35 percent of the population in developing countries has access to the Internet (versus

about 80 percent in advanced economies).’ Word of mouth continues to be very effective. It can be astonishingly fast and uncannily durable, but it is also vulnerable to distortion and misinformation.

Misinterpretation and misinformation

Each of these sources must be assessed and contextualised against prevalent, prominent social, political and economic factors. The facts and figures received will often be inconsistent and sometimes conflicting. Most errors and contradictions can be attributed to shortcomings in the capacity of information sources, associated with misinterpretations, typos and delays between the capture and dissemination of information.

However, sometimes the errors can be more insidious. Deliberate misinformation can be as simple as withholding key facts and figures in the development and dissemination of information. Information can be intentionally manipulated. Misinformation, while most common in conflict scenarios, is prevalent in many crises. Unscrupulous actors at any level of civil society or government can exploit situations for economic, social or political gain – especially in emergency situations, where positions and power can change hands very rapidly. Response missions are often key actors and risk being co-opted to legitimise false or misleading information to support the cause of unscrupulous actors. Even percep-

tions of partiality can leave mission staff and beneficiaries vulnerable to attack or marginalisation.

Failure to accurately assess information can result in an incorrect analysis of a situation. This will at best undermine the mission, wasting time and resources, while at worst it can expose mission staff and beneficiaries to unnecessary danger. For example, you might unknowingly move through an area still exposed to risk from landmines, or establish operations somewhere prone to floods or landslides. Meanwhile, internal divisions within your own mission may result in distortions in the management of information that can adversely affect operations.

Managing your mission's communication

All information, irrespective of the source, must be scrutinised objectively for both misinformation and the omission of key facts. Information must be weighed and contextualised against relevant trends. Patterns will quickly emerge, but facts should be cross-referenced against as many different sources as possible (primary, secondary and informal), across the social, political and economic spectrum before being treated as credible.

Once fully cognisant of the relevant issues, including the positions of different stakeholders, the mission's messaging and content can be tailored to the appropriate media (print, TV, FM radio and digital) targeting specific audiences. Mis-

sion staff should be fully briefed on the content of official communications. They will play an important role in the dissemination of information via word of mouth among beneficiaries and within the community. The impact of all communications should be carefully monitored and assessed, to fine tune the development of content and reassess the efficacy of the different media used for dissemination. Communication among mission staff requires constant management and coordination.

Communication Part 2: Guiding principles of community engagement and risk communication

By Heide Weishaar and Almudena Mari-Sáez

Community engagement and risk communication are key pillars of health emergency response and fundamental for the successful implementation of response measures. Given that deployed personnel often closely interact and work with members of communities at risk, it makes sense that they familiarise themselves with the guiding principles and basic recommendations for communicating risk and engaging communities during public health emergencies.

Community engagement

Community engagement is fundamental before and during the response to health emergencies. When carried out effectively, community engagement can help in the prevention and control of an outbreak threatening public health, and provide people with crucial knowledge to allow them to reduce risks and protect their lives.

Every health emergency will happen in a unique social context, with its own specific history, economy and belief systems. This context will shape local perceptions of events and of the response to the emergency. Responders will therefore need to gain an understanding of these local

perceptions to facilitate community engagement and ensure that those affected by the outbreak are part of developing and implementing the response. As is good practice with any intervention, communities should be considered part of the response, not part of the problem.

Responders should engage with affected communities early in the response to a health emergency. It should be a two-way process, through which both sides get to know each other better. There should be a 'trust-building pathway', including open communication channels with communities and encouraging their active participation in decision-making.

Only by engaging with communities will responders gain an understanding of which stakeholders to involve, for example who is influential and who is vulnerable. By identifying existing social structures, the response can be built upon active, trustworthy actors and social networks. They will facilitate the identification of needs and appropriate solutions. The trust and participation that this communication builds within the community will also assist in their acceptance of emergency response measures.

When reliable social networks are unknown or inaccessible, community engagement should aim at being as inclusive as possible, in terms of age, gender, language skills, residence and other relevant factors. Responders should build the capacity of locals to identify needs and to plan, implement

and evaluate actions to prevent and protect people's health during emergencies.

Community engagement should be a flexible and adaptive process, as a community's needs and actions can change as the response to the emergency evolves. This could also mean that fewer human and financial resources are needed (or are available), so an evaluation and exit plan should be put in place.

Community engagement can be harder when populations are required to self-isolate or mass-quarantine. In these situations, social media, live radio programmes or individual phone calls may be more effective communication tools. It will be important to know which channels are used and accepted locally and to reach out to affected people accordingly.

Risk communication

Risk communication is the real-time exchange of information, advice and opinions between experts, community leaders or officials and people who are at risk. It needs to be an integral part of any emergency response. WHO has developed recommendations on risk communication that provide overarching, evidence-based guidance on how risks should be communicated in an emergency (see Box).

During public health crises, people need to understand the health risks they face and the actions they can take to protect

their health. Responders must provide accurate information in a timely manner, in languages that people understand and through channels they trust and use. It is important to identify relevant information channels early on in the mission, including social media, so as to communicate effectively and to be able to respond swiftly to any false information and rumours. That way, affected people can make choices and take actions to protect themselves, their families and communities.

Risk communication should be harmonised with other aspects of the emergency response, for example, monitoring of health risks, interventions to reduce health hazards, and evaluations of the response. Informing the public about these actions is important to build trust and improve transparency. It is important to understand that risk communication is a two-way process, shaped by the beliefs, concerns, needs and reactions of people at risk.

WHO recommendations for communicating risk in public health emergencies

1. Building trust and engaging with affected populations

Establishing and maintaining trust is arguably the first and most important step in effective emergency risk communication. Building trust is closely linked to community engagement and open acknowledgment of uncertainty.

2. Integrating emergency risk communication into health and emergency response systems

Risk communication has to be integrated into health systems and be consistent with other parts of the emergency response. Risk communication should have a designated strategic role and defined budget in emergency response, involve relevant local stakeholders, and form part of capacity building of personnel.

3. Emergency risk communication practice

Best practice for risk communication includes strategic planning, continuous assessment and rapid evaluation of interventions, use of social media and peer-to-peer communication, and a careful tailoring of messages.

Source: WHO, see Credits and References

Communication Part 3: Information management and visualisation

By Matt Sims and Alan Mills

Throughout any emergency response there is a need for information and a clear understanding of the situation, so that responders can make well-informed decisions. Data, visualisations and information management are vital to this.

In addition to information on the current situation, you need pre-event data as a baseline against which to compare recent changes. Understanding what you don't know is as important as understanding what you do know. Identifying information gaps may help highlight people in need of assistance who had been overlooked.

Information areas and product formats

In the initial phases of a response, the focus will be on immediate risk to life. As the response develops, it is important to understand the following:

- the determinants of health – the population's vulnerability before the incident;
- the health system – the national healthcare delivery system, its operational status and capacity post-event;

- profiles of morbidity and mortality – any endemic and emerging diseases (existing and recently appearing diseases), both communicable and non-communicable;
- emergency medical teams – any surge capacity being provided to the healthcare system.

To decide on the format of the information product, you need to understand who will use it and how. Product formats include:

- static maps – field workers prefer paper maps to write and draw on, while headquarters like maps they can use in reports and presentations (see Figure 3.1);
- temporal visualisation – this product uses a series of maps or graphs to show trends over time, presented on a single page or as an atlas;
- dashboards and other online tools – these are more dynamic and interactive, and allow the user to explore the information for themselves;
- graphs and other visuals – if there is a spatial element then a map is probably the best format; however, a graph showing trends, a simple table, a word cloud or another visual might be more appropriate.



Liberia: Ebola

Location and status of Ebola Response Units (as of 8 Oct 2014)

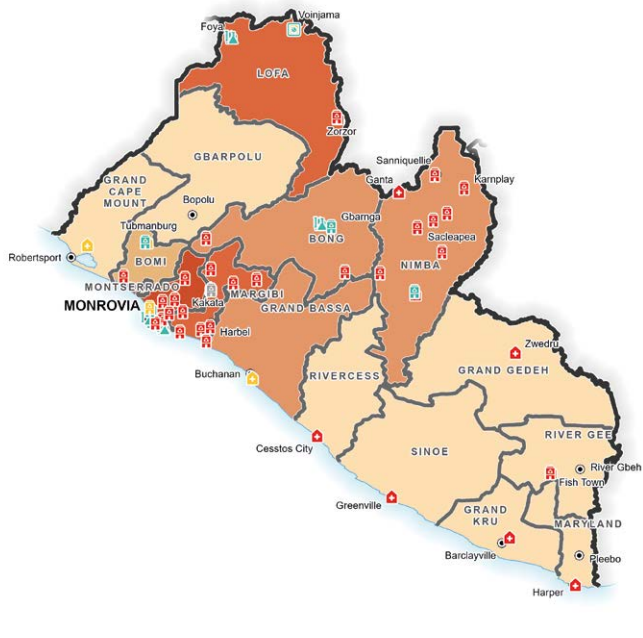





Figure 3.1 Liberia: Ebola outbreak
Source: MapAction, 2014

Ebola Response Units





Type

-  Community Care Centre
-  Ebola Treatment Unit
-  Laboratory
-  Triage

Status

-  Open
-  Planned
-  Under Construction
-  Unknown

Cumulative cases

-  ≤1,748
-  ≤1,000
-  ≤500
-  ≤100
-  1-50

Settlements

-  Capital
-  City

Borders

-  INTERNATIONAL
-  COUNTIES

Data sources: MoHSW, DoD, LISGIS, NGA
 Map created by MapAction (08/10/2014)

Information management considerations

An organisation can be ready to respond more quickly and efficiently by having a good information management system in place, including a folder structure and a data-naming convention for organising documents and data.

When you receive data, there are a number of checks that you may wish to include. These can easily be remembered using the acronym CUSTARD.

The CUSTARD check

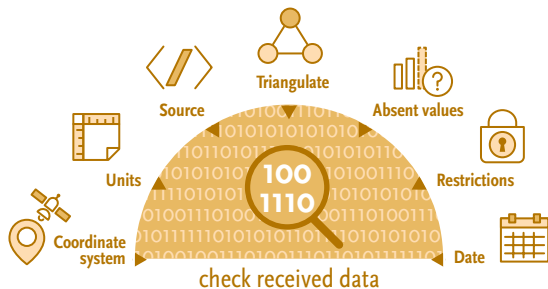

Coordinate system – if coordinates are provided, find out what form they take. Are they decimal degrees (DD, e.g. -1.283333, 36.816667), degrees minutes seconds (DMS, e.g. 1° 17' 0" S, 36° 49' 0" E), or something else?

Units – what is the unit measure, e.g. litres, metres, an individual, a household (how big is a household?). Are the case numbers being reported using Epi weeks? If they are, make sure to use this in your reports.

Source – from whom and where has the data come? Is the source trusted? Do you have contact details for further questions or more data?

Triangulate – examine the data and ask, 'does it look right?'. Compare it with other data you may have and see if it makes sense. If it doesn't, then ask the source more questions.

Absent values – look for any absent values and check what an 'empty cell' means. Is it meant to be empty, or is data missing? You will need to represent this information clearly.

Restrictions – how can you use the data, what are the limitations, do you need a licence?

Date – when was the data collected or produced? This gives an indication of currency and potential accuracy.

Health-related information is highly temporal and dynamic in its nature, and it is important to convey this in any visualisation. Look to show changes and trends in the data. For example: are case numbers increasing or decreasing, rapidly or slowly? Are there patterns and trends?

Data protection and quality control

The nature of your data in a health response and the specific level of detail will vary, depending on who you are working with and what you are working on. You should consider whether there is any sensitivity on using or publishing the data. This is particularly important in relation to individuals or vulnerable groups, where poor data handling or neglect may result in their being exposed to a threat, stigma or isolation.

You should consider the questions below when handling such information.

- Does this data identify and pinpoint the locations of vulnerable individuals or groups?
- Is the data indispensable for me to do my work?
- How am I storing and protecting the data?
- What will I be producing from the data?
- Will I be sharing the data internally within my organisation, or with a trusted wider group, or publicly?

By answering these questions, you can determine how to mitigate the effects of any data protection lapses. Some techniques involve stripping out sufficient personal information from released data (anonymising) to make it difficult to identify individuals or groups. Another technique is to aggregate your data into larger areas or datasets, so that people cannot be identified or located.

Thoughtful quality assurance (QA) and quality control (QC) ensure that information products reach the highest standards and communicate the intended message in the best way. Quality assurance is a proactive process that defines standards, procedures and templates before the product is created. Quality control is a reactive process that tests the product against those standards (see Fig. 3.3).

Quality Assurance and Control





	Quality Assurance	Quality Control
 Standard operating procedures	<ul style="list-style-type: none"> - Setting standards - Setting procedures 	<ul style="list-style-type: none"> - Test the outputs against the standards and procedures
 Medium	<ul style="list-style-type: none"> - Creating templates - Have agreed symbols - Define common terminology 	<ul style="list-style-type: none"> - Check the format
 Message	<ul style="list-style-type: none"> - Understand the end user requirements - Understand the question you are trying to answer 	<ul style="list-style-type: none"> - Ensure the output sends an effective, beneficial and useful message
 Skills	<ul style="list-style-type: none"> - Data handling - Have a good understanding of visualisation - Set best practice 	<ul style="list-style-type: none"> - In seeing both the wider picture (client perspective) and having an eye for detail
 Product	<p>Product producer</p> <ul style="list-style-type: none"> - Awareness that there are quality assurance standards before they start work 	<p>Product reviewer</p> <ul style="list-style-type: none"> - Have someone review the product against the QA standards without too much subjectivity

Figure 3.3 Quality Assurance and Control
Source: MapAction, 2020

Digitalisation of health and health responses

By Sandra Beermann and Patrick Schmich

In critical times, digital solutions play a vital role for epidemiologists and public health practitioners involved in the development and implementation of surveillance systems for infectious diseases and environmental hazards, and in assessing the most appropriate interventions for dealing with disease outbreaks and pandemics. The COVID-19 crisis demonstrated the potential of digital health technology to manage some of our greatest public health challenges. From drones repurposed for public health messaging to symptom checkers and track and trace apps, a range of solutions helped tackle the challenges posed by the pandemic. Mobile applications in particular have the potential to improve public health surveillance by bolstering contact-tracing strategies to contain and reverse the spread of pandemics. Besides smartphone apps, features such as geolocation (via GPS) and social media entries may allow, under certain conditions, for better monitoring and tracking of situations in real time and enable faster responses in the right locations, including the notification of at-risk individuals.

As data-driven solutions become more common and present new ethical challenges, it is increasingly important to communicate the purpose, objectives and direction of digitalisation in public health. Artificial Intelligence (AI) occupies a central role, owing to the application of Machine

Learning. A continuous debate on emerging ethical issues, coupled with periodic revision of available evidence, relevant guidelines and policies, is needed. However, digital health should contribute to values-based health systems and not change long-held public health goals and values. It should be well planned, coordinated and governed at national and international levels.

Another issue is the interoperability of technical solutions. Interoperability is the ability of different information systems, devices and applications (systems) to access, exchange, integrate and cooperatively use data in a coordinated manner, within and across organisational, regional and national boundaries. There are worldwide efforts to analyse and implement greater interoperability, but coordination of this remains difficult. This should always be taken into account during missions.

Examples of digital health tools

Below are some examples of digital health tools useful in the monitoring of disease outbreaks in emergency settings.

EWARS

WHO's Early Warning, Alert and Response System (EWARS) is designed to improve disease outbreak detection in emergency settings, such as in countries in conflict or following a natural disaster. EWARS is deployed during an emergency as an adjunct to the national disease surveillance system. The 'EWARS in a box' contains all the equipment needed to establish surveillance and response activities. WHO works with ministries of health and health sector partners to train local health workers to use the system. After the emergency, EWARS should reintegrate back into the national system.

Go.Data

Go.Data is an outbreak investigation tool for field data collection during public health emergencies from WHO/GOARN (Global Outbreak Alert and Response Network). The tool includes functionality for case investigation, contact follow-up, visualisation of chains of transmission including secure data exchange and is designed for flexibility in the field, to adapt to the wide range of outbreak scenarios.

SORMAS

The Surveillance Outbreak Response Management and Analysis System (SORMAS) is an open source mobile e-health system that processes disease control and outbreak management procedures in addition to surveillance and early detection of outbreaks through real-time digital surveillance, including peripheral healthcare facilities and laboratories.

DHIS2

District Health Information Software 2 (DHIS2) is an open source, web-based health management information system (HMIS) platform. The DHIS2 platform boasts data warehousing, visualisation features, and the possibility for data users and policy makers to generate analyses from live data in real time. In collaboration with experts in the DHIS2 community, ministries of health can configure their own information system on top of the generic platform.

Coronavirus tracing apps

At the time of writing, the list of countries that were developing or that had released coronavirus tracing apps was extensive and, according to tracking by the MIT Technology Review, close to 50 governments were implementing them. Even though tracing apps have shown promise, they are highly controversial due to privacy concerns. The extent to which the apps collect user data varies considerably by country.

On a mission

Before a mission, you should inquire about the general terms and conditions of the mission. These guidelines should also contain information on how to handle data collected during a mission. For example, national data protection laws must be observed with regard to the collection and further use of data. The owner of the data is clearly the country or national institutions. Therefore, all analysis of data outside the country, scientific papers, articles, publications or abstracts should only be published after agreement and clearance through established mechanisms of the mission country.

There is a further provision for the laboratory sector, which should be observed when working in a partner country. The Nagoya Protocol on Access to Genetic Resources and the Fair and Equitable Sharing of Benefits Arising from their Utilization to the Convention on Biological Diversity is an international agreement which aims at sharing the benefits arising from the utilisation of genetic resources in a fair and equitable way.

On mission it is important to deal with the different systems onsite. Even though improvements to the existing systems may be desirable, it is important to avoid excessive modifications at the beginning of a mission, as this can lead to considerable tensions with colleagues in the target country. An insight into the structure and history of technical development is usually only gained after some time in the field.

Environmental risks and climate extremes

By Luzie Verbeek

Anthropogenic climate change is the defining challenge of the 21st century. The change in the frequency and intensity of extreme weather events may be one of the reasons for your mission. Extreme weather is not only presenting new challenges for crisis management, it may threaten the success of your intervention.

Rising temperatures drive extreme weather events

The five-year period from 2015 to 2019 was the warmest of any equivalent period on record, with a 1.1 °C global temperature increase above pre-industrial levels, according to the World Meteorological Organization (WMO). Driven by accelerating concentrations of atmospheric CO₂, rising temperatures are melting sea ice in the Arctic and Antarctic as well as glaciers in Greenland and across the world. This melting, along with thermal expansion from warmer oceans, is pushing sea levels higher. Precipitation has increased in some regions and decreased in others.

Over the period, tropical cyclones caused the largest economic losses, but heatwaves were the deadliest meteorological hazard. This drove up local temperatures to record highs, accompanied by droughts in Africa and unprecedented

wildfires in Europe, North America, Australia, the Amazon rainforest and the Arctic.

The local effects of climate-related changes can differ greatly. Risks to society include impacts on food (e.g. crops, fisheries, livestock), water security, livelihoods, biodiversity, economies, infrastructure, emerging and re-emerging diseases, and thus on health. 'Climate-related risks associated with climate variability and change exacerbated food insecurity in many places, in particular Africa, due to the impact of drought, which increased the overall risk of climate-related illness or death', stated the WMO in its publication *The Global Climate in 2015-2019*.

Health impacts of extreme weather

The health impacts of rising temperatures and extreme weather events can be categorised in three different pathways: direct exposure, indirect exposure, and economic and social disruption.

Heat stress is an example of direct exposure, affecting vulnerable groups such as the elderly, small children, pregnant women and outdoor workers. Underlying health conditions, including chronic disease, are worsened. Variability in temperatures makes adaptation more difficult. Heat also increases the probability of accidents, reduces work productivity and affects air quality. On the positive side, there

might be modest reductions in cold-related mortality and morbidity in some areas.

Indirect impacts can arise from the effects of extreme temperatures on environmental conditions, such as changes to geography, baseline weather, air and water quality, soil and dust, and vegetation. The prevalence of mosquitos, ticks and other vectors is sensitive to climatic factors and is spreading in many regions, causing a rise in malaria, dengue infections, tick-borne diseases and plague. However, the influence of temperature and other climatic effects on vector-borne diseases is complex and non-linear. Food-borne and water-borne diseases can be exacerbated due to warmer conditions, flooding, precipitation and an increase of exposure to climate-sensitive pathogens.

Meanwhile, impacts on food production and distribution pose a risk to economies and societies. Resource shortages and changing environmental conditions (e.g. coastal inundation, salination of cropland, drought conditions, wildfires and windstorms) due to climate effects can cause further inequity, conflict and the displacement or migration of populations.

Dealing with climate extremes

- Use early warning systems for extreme weather events and stay informed on how to protect yourself and others.
- Be prepared for the ‘new normal’ and expect the unexpected. Floods, windstorms, heatwaves or wildfires may occur in previously unaffected places.
- Consider climate risk and the long-term co-benefits that adaptation and mitigation measures by your mission could bring for your beneficiaries.

Adaptation and mitigation

Adaptation to climate change is more difficult for low- and middle-income countries, especially for small island developing states. However, developed countries are also vulnerable if critical infrastructure is affected (e.g. power outages) or if sufficient adaptation measures are not in place (e.g. lack of cooling centres, failure of cold chain for medical supplies during heatwaves). The goal of adaptation is to increase the resilience of communities to extreme climate effects. It includes strengthening health systems, primary healthcare, early warning systems, disease monitoring and surveillance. Climate risk needs to be a part of development and risk reduction planning and, whenever possible, in short-term emergency missions too.

Mitigation is the term for the reduction of greenhouse gas emissions, used by the Intergovernmental Panel on Climate Change (IPCC). The co-benefits of mitigation refer to the reduction in atmospheric concentrations of climate-altering pollutants along with the possible associated positive effects on human health. These co-benefits of mitigation include an increase in urban green spaces, active transport in urban areas, decreases in meat consumption, and a reduction in health-damaging pollutants through changes in energy production and efficiency (e.g. alternatives to household solid fuel combustion).

The aim of the 2015 Paris Agreement on climate change is to hold the rise in global average atmospheric temperature to less than 2°C above pre-industrial levels – and if possible less than 1.5°C. Temperature increases above 2°C would result in future hydrometeorological hazards of an intensity and frequency surpassing previous experience.

Adapting to climate change requires systemic risk management. Frameworks such as the Sendai Framework for Disaster and Risk Reduction 2015-2030, and the UN 2030 Agenda for Sustainable Development, with the associated Sustainable Development Goals, are important tools for the global development agenda to ensure humankind remains on a manageable trajectory.

Environmental health in emergencies

By James Brown

The condition of the environment, both natural and built, has a significant impact on health and well-being. WHO estimates that almost 1 in 4 deaths are attributable to environmental factors globally (12.6 million deaths annually – WHO, 2015).

Humanitarian crises can have a devastating impact on the environments where people live. Whether people have been displaced into temporary, makeshift settlements or whether they remain in place, the most visible impact of natural disasters, conflict and other complex emergencies is often environmental degradation. High population densities combined with inadequate or inappropriate sanitation, water supply or waste management can make it difficult for people to practice safe hygiene and create the ideal conditions for disease transmission. Environmental health interventions aim to address these risks through both ‘hardware’ (engineering) and ‘software’ (hygiene promotion) approaches.

The WASH sector

Although environmental health encompasses a wide range of factors including housing, air quality and pollution, radiation, noise and occupational risks, in emergency settings humanitarian interventions prioritise risks related to environmental sanitation (excreta, solid waste, medical waste

and wastewater), water supply, and personal and domestic hygiene. Collectively, these interventions fall under the water, sanitation and hygiene (WASH) sector, with specialists using a combination of engineering, behaviour change, community engagement and market-based programming to mitigate and control disease risk. Humanitarian WASH response will usually be coordinated by a national WASH cluster, while the Global WASH Cluster provides coordination support and represents the sector at the international level. For more information on the cluster approach, refer to Chapter 1.

Key environmental diseases

Causes of disease associated with environmental conditions include: insect vectors such as malaria (mosquitoes breeding in stagnant water) and Leishmaniasis (sand flies breeding in wall cracks and crevices); faecal-oral transmission causing diarrhoea (e.g. Cholera, Rotavirus, Amoebic Dysentery) or enteric fevers (e.g. Typhoid, Hepatitis A, Poliomyelitis); and water-based pathogens, both biological (e.g. Guinea worm, Schistosomiasis) and chemical (e.g. arsenic, agricultural or industrial chemicals). Poor WASH conditions can also contribute to cases of diarrhoea, intestinal worms and environmental enteric dysfunction, which can all limit the absorption of nutrients and decrease the body's immunity, meaning that there is an association between environmental health and undernutrition, especially in children.

Faecal-oral transmission

Diarrhoeal disease is the second leading cause of death in children under five years old, killing around 525,000 children every year, according to WHO. In 2016, diarrhoea was responsible for 74 million disability-adjusted life years (DALYs), of which 40 million occurred among children under five. It is estimated that almost 60% of all diarrhoeal disease in low- and middle-income countries (LMICs) could be reduced by controlling environmental risk factors. While significant progress has been made in LMICs to improve environmental health through WASH interventions, humanitarian crises can quickly reverse these gains.

Faecal-oral transmission of diarrhoeal diseases

Barriers can stop the transmission of disease; these can be **primary** (preventing the initial contact with the faeces) or **secondary** (preventing it being ingested by a new person). They can be controlled by **water (W)**, **sanitation (S)** and **hygiene (H)** interventions.

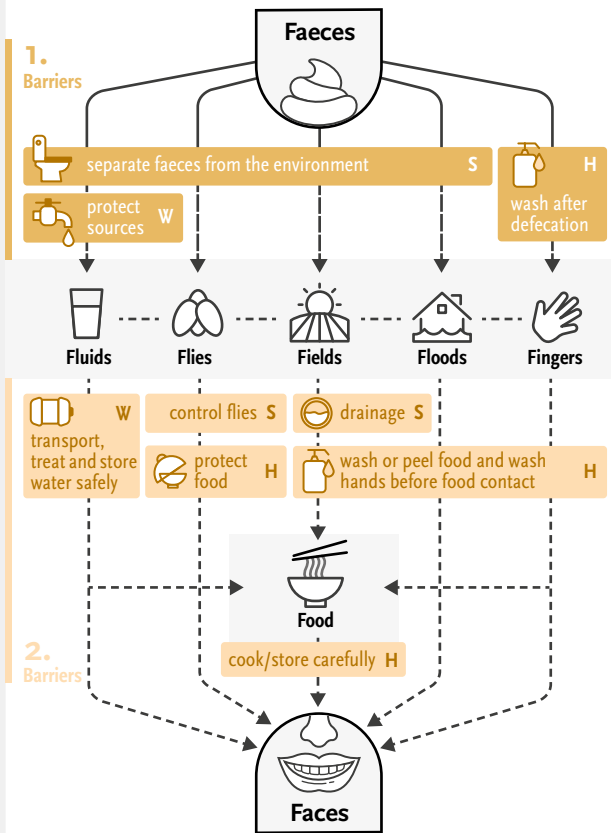

The F-diagram illustrates the main pathways for faecal-oral disease transmission, and the barriers to transmission that WASH interventions aim to put in place (see Figure 3.4). The most important transmission route will depend on contextual factors such as behaviours, infrastructure and type of pathogen, but common barriers should be implemented in any programme. These include:

- environmental sanitation to prevent faecal contamination of the environment;
- water supply, treatment and safe storage to enable good hygiene practices and ensure water is safe to drink;
- hygiene promotion, to support hand washing, food and water safety and appropriate health-seeking behaviour.

WASH and environmental health

WASH programmes predominantly address environmental factors at the community, household or individual level, through construction, operation and maintenance, distribution of supplies and hygiene promotion. However, WASH specialists may also work in schools, healthcare facilities, public buildings and other institutions. WASH services in schools can promote school attendance, especially where girls' access to education is limited by inadequate support for menstrual hygiene. In healthcare facilities, water supplies and hygiene behaviours are crucial components of infection prevention and control. WASH specialists can also provide facilities for the management of medical

Figure 3.4 The F-diagram: faecal-oral transmission of diarrhoeal diseases
Source: Adapted from 'F-diagram' (WEDC, Loughborough University)

waste. During outbreaks of infectious disease, WASH teams can play a significant role in supporting both clinical and community infection prevention and control measures, as well as promoting preventative measures and health seeking behaviour.

Water supply

Water supply systems must consider both the quality and quantity of water available, as well as accessibility. The distance from the home to the water point is often the biggest factor in determining household consumption, as people who are unable to collect sufficient water from a treated source to meet their needs may resort to using unsafe alternatives. Hygiene messaging is required to let people know which water sources are treated and to promote safe collection, transport, treatment and storage of water.

Common water treatment methods include sedimentation and filtration to remove particulates, followed by treatment with chlorine to inactivate pathogens. Chlorination is dosed to produce a level of free chlorine that provides some residual protection against contamination during transport and storage, although this will decay over time.

Environmental sanitation

Toilets must be able to effectively separate and contain excreta, they are the primary barrier to faecal-oral transmis-

sion. They are also a sensitive and personal intervention area that must be adapted to the practices and preferences of users. Facilities that are dirty, full or damaged are unlikely to be used and can contribute to health risks, so cleaning and maintenance of toilets must be considered from the outset. Sanitation is a service, not a one-off installation and interventions need to plan for managing faecal sludge to prevent contaminating ground water and the wider environment.

Hygiene promotion

The promotion of healthy behaviours is fundamental to any WASH response. Providing toilets, clean water supply and hygiene materials can only be effective as long as they are used safely and consistently. Effective hygiene promotion is an evolving field, with more sophisticated approaches being adapted from anthropological and behavioural techniques, based on participatory and community engagement methods that build trust through dialogue.

Standardised messages and one-way dissemination channels such as hygiene teaching sessions should be complemented with approaches that are specific to the context and affected population. Health risks and the perception of risk can differ significantly between contexts. Life experience, culture and beliefs, preferences and behavioural norms can all influence behaviours and must all be considered while designing behaviour change methods.

Because hygiene promotion teams work closely with affected communities, they often become focal points for community feedback and complaints. The understanding that hygiene promoters develop of the specific needs, fears, preferences and practices of different groups can be invaluable in designing and adapting interventions to be both appropriate and effective.

Beyond health

WASH tackles not only issues of health, but also of bodily safety and dignity. Everyone has the right to water and sanitation, and WASH services are an important component in the right to life with dignity, the right to protection and security, and the right to receive humanitarian assistance on the basis of need. However, using toilets, bathing facilities and water points can be dangerous, especially for women and girls. Leaving shelters to use toilets at night or leaving the settlement to collect water can expose people to the risk of gender-based violence. WASH specialists must consult men, women and children to understand how they perceive risks and to design ways to address these risks through the required interventions. Common ways to address fears include providing facilities that are shared by a few households rather than communally, designing toilets and bathing shelters to ensure privacy, and providing adequate lighting.

WASH interventions must be designed to be accessible for men and women at different life stages, who may have particular needs because of illness or disability. This includes ensuring that women and girls can manage their menstruation comfortably and safely, and that people with limited mobility or incontinence are able to access appropriate toilets and spaces for bathing. While WASH facilities can be adapted to be more easily accessible, some people may need specific toilet and bathing options that can be used inside the home.

Epidemiology

By Tim Eckmanns

Epidemiology is the study of the frequency, distribution, control and risk factors of health-related states and events in a population, as well as their associations and causal relationships. These can be studied in different populations, and at local, national and global levels. Infectious diseases were previously responsible for much of the burden of disease, but non-communicable diseases (NCDs) are now rising in most regions of the world. Infectious diseases and NCDs, such as poisoning, are of concern in health emergencies.

Epidemiology is about data. Defining time, place and affected person/population is key. An example of a clear epidemiological phrase is that in 2018, the under-five mortality rate in Pakistan was 70, which means 70 children died per 1,000 live births.

Descriptive epidemiology identifies the pattern of disease occurrence and generates hypotheses. In analytical epidemiology, hypotheses are tested through different study types. In observational studies – such as cross-sectional studies, case-control studies and cohort studies – there are no interventions. For example, in a cohort study, the natural course of a disease is observed and a relationship can be assessed by comparing risk factors and outcomes among the population of interest. In experimental or intervention

studies, the effect of a treatment or preventative method on a health-related state is assessed. An example of this is a placebo-controlled trial, where one group of participants may receive a new drug whereas the other group receives a placebo.

Surveillance is central to epidemiology. It is the continuous and systematic process of the collection, analysis, interpretation and dissemination of descriptive information, to monitor and address health problems. This includes feedback of results to those who provided the data and to those who can support decision-making and action – a process known as data for action. The main objectives of surveillance, particularly the surveillance of infectious diseases and health emergencies, are to monitor trends and detect disease outbreaks. Different situations require different kinds of surveillance. Single, clearly defined infectious diseases, such as measles, require case- or indicator-based surveillance. Conditions such as diarrhoea require syndromic surveillance. Any aspects or indications of a current or potentially emerging outbreak require event-based surveillance.

A range of tools is available for collecting and reporting data, from paper-based systems to fully automated systems using technology such as smartphones or tablets.

An example of surveillance in practice is the surveillance of measles in a refugee camp. An easy case definition could be selected, such as fever *and* maculopapular rash (i.e. non-vesicular rash) *as well as* cough or coryza (runny nose)

or conjunctivitis (red eyes). All cases would need to be identified and information collected on gender, age and vaccination status for every case. Age-specific attack rates (number of cases in all persons of a specific age group) could be calculated if the gender and age distribution in the camp are known.

Statistical models are a useful method for analysing epidemiological data. They rely on assumptions and are a simplification of reality to help understand the structure or mechanism of the epidemiological situation. There are many different models. The simplest and most frequently used in infectious disease epidemiology is the susceptible-infectious-recovered (SIR) model. It provides an understanding of how many people are infected, how many are susceptible and how many have recovered and are no longer susceptible. More sophisticated models, such as agent-based models (ABM), are used to simulate pandemics, for example. These simulations use a variety of parameters to produce a series of present futures and to map a range of possible scenarios. While models can help in making informed decisions, it is important to remember their limitations, due to the different assumptions on which they are based and the simplification that is inherent in every model.

Evidence-based approaches are another important component of epidemiology. Epidemiological studies should be well-conducted and of high quality to assess the effect of interventions and contribute to the body of evidence. The

best-available evidence can then inform decisions and ensure effective and equitable public health interventions across the world.

Epidemiological surveillance

By Jan Walter and Ariane Halm

Epidemiological surveillance is often defined as the ongoing systematic collection, analysis, evaluation and dissemination of health data for the purposes of planning, implementing and evaluating disease control measures. While a key focus for surveillance in humanitarian crises is to control the spread of infectious diseases, it can also be applied to non-communicable conditions, for example the surveillance of injuries, malnutrition, mortality and many more.

Surveillance is an essential feature of epidemiological practice and may be used to:

- describe the affected population;
- facilitate early detection of epidemics;
- recognise isolated or clustered cases;
- assess the public health impact of events and assess trends;
- generate hypotheses for studying the risk factors of disease;

- monitor the effectiveness and evaluate the impact of prevention and control measures, intervention strategies and health policy changes;
- plan and provide measures, intervention and care.

In addition to estimating the magnitude of infectious diseases in the population and monitoring their trends, surveillance data can also be used to:

- strengthen commitment;
- perform information, education and communication activities;
- mobilise communities;
- advocate for sufficient resources.

There are different ways to implement surveillance systems. They can be categorised into:

- active surveillance systems, where information is actively acquired, e.g. by staff calling health practitioners;
- passive surveillance systems, such as the mandatory reporting of certain laboratory diagnoses.

These systems may encompass the comprehensive surveillance of all events in a certain place and time period, or they may be based on a selection of participants (e.g. a sentinel system covering only selected laboratories).

Traditional surveillance is indicator-based, using a defined set of conditions to be met for a reportable disease or other health-related condition. For surveillance of specific diseases this often includes laboratory-confirmed diagnosis. Sometimes characteristic clinical signs together with external information may be sufficient (e.g. watery diarrhea during an outbreak of cholera in the same community) or the surveillance may be based on a combination of clinical symptoms (e.g. influenza-like illness or acute gastroenteritis, for the rapid detection of outbreaks). The latter is also referred to as syndromic surveillance.

In contrast to indicator-based surveillance, surveillance can also be event-based, defined by the US Centers for Disease Control and Prevention as ‘the organized collection, monitoring, assessment and interpretation of mainly unstructured ad hoc information regarding health events or risks, which may represent an acute risk to health.’

Depending on their objectives, surveillance systems can be designed to fulfill specific criteria, such as simplicity, flexibility, acceptability, sensitivity, predictive value positive, representativeness, timeliness, data quality and stability. It is important that these objectives are explained clearly to those respondents being asked for data. Consistent feedback in the form of surveillance reports can contribute to this objective. Regular evaluation of the surveillance system is recommended.

As with any collecting of human health data, surveillance systems need to follow the ethical principles governing medical research and should ensure that personal data is protected. Often, different countries have their own specific laws regulating health surveillance and these need to be observed.

WHO has published some relevant guidelines for the implementation of a surveillance system, including the following:

- *Technical Guidelines for Integrated Disease Surveillance and Response in the WHO African Region: Third edition, 2019;*
- *Outbreak surveillance and response in humanitarian emergencies, WHO guidelines for EWARN implementation, 2012.*

Healthcare in fragile settings

By Samuel T. Boland

A fragile setting is when overlapping and interconnected challenges risk overwhelming communities' resilience and the provision of routine services to them. It is broader than, but akin to a complex emergency – defined by WHO as a major humanitarian crisis that is 'the result of warfare, civil disturbance, and large-scale movements of people, in which any emergency response has to be conducted in a difficult political and security environment'. Some entire countries are considered fragile, while some otherwise stable countries might have regions or areas of fragility.

The healthcare needs and gaps in these contexts are extreme, especially when the compounding effect of multiple challenges results in the collapse of health systems and, subsequently, the inability to provide routine health services to already vulnerable populations. These healthcare needs and gaps are hard to overstate. It is estimated that 60% of preventable maternal deaths, 53% of under-five deaths and 45% of neo-natal deaths take place in settings of conflict, displacement and natural disasters, according to WHO.

Due to the scale of needs and gaps and the complexity of providing services in fragile settings and complex environments, a variety of actors may provide some degree of health service, including public, private, military and non-governmental groups. This provision can be especially

diverse in areas of conflict where territory and control are not stable or clearly defined, and where some actors are not able to operate consistently across a particular geography. Often in such settings, the UN Office for the Coordination of Humanitarian Affairs (OCHA) will establish the cluster approach to coordinate the variety of necessary humanitarian activities, in which WHO is lead agency for health. There is often a non-governmental organisation health forum that sits within the health cluster to coordinate the health services provided by non-governmental actors.

Affected populations are often highly diverse in fragile settings and complex environments, not only in their demographics but also in the needs that they face. Fragile settings and complex emergencies do not affect all people equally. The NGO Plan International estimates that women and children are up to 14 times more likely than men to die in a disaster. Addressing a population's healthcare needs should account for and adjust to these discrepancies.

In such contexts, further consideration should be given to understanding and addressing negative health-seeking behaviours, service utilisation (especially when health-seeking tendencies are poor due to the lack of safe or available services), and health system and community resilience, all of which may be highly dynamic in the face of ongoing threats and risks.

Health practices and quality of health care

By Thomas Cotter and Vlatko Uzevski

Internationally deployed clinicians are expected to provide patient care and clinical environments based on widely accepted international standards, regardless of country of origin. The WHO Emergency Medical Teams' (EMT) *Blue Book* outlines best practices for clinical operations and quality patient-care practices.

EMTs engage a wide range of clinical specialities and health-care providers and their leaders should brief providers on the anticipated scope of practice, to ensure their experience and skills closely match the requirements. As clinical standards and practices vary by country, providers should rely on widely accepted international guidelines. Below are some of the most highly regarded reference tools for patient care:

- *Clinical guidelines – Diagnosis and treatment manual*. July, 2020. Médecins Sans Frontières.
- *Essential Drugs*. July, 2020. Médecins Sans Frontières.
- *Management of Limb Injuries – During disasters and conflicts*. December, 2016. International Committee of the Red Cross.
- *Minimum Technical Standards and Recommendations for Rehabilitation*. April, 2016. World Health Organization.

- *Minimum Technical Standards and Recommendations for Reproductive, Maternal, Newborn, and Child Health Care: Emergency Medical Teams.* World Health Organization.

It is each clinician's responsibility to ensure they have sufficient medical indemnity insurance that extends to whichever country they are practicing in. Many organisations carry blanket indemnity insurance for all volunteers, staff and consultants, but the coverage terms should be known prior to deployment.

Clinical operations are a critical aspect of patient care and warrant similar attention and effort. An effective and efficient clinic maximises patient care resources while providing adequate support for both patients and staff. *The Sphere Handbook 2018* is the most referenced guide for humanitarian standards. In the health section of the handbook, standards and indicators for health systems and other essential public health topics are provided for practical field application. Likewise, the water, sanitation and hygiene promotion section provides standards for WASH in disease outbreaks and healthcare settings. This section lists guidelines for clinics including water provision minimums for patients and providers based on procedure, latrine standards, cleaning and handwashing recommendations, and medical waste management. Providers are encouraged to utilise this tool to ensure a safe and healthy clinical environment for patients and staff.

Healthcare in emergency settings

Complex humanitarian emergencies (CHE) refer to a series of chronic and acute disasters and crises that mutually compound the impacts on communities. Commonly, CHEs involve armed conflict, which further exacerbates the difficulty of providing quality healthcare. Despite the challenges, many healthcare providers continue to operate under the auspices of the humanitarian imperative to provide aid. To help inform organizations in such situations, WHO has published a draft of *The Red Book*, ‘a practical guidance document for the principled preparedness, engagement, activation, deployment, coordination, protection, and monitoring of medical teams in armed conflict and complex emergencies.’

Healthcare providers planning to work in conflict areas should take great care to ensure their host organisation (e.g. local NGO or hospital) has adequate infrastructure. Safety and security plans should be well socialised and complemented with quality training opportunities. Hostile environment awareness trainings (HEAT), for example, is designed to teach basic and advanced techniques to mitigate the risks of operating in conflict areas.

Data management and reporting

Clinical settings produce large amounts of data that must be managed carefully to ensure quality healthcare and

uninterrupted operations. Accountability to patients, health authorities, donors and the host organisation depend on quality data collection and management.

Patient data must be collected and managed in a manner that ensures patients' dignity and privacy through physical and electronic security mechanisms. The *Handbook on data protection in humanitarian action*, published by ICRC, details many best practices for humanitarian data management.

Reporting on patient data to health authorities is a common minimum standard in emergency settings, but attention must be paid to maintain protection and rights for each patient. Best practices dictate anonymising data before sharing with third parties.

Disaggregating data by sex, age, race, socioeconomic status and other demographics provides critical analysis of certain population subsets and should be standard practice whenever developing reports. The UN document *Standards for Data Disaggregation* details disaggregated datapoints for analysis.

Patient consent for both treatment and data collection is considered mandatory (acknowledging proper guidance for informed consent in the event of an emergency, unaccompanied minor, etc.). Where consent forms are not in native languages or illiteracy rates are high, trained interpreters can play a critical role in obtaining consent.

The *Minimum Data Set for Reporting by Emergency Medical Teams*, developed by WHO, standardises the datapoints collected during patient care. Now widely adopted by medical teams and health authorities, this tool has simplified the task of compiling and analysing health data between unaffiliated medical teams. All health professionals should default to patient data templates provided by health authorities, but in the event that no templates are provided, medical teams should develop tools based on the *Minimum Data Set*.

In addition to patient care forms, health professionals must provide patients with a copy of their own records at the point of care. Not only does this maximise accountability, it also allows patients to seek high-quality continuing care or a second opinion by providing documentation for future clinicians, especially in situations where emergency healthcare providers are only practicing temporarily.

Providers must be aware of any limitations to access to treatment in the patients' communities; for example, prohibitive pricing, travel distances and quality issues are common in emergency settings. Pharmaceutical and other treatments should be provided in the clinical setting with appropriate continuity when possible. Patients should not be permitted to leave without proper education on treatment protocol. Clinicians should use low-literacy treatment documentation and translators as needed to ensure compliance.

Similarly, referrals require documentation for the patient and receiving clinicians. Referring clinicians must take

efforts to ensure reasonable healthcare access if referring patients. This may involve engaging with transportation services, negotiating with referral centres and encouraging follow-up by the patient if referral care is unavailable. Coordinating with health authorities provides additional support for referral services.

Monitoring and evaluation

Health professionals must establish a monitoring and evaluation (M&E) framework prior to commencing operations. Patient care standards are monitored by experienced clinicians to ensure compliance and quality. Analysis of patient data when adequately disaggregated can determine any issues of access based on demographics.

Patient experience surveys can be conducted in the clinical settings to reveal clinical and non-clinical opportunities to improve operations. As with patient data management, all monitoring and evaluation data must be secured in an appropriate manner and disaggregated to ensure feedback from vulnerable or minority demographics is monitored for protection issues.

Infection prevention and control

By Sara Tomczyk

Appropriate and timely infection prevention and control (IPC) measures are critical during health emergencies, to prevent and control the transmission of infectious disease between healthcare workers, patients and their visitors.

IPC principles

As a key part of the strategy to prevent health threats and strengthen health service resilience, WHO published the *Guidelines on Core Components of Infection Prevention and Control Programmes at the National and Acute Health Care Facility Level* in 2016, followed by the minimum standards for these core components, *Minimum Requirements for infection prevention and control (IPC) programmes*, in 2019.

These guidance documents provide a framework for evidence-based recommendations that should be in place to promote good IPC practice. Core components are outlined below.

- Establish IPC programmes at the facility and national level, with dedicated, trained teams and clearly defined objectives, functions and activities.
- Develop IPC guidelines based on evidence.

- Implement IPC education and training, utilising participatory team- and task-based strategies including bedside and simulation training.
- Establish HAI surveillance to guide IPC interventions and detect outbreaks, with timely feedback of results to stakeholders.
- Implement multimodal strategies to improve IPC practice. Three or more elements should be implemented in an integrated way to improve an outcome or change behaviour.
- Establish monitoring/audit and timely feedback of healthcare practices according to IPC standards. Hand hygiene is a key performance indicator.
- Use workload, staffing and bed occupancy standards according to facility capacity and patient workload.
- Develop the built environment, materials and equipment so that patient care activities are undertaken in a clean and/or hygienic environment. This should include all elements for water, sanitation and hygiene (WASH) infrastructure and services, such as those needed to adequately perform appropriate hand hygiene at the point of care.

IPC Strategies

The WHO IPC core components should act as the basis for good IPC practice and sustained health emergency response. To determine the first steps concerning IPC during a health emergency, healthcare workers should first start with a rapid risk assessment. The immediate IPC measures needed will depend on the type of health emergency, the affected population, the specific setting and the present response capacities. A rapid risk assessment can identify the most important needs and allow workers to readjust strategies and plans accordingly. Various tools have been published by WHO and the European Centre for Disease Prevention and Control to offer objective health emergency and IPC programme indicators that should be measured.

In addition, international standard IPC guidance specific to the identified health emergency should be reviewed. For example, WHO has published IPC guidance for the *Severe Acute Respiratory Syndrome coronavirus 2 (SARS-CoV-2, the strain of coronavirus that causes COVID-19) and Ebola virus epidemics*. The results of the assessments should be shared with the relevant stakeholders, used to determine priority actions and followed by regular audit and feedback for continuous improvement. Ideally, the IPC team should be responsible for conducting the IPC assessment, liaising with the appropriate stakeholders and deciding on further action.

Priority IPC measures and strategies are organised into two tiers: standard precautions and transmission-based precautions.

Standard precautions

Standard precautions make up the basic level of infection control that should be used for the care of all patients at healthcare facilities. Hand hygiene is a crucial component of standard precautions. This should be done by hand rubbing with an alcohol-based preparation or hand washing with soap and clean running water when hands are soiled. Evidence from N. Luangsanatip and others has shown that hand hygiene compliance can be effectively increased using the WHO '5 Moments' approach and a multimodal strategy.

The use of personal protective equipment (PPE) should be guided by a routine assessment of the risk of exposure to body substances or contaminated surfaces and appropriate donning and doffing procedures should be carefully followed. Gloves should be used when touching blood and body fluids. An apron or gown should be used if soiling is likely. Eye protection or a face shield should be worn during procedures where splashes or aerosols are likely.

Other important components include careful handling for prevention of needle stick injuries, respiratory hygiene and cough etiquette, appropriate handling of linens, waste disposal, adequate procedures for routine cleaning and disinfection of the environment, and equipment decontami-

nation. Waste should be safely segregated in well-marked adequate containers and managed by designated personnel with appropriate PPE. Cleaning and disinfection procedures should be consistently and correctly carried out, especially for high-touch surfaces. The process of decontamination is a complex and specialised subject that should be regulated. The Spaulding classification of medical devices and equipment can help to assess the degree of risk of infection and the corresponding method of decontamination, as detailed in N. Damani's 2019 publication, *Manual of Infection Prevention and Control*.

Transmission-based precautions

In addition to standard precautions, further transmission-based precautions should be applied depending on the mode(s) of transmission of the micro-organism involved in the health emergency, as detailed in the US Centers for Disease Control and Prevention *Guideline for Isolation Precautions*. The three principal routes of transmission are outlined below.

- **Contact transmission** includes direct physical contact with the patient (e.g. during a medical examination, bathing, dressing change or management of invasive devices) or indirect contact through contaminated items or the environment.
- **Droplet transmission** generally occurs when large-sized respiratory droplets (>5-10 μm) carrying infectious pathogens come into contact with the mucous

membranes of a person's mouth, eyes and nose (e.g. during coughing, sneezing, talking or medical procedures).

- **Airborne transmission** generally occurs when small-sized particles (<5 μm) remain suspended in the environment for a longer time or are carried over a long distance and then inhaled. In particular, some aerosol-generating procedures have been shown to be associated with increased risk of transmission.

When patients arrive at a healthcare facility, they should be immediately screened using standard case definitions, questionnaires and well-equipped stations, segregated and isolated according to the necessary IPC precautions, using a triage system. Single-room isolation should be used for patients with contact, droplet and airborne transmission precautions. Standard cohorting strategies can be considered when sufficient single-isolation rooms are not available. Likewise, the use of PPE should also be guided by the identified risks for transmission. Laboratory specimens should be collected and handled according to laboratory biosafety guidance specific to the identified health emergency.

A multifaceted IPC approach is particularly important in a health emergency setting. IPC measures should be implemented along with administrative, engineering and environmental controls (i.e. a hierarchy of controls). Administrative controls are policies at the organisational level that ensure sustainable infrastructure, access to supplies, train-

ing of staff and adherence to IPC policies and procedures. Environmental and engineering controls should ensure standards for ventilation, adapted structural design, spatial separation and environmental cleaning.

Conclusion

In a health emergency, preliminary IPC measures based on the mode of transmission should be introduced as soon as possible and ideally lead by the IPC team. The effectiveness of the control measures should be routinely monitored and these data should be used to adapt measures as needed.

Laboratory facilities and diagnostics

By Sabrina Weiß

Basic medical laboratories can be found in (almost) all parts of the world. They are frequently connected to hospitals and carry out clinical diagnostic services. Their regular functions include determining blood parameters and performing tests for non-communicable diseases. Often, they perform microbiological diagnostics such as bacteriology cultures and antibiotic sensitivity testing onsite. In malarial regions, even small health centres are commonly equipped to do malaria testing and some have automated systems to perform molecular diagnostics of common endemic diseases

(e.g. HIV, tuberculosis). Rarely, particularly in low- and middle-income countries (LMICs), hospital laboratories are equipped to perform extensive molecular diagnostics of viral diseases, especially when it comes to rare or non-endemic diseases. Molecular testing capabilities are expensive in terms of both trained personnel and equipment; hence they are often provided by private laboratories or, especially in LMICs, reference laboratories.

Reference laboratories (RL) are commonly established at central or regional levels. They are usually focused on one specific pathogen or group of pathogens and have particularly high qualifications in their respective fields. Their main mandate is to develop and validate diagnostic tests, confirm ambiguous results from other diagnostic laboratories, and maintain specialised capacities, including the typing of pathogen species, which is especially important during outbreaks. They will often maintain a collection of reference strains of 'their' pathogens. Where appropriate, RLs organise proficiency tests for other diagnostic laboratories to monitor qualitative standards. Aside from these diagnostic tasks, RLs coordinate and collaborate with other diagnostic institutions, provide scientific and technical assistance, advise physicians and public health services, and ensure dissemination of relevant information to authorities.

To ensure continuous safety during diagnostic procedures, appropriate biosafety and biosecurity levels need to be maintained in all laboratories working with pathogenic agents. In the laboratory context, biosecurity refers to institutional

and personal security measures designed to prevent the loss, theft, misuse, diversion or intentional release of pathogens and toxins, whereas biosafety is the term used to describe the containment principles, technologies and practices that are implemented to prevent unintentional exposure to pathogens and toxins, or their accidental release. In other words, biosafety is designed to protect people from bad pathogens, while biosecurity protects pathogens from bad people.

There are four biosafety levels (BSL-1 to BSL-4), ranked from lowest to highest risk, into which micro-organisms are allocated depending on, among other criteria, their properties such as pathogenicity and transmissibility, but also on whether or not a pathogen is endemic in a given region. Non-targeted molecular diagnostics commonly require laboratories at BSL-2 level, while targeted diagnostics (e.g. propagation and characterisation of isolates) of highly pathogenic micro-organisms require laboratories with BSL-3 or -4 standards. Pathogens that fall into the highest category (BSL-4) are exclusively viruses, most of which cause acute severe disease in humans (or animals) and for which no vaccination or specific treatment is available (e.g. Ebola virus).

Specialised molecular diagnostic laboratories of various biosafety levels play a pivotal role in the emergency response to infectious disease outbreaks. In acute outbreak situations in low resource settings, local diagnostic capacities can be overwhelmed by the burden of diagnostic requests.

For rapid support in these situations mobile diagnostic laboratories (e.g. EMLab) have been developed. The defining principle of a mobile laboratory is that all necessary equipment is packed in boxes, using a modular system that can be transported by most available means (including airplanes) and set up even in remote parts of the world within a few days. They are commonly requested to support specific molecular testing of various pathogens as they allow for safe processing of even highly pathogenic samples. A special glove box serves as a high-level containment unit that allows for safe handling and inactivation of infectious material. Following inactivation, samples can be further processed for diagnosis using standard laboratory settings.



*Glove box with technical control unit (left) and blower unit (right side).
Photo: S. Weiß*

Maximum containment laboratories

By Andreas Kurth

The maximum containment laboratory – biosafety level 4 (BSL-4) – provides top-level security and allows scientists to handle pathogens of the highest risk group 4, such as Ebola, Lassa, Nipah and Crimean-Congo haemorrhagic fever. A BSL-4 laboratory enables the safe handling, research and diagnosis of life-threatening pathogens without endangering the population and laboratory personnel.

There are two different designs of BSL-4 laboratories: cabinet and suit laboratories. In the first system, the cabinet provides the primary containment (also used for outbreak laboratories in emergency situations); the second system is the worldwide standard for a permanent maximum containment laboratory.

The BSL-4 suit laboratory is an independent, airtight unit with its own air, power and water supply that is specially secured against technical faults by incorporating redundant technical systems. Multi-level safety systems prevent pathogens from escaping into the environment. Negative air pressure is maintained in the laboratory, for example, so that if a leak were to occur, the air would be unable to escape. The air flowing in and out of the high-security laboratory is filtered through a multi-level system (HEPA filter) to ensure that it is pure, and all waste products and wastewater are inactivated completely. A double-door, pass-through autoclave

is available for the heat-decontamination of any laboratory waste. All effluents from the decontamination shower and laboratory wastewater will be (mostly) heat-decontaminated before final discharge. These safety measures have proven to be effective in comparable maximum containment laboratories over decades.



Photo: RKI

Only highly qualified, carefully selected staff are allowed access to the laboratory. Scientists enter and leave the laboratory through a series of airlock security doors. In the BSL-4 laboratory itself, they work in full-body protective suits with their own air supply. On leaving the laboratory, the suits are disinfected in a special decontamination shower.

Because of the great complexity of the engineering, design and construction of BSL-4 facilities and of the work in BSL-4 laboratories, a detailed work manual has been developed and tested in regular training exercises. In addition, an emergency programme has been devised, requiring active cooperation with national and local health authorities. Other emergency services (e.g. fire, police and designated receiving hospitals) should also be involved.

Mobile laboratories

By Jan Baumann

Mobile laboratories are dedicated to strengthening national healthcare systems by providing medical diagnostics in regions with a low density of healthcare facilities or to rapidly scale up diagnostic test capacities in emergency situations. The mobile laboratory can be integrated into public health mobile laboratories, providing routine screening and support to the population (e.g. for HIV and TB), and as rapid response mobile laboratories (RRMLs).

RRMLs were designed to provide immediate diagnostic support in various humanitarian and natural crises such as earthquakes, endemics and pandemics, but also support local health infrastructure during mass gatherings and public events, such as the football World Cup.

To address this wide range of scenarios, each with its own requirements in terms of equipment, procedures and

skills, several institutions came together to define the different types of RRMLs. In 2019, the WHO regional office for Europe in collaboration with Germany's Robert Koch Institute and the Russian Federal Service for Surveillance on Consumer Rights Protection and Human Wellbeing (Rospotrebnadzor), developed a classification system for RRMLs in order to capture and express individual laboratory capabilities and capacities.

The resulting WHO guidance on RRMLs divided them into five types, ranging from very light (Type 1) to multiple heavy units (Type 5) (Figure 3.5). Type 1 RRMLs ('lab in a backpack') and Type 2 RRMLs ('box-based lab') contain limited equipment and consumables for a narrow range of diagnostic procedures. This low overall diagnostic capacity is outweighed by high mobility and the possibility of rapid deployment within 48 hours worldwide. These units are ideal for responding to immediate emergency situations by rapidly scaling up local test capacities or covering the diagnostic needs of populations in remote areas. Higher-level RRMLs (Type 4 and 5) are designed as 'truck-based' facilities or multi-truck units. These heavy, fully-equipped units are able to cover nearly all the diagnostic procedures that stationary diagnostic laboratories can, with a similar diagnostic throughput. Because of their overall scale and capacity, these units require substantial financial commitment for establishment and maintenance, and therefore mainly belong to government organisations, especially in countries where public health systems have to cover

vast areas, such as Canada and Russia. Type 1 and Type 2 RRMLs have been developed in several countries worldwide (e.g. Germany, UK, Belgium, South Africa) primarily by public health or research institutions and, in some cases, supported by national military services.

Even though most RRMLs were initially developed to respond to infectious disease outbreaks, they can be deployed in response to other emergencies, such as natural disasters and mass gatherings, as well as being used for capacity building (e.g. training of national laboratory experts). Each situation will require different diagnostic approaches, ranging from acute PCR diagnostic and serology or blood chemistry to full scale blood culture, so different diagnostic procedures have been organised as diagnostic modules. Each module contains the devices, consumables and knowledge needed for each procedure and this approach allows different, modifiable RRML set-ups, guaranteeing a flexible and targeted emergency response.

The first internationally recognised operation of RRMLs in the field was their massive use during the Ebola virus outbreak in West Africa 2014-16, where over 15 RRML units provided diagnostic support to Sierra Leone, Guinea and Liberia. Afterwards RRMLs were used to provide targeted assistance to national public health structures during localised emergency events, for example in the Democratic Republic of Congo for subsequent Ebola virus response, or in Madagascar to fight plague. Outside of acute emergency scenarios, RRMLs are frequently used for capacity building,

mainly in African countries seeking to improve or expand national diagnostic capacities.

During deployment in emergency response, RRMLs rely on interoperability with other rapid response capacities (e.g. Emergency Medical Teams, EMTs) and local healthcare structures. To facilitate maximum coordination, RRMLs are normally deployed via supranational organisations, such as the WHO Global Outbreak Alert and Response Network (GOARN) and the European Civil Protection Mechanism.

Figure 3.5: Classification of rapid response mobile laboratories (RRMLs).

Source: Adapted with permission by working group RKI/WHO on standardisation of mobile laboratories

¹ **Quality Management System**

² **Laboratory Information Management System**

³ **High Risk of Aerosol Formation**

Mobile Laboratories



Type I

Type II

Type III

Type IV

Type V

Layer 1

QMS¹ and LIMS²

Common requirements & features – consistent across all types of RRML

Layer 2

Throughput



Increase in capability

Biosafety & Biosecurity

	Type I	Type II	Type III	Type IV	Type V
Sample Inactivation	+	+	+	+	+
HRAF ³ -procedures	-	+	+	+	+
Pathogen Cultivation	-	-	-	+	+
WHO Risk Group 1	+	+	+	+	+
WHO Risk Group 2	+	+	+	+	+
WHO Risk Group 3	+	+	+	+	+
WHO Risk Group 4	-	+	+	+	+

Layer 3

Modules

1 basic

2 basic

3 basic

3 basic
+ 1 adv.4 basic
+ 2 adv.

or

Triage module C and RN

1 basic
+ 3 adv.

Logistics

	Type I	Type II	Type III	Type IV	Type V
Commercial, public transport	+	+	-	-	-
Special transport, self-relocation, local	-	-	+	+	+
Self-sufficiency	○	○	○	◐	◑
Average length of deployment	None	None	None	Partially	Fully

Medical logistics

By Liam Callaghan

Supply chain management

All supply chains involve several processes to be completed in order to ensure the right item gets to the right place at the right time. A humanitarian supply chain may have additional challenges including types of funding and support, limitations in transport options, damaged infrastructure and unknown project requirements. Medical items and pharmaceutical stock require enhanced regulations and a tighter control of processes to ensure the quality of product is maintained from manufacture through to treating the patient. Unlike non-medical supplies, pharmaceuticals have increased regulations to ensure good distribution practice (GDP), good manufacturing practice (GMP) and good storage practice (GSP) are maintained.

This section outlines the medical supply chain requirements necessary to support an international health emergency programme and the processes that need to be implemented to ensure quality is maintained throughout. Four factors are essential for effective medical supply chains:

- ensure appropriately qualified personnel, trained in GDP, are consulted from the planning phase onwards;

- ensure all staff involved in the medical supply chain, both office- and field-based, are educated in how to ensure quality is maintained;
- develop quality management systems (QMS) to cover all procedures involved in the procurement, transport and storage of medical items;
- put in place robust quality assurance procedures to record all movement of stock, test for quality throughout and identify any lapses in GDP.

Production and procurement

Good manufacturing practice (GMP) describes the minimum standards that pharmaceutical manufacturers must adhere to during production processes. GMP covers all aspects of pharmaceutical production, from sourcing of raw materials through to delivery of final product to distributor or customer. This ensures that pharmaceutical goods are of consistent high quality, appropriate for their intended use and meet the requirements of the marketing authorisation (MA) or product specification.

All manufacturing processes should be clearly described, with quality testing completed throughout the production chain to ensure all medicines achieve the minimum required standards. All products should contain the specified quantity of active ingredient, be free from contamination and be identified by correct, specific labels. Records of all

products should be maintained and capable of identifying batches in the event of a product recall.

Medical logistics start with identifying which medical supplies are essential for the response, calculating the quantity required and determining the timescale for delivery. Procurement should be made through validated, licensed suppliers with the required procedures in place to ensure manufacturers work to the standards required. Only in exceptional circumstances should medicines be procured from outside well-established suppliers. It is a pharmacist's responsibility to ensure medicines procured from an unknown manufacturer or supplier have equivalent standards of quality (identity, efficacy, safety) to those manufactured to ISO and GMP standards. This may require a suitably trained pharmacist to visit local manufacturers to validate their processes by ensuring the correct quality management system is in place and that all procedures are being monitored and recorded.

Transport

Good distribution practice (GDP) is an essential part of supply chain quality assurance, to ensure pharmaceutical products are appropriately stored, transported and handled as required by the MA or product specification. GDP is required to maintain products in a stable and safe environment to prevent damage to the product, which could result in large financial loss, disruption to supply chains

and ultimately lead to patient injury. A lapse in GDP can cause degradation of the product or a violation in security can lead to falsified medicines entering the supply chain.

A pharmaceutical transport provider must maintain GDP throughout, ensuring all products are stored as per manufacturer's directions, irrespective of the vehicle used. All staff involved in the packaging, transport and receipt of pharmaceutical products should be trained to identify the best practice standards for:

- vehicle suitability
- security
- safety (dangerous goods)
- temperature sensitivity and cold chain monitoring
- documentation required for travel, export and import
- import and export requirements
- handling.

The packaging and mode of transport must protect the cargo against breakage, adulteration and theft, while also maintaining cold-chain and ambient-temperature storage conditions within the required limits. All staff involved in the handling of medicines must be familiar with procedures for packaging of specialist cold-chain inserts, configuration of insulated boxes, assembly of external packaging and the necessary documentation required for import and export of pharmaceuticals.

All transport routes should be risk assessed before travel, with procedures put in place to mitigate any medium-risk activities and a plan to avoid high-risk situations. The transport provider should be able to demonstrate that the medicines have not been exposed to adverse conditions that may affect their quality. A standard vehicle check should be carried out before any cargo is loaded to ensure there are no maintenance, security or hygiene issues identified. Pharmaceutical products should be transported in a different vehicle from other cargo, or adequately separated if there are no other options. The cargo should be packaged to deter unauthorised interference, with adequate measures in place to monitor tampering in transit.

Extreme temperatures can affect both ambient and cold-chain items. Measures should be put in place to monitor the temperature of products throughout and to action any temperature deviation on receipt. Temperature data-loggers should be used to continuously monitor the conditions of the cargo during transport, with all equipment calibrated and maintained to the manufacturer's recommendations. If a temperature deviation does occur, the affected products should be quarantined and the manufacturer contacted to advise on the most appropriate action.

The pharmaceutical regulatory requirements for different countries vary throughout the world. Most countries have strict import and export regulations for pharmaceutical products, especially controlled narcotic and psychotropic drugs or hazardous material. Government departments,

such as the ministry of health or the national drug regulatory authority, ensure the quality, safety and efficacy of all medicines in circulation in their country. They dictate types of medical items allowed, restricted or banned items for import, packaging requirements, labelling requirements, restrictions on import quantities, and documentation required.

National customs agencies will have specific procedures and documentation to be completed before medicines can be sanctioned for import. Logisticians should make arrangements for the import and customs clearance of all pharmaceutical products, especially cold-chain items, before any shipments arrive, to ensure GDP is maintained.

Import licences are completed for each shipment and usually contain specific information including:

- licence number,
- date of issue,
- expiration date,
- name and address of importer and exporter,
- details of items: international non-propriety name, strength, dosage form,
- quantity of shipment,
- name and signature of issuing authority.

As well as import and export licences, additional documentation may be required, including:

- waybill or packing list;
- bill of lading;
- insurance certificates;
- certificate of analysis (issued by the manufacturer, providing quality assurance evidence);
- certificate of origin (details and evidence of the country of manufacture);
- release certificate (details of product batch quality assurance);
- dangerous goods declaration.

Imports of controlled narcotic and psychotropic drugs are usually more regulated, requiring additional documentation and time to process. This may include the:

- import licence obtained from the importing country, listing the internationally controlled drugs or substances;
- export licence from the exporting country, showing the authorisation for the drugs to leave their jurisdiction;
- controlled drug register tracking the movements of the products in transit.

Warehousing and inventory

All premises used for the storage of medical items or pharmaceutical products must be of a standard in line with the manufacturer's requirements, while also maintaining a secure and clean environment. All storage facilities should undergo a GDP inspection by a suitably qualified person to review the security, structural integrity, cleanliness, temperature regulation and control, humidity, controlled drugs storage areas, pest control and warehouse health and safety of the premises.

A warehouse quality management system (QMS) should be implemented to outline the appropriate standard operating procedures required to run and maintain records of all GDP activity carried out in the warehouse. Procedures outlining the receipt, storage, picking, packaging and dispatch of items must be developed to accurately describe the workflow from reception to dispatch.

Good storage practices should be implemented to ensure products are stored off the ground, in a temperature-regulated environment, with adequate spacing to maintain airflow and an appropriate stock management system in place (First Expired First Out). It is important to plan an adequate storage area for all stock items, additional space for replenishment stock and also an isolated quarantine area.

For more information on the disposal of pharmaceutical waste, see the box in the section on medical waste below.

Medical waste

By Sabine Gies

Risks posed by medical waste

Almost all healthcare activities result in the generation of some sort of waste. Most of it (75% to 90%) is similar to domestic waste and referred to as non-hazardous or general healthcare waste. The rest is regarded as hazardous and may pose a variety of environmental and health risks to the individual and the community, including:

- immediate risk of infection through contact with pathogens (e.g. sputum of patients with tuberculosis, faeces of patients with cholera or typhoid fever);
- risk of injury (e.g. cutting with scalpels, blades, broken glass, slides, pipettes);
- risk of injury and infection (e.g. HIV-, HBV-infection through needle stick);
- immediate or long-term toxic reactions after contact with chemicals (e.g. skin reactions after exposure to disinfectants, fixing and developing solutions);
- direct pollution of soil and ground-water by chemicals;
- long-term toxicity to humans and wildlife of persistent organic pollutants (e.g. dioxins and furans in ashes after burning of medical waste).

The immediate risks are infection and injury; long-term risks are toxicity and environmental pollution. An overall effort should be made to generate no or less waste and particularly to minimise the amount of hazardous waste.

Treatment and disposal options

Medical waste must be decontaminated prior to disposal in order to destroy pathogens. This should be done in a way that minimises the risk of the waste becoming an environmental hazard. Management of healthcare waste is regulated by national legal frameworks in accordance with international agreements (e.g. Stockholm and Basel Conventions).

Some of the major UN and humanitarian organisations have defined medical waste management requirements and issued technical guidelines, including the International Committee of the Red Cross (ICRC), Médecins Sans Frontières (MSF), the SPHERE Association, the UN Environment Programme and the World Health Organization (see Credits & References for more details).

Numerous treatment options exist, depending on available infrastructure and resources, and with variable impacts on the environment. Preferred options are technologies in line with international conventions, such as low-heat and chemical-based processes or incineration with flue gas treatment. Where these are not available, temporary solutions

include automated pressure pulsing gravity autoclaving, and single or dual chamber incineration without flue gas treatment. Treatment and final disposal can be either on site or at a remote location. The last resort – still widely used in low-resource settings – is open burning.

How to organise the waste management process

The waste flow is often described as a circle from generation to disposal. The facility management is responsible for the safe handling of waste, conformity with regulations, provision of the necessary equipment and covering of running costs. In practice, persons handling medical waste belong to two groups:

- those generating waste (doctors, nurses, midwives, lab technicians, pharmacists);
- those collecting, transporting, storing and treating waste (cleaners, porters, auxiliary staff, burner or incinerator operators).

The main point of contact between both groups is in the segregation of waste, which is key to all other logistical steps. To organise the waste management process in your location, it is essential to understand where and how hazardous and non-hazardous waste will be treated and disposed of. However limited the available disposal options are, you can still try to make it safer for the people and the environ-

ment. Keep it as simple and as practical as possible for the people involved.

Segregation

Most healthcare activities generate three waste categories that must be segregated into different containers, called the '3-bin standard system' (see Figure 3.6). Additional containers may be required for special waste (e.g. chemical, pharmaceutical, cytotoxic or radioactive waste) that may need specific precautions. For example, in isolation centres where patients with highly infective pathogens (e.g. Ebola) are treated, all waste generated is considered infectious and should be decontaminated and disposed of on site.

Collection, transport & storage

The persons handling waste are often the least qualified of the team, so instructions must be clear and easily understandable. Some items may have considerable value on the local market, so be aware of conflicting interests (e.g. use of empty saline containers as a combustible cooking fuel). Non-hazardous and hazardous waste should not be handled at the same time, otherwise all waste has to be considered hazardous. Staff should wear adequate protective equipment – at least a gown, heavy duty gloves, closed shoes, face mask, eye protection – and use a trolley or wheelbarrow for transport. Equipment used for collection and transport has to be cleaned after use and people handling waste need adequate facilities for washing their hands and clothes.

Segregating medical waste

1 General (non-hazardous)

Combustible:

Packaging and paper; empty saline bottles; non-bloody intravenous tubing and bags; diapers; uncontaminated hats, gowns, gloves, masks, shoe covers*

Non-combustible:

metal, glass containers, cans, food scraps, flowers, yard and plant waste

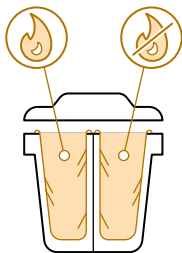

Solid container, lined with plastic bag; separate containers for combustible and non-combustible waste.

2 Infectious and Pathological

Contaminated dressings, bandages, gauze, cotton, gloves, masks, gowns, tubes; containers contaminated with blood or body fluids; blood and body fluids; tissues, organs, foetuses, body parts; microbiological cultures*



Leak-proof strong plastic bag in a pedal-bin.

3 Sharps

Hypodermic needles, intravenous set needles, surgical needles, scalpels, blades, broken ampoules and vials, Petri dishes, slides and cover slips, broken pipettes, lancets*

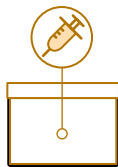

Puncture-proof container, prefabricated or self-made from plastic bottle, canister or cardboard box.

4 Special waste

Broken thermometer or blood pressure gauges; split or expired drugs; spent disinfectants; xylene, fixatives, formalin, toluene, silver, methanol, fixing and developing solutions; chemotherapeutic waste; batteries*

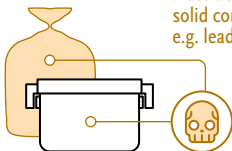

Plastic bag or solid container, e.g. lead box.

*Sub-categories, like pharmaceutical waste, require separate solid containers.

Separate storage areas are required for hazardous and general waste; they must be secured, protected and not accessible to children or stray animals.

Treatment

Incineration is commonly used in low-resource settings, as it is low-cost and easy to install. At high temperatures (> 800°C) it effectively decontaminates infectious waste, including sharps, and substantially reduces waste volume. Use combustible non-hazardous waste for pre-heating and prior to extinguishing the fire. Residual ashes are toxic and must be disposed safely in a nearby ash pit. Be aware that in many places, ashes are used as fertiliser and brought to the fields. This must be prevented.

Items that should never be burned or incinerated include:

- pressurised gas containers
- sealed ampoules or containers
- batteries, broken thermometers
- halogenated material (e.g. PVC plastics)
- chemical waste.

Disposal

Ashes and other hazardous residue can be disposed of in a lined pit at sufficient distance from the water table to avoid contamination of soil and water. Where culturally acceptable, placentas should be collected in a placenta pit. In some places, placentas and body parts are buried by the family – they should be handed over in securely tied, strong plastic bags.

Figure 3.6 The 3-bin standard system for segregating medical waste

Pharmaceutical waste

By Liam Callaghan

Pharmaceutical waste is a category 4 type of special waste. It must be disposed of in a safe and responsible manner to minimise risk to public health and the environment, in line with local and international law (e.g. the Basel Convention). Systems such as suitable sorting of waste, correct filling of specific bins and using the appropriate personal protective equipment will lower the health risk to staff working within a medical facility. The design and implementation of an appropriately engineered waste disposal system is key in protecting staff, patients, populations and the environment from non-disposal, or incorrect disposal, of pharmaceutical and hazardous material.

This disposal process will depend on the technical expertise and equipment available. Clear and appropriate standard operating procedures must be in place to ensure the safe and secure disposal of waste and should cover sorting, handling, transport, storage and treatment.

The theft of any medical items can lead to counterfeit medicines trading or other illegal activities. Controlled drugs should be denatured and witnessed before being processed for disposal. All packaging should also be disposed of in a responsible manner to avoid the potential for counterfeit products to re-enter the supply chain.

Pharmaceutical waste management should be carried out in accordance with the best available techniques and best environmental practices available. The type of disposal method used will depend on quantities, cost, local and international policies.

Pharmaceutical waste should be destroyed in line with local municipal pharmaceutical waste disposal services, if available and appropriate. Ideally, pharmaceutical waste should be disposed of by high temperature incineration (> 1200°C). However if such facilities are unavailable, alternative methods can be used as follows:

- **encapsulation:** immobilising pharmaceuticals in a solid block mixed with cement/lime, within a plastic or steel drum, before being placed in a landfill;
- **inertisation:** procedure to remove pharmaceuticals from their packaging and grind into a paste with water, before being encapsulated;
- **landfill:** placing waste, after treatment, into an engineered and sanitary disposal site to prevent leakage of material into water courses.

A record should be kept of all waste to ensure that all items in the supply can be accounted for. A specific record for the disposal of controlled drugs should be maintained, documenting who is completing the destruction and an authorised witness. This ensures accountability is maintained throughout the supply chain, which can prevent and detect missing stock and theft.

Nutrition in humanitarian response

By Raof Al Waziza

The risks of insufficient dietary intake and malnutrition are prevalent among displaced people, driven by shortages of food and clean water, as well as lack of access to healthcare services, once they are forced to flee their homes. Under-five (U5) children as well as pregnant and lactating women (PLW) are affected the most. Therefore, it is crucial to integrate nutrition with other health services, according to the mandate of the organisation you are working with.

Identifying the host country's integrated food security phase classification (IPC) helps in determining the severity and context of malnutrition in the country and its protocol for approaching it. If you do not have access to data, one of the first measures you can perform to assess the nutritional status of displaced people is to conduct a nutrition survey or a screening process for all U5 children and PLW. Those identified as suffering from malnutrition should be treated on the basis of the country's community-based management of acute malnutrition (CMAM) guideline. Anthropometric measures using mid-upper arm circumference (MUAC) and weight-for-height Z-score are significant tools for the identification of cases of malnutrition.

Depending on the severity of malnutrition, children from 6-59 months could be categorised into either severe acute malnutrition (SAM) or moderate acute malnutrition

(MAM). Treatment is achieved through providing those malnourished U5 children with ready-to-use therapeutic food (RUTF), routine medicines and treatment of medical complications. Referral to inpatient therapeutic feeding centres (TFC) is needed for SAM cases with complications.

Pregnant and lactating women are an important group to be considered, to help break the cycle of malnutrition. If any such women are found to be malnourished, through a routine MUAC measurement, they should be provided with wheat soya blend (WSB) every month. Moreover, it is essential to provide regular sessions for PLW on infant and young child feeding to educate women on proper breast-feeding and complementary feeding.

Chronic malnutrition can develop among displaced people who have spent a long time in camps, where access to diverse food supplies is scarce. To mitigate this, two approaches can be considered based on the country's own protocols. First, raise awareness of the importance of the first 1,000 days, between conception and the child's second birthday. Ensuring diverse and sufficient food intake for both pregnant women and their infants is essential to avoid stunting and permanent lower intellectual skills. Second, consider supplementing U5 children as well as PLW who are not malnourished with micronutrients powder (children under the age of six months and pregnant women in the first trimester should be excluded). Addressing these two points can diminish the impact of chronic malnutrition and reduce stunting in the medium to the long term.

Personal protective equipment (PPE)

By Mario-Alexander Lehmann

Professionals responding to health emergencies at home or internationally are likely to be confronted by different types and classes of PPE. But what does the term PPE really mean? It should only refer to equipment certified to a relevant standard, for example ISO, European Norm (EN) or NIOSH / ANSI standards.

In the European Union, PPE is defined as equipment designed and manufactured to be worn or held by a person for protection against one or more risks to that person's health or safety. The intended use by the PPE manufacturer is therefore the protection of a person. This means other products that have not been designed for personal protection are not PPE, including face coverings and surgical masks. This differentiation is important because for PPE intended to be used against risks that may cause very serious consequences, such as death or irreversible damage to health (category III), the EU mandates that the manufacturer must not only test the product against the required standard (to attain a CE-certification) but also implement an audited quality management system to guarantee the quality of all such products and a defined level of protection.

In health emergencies, the following types of PPE are likely to be used:

- protective eyewear
- respiratory protection
- protective clothing
- protective gloves.

Protective eyewear

Protective eyewear is generally divided into three types: safety spectacles, goggles and face shields.

Safety spectacles

Safety spectacles have been designed mainly to protect the eyes from mechanical risks (e.g. flying particles, pieces of broken glass) or irradiation (e.g. laser beams). Protection against liquid splashes is very limited, as spectacles are mostly not tight-fitting to the face.

Goggles

Goggles offer a higher level of impact protection than spectacles. They are generally more tight-fitting and more mechanically robust. To increase comfort and reduce fogging they can be ventilated (or not) as follows:

- directly ventilated (direct openings in the mask frame),
- indirectly ventilated (covered openings in the mask frame),

- non-ventilated (no openings in the mask frame).

Directly ventilated goggles only offer a limited level of protection against liquid splashes whereas indirect and non-ventilated products are more suitable for this purpose. For fine aerosols and liquid splashes, non-ventilated goggles offer the highest level of protection.

For the correct function of goggles it is essential that they fit tight to the face. There should be no gaps between the face and the goggle. It is important to choose a model that fits the individual physiognomy of the wearer's face.

Fogging is a major issue for professionals using protective eyewear. Some products have an anti-fog treatment or coating – this is essential for non-ventilated goggles.

Face shields

As the name indicates, the intended use of face shields is to protect the face against mechanical risks and direct splashes. They are usually not tight-fitting to the face. Protection against bio-aerosols is very limited, so they should be regarded as additional PPE to be combined with other PPE, for example a filtering facepiece respirator (FFP-mask) or goggles.

Respiratory protection

Respirators can be subdivided into two main functional parts, the facepiece / headtop and changeable filter(s). There are two different types, tight-fitting and loose-fitting. For some types of respirator, the facepiece and filter are one unit (e.g. a filtering facepiece respirator).

Tight-fitting respirators create a negative pressure inside the mask when inhaling. A good seal between mask and face is essential to avoid contaminants leaking into the mask. It is imperative that no facial hair or jewellery/piercings interfere with the seal. Before first use, the fit and the seal to the face should be assessed individually for each respirator by conducting a 'fit-test' to an accepted international standard. Fit-testing is the responsibility of the employer and in some countries, including the UK, USA and Italy, it is mandatory. In addition, the user should read the donning procedure in the user instructions carefully before fitting the respirator, to avoid the risk of leakages and serious health consequences. The user should perform a fit-test every time the tight-fitting respirator is donned.

Loose-fitting facepieces do not rely on a perfect seal to the face to provide respiratory protection and there will be some gaps between the face / neck of the user and the face seal. To provide protection, loose-fitting facepieces require a supply of clean, breathable air into the facepiece that is greater than that needed for breathing. The excess air leads to a continuous airflow from the inside to the outside, stopping

contaminants from entering. The clean air supply can be provided by a powered air purifying respirator (PAPR) or a supply of breathable compressed air.

Different classes of respirator provide different levels of protection to the user. Full face masks and PAPRs generally offer a higher level of respiratory protection than particulate filtering facepiece respirators and half masks. Filters are divided in two main groups, particulate filters and gas & vapour (G&V) filters. Particulate filters are categorised into different classes depending on the filter efficiency and particulate penetration (see Figure 3.7). G&V filters use activated carbons to offer protection against gaseous contaminants, but do not protect against particles. G&V filters can be combined with a particulate filter to offer mutual protection.

Filter Efficiency	Low	Medium	High
European Community	P1 / FFP1	P2 / FFP2	P3 / FFP3
USA	-	N95	N99/N100
China	KN90	KN95	KN100

Figure 3.7 Filter efficiency of respirators

Standard surgical masks are often mistakenly regarded as PPE, but they are not certified to any PPE standard and offer no defined level of respiratory protection. Studies have shown that their filter efficiency is mostly far below the minimum requirements for particulate respirators. Nor do they provide a good seal between mask and face, so they should not be used for protection against biological aerosols. They are designed to reduce the amount of exhaled aerosols or droplets to the environment and may provide a barrier to small droplets and fluid splashes. There are masks available which are certified as both respirator (PPE) and surgical mask (medical device).

Protective clothing and gloves

Coveralls are available as CE category 1 or CE category 3. Category 1 coveralls, also referred to as CE-simple, are only designed for non-hazardous substances to avoid soiling the wearer's clothes. Category 3 coveralls are designed to

CE categories for protective clothing

CE-Category 3



Protection Type with Symbol



Gas Tight



Non-Gas-Tight



Liquid Tight



Spray Tight

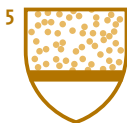

Particle Protection



Limited Splash

CE-Category 1

CE-simple

protect the wearer against harmful substances. They are subcategorised into six levels of protection (see Figure 3.8). Protective clothing that is tested for use against biological hazards is marked with a 'B' (e.g. type 4-B).

Medical gloves for single use are designed to different accepted quality levels (AQL), indicating how many damaged gloves are acceptable per batch. For medical gloves, an AQL of 1.5 is the minimum requirement (no more than 1.5% of gloves will have pinhole defects), while higher quality gloves have an AQL of 0.65. Medical gloves are not designed to be in contact with chemicals and may be damaged by such contact. If gloves are required to provide resistance against chemicals, they should be certified as protective gloves against dangerous chemicals and micro-organisms (EN ISO 374).

For double gloving, the use of different colours for the inner and outer glove should be considered to simplify the detection of holes in the outer glove.

Selection of PPE

‘Personal’ is the most relevant word in personal protective equipment, so it must be checked as adequate and suitable for the individual using it. There is no PPE that suits everyone. PPE only protects if it fits the wearer, is properly selected and is correctly worn. When multiple types of PPE are worn, it is important to ensure their compatibility. For example, unsuitable goggles can affect the face seal of a particulate respirator. Equally, the potential negative effects of taping separate PPE items together should be considered very carefully – for particulate respirators, this is not recommended. If a tight connection between PPE items is needed, it is best to select a single piece of PPE that provides this, for example a full-face mask instead of goggles and a particulate respirator, or a coverall with attached socks/boots instead of a coverall with separate taped over-boots.

Social distancing and border controls

By Christian Enemark

When a contagious and deadly disease is spreading (or threatening to spread) quickly through a human population, responses (treatment and prevention) generally fall into two categories: pharmaceutical and non-pharmaceutical.

Pharmaceutical responses include the use of antibiotics or antiviral drugs to treat infection, and the use of vaccines to prevent infection. In some circumstances, however, drugs and vaccines are non-existent, unaffordable or otherwise unavailable, so only non-pharmaceutical responses can be implemented.

Non-pharmaceutical treatment involves the medical management of disease symptoms, and non-pharmaceutical prevention involves reducing the opportunities for disease transmission by limiting human interactions. At the individual level, non-pharmaceutical prevention measures include the use of personal protective equipment (masks, goggles, gowns and gloves). At the social level, non-pharmaceutical prevention measures are implemented in two contexts of human interaction: domestic (social distancing measures) and international (border control measures).

Social distancing

Social distancing is a non-pharmaceutical approach to preventing disease transmission by limiting social interactions that ordinarily centre on family, friends and work. In the context of a disease outbreak, this necessarily involves people adhering (on a voluntary or non-voluntary basis) to limits on their movements and associations. The intended protective effect of these limits is generally directed towards three categories of people within a population: people known to be infected (confirmed cases); people who are probably infected (suspected cases); and people who might become infected through contact with an infected person (potential cases).

Broadly speaking, **isolation** involves physically separating people with confirmed cases from other (healthy) people, while **quarantine** involves restricting the movements of apparently healthy people who might have been recently exposed to the disease.

Examples of social distancing measures include:

- confinement in the home, or a healthcare setting, of all confirmed or suspected cases;
- voluntary home quarantine of all members of a household with a confirmed or suspected case;
- dismissal of children from school and the closure of childcare programmes;

- requiring adults to work from home (if possible) rather than in their usual workplace;
- cancellation of large public gatherings (for example, sporting events and religious ceremonies);
- placement of barriers and ground markings to support the maintenance of physical separation between individuals in public (on footpaths, in queues and in shops).

Border controls

Border controls take social distancing to an international level. Non-pharmaceutical responses implemented at international borders aim to prevent, delay or inhibit the cross-border spread of a disease outbreak. Border-based measures typically involve monitoring, restricting or prohibiting the entry into a country of people from outside it who are confirmed, suspected or potential victims of the disease.

Examples of border control measures include:

- requiring travellers to complete a written health declaration;
- screening travellers for relevant disease symptoms (for example, using thermal screening devices at ports and airports to detect travellers with a fever);
- requiring intending travellers to undergo clinical testing for infection;

- requiring travellers coming from all or some other countries to self-quarantine at home or in other accommodation for a set period;
- prohibiting outward and inward travel to and from countries experiencing high rates of disease transmission, illness and death.

Social distancing and border controls have the potential to help a government protect the population against a deadly disease outbreak through its public health and healthcare systems. The danger in a severe outbreak is that those systems could be rapidly overwhelmed, as many people over a large area become ill and require urgent medical care. In such circumstances, there is a public health benefit to be gained from promoting social distancing and enforcing travel restrictions. However, non-pharmaceutical approaches to disease control can sometimes be disruptive, unpopular and damaging. This is because societies function and flourish largely because people have regular contact with and depend upon each other.

Some social distancing and border control measures carry risks for a society in terms of individual human rights and collective economic prosperity. The closure of schools, for example, might slow the community-wide spread of a deadly and contagious disease, but it might also make unavailable any healthcare or other essential workers who must then care for their own school-age children. In the longer term, where home-schooling options are unavailable

or inadequate, those children's education and life prospects are undermined.

Requiring workers to stay at home for the duration of a severe disease outbreak can likewise reduce the risk of infection, but in many places and professions it is often difficult or impossible to implement remote-working arrangements. Thus, those workers' economic productivity vanishes and the viability of their continued employment is jeopardised.

Restricting or prohibiting cross-border travel can slow the transnational progress of an outbreak, but it can also inhibit the global sharing of much-needed medical expertise and supplies with disease-affected countries. Worse still, a government's conspicuous emphasis on international border controls might risk externalising the disease outbreak, leading to national selfishness, xenophobia and the scapegoating of foreigners. A government therefore needs to be careful in balancing the benefits and risks of non-pharmaceutical responses when deciding how best to respond.

Vaccination preparedness

By Leesa Lin and Heidi Larson

Vaccination has greatly reduced the burden of infectious diseases, contributing to the large reduction in preventable deaths in the past century and the increase in world life expectancy, driving population dividends across the world.

When facing an acute infectious disease outbreak (e.g. SARS, Ebola or COVID-19) before a vaccine or effective treatment becomes available, health authorities are forced to adopt restrictive measures to slow the spread, such as social distancing, lockdowns, school and business closures, and travel restrictions. However, as countries race to produce vaccines, history has shown that achieving herd immunity through vaccination faces obstacles on operational, legal, and socio-cultural fronts.

First, to eliminate a disease, countries will have to vaccinate an unprecedentedly high percentage of their populations in order to achieve vaccine-level herd immunity. For example, it is estimated that to eradicate COVID-19, the proportions of the population that must have protective immunity from COVID-19 are 65-70% for the US and the UK. Access, delivery and affordability at the population level are practical challenges that need to be addressed.

Second, issues such as a sense of personal freedom and self-determination, religious or other beliefs prohibiting vaccination, and mistrust in authorities frequently hamper the public acceptance of mandatory prophylactic vaccinations. Legal and ethics frameworks, as well as buy-in from the medical profession, must be in place before vaccines can be introduced to the general population. During an active epidemic, deciding who will receive immunisation first is an important and sensitive issue. Authorities need to ensure that the public understand the criteria for prioritisation, well before vaccines become available.

Third, anxieties and concerns around vaccine safety tend to get more public attention than vaccination importance and effectiveness. This gives rise to rumours, misconceptions and space for anti-vaccination messaging. For example, before the measles vaccine became available in 1963, nearly 50,000 Americans were hospitalised and 500 would die of measles every year. Despite the safe and effective use of the measles vaccine for nearly six decades, vaccination rates in the US have declined in recent years as a consequence of false beliefs, with near-record measles outbreaks in the US, Europe and globally during 2018, according to WHO.

In the context of unfamiliar diseases such as COVID-19, there is a broader environment of uncertainty. For population groups that are traditionally marginalised due to ethnic, religious or socio-economic reasons, distrust of authority and fear around top-down disease-control measures may become even more acute. Previous experiences with vaccination and other health interventions will weigh into people's decisions about whether to follow government guidance. If the previous experience was negative, it may undermine public compliance; but positive experiences will be an asset to trust in times of pandemic. It is therefore vital to build public trust and respond to public concerns before, during and after the introduction of new vaccines.

Acute public health emergencies can often intensify pre-existing social inequalities and tensions, and amplify public mistrust in healthcare delivery. The COVID-19 pandemic provoked social stigma and discrimination against people

of certain ethnic backgrounds and those who had been in contact with the virus. This discrimination was fuelled by a public fear of the unknown and a tendency to associate that fear with 'others', according to WHO. The risk of such stigma is that affected people may try to hide the illness to avoid discrimination and may fail to seek the healthcare or the immunisation they need. In addition, financial stresses and logistical barriers to access vaccines further contribute to the challenges of achieving the levels of immunisation required to control disease spread.

To untangle the obstacles to introducing population-based vaccination, multi-disciplinary, in-depth investigations of the challenges faced by countries have long been employed. These investigations often use data derived from a mixed-methods approach including not only medical records and routine surveillance data, but also surveys, focus groups and interviews with multiple segments of the population exploring their concerns and hopes around vaccine uptake. In recent years, scientists have utilised social media surveillance, modelling, mHealth and big data to produce real-time data on public sentiment and behaviours in association with vaccine confidence/hesitancy. There is an urgent need for such community-listening measures, alongside assessing necessary logistical and access concerns, in vaccine preparedness measures.

Zoonotic infections

By Fabian Leendertz

Many human pathogens find their origins in animals. A zoonosis is defined by the World Health Organization as ‘any disease or infection that is naturally transmissible from vertebrate animals to humans.’ Zoonoses may be bacterial, viral or parasitic, or may involve unconventional agents.

Some zoonoses emerged a long time ago (e.g. measles virus, HIV, tuberculosis etc.) but the process is ongoing and zoonotic emergence still represents a serious threat to global public health, as the COVID-19 pandemic demonstrated.

Sources for zoonotic infections

There are many different types of zoonoses and different ways you can get infected with a pathogen originating in animals. Some of the more common sources of exposure for people in health emergencies or those travelling on mission are outlined below.

Food related

Transmission in a kitchen setting includes risks from consuming raw or undercooked meat, or contact with contaminated food items, plates or cutlery. For example, avoid cutting raw chicken on the same board as food you consume uncooked. Eating wildlife meat is a higher risk than eating domestic animal meat, since we don't know

which pathogens are circulating in the wild. In many low-income countries, there may be little or no food control, so the risk is always higher. The long-standing rule ‘Cook it, Peel it or Leave it’ remains a sound guideline when travelling.

Direct exposure to animals

Stay away from all kinds of animals, especially when they approach you. Never feed any animal, or you will attract them. In many settings there will be dogs, cats or other domestic animals but also wildlife – captive or otherwise – which has become habituated to humans. It may be tempting to touch or pet them, but remember that entails a high risk for you. There are many incidences where people have been scratched or bitten by various animals, including monkeys. You should only approach animals if you work with them (e.g. on zoonotic infections). In this case, consider the appropriate protective equipment and methods for safe data and sample collection.

Vector borne zoonoses

Vectors are another key source for zoonoses, for example mosquitos, tsetse flies or ticks. Reduce the risk of being bitten by these arthropods by wearing proper clothing. Ensure you are fully clothed as soon as the sun goes down, use insect repellent during daytime and at night, and always sleep under a mosquito net.

What factors are increasing zoonosis emergence?

COVID19

Diseases transmitted from animals to humans

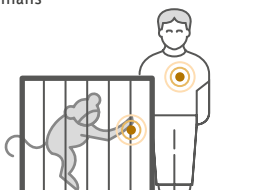

Antimicrobial
resistance



Illegal and poorly
regulated wildlife trade

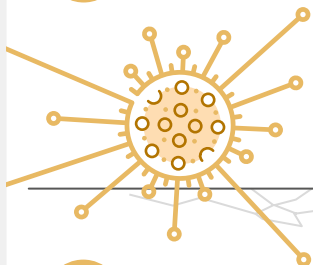

Climate
change



Intensified agriculture
and livestock production



Deforestation and other
land use changes

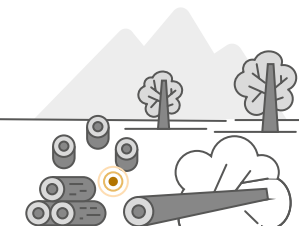

Exposure to aerosols

It may seem like a good idea to clean out your room if it is very dusty or dirty. However various viruses, including those spread by rodents or other small mammals, can be transmitted through aerosols (fine solid particles or liquid droplets suspended in the air). The most prominent examples are the Lassa virus and Hantaviruses. If you are in a high-risk area, make sure you wear a FFP3 mask and avoid creating aerosols.

General recommendations

For each of these risks it is important to gather as much information as possible before travelling. Make sure you receive the relevant vaccines and think about counter-measures. Remember, there are also the unknown pathogens, so make sure you respect baseline rules even if a risk is not known.





Chapter 4

Preparing for deployment*

Before deploying, make sure you are well equipped with the knowledge and tools needed to tackle upcoming challenges. You will also need to leave time to have a health check-up, get vaccinated against the relevant diseases and ensure your domestic arrangements are in order. You are the one responsible for preparing yourself both professionally and personally.

Everything outlined below is subject to rules and regulations that have been set by receiving organisations with respect to policies and concepts guiding missions and operations in the field. Consequently, this chapter can only serve as a general overview of issues to be taken into account.

* For full credits, references and further reading on the subjects covered in this Chapter, please refer to Credits & References Chapter 4 on p. 570

Understanding the situation

The challenges you might face while on mission range from dealing with unknown cultures and local legislations, eating unusual food or living in difficult conditions to performing first aid on an injured colleague or negotiating your way out of an ambush. Personal preparation prior to a mission will boost your capabilities to perform professionally and to deal with the challenges you will encounter.

The basic questions you need to ask yourself before deployment are: where are you going and why?

Where are you going?

As a crisis manager, you have probably been told to 'expect the unexpected'. You might also have been told to be flexible and open enough to face all kinds of surprises. However, the fact that you are bound to encounter unexpected challenges along the way does not mean you should refrain from reading about the country and region of deployment and preparing yourself as well as you can. Understanding the mission background and familiarising yourself with the country of your future (temporary) home is indispensable.

Therefore, before you leave, try to get a comprehensive understanding of the environment, history, culture and living conditions of the location to which you are being

deployed. Make sure you conduct the necessary research on the region and find out more about the following:

- **Culture and history** – food, people, living conditions, languages, religions, cultural traditions & faux pas, history;
- **Economy** – national & regional economies, inflation rates, currency, exchange rates;
- **Geography** – climate, terrain, natural hazards, means of transport, telephone codes;
- **Politics and security** – political landscape, upcoming events (e.g. elections), security infrastructure, security incident history, militias, revolutionary movements, external/geopolitical influences, conflicts/disputes;
- **Public health** – public health system (quality and accessibility), closest hospitals & primary healthcare facilities, occurrence of infectious diseases (epidemic & endemic) and non-infectious diseases, risk of accidents, risk of encountering dangerous or venomous animals; other potential health concerns.

The following is a sample list of possible sources you can draw on for general as well as insider information on the country of deployment:

- contacts you may already have in the country of deployment;
- your employer's induction pack (if available);

- travel advice from your country of origin's foreign ministry;
- websites of think tanks, United Nations' country offices, commercial assistance providers, risk consultancies, etc.;
- news organisations – local and international (e.g. Reuters, BBC, Deutsche Welle);
- situation reports, conflict analysis and briefing papers;
- university publications;
- weather forecasts;
- WHO websites on vaccinations and potential diseases;
- mapping services (have an updated map at hand upon arrival, if available).

Why are you going there?

Take time to become familiar with your employer's or partner institute's mandate, purpose and background. It is your responsibility to understand your mission duties and tasks before deployment. Study the employment contract and ToR for your position. If anything is unclear, ask the entity that is hiring you for clarification. Look into the available documents that form the basis of the mission or project to which you will be deployed. You should receive these documents during your induction.

What should you do before departure?

Once you have fuelled yourself with essential knowledge about the country and region of deployment as well as your mission's purpose and mandate, it is time to take care of the final domestic, medical and professional arrangements before packing and leaving. This section will guide you through the most important steps.

Domestic arrangements

Preparing the family

It can be daunting for family members to learn of your upcoming departure. Even though they might not have to face the same challenges that you will be tackling while on mission, your family will nonetheless have to cope with various emotional – and sometimes material – hardships while you are away. For instance, spouses often undergo the frustration of being physically separated from their partners, worrying about them constantly, while struggling to manage household responsibilities single-handedly.

Communication can be a crucial factor when preparing your loved ones for the news of your departure. Take the time needed to explain clearly where you are going and why it is important for you to go there. For example, it

could be a good opportunity to engage with them while researching and reading about the history and culture of the country of deployment as well as your mission mandate and, if feasible, the security management system of your employer or host organisation. Familiarity with core security procedures and contingency plans may help your family to feel more confident.

Although 24-hour news reports can keep your loved ones up-to-date, consider how such rolling news might be perceived by family members. Make sure they remain aware of the risks and drawbacks that accompany around-the-clock media coverage. In order to avoid misunderstandings and misplaced concerns, you should try to maintain regular contact with family members through available means of communication.

Household chores

During deployment, especially when it lasts for extended periods, your family members and partner will most likely create new routines to manage household chores and responsibilities. Make necessary domestic arrangements before you leave.

These measures can range from paying bills in advance for rent or utilities to finding someone to water plants or look after pets. If deployment is for a long period of time,

you might need to arrange mail to be redelivered or for someone to pick it up.

Your will and other legal documents

Before deployment, you might want to prepare a power of attorney document, a living will and also a last will and testament. Writing a will might feel strange, but crisis management brings its own set of risks, so it is sensible to plan for every scenario, including the worst case.

Power of attorney: This is a written document that allows you to give a person of your choice the authority and right to act on your behalf if any legal or economic issues arise while you are on mission. Power of attorney (POA) can be general, limited or enduring. A general POA allows the designated person to act on your behalf in almost all legal acts. If you only wish to have them represent you on certain issues, then you can resort to a limited POA contract whereby you specify the powers to be adopted and the issues to be addressed by the chosen person. Finally, an enduring POA becomes valid if you lose your ability to handle your own affairs (e.g. if you are injured or incapacitated). As long as you are mentally competent, and if any problems arise, you have the right to consult an attorney and revoke that power from the person you entrusted it to.

Living will: A living will is a written document in which you describe the medical treatment you do or do not wish to

receive in case you are seriously injured or terminally ill; it also designates a person to act and make medical decisions on your behalf. This becomes valid and takes effect only if you are not able to express your wish in any other way.

Last will and testament: This written declaration states how you wish your property to be handled after you die. Without one, the fate of your possessions, savings and custody of children could lie in the hands of the courts.

In any case, check the national legal requirements for any of these documents in your respective country of residence.

Medical arrangements

Immunisation and vaccination

You may have to work in areas where poor public health conditions prevail. Therefore, you should get all the vaccinations required for diseases prevalent in your area of deployment. Ensure your vaccinations are up-to-date and registered in an international certificate of vaccination or prophylaxis (WHO standard recommended). Take time to arrange for vaccinations before departure and bear in mind that some may require a few weeks before they become effective.

You may not always have time to get immunised once the phone rings telling you to be at destination X within 48

hours. If you are on an emergency roster or there is a good chance you will be deployed, make sure you are up-to-date before that phone call. **You must always be covered for diphtheria, hepatitis A and B, MMR (measles, mumps and rubella), poliomyelitis and tetanus.** Depending on your area of deployment, you should also be covered for meningitis (ACWY), rabies and typhoid fever.

Yellow fever is now known to be prevented throughout life by a single yellow fever vaccination (standard WHO advice). At the time of writing, some countries still require a certificate showing that you have been vaccinated within the last 10 years. Prior to your departure, check whether the countries you are travelling to require such documentation and make sure that any yellow fever vaccination is recorded with the date and signature in your international certificate of vaccination or prophylaxis. Other vaccines do not normally have to be certified except under special circumstances.

If you are being deployed to or likely to visit an area where malaria is known to occur, you will need specialist advice before going, including taking antimalarial prophylaxis.

Diseases you are well advised to think about ahead of time include:

- malaria;
- meningitis – the ‘meningitis belt’ spans much of Central, East and West Africa, and some other regions;

- yellow fever, present in much of sub-Saharan Africa and Central and South America;
- Japanese encephalitis, a risk in South and Southeast Asia;
- cholera (a good oral cholera vaccine exists and is a wise precaution if deploying to a disaster zone or complex emergency);
- other infectious diseases, such as COVID-19, Zika virus, Ebola virus, etc.

This list is by no means exhaustive. It is advisable to visit a physician experienced in travel medicine as early as possible before deployment, to get expert advice on which diseases may exist in the places where you will be working. You are also recommended to take a first aid course to gain knowledge and confidence in case of emergencies. See Chapter 5 for more information on common illnesses, infectious diseases and how to stay healthy while on deployment.

General checkups

Ensure that you have regular health screenings or checkups to remain in the best of health and to manage any medical problems on time.

Health screenings should include:

- general medical examination, including blood and urine tests (make sure your blood group is documented in a recorded blood test);
- breast examination and PAP (cervical smear) for women;
- dental checkup;
- visual acuity;
- chest X-rays and ECGs: although some agencies require them, they are not generally advised except under severe field conditions or when clinically necessary.

Insurance

Make sure you have an insurance policy that covers everything from minor accidents and illnesses to life-threatening ones, including medical evacuation and repatriations. Such insurance may be included in your work contract. However, make sure you always check the scope, detail and amount cover and ensure that all the items you consider necessary are included in the policy. If not, you might want to take out private insurance in addition to what your employer offers you. Carry the contact details of your insurance company on you at all times.

Professional arrangements

Understanding the job

Before embarking on a deployment or mission, make sure you identify what your key areas of responsibility will be and how you can go about accomplishing your tasks. Handover is an essential step within that process. It can be advisable to get in touch with your predecessor(s), if there were any, as well as independently try to find out information on:

- the basic planning documents of the mission/operation;
- the history of the project and its goals;
- challenges, lessons and good practices specific to your mission;
- the location of resources and support structures;
- key information on personnel, partners and stakeholders;
- current needs, priorities and issues;
- SOPs, manuals, guidelines or other sources dealing with your job.

Make sure you understand and accept your job description, come to terms with your responsibilities and manage your expectations. Due to the complexities of recruitment, you might be given tasks that do not reflect your responsibilities in previous positions. To avoid bad feelings or frustration

that may arise from this, make sure you manage your own expectations before accepting a job offer.

Equipment

Each organisation has its own rules about what equipment you may or may not use during deployment. Depending on the kind of mission you are embarking on and the organisation you will be working for, the equipment that you need to prepare and take with you might differ from what you are used to.

Check equipment regulations before departure and ensure that you procure what you need.

Preparatory training and capacity building

As a professional, you may already have relevant work experience. Still, your upcoming tasks may be different and new to you, depending on the nature and stage of the crisis, country of deployment, organisation and changing external factors.

You may be offered training by your nominating agent or employer – either online or in person. If your receiving organisation offers you a mission-specific pre-deployment training course, it is essential that you attend it.

Most organisations require their mission personnel to have recently attended a first aid course or hold a valid certificate.

Make sure you are still familiar with the content and that any certificate you hold is not more than two years old.

For many missions, personal safety and security training and/or an electronic high-risk environment security training is a precondition for deployment. You should complete compulsory web-based courses before your departure.

International travel register

International travel registers are maintained by many ministries of foreign affairs. Registering your details with your foreign ministry before travelling overseas allows the embassy or high commission in your country of deployment to contact you in case of emergency or other exceptional circumstances.

German citizens working abroad can register electronically on the ELEFAND system. It is essential to register online, even if you have previously been entered in the manually maintained list. You will be asked to confirm and update your contact information at regular intervals. For more information, visit: <https://elefand.diplo.de/>.

What should you pack before departure?

Clothing and equipment requirements for a deployment or mission vary according to the location, climate, culture, season and the state of the local economy. You should expect to be fully independent and self-sufficient throughout the mission with regard to clothing and personal effects. During your periods of leave, you will have to consider restocking on personal items.

The following sections detail some recommended documents, personal items and first aid equipment to pack and take with you.

Documents and related items

international travel ticket

valid passport (check length of validity)

visa

spare passport photos (plenty of them)

work contract & travel authorisation (if needed)

international certificates of vaccinations

international driving licence

insurance information/documentation

contact information for head office, country offices,
main contact person's details in-country, embassy
contact details

small amount of cash in low denominations, in a
locally acceptable currency (e.g. US dollars)

notebook, pens and pencils

deployment handbook

copies of all essential documents

updated map of where you're going

It is advisable to store important information in more than one location – for example, emergency phone numbers should not be saved only on your mobile phone.

Personal items

The following is a checklist of the items that you need to consider packing before going on a deployment or mission. Some of them might be climate-, country- or organisation-specific. It is important to pack essential items in your hand luggage in case your main luggage does not arrive on time. However, be aware of hand-luggage regulations and also keep in mind that in some places the use of a camera can be restricted or forbidden.

Personal items

holdall or rucksack

culturally appropriate clothing, including long-sleeved garments and headscarves if local customs require them (short sleeves and shorts may not be acceptable in some countries)

water-resistant, sturdy walking shoes/boots

sleeping bag with liner

identification kit (i.e. vest and ID)

dry wash in case of water shortages

torch with spare bulb and batteries

sewing kit (not in hand luggage)

plastic bags

universal adapters for electronic equipment

fishing line (multi-purpose, as it is very tough)

mosquito net and mosquito repellent
(for warm climates)

camera/camera phone

personal laptop and storage device for electronic data

clothing appropriate for the location, elevation, time of year and expected duration of the mission

smart clothing for official meetings

rain gear

extra pair of glasses and sunglasses

towel

ear plugs

pocket knife/multi-tool (not in hand luggage)

washing powder

candles

water bottle with purification filter and/or tablets

compass, personal GPS

mobile phone (with a SIM card that will work in your area of deployment) or satellite phone

alarm clock

spare batteries/solar charger (if suitable)

Medical preparations

Medical / first aid kit

Most organisations will ensure that you are equipped with adequate first aid kits. Some organisations advise you to purchase them yourself. If you are not issued with the necessary equipment, you should carry an individual medical kit to care for minor illnesses or injuries. The contents of the medical kit should be clearly marked, including the names of the medications and instructions for their use. Use a sturdy waterproof container to store the medical kit's contents. For some quantities and types of medication, it is useful to carry a written declaration from a doctor that confirms they are required for personal usage. Suggested first aid supplies are listed below.

Standard travel first aid kit

prescription medicine for expected length of stay

painkillers for fever, aches, etc.

anti-histamines for running noses and allergies

antacids and anti-emetics for abdominal upsets

antibiotics (generic)

alcohol wipes

bandages (triangular, elastic)

extended haemorrhage control equipment
(e.g. tactical tourniquet, emergency bandages
– only if trained in their usage)

protective gloves

scissors (not in hand-luggage)

Malaria prevention kit

insecticide-treated mosquito net

DEET-based insect repellent

malaria prevention tablets

a standby treatment kit

Diarrhoea treatment kit

packets of oral rehydration salts

loperamide (Imodium) tablets

ciprofloxacin tablets (250 mg or 500 mg)

water purification tablets

Blood-borne diseases prevention kit

syringes

sterile needles

Skin protection kit

sun block / sun screen / moisturiser

powder (e.g. with anti-fungal medication)

hydrocortisone cream against skin allergies or insect bites

antiseptic cream for cuts and abrasions

Other supplies

epinephrine (adrenalin) self-injection kits x 2
(if you have a history of severe allergies/anaphylaxis)

inhaler sets x 2 (if you suffer from asthma)

if you're on regular medication, take adequate supplies and a list of medicines (with dosages and frequency) signed and stamped by your doctor

antiseptic cream for cuts and abrasions

Extended first aid kits

If you are travelling to an area with **malaria risk**, take a standard travel first aid kit, plus the malaria prevention kit above, including antimalarial medication relevant to your specific travel area.

If you are travelling to a **crisis zone**, an area without organised emergency medical services, or an area where the nearest available health clinic is over 30 minutes away, take a standard travel first aid kit, plus the following:

Crisis zone

1 x tourniquet

1 x emergency bandage with pressure bar

1 x hemostatic wound dressing or tamponade
(e.g. QuikClot)

1 x nasopharyngeal airway

1 x resuscitation cloth or mask

1 x chest-seal

10 x alcohol-based disinfectant wipes

1 x rescue blanket

If you are travelling to an area affected by an **epidemic or pandemic**, take a standard travel first aid kit, plus the following:

Epidemic / pandemic

5 x face masks per day

3 x FFP2 face masks per day

1 x shoe covers (pair) per day

10x disposable gloves (pair) per day

1x protective gown per day

1 x safety goggles

1 x face shield

2 x small bottles of alcohol-based hand disinfectant /sanitiser (one-handed bottle)

symptom tracker/diary

2 x test kits, if available

Combine the above first aid kits as required for the area(s) you are deploying to.

Medical records

You are advised to maintain your own health record showing important health information and keep it with you at all times, in case of accident or illness. Your employer or deploying organisation should also keep a copy in a secure location, to be used as proof of identity and proof of life (e.g. in the event of your being kidnapped).

Your health record should include the following data:

- dates and results of health checkups (including dental and visual);
- medical illnesses and medication being used;
- allergies, particularly to medication/drugs;
- vaccinations;
- personal information, such as blood group;
- health insurance details;
- name and contact details of your usual healthcare provider, e.g. personal doctor or medical specialist.



Chapter 5

Staying healthy and safe in the field*

Staying healthy and safe during deployment is a precondition for being able to help others effectively. Your ability to look after yourself and your level of preparation is not just key for personal safety, team safety and the output of your work, it also affects your credibility and the reputation of your organisation. Taking care of yourself and your colleagues will help ensure that often-scarce resources are not wasted on visiting responders. As a health professional, you should take personal responsibility for learning basic self-care skills to cope successfully with the challenging reality of everyday life in the field.

This chapter will equip you with some fundamental knowledge required for staying healthy and safe in potentially unfamiliar and stressful situations.

* For full credits, references and further reading on the subjects covered in this Chapter, please refer to Credits & References Chapter 5 on p. 570

Staying healthy

By Deike Rosenbusch

This section highlights some simple precautions to minimise the chances of you falling ill. Your personal health is of utmost importance, as you are only able to fulfill your role in an emergency if you are healthy yourself.

General health advice

It is important to keep your personal health in mind before, during and after working in a health emergency.

Organise a health checkup before your departure, especially if you are affected by a chronic condition. You must be able to work in a setting with potentially limited access to adequate healthcare and necessary medication. Take enough medication with you for the duration of your deployment and identify the most reliable health facilities before you arrive.

Learn about the key health risks and prevention methods in your area of deployment. Among other sources, the German Ministry of Foreign Affairs offers travel and safety information for each country. Ensure that your vaccination status is up to date and plan ahead if you need more vaccinations.

Working in an emergency situation may be extremely stressful. Make sure that you feel mentally prepared to enter such

a situation. See the mental health and stress management section of this chapter for more information and advice.

Hygiene

Maintaining good hygiene is one of the most important ways in which you can protect your personal health during your deployment.

Personal hygiene

The standards of personal hygiene that you are used to may not be available in your country of deployment. Establish what type of accommodation and personal hygiene facilities will be provided during your deployment. Be aware that some hygiene products, such as tampons, may not be available in your country of deployment. Make sure you bring enough hygiene products with you.

Food and water safety

Poor food quality and water safety are among the main reasons for falling ill. The following recommendations apply when you prepare food yourself, as well when you eat in a restaurant or buy food from street-vendors.

- Cooked food that has been kept at room temperature or under the sun for several hours constitutes one of the greatest risks of foodborne illness. Make sure your

food has been thoroughly and recently cooked and is still hot when served. Egg yolks should be firm and not runny.

- Avoid any uncooked food, apart from fruit and vegetables that can be peeled or shelled. Avoid fruit with damaged skin. Remember the dictum '**Cook it, Peel it or Leave it.**'
- Certain species of fish and shellfish may contain poisonous biotoxins even if they are well cooked. If you are not sure, avoid them.
- No person who has sores, cuts or broken skin on their hands should handle food.
- When the safety of drinking water is doubtful, filter the water, boil it for a full minute (ideally for three minutes if over 2,000 metres), or use reliable disinfectant tablets or a UV-light water purifier.
- Beverages such as hot tea or coffee, wine, beer, carbonated soft drinks or fruit juices that are either bottled or packaged are usually safe to drink. Check if the lid of the bottle is properly sealed before purchasing.
- Ice cubes and ice cream from unreliable sources are frequently contaminated and may cause illness. Some table sauces in restaurants are diluted with unsafe water. Avoid them.
- Unpasteurised milk should be boiled before consumption.

Prevention against insect bites and stings

Depending on your country of deployment, protection against insect bites and stings plays an important role in protecting yourself from disease. Insects that bite or sting include wasps, hornets, bees, horseflies, ticks, mosquitoes, fleas, bedbugs, spiders and midges. Most insect bites and stings are not serious and will get better quickly. However, mosquitoes in particular can transmit serious illnesses such as malaria, dengue fever and Zika virus. Follow the advice below to avoid insect bites and stings.

- Avoid going outside around sunset and sunrise.
- Keep skin covered as much as possible, from before dusk till dawn. Keep in mind that some mosquitoes also bite during the day.
- Wear long sleeves and trousers. Wear shoes and socks when outdoors and close the gap between shoes and trousers.
- Apply a DEET-based insect repellent to exposed skin (concentration of 50% DEET in high-risk areas).
- Always sleep under a bed net (insecticide-treated, if in high-risk areas).
- Avoid using products with strong perfumes, as those attract insects.
- Be careful around plants, rubbish, compost or stagnant water.

Personal protective equipment

Depending on the disease, personal protective equipment (PPE) in a health setting consists of protective clothing and shoes, masks, gloves and goggles. PPE is crucial in preventing transmission of certain diseases such as Ebola or SARS-CoV-2. It is essential not only in treatment settings, but also during various activities such as cleaning, waste management and safe burials.

Contact your deployment organisation and confirm they have an adequate supply of PPE in your mission country. If needed, bring your own PPE for travelling to and from your country of deployment. Follow the instructions provided and train in how to put on and take off your PPE. WHO provides training sheets and videos on how to put on and remove PPE. For more information on PPE, see Chapter 3.

First aid

Knowing and applying simple first aid principles can save lives, even when you only have basic equipment at your disposal. It is important to realise that first aid is a practical skill – to be effective, it requires regular training. You are strongly advised to attend a professional first aid course and maintain a valid, up-to-date first aid certificate. Always keep a first aid kit with you. See Chapter 4 for a list of suggested medical items to pack before you deploy.

Be aware that the risk of a surgical emergency (e.g. road traffic accident) may be higher in your country of deployment. Take extra care when travelling by road: always wear a seatbelt in a car or a helmet on a motorcycle, even if it is not common practice in your country of deployment.

If you are involved in an emergency involving infectious diseases, keep the following general steps in mind:

- isolate the person that has potentially contracted an infectious disease;
- depending on the disease, start contact tracing and isolate relevant contacts;
- if you are affected yourself, contact your deployment organisation and consider a medical evacuation (MEDEVAC).

Common illnesses

Diarrhoea

Diarrhoea is a common problem while travelling or staying abroad. To avoid getting diarrhoea, ensure good hygiene (especially hand hygiene) as well as water and food safety. Many diarrhoea attacks are caused by viruses, bacteria or unusual food (e.g. camel milk); these are self-limiting and clear up in a few days.

It is important to avoid becoming dehydrated. As soon as diarrhoea sets in, drink more fluids, such as bottled, boiled or treated water or weak tea. Eat slowly and sensibly if you can and avoid dairy products. The body loses water, salts (especially sodium and potassium), water-soluble vitamins and other trace minerals through diarrhoea. In order to replenish some of these losses, it is recommended that you consume at least three litres of fluid within the first three hours and continuously drink fluids thereafter, especially oral rehydration solution (ORS) in the correct dilution. If there is no ORS available you can create your own solution with six level teaspoons of sugar and half a level teaspoon of salt added to one litre of clean water.

Loperamide or antibiotics (e.g. ciprofloxacin, azithromycin) may reduce the frequency and severity of diarrhoea. You should seek medical help if there is any blood in your stools or accompanying fever and vomiting. Diarrhoea that lasts for more than three days requires medical attention. Use

your own toilet in case of diarrhoea or, if this is not possible, clean the toilet and washbasin properly with disinfectant. Always disinfect your hands after each visit to the toilet.

WHO offers more information here:

<https://www.who.int/topics/diarrhoea/en/>

Fever

A high body temperature (i.e. 38.5 °C or more) should always be taken seriously, especially if you are in a malaria-prone area or have come from one in the past. You should see a doctor if a fever persists or is worsening. It helps to be aware of some important causes of fever, outlined below.

- **Meningitis:** severe headache, stiff neck, often a rash that does not fade when you touch it.
- **Acute bilharzia or katayama fever:** often accompanied by wheezing and itching 20 or more days after swimming in an area where bilharzia is common, such as Lake Victoria or Lake Malawi.
- **Urinary tract infection:** aching in the loins, often with nausea, shivering and frequent urination that creates a burning sensation.
- **Typhoid:** progressive fever and feeling increasingly ill – with no response to malaria treatment. It is usually accompanied by diarrhoea, sometimes with coughing and a faint rash.

- **Sepsis or septicaemia:** alternate shivering and sweating, often in the presence of an infected bite or other skin infection like a boil or cellulitis (warm, infected feet or legs); low blood pressure, high heart rate.
- **Heat stroke:** also causes high temperature.

Acute respiratory diseases

Acute respiratory infections of viral and bacterial origin can affect your upper or lower respiratory system. Depending on the location of the infection, your symptoms may vary. Symptoms may be mild (congestion, runny nose, sore throat, fatigue, cough) or more serious (shortness of breath, raised respiratory rate).

Infection is particularly dangerous for older adults and people with immune system disorders. Seek medical attention if you have a fever over 39°C or difficulty breathing. Most causes of an acute respiratory infection are not directly treatable, since they are caused by viruses. Therefore, prevention is the best method to ward off harmful respiratory infections. The following precautions are recommended:

- get vaccinated against MMR (measles, mumps, and rubella) and pertussis – this will substantially lower your risk of getting a respiratory infection;
- you may also benefit from influenza and pneumococcal vaccinations;
- practice good hygiene;

- avoid smoking.

Treating infections, parasites and bites

Infections, parasites and bites can be serious, so proper treatment is important.

Malaria

Falciparum malaria can be life-threatening and it is common in most of the malarial regions in tropical countries. Depending on the recommendations for your country of deployment, the season of your deployment and your length of stay, take malaria prevention tablets with you and take them regularly. A standby treatment kit is only recommended in a few situations. Discuss malaria prevention with a specialist before your departure.

If dengue fever, chikungunya or Zika are likely to be present, also protect yourself from day-biting mosquitoes. The Aedes mosquito causing these three illnesses bites during the day, especially early morning and late afternoon. Refer to the advice above on how to avoid mosquito bites.

Even if you take all these precautions, you may still get malaria. If you develop a fever, sweats and chills, a bad headache or other symptoms that could be attributed to malaria, get tested as soon as possible by a reliable doctor or laboratory. The use of rapid diagnostic tests has greatly

improved the ease and speed of testing for malaria, but a high-quality malaria blood smear is still recommended.

If this is not possible, if you do not trust the result or if the correct treatment is not available, self-treat within 8-12 hours of the time your symptoms first started. In all cases you should put yourself under the care of a trusted doctor or other health worker as soon as possible.

WHO offers more information here:

<https://www.who.int/malaria/en/>

Dengue fever

Dengue fever is a mosquito-borne viral infection that can cause severe illness very rapidly. The *Aedes* mosquito, which spreads this severe flu-like illness, tends to bite during the day. Typical symptoms are high fever, severe headache, muscle and joint pain, and extreme fatigue. If you experience these symptoms, see a doctor and get tested. Complications are rare but there is a haemorrhagic form of dengue and some people develop a more serious infection on subsequent attacks. There is no cure for dengue fever. A vaccination exists but WHO recommends that it is only given to persons with confirmed prior dengue virus infection.

Since the symptoms are congruent with those of malaria, it is wise also to get a malaria test when you go for a dengue test. But be aware: it is possible to have a false negative

on a malaria test if the parasite count in your blood is still low. In case of doubt, get re-tested for malaria the day after. Remember that while dengue fever will subside with rest and time, malaria will not disappear without medication and can get very serious if left untreated.

WHO offers more information here: <https://www.who.int/health-topics/dengue-and-severe-dengue>

Zika virus

The Zika virus is a mosquito-borne illness. Symptoms include fever, erythema (rash or redness of skin), conjunctivitis, headaches and muscle pain. However, symptoms are often mild and many people are infected without realising it. Sexual transmission has been confirmed. The Zika virus can be passed from a pregnant woman to her foetus and infection during pregnancy can cause serious birth defects with lifelong effects on the physical and mental health of the child. Cases of Guillain-Barre syndrome (paralysis of muscles, including life-threatening paralysis of respiratory muscles) can also be caused, but much less frequently. The Zika virus is likely to occur in many countries where *Aedes* mosquitoes are found. Men returning from affected areas should avoid unprotected sex with female partners of child-bearing potential for three months, while women should avoid unprotected sex for two months. Women who are pregnant or who may become pregnant should avoid areas where the infection is occurring. No vaccination or

special treatment is currently available. This means that avoiding mosquitoes is essential.

WHO offers more information here:

<https://www.who.int/emergencies/diseases/zika/en/>

Viral haemorrhagic fevers

Most viral haemorrhagic fevers are spread by close contact with infectious cases, while some are spread by mosquitoes or ticks. Symptoms usually start with fever, headaches, muscle pain and conjunctival suffusion (redness of the eyes). Further information on the specific dangers, causes and best methods of prevention are best checked at the time of any outbreak. Be aware that dead bodies may still contain active viruses. HIV, for example, may survive in a dead human body for as long as a week; Ebola may also still be contagious after the death of the host. If you must touch dead bodies, make sure you wear PPE and disinfect yourself as soon as possible afterwards, including your clothes.

WHO offers more information here: https://www.who.int/topics/haemorrhagic_fever_viral/en/

Pneumonia and respiratory infection

Symptoms include coughing, shortness of breath, fever, pain when breathing deeply and blood sputum in severe cases. If you experience these symptoms, seek medical

advice as soon as possible. Timely treatment with effective antibiotics usually shortens the duration of these illnesses. Remember that pneumonia's symptoms can mimic those of malaria.

If you are deployed to a country where any severe episodes of flu or flu-like illness are known to be occurring in the area or in a worldwide outbreak, follow official guidelines carefully. If you take a shower somewhere hot and the water is stagnant in the pipe, let the water run first and be careful not to ingest it. It could cause life-threatening legionella pneumonia, whose symptoms can include high fever, cough and weakness. Mission members should consult with their doctor on which antibiotics they should take with them to use in emergencies, such as acute respiratory infections.

Skin and wound infections

Skin diseases are mostly related to poor hygiene, infected bites or eczema, or a variety of less common parasitic and other infections. Parasites can cause severe skin infection (e.g. scabies). If there is no adequate medical service available, take a photo, send it to a medical facility or your general practitioner, describe the symptoms and ask for advice.

In hot climates, even small cuts, grazes, bites and other wounds can quickly get infected. Use an antiseptic cream or powder. Cellulitis – hot, red skin spreading outwards

from an infection or upwards from the feet and toes – can develop extremely rapidly. Start a high-dose antibiotic at once, under medical supervision. Do not shower without flip-flops, as warm, damp environments may be breeding grounds for fungi.

Dirty wounds or breaches in the skin provide a potential entry point for tetanus infection, which can result in muscle spasms or seizures – ‘lockjaw’ is a common sign. Make sure you have been immunised against tetanus (a primary course of three injections with a booster every 10 years). If you have not been immunised, get a tetanus shot without delay.

Bites from dogs and venomous animals

Clean any bites scrupulously with soap and water, or better still with disinfectant. Get them looked at by a doctor or other trusted health worker. Bites often become infected and you should start a course of antibiotics even if no infection is obvious. Usually, bites will not be closed surgically because of the risk of infection. You should make regular visits to a medical facility, depending on the depth of the bite, and ensure your tetanus immunisation is up to date.

If you are bitten by a snake, scorpion, spider or other animal, first remove any rings or bracelets from the bitten area as these may cause harm if swelling occurs. Then immobilise the bitten area, but never use a tight arterial tourniquet. You should report the incident immediately to a medical

facility. Take a photo or try to describe the animal, as you may need treatment.

Do not waste time! Rabies is a vaccine-preventable viral disease which occurs in more than 150 countries. Dogs are the source of up to 99% of all rabies transmissions to humans. Infection causes tens of thousands of deaths every year, mostly in Asia and Africa. Cleansing the wound immediately with soap and water can be life-saving.

Unless you are in a region known to be free of rabies, it is essential that you report to a competent health facility at once if you are bitten. Even if you have been fully immunised against rabies prior to deployment, you will still need two further vaccines. If you have not been immunised, you will need five post-exposure vaccines and probably also human rabies immunoglobulin, which can be hard to get hold of, even in developed countries.

Everyone deployed to a country where rabies is endemic should be immunised prior to their mission. However, remember that rabies vaccination only buys you time – you must still get shots after being bitten, and you must get them rapidly. If you know there are rabies-infected animals in your surroundings (symptoms in dogs include disorientation, staggering, seizures, foaming at the mouth), ensure that you know where to get vaccinated for rabies.

Sexually transmitted infections (STIs)

These are very common among mission personnel. The key rules are never to have unprotected sex and to avoid sex when alcohol has significantly blurred your decision-making. Also report any signs such as abnormal discharge, sores or genital warts. If in doubt whether you may have become infected, get checked out at the end of your mission as some STIs may cause no symptoms, but can cause infertility and other problems. Include an HIV test.

Health threats when working in medical facilities (nosocomial infections)

Healthcare workers have a high risk of nosocomial or hospital-acquired infections, as they frequently come into contact with infectious agents through their work. The main routes of infectious disease transmission are:

- contact – e.g. methicillin-resistant staphylococcus aureus (MRSA), vancomycin-resistant enterococcus (VRE);
- droplet – e.g. bordetella pertussis, seasonal flu;
- bloodborne – e.g. HIV, hepatitis B;
- airborne – e.g. tuberculosis, measles.

You are advised to take the following precautions to avoid infection:

- use PPE wherever appropriate;
- follow standard operating procedures whenever coming into direct contact with a patient, including contact with blood – avoid needlestick injuries in particular;
- seek medical assistance when you develop symptoms – remember to mention your stay in your country of deployment if you develop symptoms after your return.

Personal preparedness when working in the laboratory

Working in a laboratory demands additional precautions regarding biological, chemical, physical and other safety hazards. At the beginning of your mission, familiarise yourself with the laboratory you will be working in, as outlined below.

- Note the location of emergency equipment such as spill kits and PPE.
- Identify emergency exits, evacuation routes, meeting and shelter-in-place locations. If they do not exist, develop evacuation and shelter-in-place procedures. If the laboratory covers multiple floors, develop a plan for each location and determine the best way to communicate during an emergency.
- Make yourself familiar with all refrigerators, freezers, incubators and other equipment, noting those with emergency outlets. Ensure critical materials are kept

in freezers and refrigerators with emergency power outlets.

- Move all chemicals to appropriate storage locations. Separate incompatible chemicals. Frequently dispose of chemical wastes and clean out unneeded chemicals. Make sure safety data sheets for laboratory chemicals are available.
- Ensure electrical wires and equipment are in adequate condition and gas cylinders are capped and secured.
- Discuss accidents and near misses to prevent future accidents.

WHO provides videos about a wide array of aspects regarding safety in laboratories: <https://www.who.int/ihr/publications/biosafety-video-series/en/>

Health advice for those responding to emerging and high consequence infectious diseases

By Thomas Kratz

Emerging diseases and high consequence infectious diseases (HCID) are becoming increasingly prominent, so you are likely to find yourself being deployed to a setting where these diseases occur.

According to WHO's 2014 publication *A brief guide to emerging infectious diseases and zoonoses*, 'an emerging disease is one that either has appeared and affected a population for the first time, or has existed previously but is rapidly spreading, either in terms of the number of people getting infected, or to new geographical areas.'

The European Centre for Disease Prevention and Control describes the impact of HCID as follows, in its 2019 publication *Health emergency preparedness for imported cases of high-consequence infectious diseases*: 'Patients with such diseases typically develop severe symptoms and require a high level of care. Moreover, case-fatality rates can be high.' Classification of a disease as emerging or an HCID can differ from one country to another, and not all emerging diseases are HCID or vice versa.

This section focuses on emerging diseases and HCID with person-to-person transmissibility, potential for rapid spread

and the possibility of many fatalities, caused by pathogens from the two highest biosafety levels (BSL):

- BSL-4 pathogens: e.g. Ebola virus disease (EVD), Marburg virus disease (MVD), Lassa fever (LF), Crimean-Congo haemorrhagic fever (CCHF);
- BSL-3 pathogens: e.g. COVID-19, SARS, MERS, pneumonic plague.

Additional characteristics of these emerging or high consequence infectious diseases include:

- lack of suitable or approved vaccine and / or specific treatment;
- potential of anxiety and fear, particularly due to uncertainties (e.g. lack of data on symptom prevalence, ways of transmission) and risk of personal harm (e.g. severe disease outcome, physical and social isolation, death);
- potential of severely damaging health systems as well as increasing fear or mistrust among the population.

Deploying on a mission to tackle emerging or high consequence infectious diseases is a serious undertaking. It will be a complex, challenging and exhausting experience, but it can also be an enriching and instructive one. The advice offered below applies particularly for these settings, and should be understood as complementary to the more general health and security advice presented in this chapter.

Before your deployment

- Get a briefing on the epidemiological and security aspects of the setting you're deploying to.
- Get a briefing on the general health situation and the particular HCID details of your destination.
- Get a briefing on the psychological aspects of your deployment.
- Ensure you have a medical examination.
- Check if your health insurance policy covers medical evacuation (MEDEVAC) related to such infectious diseases and that an emergency assistance service (e.g. SOS International) is in place.
- To facilitate a possible MEDEVAC, you must ensure you are eligible to enter a country with the requisite treatment facilities (e.g. high-level isolation unit). If you have to be evacuated to Europe or the USA, you may need to procure the relevant visa prior to your deployment.

During your deployment

- Take care of your physical well-being. This includes taking all necessary preventative measures, such as malaria prophylaxis. Monitor your body temperature daily. It is important to stay healthy and thereby avoid the occurrence of any symptoms (e.g. fever) that could be interpreted as indicative of contagion.

- If you develop *any* disease symptom, minimise your contact with others and consult a physician immediately. In missions related to emerging diseases / HCID, a physician should be designated for staff well-being.
- Look after your mental health. You and your colleagues are likely to face some difficult times. Listen to each other, be respectful and mindful. Organising social events can be very helpful, but consuming too much alcohol or taking drugs is not.
- Stay calm if you are suspected of or diagnosed with an emergent disease / HCID. Your organisation should do the utmost to assist you. Make sure you self-isolate and comply with the instructions of the treating physician(s).

After your deployment

- Respect the safety or quarantine period, if indicated.
- Ask for a post-mission medical examination.
- Seek a psychological debriefing and, if need be, further psychological support.
- If you develop symptoms within the incubation period: self-isolate and *call* a physician or treatment facility with experience in the diagnosis and treatment of emerging or high consequence infectious diseases.

Dealing with climatic extremes, environmental risks and challenges

As altitude sickness, hypothermia and heat stroke can be dangerous, this section will instruct you on how to cope with extreme climate and altitudes.

Too high

Beware of altitude sickness, which can set in at any height above 2,000 metres and can be fatal. When climbing or travelling to heights above this, try to take a few days to get acclimatised. Ensure you sleep no more than 300 metres higher than the night before. Maintain your fluid levels. If you become short of breath while at rest, develop a persistent cough, experience a pounding headache or feel drowsy, return to a lower altitude as quickly as possible.

Too cold

Hypothermia can quickly set in with any combination of cold weather, high elevation, strong wind and being wet. To prevent this, wear several layers of loose-fitting clothing, with a waterproof outer layer, and cover head, neck and hands. Set up a 'buddy system' so that individuals can look after one another. Signs of hypothermia include feeling intense cold, shivering, drowsiness or confusion. If this happens to you or your companion, warm up without delay by having warm sweet drinks, sharing warmth in a sleeping

bag or having a bath with water up to 40°C. Check for signs of frostbite (an aching or numbness, often in the hands or feet, with the skin feeling rock-hard and looking very pale or purplish). Do not drink alcohol.

Too hot

Working in high temperatures brings with it the risk of heat stroke or sun stroke. This is when your body's cooling mechanism (including your ability to perspire) breaks down. In these situations, your body temperature escalates to 39°C or above, you feel hot and dry, your pulse rate goes up and you may feel sick and confused. Get into a cool place at once, drink cold non-alcoholic beverages if you are able to, get sponged down, fanned or have cold water poured on your body to evaporate the heat. Get medical help, as this can be an emergency.

Hazardous materials

Hazardous compounds can be gases, liquids or solids. They are linked to typical pathways of exposure (e.g. air, bodies of water, soil) and to typical impact types (e.g. human mortality, effects on life support systems including drinking water, fisheries and agriculture). In crisis situations or emergencies, you may be exposed to hazardous materials (hazmat). Trained hazmat experts should handle such situations; however, if you find yourself faced with a potential hazmat incident, take the following actions:

- leave the area immediately;
- do not operate radios, mobile phones or other electronic devices within 500 metres of the hazard;
- notify local emergency officials or community leaders of the situation, so they can cordon off the scene;
- stay away from fumes, smoke and vapour;
- remain upwind, even if there is no smell;
- be aware of changing weather conditions and wind directions – note wind speed, direction, type of precipitation, temperature and cloud cover.

When exposed to hazmat, consider the following, weather-related effects:

- on a warm day, chemical substances will tend to evaporate quicker than in cold temperatures;
- high winds will disperse gases, vapours and powders;
- precipitation may be problematic if a weather-reactive substance is released;
- precipitation may also be a benefit as it can slow down the dispersal of airborne materials and reduce the area of impact.

In any event, inform local and/or international authorities to get access to experts, further information and advice.

Mental health and stress management

By Martine Bourquin

Working in crisis management environments can expose you to stressful situations and conditions. You may realise that a situation your colleague judges to be extremely stressful is one that you can handle easily. It is only natural that different people react differently to stress triggers and that coping strategies vary from one person to another.

Experiencing stress during crisis management can be helpful. It can focus your attention, increase your concentration and mobilise the necessary energy you need to achieve your everyday goals.

However, failure to cope effectively with stress may cause a decrease in productivity, prove detrimental to your functioning and affect the work of your entire team. Early prevention can stop the stress reaction from escalating into a real problem in the future.

This section will focus on three types of stress:

- cumulative stress
- acute stress
- vicarious trauma

It will provide you with tips on how to deal with them and how to take advantage of the resources at hand to speed

up your healing process. For more information on post-deployment stress, see Chapter 8.

Cumulative stress

Cumulative stress is stress that builds up over time and, if not well managed, can gradually lead you to perform less effectively. Some form of stress in missions is inevitable, but failure to address cumulative stress may lead to burnout.

What creates cumulative stress?

Everyone has different reasons for feeling stressed. Some can cope with stress better than others by consciously controlling their state of mind. The following are possible causes of cumulative stress:

- problems with basic needs (e.g. poor housing / food / water, lack of privacy);
- travel delays;
- lack of safety and security;
- health hazards;
- immobility, inactivity, lack of exercise;
- problems at home, missing family and friends;
- witnessing violence or tragedy;
- inability to make a difference, lack of progress, apathy among responders or survivors;
- noisy or chaotic environment;

- malfunctioning equipment;
- no rest or relaxation periods;
- unclear or constantly shifting tasks, unrealistic expectations (imposed by yourself or others);
- media attention and coverage of security incidents close to your location;
- non-recognition of work or hostility towards your efforts;
- pressure to achieve;
- unsupportive or difficult colleagues or superiors;
- anxiety about the mission, your accomplishments, responsibilities or skills;
- lack of resources or limited control of the situation;
- cultural and linguistic differences;
- permanent availability and constant demands from HQ.

How to recognise cumulative stress

It is important to recognise indicators of cumulative stress. It may be helpful for you to share with your colleagues some signs that you are not handling your stress satisfactorily. Indicators of cumulative stress include:

- narrowing of attention, impaired judgment, loss of perspective;
- disorientation, forgetfulness;
- impatience, verbal aggression or being overly critical;

- inappropriate, purposeless or even destructive behaviour;
- anger;
- sleep disorders;
- susceptibility to viruses or psychosomatic complaints;
- hyper-emotions (e.g. grief, elation, wide mood swings);
- physical tension, headaches;
- increased substance abuse;
- eating problems, (e.g. lack of appetite, eating too much);
- lack of energy, interest or enthusiasm;
- withdrawal, depression or loss of sense of humour;
- inability to perform;
- questioning basic beliefs and values, or cynicism.

How to minimise cumulative stress

Experience has shown that pre-deployment training in building up resilience to stress, greater awareness of early-onset indicators and prompt action to establish coping mechanisms all have a positive effect on reducing cumulative stress and avoiding burnout. It is natural to experience cumulative stress during a crisis management operation, but it is a condition that can be identified and managed. Some of the actions below can help you to reduce cumulative stress:

- know your limitations, manage your expectations, accept the situation;
- get sufficient rest, relaxation, sleep and exercise;
- eat regularly, drink enough water;
- change tasks and roles;
- identify and act on the source of stress;
- communicate clearly with colleagues and ask for explanations to avoid misunderstandings;
- take time off regularly;
- create personal space;
- control substance abuse;
- talk, laugh or cry with your colleagues;
- practice prayer, meditation, progressive relaxation;
- pamper yourself – read, sing, dance, write, listen to or play music, work on a hobby, take a sauna, cook a meal;
- participate in non-work related social activities;
- get access to supervision from outside (e.g. through online services).

Acute stress

Acute or traumatic stress is a powerful type of stress brought on by sudden exposure to a traumatic event or a series of such experiences. It is classically described as a set of normal reactions to abnormal events such as:

- witnessing casualties and major destruction;
- serious injury to yourself or injury / death of a relative, colleague or friend;
- events that are life-threatening (e.g. natural disasters, man-made crises);
- events that cause extreme physical or emotional harm.

It is important to remember that strong emotional, physiological, behavioural and psychological reactions occur in the immediate aftermath of a traumatic experience.

How to recognise acute stress

Physical reactions:

- nausea, gastro-intestinal distress;
- trembling, shaking, sweating, shivering;
- general weakness;
- elevated heartbeat, rapid respiration, hyperventilation;
- headache, stomach problems.

Cognitive reactions:

- racing, circular thoughts;
- confusion, dissociation;
- intrusive images;
- negative thoughts;
- loss of perspective, lack of perception.

Spiritual reactions:

- loss of trust;
- questioning the meaning of life;
- loss of purpose and hope;
- changes in beliefs.

Behavioural reactions:

- constantly talking about the event;
- exaggerated, black humour;
- inability to rest or let go;
- sleep and appetite disturbances, substance abuse;
- withdrawal;
- irrational activities.

Emotional reactions:

- rapidly shifting emotions;
- shock or disbelief;
- numbness, anxiety, fear;
- exhilaration;
- helplessness, feeling overwhelmed;
- anger, sadness;
- guilt, shame, hopelessness, grief;
- decreased attention, difficulties in decision-making.

Psychological first aid

Psychological first aid (PFA) should be offered after any traumatic incident. Like medical first aid, PFA provides initial support until further help arrives (if needed). PFA may include:

- ensuring a sense of safety;
- helping people to contact family members;
- providing food, shelter and other practical help;
- offering comfort and reassurance;
- listening;
- providing information.

It aims to reduce the distress initially caused by traumatic events and to promote the short- and long-term adaptive functioning of affected persons.

Steps towards recovery

Going through a potentially traumatic experience can often fundamentally challenge our sense of safety and meaning. We can often feel helpless and out of control. It is important that we take proactive steps to address these sensations as soon as we can, including:

- if possible, try to re-establish a routine;
- when not working, try to distract yourself (e.g. with books, films) – avoid dwelling on the experience;

- try to connect with others and seek support from your family, friends, colleagues or other survivors of the same or similar events;
- participate in memorials and organised events concerning the traumatic event;
- challenge your sense of helplessness by reclaiming some control (e.g. take positive action, help others, seek creative solutions);
- make it a priority to get enough rest and take care of yourself.

Dealing with strong emotions

Allow yourself time and be aware that you may well experience strong emotional reactions. Try some of the following:

- do not rush the healing process;
- try not to be judgmental about the feelings you have;
- connect with people!
- talk to someone you trust or who is trained or experienced in traumatic reactions;
- practice relaxation techniques;
- pamper yourself and try to ensure the essential sleep you need for recovery.

What you can do as a colleague:

- spend time with your traumatised colleague, offer support and listen with understanding and a non-judgmental attitude;

- respect their privacy, but encourage them to get enough exercise, rest and nourishing food;
- help them to resume normal day-to-day life, encourage them to take up hobbies and social activities; be persistent but not pushy!
- If trauma survivors display anger or aggressive behaviour, do not take it personally – these behaviours are linked to acute stress reactions.

When to seek help for acute or traumatic stress

Try to seek support through your own social networks (e.g. friends, family, colleagues) as much as possible during the aftermath of experiencing a traumatic event. If this support is not immediately available or you do not have access to these networks, try to find a specialist. As stated above, extreme emotional reactions to traumatic experiences are perfectly normal.

However, if you find your functioning is profoundly affected, or if your reactions are taking a long time to subside or are worsening, you should seek professional assistance. This especially applies if you display the symptoms listed below, four to six weeks after the incident.

Intrusive symptoms:

- recurrent and intrusive recollections of the event;
- recurrent dreams of the event;
- acting as if the event was recurring;

- intense distress at exposure to cues that symbolise the event;
- physiological reactivity to cues or reminders of the event.

Avoidance and emotional numbing symptoms:

- efforts to avoid thoughts, feelings or conversations about the event;
- avoiding activities, places or people associated with the event;
- inability to recall important details surrounding the event;
- diminished interest in formerly enjoyable and important activities of life;
- a feeling of detachment, estrangement and alienation from other people;
- a restricted range of emotional experiences;
- a sense of a shortened future accompanied by a notable lack of preparation for the future.

Emotional arousal symptoms:

- hypervigilance for danger;
- exaggerated and distressing startle response;
- sleep disturbances;
- difficulty concentrating;
- irritability or angry outbursts.

If these criteria are present and impairing normal functioning, you should contact a professional through your insurance provider or other medical networks. You may be in danger of developing post-traumatic stress disorder (PTSD), a severe and disabling condition that can be alleviated with professional help.

It is possible that your seconding or contracting organisation can provide access to services to support you in dealing with stress or trauma. Be sure to research all available services and how to access them prior to your deployment.

If you feel like you can no longer remain in the mission because of the trauma that you have experienced, do not hesitate to take the necessary steps to end your contract. There is no shame in leaving a stressful and traumatic situation.

Vicarious trauma

Vicarious trauma, also known as secondary trauma, can affect anyone who is exposed on an ongoing basis to the suffering of others. Therefore, anyone who works in crisis environments can be vulnerable.

You are particularly at risk if:

- you care deeply about your work, but tend to set unrealistic expectations;
- you have not processed previous traumatic experiences;

- you lack social support or find it difficult to talk about your feelings.

Common reactions to vicarious trauma

Vicarious trauma is a cumulative process that makes gradual changes over time to a person's emotional, physical and spiritual well-being. Common reactions include:

- loss of a sense of meaning, purpose and hope;
- difficulty maintaining healthy work / life boundaries;
- relationship problems;
- cognitive confusion and disorientation;
- unpredictable emotional shifts.

Coping with vicarious trauma

Because vicarious trauma is such a gradual process, there is no quick fix for recovering from it. However, helpful strategies for dealing with vicarious trauma are noted below.

- Take good care of yourself. Ensure that you are getting adequate sleep, nutrition and moderate physical exercise.
- Take regular breaks. Create space to get away from your job, both physically and mentally (e.g. reading books, engaging in hobbies, spending time with friends, taking short trips).
- Examine your limits. Do you need to make changes to the amount of time you spend in crisis environments

(temporarily or permanently)? Do you need to balance crisis work with other kinds of activity? It can be helpful to talk this over with a friend or counsellor.

- Explore your motives. Think about what inspires you and where you find a sense of higher purpose. Look for ways to connect with yourself more deeply (e.g. meditation, journal writing).

Addiction to trauma

If people have suffered early trauma in their lives or are repeatedly exposed to acute stress in adulthood, it is possible to become addicted to the experience (the term ‘adrenaline junkie’ may be familiar). Otherwise known as ‘repetition compulsion’, it refers to the need to persistently revisit disturbing experiences.

Clinical research suggests that this may represent an attempt to gain mastery over a previous trauma. It is also thought that the excitement of the risk acts as a distraction from feelings of loss and confusion that might otherwise prove overwhelming.

Common symptoms of trauma addiction

If you are in the grip of repetition compulsion, you may:

- feel bored and numbed by ordinary life back home;
- only feel engaged and alive in violent and unpredictable surroundings;

- compulsively watch violent or disturbing films or listen to aggressive music;
- engage in sexual promiscuity or other risky behaviour;
- repetitively become involved in abusive relationships.

Responding to trauma addiction

In many ways, repetition compulsion needs to be treated like any other addiction. That may mean a period of abstinence in order to 'detox'. It can be very helpful to take breaks from adrenaline-fuelled crisis environments to reflect on your experiences and talk through your reactions.

Addiction of any kind is a very isolating experience, which can usually only be fully resolved in relationships with others. If you are aware of difficult or traumatic experiences that you sense you have not come to terms with, it is important that you find someone to discuss this with.

Some people prefer to talk to one other person (e.g. a trusted friend, colleague or counsellor) but others find group support more helpful. However you do it, clinical experience indicates that dealing with past experiences can help people move on in their working lives with a renewed sense of purpose and engagement.

Substance abuse

By Martine Bourquin

The high levels of stress that can form part of the daily work of civilian experts on mission can sometimes become a breeding ground for substance abuse. By substance abuse, we are not only talking about cases of drug overdoses or drunkenness, but rather about a long and complex problem of intoxication and addiction.

While addiction can cause serious health problems, intoxication can pose safety risks as well as low levels of productivity in the workplace and increased absenteeism. While each type of drug affects a person's mind and body in different ways, there are general signs and symptoms to watch out for, detailed below.

CAGE screening tool for alcohol abuse

C 'Cut down' – have you ever felt you should cut down on your drinking?

A 'Annoyed' – have people ever annoyed you by criticising your drinking habits?

G 'Guilty' – have you ever felt bad or guilty about your drinking?

E 'Eye opener' – have you ever had a drink first thing in the morning to steady your nerves?

Physical evidence

- smelling of alcohol
- bleary-eyed
- intoxication (slurred speech, unsteady on feet, confusion)
- injection marks on arms (drugs used intravenously)
- tremor and sweating of hands (alcohol or sedative withdrawal)
- multiple bruises, especially if some are more recent than others
- loss of weight and gaunt appearance
- accidents at work, at home or on the road

Habits and moods

- multiple mood swings within a single day (alternation between drug-induced euphoria and delayed depression)
- increased irritability, nervousness, and argumentativeness
- poor relations with fellow workers and management
- avoidance of supervisor
- tendency to blame others

Absence from work

- frequent absenteeism, especially after the weekend or pay days
- frequent days off sick
- bad timekeeping
- unexplained absences

Work performance

- reduced quality and quantity of work
- increasing number of mistakes and errors of judgment
- loss of interest in work
- failure to meet deadlines

How to deal with substance abuse

If you recognise the aforementioned symptoms in your colleagues, then they could be struggling with alcohol or substance abuse. The best solutions you can offer them (or seek out if you suffer these problems yourself) are guidance, support and treatment.

Talk to staff members about the situation and collectively agree on a realistic plan of action. Include existing professional HR and HQ support and consultation. If you find that the situation has escalated to a more serious level and is starting to affect work performance, discuss it with

a supervisor or contact whoever is in charge of offering confidential counselling.

Make sure that you or the person concerned seeks medical advice and that this issue is dealt with in a confidential manner.

Staying safe

This section gives information and advice on how to protect yourself and how to deal with situations that threaten your safety and security. While some mention is made of security aspects, which focus on deliberate actions by others intending to inflict harm, the main focus in this section is on safety and on how to protect yourself from unsafe situations which might arise for unintentional reasons.

Please remember that these guidelines are merely advisory and do not supersede instructions, standard operating procedures (SOPs) or contingency plans issued by the security office of your particular mission.

The following topics should be covered in greater depth during safety and security training, such as the hostile environment awareness training (HEAT) that you should try to participate in before deployment.

Cybersecurity

By Gregor Schaffrath

In the context of crisis management operations, cybersecurity is a significant priority as sensitive data is constantly being transmitted. If valuable mission data falls into the wrong hands, the consequences can be harmful. Through awareness and responsible use of data the chances of cyberattacks can be minimised. As a mission member, it is important to consider carefully what you are transmitting over public networks, especially if the compromising of that information could affect your own or the mission's safety.

The cyber domain pervades every aspect of modern life. The digital world and 'real life' are now so intertwined that they can no longer be considered separately. This has led to a shift from IT security to cybersecurity. While IT hygiene – such as choosing good passwords, avoiding careless interconnections of devices, or operating devices in safe environments – remains important, it is no longer sufficient.

There is no absolute security against cybercrime. Security is defined in terms of interdependent goals and trade-offs, for example anonymity versus authenticity. All security measures bear costs (e.g. financial, usability) which have impacts on how security should be addressed in practice. Security decisions cannot be taken based on efficacy (does it

work?) alone, but always need to be balanced by considering efficiency (how do benefit and cost compare?).

It is important to note that security (as opposed to safety) is defined by the presence of malicious intent. The presence of an adaptable adversary explains why compliance to a static list of best practices is insufficient to address the threat. Security is, therefore, not a static, generic concept, but tied to a well-defined scenario in terms of motivations (or goals) and capabilities – both on the defending and the attacking side.

Threat analysis

Any cybersecurity measures should, ideally, be the result of a thorough, individual threat analysis. At the very least, you should ask the following questions:

What is the motivation of your adversary?

An attacker seeking to compromise arbitrary victims (e.g. to collect devices for a botnet for subsequent use) will attack in an undirected fashion. Whether or not an attacker invests effort into an exploit for a specific vulnerability is likely to be an economic decision. Moving out of mainstream configurations and taking basic precautions (e.g. regularly updating your software) is likely to reduce your exposure. If however, an attacker has taken a specific interest in your affairs, they might go to great lengths to target exactly your vulnerabilities and take into account your specific preventive

measures. They will also consider a multi-stage approach rather than a single attack.

What are the capabilities and knowledge of your adversary?

This can be considered on both strategic and technical levels. Does the attacker control resources you rely on (e.g. hardware, software, infrastructure, environment, communication partners)? State actors are bound to have wider capacities than small-scale criminals.

What are your security goals?

What do you want to protect, which aspect needs protecting (e.g. privacy) and against whom? How are your safeguards interconnected? Does the compromising of one element give the adversary new capabilities? Can a secret be inferred by looking at other data items (including metadata) – in digital or in real life?

Any such threat analysis must be tailored to your needs. It may lead to conclusions conflicting with best practice checklists (e.g. if you determine that a relevant state actor exerts power over software you would otherwise use as a safeguard against other attackers). In these cases, you have to consider legal implications as an additional factor. However, be aware that any generic checklist is bound to fail in the presence of capable and dedicated attackers.

Practical advice

In terms of how to approach cybersecurity, follow the practical advice below.

- Inform yourself about relevant national and institutional security authorities and ways you need to interact with them (to prevent and respond to security incidents). Note their point of contact (PoC) details and working hours.
- Review national and institutional regulations, recommendations and best practices. Ask for information about the current threat situation and assess how it relates to your specific situation. Discuss any doubts with your security PoCs.
- Make conscious choices about where to yield and where to retain control. Any automation (e.g. automatically opening inserted media or running embedded scripts in websites) represents a delegation of trust to external entities, which may or may not take your situation into account. Forcing yourself to manually enable processing on a case-by-case basis will increase your knowledge of what is happening.
- Segment domains wherever you can. If you use dedicated means to keep your work and private life apart, or to handle different classification levels, you will reduce the overall damage when being compromised. Be aware that any software that separates domains (e.g. virtualisation) is bound to contain bugs, so any

separation cannot be considered impenetrable. Check whether your employer can provide you with dedicated work infrastructure.

- Think before you act. When interacting with the digital world, consider not only the software or hardware you directly use, but also consider context: one programme runs alongside other programmes on your device, communication happens over a (probably insecure) communication infrastructure, and you are always surrounded by an environment.
- Do not consider any data as a stand-alone entity. Combining and interpreting fragmented data sets ('big data') is now commonplace. Even metadata (e.g. a GPS stamp on a published photo or a network address associated to an instant messenger message) carries information that can be interpreted.

Encryption

When handling data and IT, consider the following key points below.

- Encrypt any data storage carried out of secure premises or left alone, as well as communication via insecure networks.
- Support state of the art encryption. Ciphers (encryption methods) can become obsolete, so take advice from your security PoCs.
- If possible, disable weak cipher suites. Many secure communication protocols comprise a cipher negotiation between endpoints and have their own vulnerabilities. If a bad cipher is chosen, communication can easily be compromised. If you cannot disable weak cipher suites, do not fully trust the communication channel.
- Choose strong passphrases. Passphrases are commonly used to protect encryption keys (similar to a padlock PIN for a key safe). The encryption key may comprise 256 random bits, but if the passphrase that protects it is a single real word with eight letters, the latter will be attacked rather than the actual encryption key.

Passwords

The rules governing strong passwords have changed several times over recent decades, by learning from common mistakes. Guessing passwords is all about combinatorics and heuristics. Words reduce the combinatorial complexity and can be attacked using dictionaries. Given time, any password can be guessed, so changing passwords and using individual passwords for different systems makes sense. However, with an ever-increasing number of constantly changing passphrases, there is a dangerous tendency to write down what should remain a secret. Consequently the latest advice is to create passphrases out of nonsensical but mnemonic (easy-to-remember) sentences of actual words with minor modifications. The re-use of passwords for different systems obviously creates a dependency between these systems, which is why this practice is strongly discouraged. Password managers facilitate the use of a set of complicated passwords unique to each system at the price of an added dependency on the software quality of the password manager itself, as well as the security of the environment in which it is running. Again, you should consult regulations and reflect on your situation.

Backups

It is vital to ensure your data is always available through backups, especially if you suffer from a ransomware attack. Follow the advice below on backups.

- Make frequent backups of changes (incremental backup) and keep several previous backups in parallel (rotating backups). This will help to limit the impact of sudden data loss.
- Less frequently, create complete snapshots (duplication of entire storage repositories) of your devices (e.g. a system recovery backup).
- Periodically test whether your backups are working and whether you are able to reinstate the latest backup.
- Store copies in geographically separate locations.
- Be wary of cloud storage. The administrator of any infrastructure is always able to access data on his own devices. But if data is encrypted and decrypted on the cloud, the encryption keys are present (and therefore possibly accessible) on the cloud as well. Encryption is essential for all relevant data, but equally essential is where the encryption is taking place! If the software used for encryption is under the direct control of the cloud provider, that raises additional concerns.

Security incidents

When encountering a cybersecurity incident, think about limiting the damage to others and facilitating forensics. Try and carry out the actions below.

- Immediately contact your security PoC to inform them and ask for instructions.
- Quarantine your affected devices – including those known to be affected or previously interconnected – unless instructed otherwise (e.g. in order to observe an attack in progress).
- Preserve the state of your devices for forensic purposes. If possible, do not change anything in their configuration, until forensic investigations are over. If you have no choice but to reinstate the device as soon as possible, try to create a snapshot on a storage device specifically procured for this sole purpose.
- When reinstating a backup, consider how far back into the past you need to go in order to trust it.

At your residence, at work and during recreational time

On mission, daily life and work may be very different from what you are used to at home. This section gives you basic safety instructions and advice on infrastructure at your residence and at work, as well as on how to behave during recreational time.

Residential safety and security

There are some important matters to take into consideration when choosing a residence.

Choose a safe neighbourhood to move to. Make sure the access routes to and from your residence provide alternatives and avoid dead-end or narrow, one-way streets. Check out the parking possibilities (e.g. carports and driveways within fenced or guarded areas). An apartment, especially one above the second floor, presents a more difficult target for criminal intrusion than a house and provides the tenant some degree of anonymity. Perimeter security (e.g. a fence or security guards) can improve the safety of your residence, as can solid doors, grilles on the windows, secure locks, an alarm system, adequate fire safety, emergency exits and safe rooms (if needed).

When you first move into a house or start working in a new environment, use your initiative and common sense to

identify hazards. For example, look out for exposed electrical wiring, windows without mosquito mesh, areas where it is easy to slip or fall, hazards from unlabelled bottles or substances, or containers handy for water storage which may have contained pesticides or may be breeding grounds for mosquitoes. Be aware of fire hazards such as open stoves, open fires or cooking pans, and the use of charcoal fires without adequate ventilation.

Make sure that the owner of your apartment or house is legitimate and that you have the proper legal paperwork to rent the place. In general, the security section of your mission should be consulted during the process of selecting your residence. A specialist engineer should be consulted when selecting accommodation in an earthquake-prone environment.

Recreational time

These rules are obvious, but all too easy to brush aside when other things seem more important. Having survived the mud and potholes on mission, take care during your leisure time. At the seaside, be aware of dangerous currents, undertow or rip-tides, and areas known to have jellyfish, crocodiles or sharks. Stay within your depth unless you are a strong swimmer. Use life jackets for offshore water sports or when using inflatable craft. Never run along the side of a slippery pool; never dive into cloudy water or into a pool of unknown depth. Do not drink alcohol before swimming

or diving. And remember – heavy drinking brings many risks ranging from killing yourself or your friends in a road accident to contracting HIV because you forgot to take the necessary precautions.











Fire safety

By Gerard Guerin

Fire extinguishers

Make sure you are familiar with whatever types of fire extinguishers you are provided with and how to use them. If possible, you should also have access to a fire blanket.

The five main types of fire extinguisher and the types of fire they can be used on are displayed in figure 5.1 below.

Types of Fire Extinguisher						
		Water	Foam Spray	ABC Powder	Carbon Dioxide	Wet Chemical
A	 Wood, paper and textiles	✓	✓	✓	✗	✓
B	 Flammable liquids	✗	✓	✓	✓	✗
C	 Flammable gases	✗	✗	✓	✗	✗
-	 Electrical	✗	✗	✓	✓	✗
F	 Cooking oils and fats	✗	✗	✗	✗	✓

Remember:
Never put water onto boiling oil. It will explode!

Actions in the event of fire

In the event that someone catches fire:

- stop, drop and roll them over;
- cover them with a fire blanket, damp sheet or other material;
- try to smother the fire.

In the event of a small fire in a building or vehicle:

- use your fire extinguisher or fire blanket;
- keep your escape route to your back – never let a fire get between you and your exit;
- if one extinguisher does not put the fire out, get out;
- if in doubt, get out;
- call the local emergency services;
- assemble at your designated assembly point.

In the event of a large fire in a building or vehicle:

- keep yourself and others well back from the fire;
- remember: cylinders and compressed gases can explode in a fire and have been known to travel more than 200 metres;
- never re-enter a burning building.

Fire exits

- make sure you are familiar with your environment;
- know your escape routes;
- have an escape plan.

Fire safety

- nominate a fire warden to take charge in case of fire;
- carry out routine fire safety walks if the building does not have a fire alarm;
- regularly check for fire dangers;
- if you smell smoke, investigate and evacuate;
- if you smell gas, open all windows, ventilate and evacuate;
- agree on an assembly point with your colleagues – a location everyone goes to in the event of an evacuation or emergency;
- know how to call the local emergency services;
- know your address or your location;

- if possible, place battery-operated smoke alarms on escape routes and in bedrooms or dormitories.

At night

- check for fire dangers before you go to sleep;
- re-check your escape route.

On the road

Road safety

Road accidents are more likely to harm you than any other incident on mission. For this reason, it is important that you keep the advice below in mind at all times.

- Never drive after drinking alcohol or taking drugs.
- Never drive beyond your capabilities or in dangerous road conditions.
- Get a good night's rest before any long journey. Take regular breaks (every two hours if possible).
- Drive with a companion and share the driving when covering long distances.
- Avoid travelling in the dark. Ensure that all timings on your route plan enable you to reach the destination before nightfall.
- Maintain a sensible speed, even if you have an urgent appointment.
- Always wear a safety belt.
- Ensure any vehicle you use is well maintained and regularly serviced.
- Select and train any drivers you use with care and thoroughness.

- Before taking a trip, familiarise yourself with the appropriate behaviour in case of an accident in your specific mission context.
- Keep a first aid kit, gloves and a torch with spare batteries in the vehicle.
- Always know the phone numbers for the local emergency services and for the relevant mission personnel.
- Wear a crash helmet if riding a motorbike.

Checkpoints and road blocks

Checkpoints and road blocks are quite similar: a manned position on the road designed to monitor and control movement in a particular area. Checkpoints can be operated by legitimate authorities as legal checkpoints (e.g. police or military) or by illegitimate individuals or groups as illegal road blocks, often set up by local gangs to extort money from passing civilians. When you move into a new area you can expect to be stopped at these control points. As you gain more experience and credibility with the group manning the barrier, you may be allowed to pass unchecked. Never rely on this, however, and always be prepared to stop.

Some checkpoints are well constructed and established for long-term use with sandbagged bunkers, a tent or rest areas, and a clearly visible and raisable barrier across the road. They may well have mines placed across the road for added security. In other cases, you may simply encounter a tree or even a branch pulled across the road, with one or

two persons plying their new-found, lucrative trade as toll collectors.

So how do you deal with checkpoints and road blocks? The following information and advice is valid for legal checkpoints. When approaching illegal checkpoints, consider the advice below, but use your common sense.

- Do not approach a checkpoint that appears to be out of place or hostile. Consider asking your local staff or drivers for their opinion.
- At night, dim your headlights well in advance of the checkpoint so as not to blind the personnel working at the checkpoint. Switch on your inside light so that those inside the vehicle can be seen not to pose a threat. Ensure that any light mounted on top or at the back of your vehicle to illuminate your flag or logo is turned on.
- As you approach a checkpoint, inform your base, slow down, lower the volume of your radio speaker and make no transmissions. Using your communications equipment could raise suspicions.
- Turn off any music. Take your sunglasses off. Keep your hands visible.
- Obey any signs or instructions to pull in or stop.
- Be polite, friendly and confident. You should not talk too much, offer cigarettes, etc. This might suggest that

you are afraid and could be exploited by the road block personnel.

- Do not open any doors or windows until you are satisfied that it is safe to do so.
- Show your ID card if requested. Explain in a friendly way, if asked, where you are going.
- Prepare a short summary of your organisation's work, but keep it short.
- In case they insist on checking your vehicle, let them do so.
- Do not be in a rush to continue your journey. Be aware that the road block personnel might be keen to talk or offer advice to you. You could also ask them for useful information on the route ahead or your eventual destination.
- Avoid temptation by ensuring that there are no attractive items such as electronics, sweets, chewing gum or cigarettes visible from the window. Avoid wearing expensive watches.
- Pass through checkpoints one vehicle at a time, maintaining visibility of any other vehicles in your convoy.
- When you leave the checkpoint, contact your base (watchkeepers).
- At illegal checkpoints run by free agents rather than clearly identifiable legitimate personnel, it might be worthwhile stopping before the block itself if you possibly can. Just wait for a while and observe. Is other

traffic passing through the road block? How are the occupants of the vehicles being treated as they pass through?

- You could wait for an oncoming vehicle (i.e. one that has passed through the road block) and ask them for advice on whether it is safe to proceed yourself. You could ask your local staff or drivers for their opinion on whether it is safe to proceed. If it does not feel safe, turn back.

Ambush

An ambush is an attack by assailants in a concealed position. It is an extremely dangerous, life-threatening situation. Avoid travelling in areas where a threat of ambush exists. In most cases, ambushes are deliberate operations, carefully planned and coordinated. Take the precautions below to reduce the risk of being ambushed.

- Avoid travelling close to vehicles that might be targets (e.g. food convoys).
- Avoid travelling at night.
- Avoid routines and predictable patterns of operation where possible.
- If travelling is absolutely necessary, try to travel in a convoy and listen to road safety information from credible sources (if available).

- Consider the use of an armoured vehicle where necessary and wear protective gear or have it available for use.
- If you encounter a deliberate obstacle or a road block and you have time to stop in advance, do so and assess the situation. Withdraw if necessary or if in doubt. A professional ambush will be situated at a sharp bend in the road or just over the brow of a hill, so that you have no warning. Keep your base (watchkeepers) informed of your movements.
- Be aware of the 'ground', especially in high risk areas. Always strive to note possible escape routes by vehicle or on foot. Ask yourself what would be likely terrain for an ambush.

How to react if caught in an ambush?

If you are caught in a deliberate ambush, you are in an extremely dangerous situation. Your options might be limited.

- Stay calm, think quickly, use your common sense.
- You might want to accelerate and race through the ambush site, or reverse, if at all possible. Reversing might be too slow to get away and racing through might not be an option if the road is blocked.
- Do not do anything that could exacerbate the situation further.
- In case you cannot get away, follow the instructions given by the personnel who have ambushed you.

- If possible, call for help and inform your mission headquarters of your location and the incident.

Individual protective gear

The flak jacket

If you receive a flak jacket, familiarise yourself with the jacket before you have to use it. It provides a low level of protection for the chest, back and neck against the effects of blast, shrapnel and splinters of glass, wood, etc. It is not designed to stop a bullet. It is comfortable, light to wear and should be used in conjunction with a helmet.

The ballistic jacket

Ballistic (bullet proof) jackets offer varying levels of protection. The best can give protection against all known rifle and pistol rounds up to 7.62 mm. They are expensive and only designed to protect certain parts of the body. Additional neck and groin protection options are available. They can come with a large front pocket for your ID cards and first aid pressure bandages. With high levels of protection comes weight (up to 12 kg). At first you will find them very difficult to wear, but you will soon become accustomed to them. There are male and female versions. Make sure that you have the correct version and size, and that you are familiar with the protection level and correct usage. Tips on using the ballistic jacket are below.

- The back and front collar options, which can be opened and closed, give added protection to your neck and throat.
- Always check to make sure that the ballistic plates are in place. They can be easily removed. One plate is normally curved and should be placed in the front compartment of the jacket.
- The jacket and other safety items are very expensive. You will need to take care of them as best as you can. They are extremely attractive items for thieves.
- The ballistic jacket can save your life. Make sure that it is fully functional and protected from damage or theft.

The helmet

Helmets are designed to protect the most vulnerable part of the body from blast and shrapnel. They are not normally designed to stop a direct hit from a bullet. Tips on using the helmet are below.

- The helmet is worn in high-risk areas where flak and ballistic jackets are used.
- Always ensure that the neck strap is securely fastened. Otherwise a jolt will send the helmet flying off your head just when you need it most.
- The helmet takes time to put on and fasten, so do not wait until it is too late.

- Open the windows of your vehicle a little when wearing the helmet. It restricts your hearing and, with the windows shut, you might not hear the warning sounds of danger.
- Be aware!

Weapons

Positions occupied by personnel with police or military backgrounds can require the carrying of weapons. If that is the case, carefully check the details with the mission you are deployed to.

The handling of weapons by civilian crisis managers is not only unnecessarily dangerous, it can irretrievably undermine the image of the mission. This applies whether you use a weapon, possess it or simply pose with it.

Unauthorised possession or carrying of weapons of any kind is a no-go for civilian personnel.

Mines and explosive hazards

By Thomas Enke

When deployed on a crisis management mission, you may be confronted with mines or explosive hazards in different ways. Mines or minefields can be leftovers from an earlier conflict. Mines or improvised explosive devices (IEDs) are used, for example, to protect property, to pose a threat or even to attack an enemy. This section provides basic information on mines, IEDs, unexploded ordnance (UXO), explosive remnants of war (ERW) as well as booby traps and offers basic advice on dealing with these threats.

There are two types of mines that you need to watch out for: anti-personnel mines (APMs) and anti-vehicle mines (AVMs).

Anti-personnel mines

APMs are designed to cause injury to people rather than to equipment. They might be laid in conjunction with anti-vehicle mines or by themselves. APMs are grouped into three different munition sorts: blast, fragmentation and small shaped-charge mines.

Most APMs will be triggered when put under pressure, but one or more tripwires attached to fuses can also trigger the device. The lethal radius of these mines depends on the type and the amount of explosives. Some APMs have

a lethal radius of about 50m. Most APMs are coloured green or black.

Blast mines

Blast APMs were formerly made of metal or wood, but now are often made of polymer. They are either cylindrical in shape, with a diameter of about 7 cm to 16 cm, or rectangular, measuring around 10 cm x 20 cm long and 5 cm to 10 cm high. The mine explodes when the victim steps on the fuse and the concentrated blast of the explosives causes death or serious injuries.

Fragmentation mines

Fragmentation APMs include stake mines, directional fragmentation mines and bounding fragmentation mines. Over the years, mines become rusty and will be hard to find. Stakes and trees can be broken, vegetation will grow over tripwires. So the best advice is to stay out of areas with a possible threat of mines.

Stake mines are fitted to wooden or metal stakes hammered into the ground until the mine is fixed at a height of about 20 cm above the surface. The fuse will usually be triggered by pulling a tripwire, which is made from very fine metal or nylon wire and is hard to see. The fragmentation shrapnel will blast in all directions over a large distance and lead to death or serious injuries.

Directional fragmentation mines, also called Claymore mines, use an electrical fuse and will be triggered by the victim stepping on a piezoelectric sensor or by a triggerman closing an electrical circuit using a command wire. The fragments will be projected through an angle of about 60° and will cause death or serious injuries up to a range of about 50m. These mines are often attached to a tree or tripod at a height of about 50 cm.

Bounding fragmentation mines are normally buried. The mine is integrated in a small tube like a mortar. The fuse can be triggered by stepping on it or with a tripwire. Once triggered, a small charge pushes the mine out of the tube. At a defined height, around 1m, the mine explodes and the fragments spread out in 360° . The typical deadly radius will be about 25 m or more.

Shaped-charge mines

APMs with a shaped charge are very small, generally buried and painted in different mainly dark colours. They have a diameter of about 5 cm and a length of 12 cm. The fuse is operated by the victim stepping on it. An APM with a shaped charge is not designed to kill the victim. A small amount of explosives fires a shaped charge through the shoe, the ankle into the knee. Heavy pain, amputation of the leg above the knee and long-term treatment are the results.

Anti-vehicle mines (AVMs)

AVMs, also referred to as anti-tank mines, are designed to disable vehicles. They are normally laid in fairly large numbers to achieve their aim. In an active conflict zone you can be fairly sure that mines of this type will be kept under observation. They are valuable weapons and are protecting valuable routes or objectives.

Do not go too close to such mines. And, obviously, never touch them for any reason. In areas where fighting has ceased, the mines may remain in place though their guardians are long gone. Nevertheless, you should not yield to the temptation to interfere with them.

Some important features of AVMs are as follows:

- much larger than APMs, with a diameter / length of up to 30 cm and a height of up to 11 cm;
- square or round in shape;
- made of plastic or metal;
- coloured the same as APMs, i.e. dark, camouflaged;
- detonated by the pressure of a vehicle passing over them (remember, your vehicle is heavy!).

Occasionally AVMs are detonated by a tilt rod sticking out from the top of the mine, which is sometimes attached to tripwires. Just as these mines are normally kept under observation, they are also further protected by APMs in the

surrounded area – another good reason to keep away from them. Bad weather conditions such as heavy rainfall could flush the mines out of (marked) dangerous areas. Furthermore, insurgents or other militant groups can use mines to close paths and roads. It is therefore important to drive only on paved roads and not to leave them for any reason.

IEDs / UXO / ERW

Improvised explosive devices (IEDs)

IEDs are essentially home-made, non-standard devices. They are usually fabricated from readily available raw materials. Most IEDs incorporate military, civilian or homemade explosives. Chemical, biological, radiological and nuclear (CBRN) agents are also possible. IEDs are produced in different sizes and forms, from a ‘letter bomb’ up to heavy trucks with five tonnes of explosives.

Unexploded ordnance (UXO)

UXO refers to all types of explosive ordnance (ammunition) that did not explode when it was used and therefore still poses a risk of detonation. This can include all types of explosive weapons, such as bombs, bullets, shells or grenades. All UXO should be treated with extreme caution: if ammunition has been fired, it can be in a very unstable state and still pose a risk of detonation!

UXO includes unexploded submunitions and bomblets, for example undetonated cluster bombs, warheads of artillery rockets and artillery rounds. These weapons can have a high failure rate of up to 50% in vegetated and urban areas, leading to a huge amount of UXO. A submunition can be an APM, a high-explosive anti-tank (HEAT) bomblet or a small bomb with different fillers. Submunitions come in a variety of shapes, colours and dimensions. Particularly dangerous are APMs in the shape of a butterfly or a dragon's tooth. Children pick up these mines, because they look like toys.

Explosive Remnants of War (ERW)

ERW are all the ordnance that remains after an armed conflict. This includes unexploded ordnance in abandoned stockpiles, military vehicles and facilities. In some cases these areas will be secured with mines and booby traps. Abandoned vehicles could be damaged with projectiles containing depleted uranium. This heavy metal is toxic and leads to serious diseases.

Dealing with threats from mines, IEDs, UXO and ERW

Now that you have some idea of what mines and explosive hazards are and what they look like, how should you deal with them?

- Contact the local Mine Action Centre or your mission's security officer for information on mine threats in your specific mission area.

- Do not touch any mine / IED / UXO / ERW or any unknown object – stay well clear of it. If you did not put it down, never pick it up.
- Resist helping attacked people. Further IEDs directed at assisting passengers might be lying around (standard repertoire of terrorists) and need to be taken carefully into account.
- Do not use your radio, mobile phone or SATCOM in close proximity (within 100 metres) of a mine unless absolutely necessary. The radio frequency you are using might cause the mine to detonate. This applies to all such devices: booby traps, mines, IEDs and UXO.
- If you come across mines / IEDs / UXO / ERW inform responsible organisations and local people of the mines' locations.
- Always seek local advice if moving into a new area or one that has been the scene of recent fighting.
- You should not use a route that is new to you unless you are certain others have used it recently. Try not to be the first to use a road in the morning.
- Remember, mines, IEDs and booby traps can be attached to tripwires. Do not even attempt a closer look.
- If you are in the lead vehicle and you spot mines, stop immediately and inform the following vehicle.

- Do not try to turn your vehicle around, do not leave the paved road. Do not get out of your vehicle. Try to drive backwards slowly along the same track you came along.
- Do not be tempted to move onto the verge of the road to bypass obvious mines, to get past some other obstacle or even to allow another vehicle through. A natural reaction at home might well be to pull over on a difficult or narrow road to let a fellow traveller get by. In mined areas, forget it! You should not be polite and pull onto the verge. The verges may contain mines. If necessary, reverse back to a wider area and let the other vehicle pass.
- If a road is obviously blocked by something (for example, a tree or a vehicle) in a likely mined area, do not be tempted to drive onto the verge or hard shoulder to get by. It could contain mines. Turn back.
- Avoid dangerous areas, such as old front-line positions, barricades, deserted houses in battle zones, attractive areas in deserted villages or towns, country tracks, gardens and cultivated areas (mines may be laid in tempting orchards, vineyards or vegetable plots).
- Make sure you understand local mine-awareness signage and be alert to the presence of uncollected, dead livestock or uncultivated land which may indicate the presence of mines.
- Make use of the 5 / 25 m check in unsafe areas or after attacks. For a short halt, passengers have to clear 5 metres around the vehicle. For extended halts, an area

of 25 metres around the vehicle has to be cleared. For more information on how to do this, refer to Annex A3 of the *Landmines, Explosive Remnants of War and IED Safety Handbook* (UN Mine Action Service, 2015).

- Electronic counter measures, particularly ‘jammers’ can, depending on the location and context, protect you from radio-controlled IEDs.
- Be on your guard against ‘cleared areas’. An area might be declared to be clear of mines, but you cannot be 100% certain.
- Remember, if you identify a mined area or are informed of one, spread the news. Record the information and mark it on your maps.

Actions in a minefield (MINED):

Movement stops immediately.

Inform and warn people around you.
If you can, contact your base for help, indicating where you are located.

Note the area. Examine the ground to ensure you are safe where you are, look for tripwires/mines/fuses.

Evaluate the situation.
Be prepared to take control.

Do not move from your location.
Wait for help.

When assisting a victim in a minefield, the rescue options are very limited.

- Stay calm and breath deeply.
- Do NOT run to the victim.
- Do NOT try to rescue the victim in a suspected minefield or unsecured area.
- If possible talk to the victim and calm them down.
- Advise the victim not to move, because help is on the way. Advise them to self-administer first aid.

- Call for help and use the 9-liner MEDEVAC request (see below).
- Wait for the rescue team to arrive.

Avoid booby traps!

A booby trap is an outwardly harmless object designed or adapted to kill or injure by exploding unexpectedly when a person disturbs or approaches it. A booby trap can be triggered when you perform an apparently safe act with it (e.g. opening a letter or a door, picking up an attractive article lying on the ground). The device is deliberately disguised as, or hidden inside, a harmless object.

Withdrawing troops may place booby traps in all sorts of places so as to inflict damage on their advancing adversaries. Booby traps may be left on paths, by wells, in houses or just lying in the open and attached to an appealing object.

Do not explore deserted houses, towns or villages. You should not be tempted to snoop around or use empty houses to 'answer the call of nature'. Most importantly, do not touch apparently interesting objects lying innocently on the ground. Just leave them alone.

After-explosion procedures

An explosion can have many causes. If you notice an explosion in your immediate vicinity and don't know the cause, it is mandatory to secure yourself immediately. Use the 5 / 25 m check to establish a safe environment. Then follow the five C's:

CONFIRM

Clarify the situation from your safe position. Don't move.

CLEAR

If you think your position is not safe, you have to increase your distance from the explosion – using cover.

CALL

appropriate authorities, mostly police or army.
If known, use the 9-liner format.

CORDON

the area by warning other people not to enter the vicinity of the explosion.

CONTROL

the area until police or army and rescue teams reach the site.

Important:

- Do NOT enter the vicinity of the explosion.
- Do NOT touch any thrown objects, such as fragments of ammunition, IEDs or the target.
- Take a mental note of what you see and inform the appropriate authorities.

9-liner MEDEVAC request

Calling in a helicopter MEDEVAC during an emergency requires passing concise information rapidly by radio. NATO forces use a 9-liner system, so called because of the 9 lines of information it includes:

Line 1: Location of the pick-up site

Line 2: Radio frequency & call sign

Line 3: Number of patients by priority:

- A – urgent (1hr)
 - B – priority (4hr)
 - C – routine (24hr)
-

Line 4: Special equipment required:

- A – none
 - B – hoist / winch
 - C – extraction equipment
 - D – ventilator
-

Line 5: Number of patients by type:

- L – litter
 - A – ambulatory
 - E – escort (women / children)
-

Line 6: Security at pick-up site (in peacetime – number of wounds, injuries and illnesses)

- N – no enemy
- B – coalition / civilian
- C – non-coalition security force
- X – armed escort required

Line 7: Pick-up site marking:

- A – panel
 - B – pyrotechnic signal
 - C – smoke signal
 - D – none
 - E – other
-

Line 8: Patient nationality and status:

- A – coalition forces
 - B – coalition civilian
 - C – non-coalition security force
 - D – non-coalition civilian
-

Line 9: NBC contamination (in peacetime – terrain description of pick-up site):

- N – nuclear
- B – biological
- C – chemical

To initiate the MEDEVAC, you need communicate only the first 5 lines – you can pass on the remainder while the helicopter is in the air. Aim to speak for no more than 30 seconds and leave a pause between each line to allow the duty officer at the other end to note down the information. 9-liner formats vary – check the correct format used in your environment.



Chapter 6

How to cope with everyday reality in the field*

The moment you decide to deploy overseas into a health emergency situation, you are automatically signing up for a whole range of responsibilities that come with working in an international team. Apart from delivering on your contract and job description, there are many more subtle aspects of responding to an emergency in someone else's country.

Embarking on a mission means that you agree to uphold your own professional standards and your organisation's code of conduct. The way you carry out your tasks and the way you communicate your work will affect your organisation's reputation and its ability to operate.

Equally important, though, is how you behave outside the office and in your down-time. You will find yourself in a foreign environment whose social and cultural norms may be very different from your own. You will be working with

* For full credits, references and further reading on the subjects covered in this Chapter, please refer to Credits & References Chapter 6 on p. 573

colleagues from diverse backgrounds and encountering unfamiliar organisational cultures. Soft skills – such as respecting your hosts' culture, learning some of their language and taking the time to build their trust – may prove as valuable in achieving your mission as your professional qualifications.

Procedures and codes of conduct

By Emilio Hornsey

Professional registration

If you are registered as a medical, nursing or allied professional in your own country you must always abide by your code of conduct and requirements even while you are working overseas.

Where a national or local professional registration is required in the country you are working in, this should always be in place before you begin to practise or deliver any care. This may be arranged on your behalf by your deploying organisation or if you are working as part of an official Emergency Medical Team (EMT). It should never be assumed that an honorary contract or other locally agreed engagement (voluntary or paid) means that professional registration and the right to practise are in place.

If there is no system for registration of health professionals where you are practising, then you should always work within your scope of practice and in line with your domestic code of conduct. In addition to professional registration for clinicians, all personnel should abide by their organisations' codes of conduct.

Principles of informed consent should always be followed. Where these systems are not formally developed, the health worker should adopt a thorough and humane procedure to ensure informed consent in all circumstances. This should include provision for patients with differing literacy and language abilities.

It may be necessary to adapt the delivery of care in line with local resources and pressures. However, this should always be based on the principle of providing the best standard of care that is practically possible. Any temptation to automatically lower standards in unfamiliar settings should be resisted.

You may encounter situations for which your training has not fully prepared you. These can be ethically challenging and even morally injurious without adequate preparation and a deep understanding of the responsibilities and limitations of your role.

SOPs and classification of medical teams

Standard Operating Procedures (SOPs)

SOPs define a comprehensive list of steps to perform a task or process. The International Conference on Harmonisation (ICH) describes them as ‘detailed, written instructions to

achieve uniformity of the performance of a specific function.’ They differ from guidelines or policy, which are developed systematically to provide broader strategic direction or assist decision-making. SOPs should be evidence-based, unequivocal and rigorously applied. They are especially valuable in safety-critical situations.

SOPs provide EMT members with a common framework that improves efficiency. EMT staff will often be drawn from different organisations and will be used to different structures, equipment and pathways. SOPs can therefore be invaluable in improving communication and functionality for both junior and senior staff. They can minimise some of the variation in practices and outcomes. However, not all clinical or healthcare activity can be defined in an SOP – they are only one part of a thorough and systematic approach to quality improvement.

SOPs should be established along with training, supervision and provision of the resources needed to follow them. Compliance is monitored by a full and ongoing cycle of audit, using observation, ongoing training and reflection.

SOPs should use clear, precise language and images where necessary. They should be developed with the audience in mind, kept readily available at the point of use (i.e. on multiple formats) and reviewed frequently.

SOPs should be prepared, approved and practised prior to deployment. They should be subjected to ongoing

review during deployment and adapted to take into account new team members, partners and context-specific circumstances.

SOPs have many functions – they can:

- define an optimised process of care;
- support implementation of evidence-based medicine;
- improve interoperability and integration between EMTs;
- integrate quality assurance into clinical care;
- improve transparency;
- improve induction of new team members;
- improve quality of clinical education; and
- protect health workers from malpractice.

Examples of internationally recognised SOPs include the *WHO Surgical Safety Checklist* and the ‘Sepsis Six’ tool.

Classification of Emergency Medical Teams

Emergency Medical Teams (EMTs) are groups of health workers (e.g. doctors, nurses, paramedics) that treat people affected by an emergency or disaster. They come from governments, NGOs, military forces and international organisations such as UN agencies and the International Red Cross and Red Crescent Movement.

WHO has developed a global registration system to verify and classify EMTs before deployment and to set minimum standards for such teams. The system serves as a deployment and coordination mechanism for all partners who aim to provide clinical care in emergencies and allows an affected country to call on teams that have been pre-registered and quality-assured.

The EMT classification is largely comparable to the NATO echelons of medical care and allows a degree of mutual interoperability between civilian and military medical teams. Some major emergency health actors have not sought classification within the EMT system but maintain their own organisational structure.

EMTs can be international or national teams, but they should strive to be self-sufficient so as not to burden national or local health systems. They may specialise in particular areas, for example trauma, spinal injury care, rehab or outbreak response and public health.

As a minimum, all EMTs should:

- be licenced to practise in their country of origin;
- be specialists in their field;
- have suitable malpractice insurance;
- be registered and licensed with national authorities and the lead international agency;
- declare skills and services provided;

- report regularly during the response;
- maintain confidential patient records and arrange referral plans;
- collaborate with the existing health system and be self-sufficient;
- ensure supplies and medications meet international standards;
- maintain standards for hygiene, sanitation and medical waste management;
- care for team members' health and safety, and repatriation if required.

For more information on EMTs, see Chapter 1.

Codes of conduct and ethical principles

Representing your organisation, 24 hours a day

While on mission, you must remain aware that your conduct is subject to continuous scrutiny by both local and international observers. Since you will be representing your organisation and reflecting its image 24 hours a day, you will often feel overwhelmed by a multitude of expectations, most of which will be based on universally recognised international legal norms and disciplinary regulations that you might not have been familiar with before going on mission. Therefore, before you rush into action and end

up tainting your reputation and that of your organisation, you should read, understand and abide by the staff code of conduct and ethical principles.

Your organisation's code of conduct is designed to guide you in upholding the highest standards of professionalism and morality when making decisions.

Below are some of the elements that you are bound to encounter in a code of conduct.

- You have a duty not to abuse the position of authority that you hold.
- Misconduct of any kind is unacceptable and will result in the imposition of disciplinary measures.
- Local laws and customs must be observed and respect shown for traditions, culture and religion.
- You must be impartial and diplomatic and treat people with respect and civility.
- Mission resources and money must be correctly accounted for in line with the organisation's policies and procedures.
- Most importantly, your organisation will have a zero-tolerance policy on exploitation and abuse. For more information on this subject, see Chapter 2.

Channels for complaint – the ombudsman

Over time, several mechanisms have been developed and used to probe and ensure that organisations and individuals act in an accountable manner. One of these mechanisms has been the use of an ombudsman.

Organisational ombudsmen are most often neutral personnel whose job is to mediate and resolve disputes or other work-related complications, while providing confidential and independent support as well as advice to employees or other stakeholders. The use of Ombudsmen offices is voluntary: they complement, but do not replace, formal channels. Informality is often an essential element, as it allows participants to explore a wide range of options across organisational boundaries. Ombudsmen are generally referred to as the ultimate ‘inside-outsiders’ and are known for handling employees’ complaints and grievances and guiding them in the right direction.

The European Ombudsman, for example, is an independent and impartial body that holds the EU administration to account. The EU Ombudsman investigates complaints about maladministration in EU institutions, bodies, offices and agencies. The UN General Assembly created the UN Ombudsman and Mediation Services (UNOMS) with responsibilities for UN staff and peacekeeping missions.

The ombudsman may find maladministration if an institution fails to respect fundamental rights, legal rules or

principles, or the principles of good administration. This covers, for example, administrative irregularities, unfairness, discrimination, abuse of power, failure to reply, refusal of information and unnecessary delay.

Therefore, if you ever witness (or fall victim to) any organisational misconduct, you should not hesitate to contact the ombudsman for advice and seek guidance on how to proceed with the violation at hand.

Managing communication and media relations

By Christian Lindmeier

Information or infodemic?

During the COVID-19 pandemic, the importance of correct, factual and scientific information became painfully clear. The amount of false information circulating could itself be declared an ‘infodemic’. While the motivations behind spreading false information can be wide-ranging and are not always malicious or commercially driven, the consequences are the same: people are confused, they are sometimes lied to and they have increasing difficulty identifying and trusting the right information sources.

Therefore, in whatever official capacity you are communicating in a health emergency, whether in a memo to colleagues, a report to a supervisor or donor, on social media, or in an interview, always make sure that you are representing the latest and best scientific information. Do not spread misinformation or rumours. Do not become part of the infodemic.

Personal communication

The mission you work in might have a policy on the personal use of blogs, Facebook, Twitter and other media in connection with mission activities. No mission member should make statements on social media or to the media on behalf of the mission unless they have received clearance to do so.

You should always be aware of identity thieves and fraudsters and think about your professional reputation and that of your mission. Some parts of the media might be looking out for a story about public officials that could be embarrassing.

It is important to remember that once you 'click', the information you have provided remains in the public domain – forever. You are not able to control what people do with that information and whether third parties can access it. Social networks such as Facebook can provide access to your personal information.

Some tips

- Keep official and private information separate.
- Keep privacy settings high and consult them regularly. Be wary of posting personal information and disclosing financial details.
- Do not hesitate to block or report someone who is making inappropriate comments or advances.
- Pictures: keep them for your friends and think about what could happen if they became public.
- Never post anything on social media in relation to an ongoing or future security incident. By doing so, you could endanger yourself or colleagues, or you might hamper ongoing investigations.
- Evaluate each post before posting: if you would be happy to see your post on the front page of tomorrow's newspaper, then go ahead. If not, you may want to reconsider.

Internal communication

Internal communication within a mission includes information gathering, dissemination and interactivity. Possible internal communication tools include the intranet, open days, internal billboarding and mission newsletters. Internal communication should ensure that the mission's mandate, main elements, achievements and milestones are clearly understood by every mission member. This information should be available in a format and wording that make it possible to share with non-mission members.

Consider providing information through internal communication, before you go public. Among other benefits, this has a trust-building effect with mission staff. All mission personnel should be aware of the current programmes being performed by the mission and of political, social and other factors in the host country that may affect the mission's endeavours. All mission staff are ambassadors of the mission and important multipliers of information.

Keep in mind that with all these tools and with a large number of staff within the mission, there is a strong likelihood that whatever is conveyed as internal communication will get out to the public. Sensitive issues or messages for purely internal consumption are better communicated in person.

Communicating in emergencies

Missions have both an obligation and a key self-interest in communicating frequently and transparently about their work. Communication and media relations should therefore be regarded as an opportunity, rather than a challenge. The key is to coordinate effectively with the members of your press and communication team. Everyone must know what their tasks are.

A simple procedure for communicating during emergencies should be established in advance. Transparency – as far as it is possible under safety and security considerations – builds trust and is an important foundation for public acceptance of the mission.

Managing relationships with the media and answering their queries requires trained staff. Whenever possible, refer requests for comments or information to the assigned staff or designated spokesperson in your mission.

Never say ‘no comment.’ Never speculate or lie. Give the basic information you have, offer to provide more details as soon as you have them and remember to do so. Focus on communicating facts and clarify them as best you can: who, what, when, where, why and how? Avoid a communication vacuum that lets rumours take the lead.

Use short sentences and simple words. Avoid jargon, acronyms, humour or judgmental expressions. Speak clearly and calmly. Try to transmit one idea per sentence.

When explaining or commenting on medical or scientific issues – consider yourself the interpreter between the science and the people. First understand what you are talking about and then do your best to explain it to the audience.

Ensure your body language matches your message. There are no ‘off-the-record’ comments. Assume that everything you share will be used in one way or another.

Media monitoring and rebuttals

A successfully working media monitoring operation is of crucial importance to the mission. Fast, accurate summarising of what is being reported in broadcast, print and online media is important for responding to public perceptions about the mission’s work. You should develop a keen awareness of the topics that are dominating the environment ‘out there’. This gives you the information you need to counter negative coverage and encourage positive coverage of the mission’s work.

Emergency management missions operate in environments where rumour and conspiracy theory are often the currency of public debate. False information can soon become ‘fact’. It is therefore important to respond quickly and energeti-

cally to inaccurate and sometimes malicious reporting about the work of the mission.

If the information you provide during a health emergency or pandemic is misrepresented, it may cause confusion in the population. Worse still, it may lead to dangerous behaviour, such as inadequate personal protection measures, wrong use of (fake) medicines and remedies, or xenophobia. In such situations, you should consider reacting and correcting this information as soon as possible.

Principles of rebuttal

- **Speed:** the mission must respond quickly to reports by wire services, because wire services provide news for other media outlets and have an immediate and multiplying effect.
- **Accuracy:** the mission must be 100% certain that it is right. The press and public information office should check and double-check its facts to make sure that the rebuttal is accurate and correct.
- **Proportionate response:** do you really need to respond? If you do, who should you be in touch with? How should you make contact (e.g. phone, email, meeting)? Should it be formal or informal? How strong should your language be?

Cultural sensitivity and diversity

Respecting your host culture

Health emergencies may bring together people from various professional fields who may not be used to working together, such as military officers and enlisted personnel from different services, NGOs of varying scope and size, international healthcare professionals, civil servants and diplomats, all of whom have different national, institutional and personal backgrounds.

In a mission, the situation is often complicated by the intersection of diverse organisational and national cultures. Missions bring heterogeneous personnel into contact with local people who often draw upon cultural backgrounds different from those of the operation and its staff. This increases the potential for culturally based misunderstandings and conflicts.

For example, you might find yourself having to deal with people and cultures whose basic speech patterns greatly differ from your own. In non-Western cultures, for instance, the use of indirect speech patterns when communicating with colleagues is prevalent. Some cultures are used to adopting very collectivist approaches (as opposed to the individualist ones you might be accustomed to) when it comes to work ethics and decision-making processes. In addition, while you might be used to static and strict work

rules, you will discover that some cultures embrace change and fluctuation as part of their everyday work and life.

In spite of all the frustrations that might result from dealing with foreign cultures, remember that missions are aimed at empowering people and should always draw on local capacity and culture instead of imposing foreign techniques and customs.

Unfortunately, missions often end up catering to the interests of the organisation and the operational culture of the crisis managers. This can significantly undermine the legitimacy of the deployed professionals and contribute to an image of responders as ‘occupiers’ or ‘colonialists’.

To avoid such insensitivities, you should try to build bridges of trust between yourself and your organisation on the one hand and the host community on the other. Reading anthropological and cultural guides about the different peoples you will be interacting with beforehand can help avoid misunderstandings and embarrassment. Equally, you must be aware of your own cultural background and its historical context. This is crucial because your nationality and country of origin may have a historical footprint of colonialism and occupation.

Cultural sensitivity is not only about learning another culture’s customs and history, it is also about learning and acquiring a deeper understanding of your own.

Building trust

- Tell the truth. Be honest. Exercise integrity. Let people know where you stand. Use simple language. Do not manipulate or spin the truth. Do not leave false impressions.
- Demonstrate respect. Note the importance of the little things. Genuinely care. Treat people with dignity. Take time. Listen.
- Create transparency.
- Right wrongs. Correct mistakes. Apologize quickly. Demonstrate humility.
- Deliver results. Establish a track record of getting the right things done. Make things happen. Do not over-promise and under-deliver. Do not make excuses for not delivering.
- Constantly improve. Be a learner. Develop feedback mechanisms. Act on feedback and appreciate it.
- Clarify expectations. Disclose expectations. Discuss them and validate them. Be realistic. Do not create expectations that you will not be able to meet. Do not assume that expectations are shared or clear.
- Listen before you speak. Understand. Listen with your ears, eyes and heart. Do not presume that you have all the answers or that you know what is best for others. Ask them. Demonstrate understanding and compassion.

Dress codes

Dress codes exist to help you ensure a level of decency and decorum and to present your image in a respectful way at all times. Your organisation might have its own specific dress codes, but what is appropriate depends on many factors, such as the country you are working in, the cultural and religious context, and whether you are a man or a woman.

Depending on the cultural and religious context, both men and women are advised to adopt modest and appropriate clothing, not only to show respect for local customs and culture, but also to avoid unnecessary attention.

Even if you do not agree with certain dress codes, always remember that you are a guest and you show respect or disrespect for your national partners and hosts through the way you dress. This also applies to remote field locations. If you meet local authorities or security forces, make sure you visit them wearing discreet and formal clothing.

If you have trouble deciding what clothes to wear, there are some general guidelines that you should follow below.

- Dress down, not up. This does not mean that you have to fake a scruffy and dirty look. But equally, don't wear flashy sunglasses, Gucci scarves and cashmere sweaters among locals who might be struggling to make ends meet. Parading your wealth will not make you

more popular or win admiration. If anything, it might make you a target for theft.

- Keep it simple.

Addressing the language barrier

Learning the local language

The ability to use the local language of the country or area you are deployed to can have a great impact on the operational outcomes of your mission. Of course, you are not expected to write a novel in a new language, but learning some basics and useful phrases before deployment, if time allows, will not hurt. It will be seen as an expression of cultural sensitivity and will reflect your interest in that culture and your respect for its people.

Working with an interpreter

No matter how advanced you judge yourself to be in the local language, employing an interpreter can prove indispensable in certain situations.

- During risky negotiations, highly complex meetings or when detailed and sensitive information is being passed around, it is recommended to resort to a professional and skilled interpreter who can convey the message with the needed level of accuracy and precision.
- If you find yourself under stress, your ability to express yourself in the local language might be hindered.

Employ an interpreter to help you out under such circumstances.

- Interpreters can also be your local specialists in public relations. They can often suggest the best ways to interact with people from different cultural backgrounds and can notice nuances that you might overlook as a non-local.

Finding the right interpreter

When interviewing translators and interpreters, you should try to keep the selection standards as high as possible. Remember that the quality of interpretation can have a big effect on your mission's image, expertise, efficiency as well as security. Some general prerequisites and criteria for effective interpreters are outlined below.

- **Language proficiency:** interpreters should be bilingual in both source and target languages. Make sure they undergo an oral test to assess their command of both languages and their interpretation skills.
- **Competency:** candidates should be able to work accurately and quickly. Interpreters should be trained public speakers who are able to understand meaning and tackle sophisticated linguistic problems quickly. Translators should be able to conduct thorough research and produce precise, 'camera-ready' documents within tight deadlines.

- **Neutrality:** you should attempt to find candidates who are locally engaged and unbiased in their judgments. This might be quite challenging, considering that locals could have been victims of direct or indirect violence and abuse, so they are likely to have psychological scars and problems that could affect their neutrality.

Forms of interpretation

There is more to interpretation than simply translating words. It is a matter of understanding the thoughts expressed in the source language and then paraphrasing them in a way that preserves the initial message using words from the target language. Different modes of interpretation are outlined below.

- **Consecutive interpretation:** this is usually performed during formal negotiations. The interpreter listens to the speech being made, takes notes and then reads out the main message to you after the person is done with a segment of the speech. Usually, the speaker stops every 1-5 minutes (at the end of a paragraph or a thought) to allow the interpreter to render what was said into the target language.
- **Simultaneous interpretation:** this is more challenging than consecutive interpretation. In simultaneous interpretation, the interpreter has to convey the message at the end of every sentence (or at least as soon as he understands the message of the speaker) while

simultaneously actively listening to and comprehending the next sentence.

- **Whispered interpretation:** here the interpreter whispers their translation to a person or small group.

Where possible, prepare meetings with your interpreter and discuss the purpose and expected outcome of the meeting. Gather information on the stakeholder or partner you are going to meet.

Make sure you are using terminology that can be easily understood and translated by your interpreter. If you have to use specialised terminology, check with your interpreter how they will explain this in the local language, especially if there is no direct translation for certain expressions or words.

Respecting the environment

By Emilia Wahlstrom

Climate change is recognised as one of the most serious challenges to the global community, affecting almost all aspects of life across the planet. With the world's increasing reliance on technology and diminishing resources, it is vital that every individual understands their impact on the environment. Although you might be working and living in a conflict area or country where disposal and recycling systems are not common, you should be aware of the mission policy on environmental impact.

The basic principles of environmental awareness by which you are expected to abide are below.

- **Reduce waste** and dispose of waste safely.
- **Reduce emissions** and pollution.
- **Use resources sparingly** (e.g. electricity, water, raw materials). Use renewable energy where possible.
- **Raise awareness!**

Reduce waste

In health emergencies, different types of waste will be generated which require proper disposal. While even the disposal of normal waste can be difficult in certain parts of the world, waste which is hazardous to public health and

the environment requires special attention. The improper disposal of waste, especially hazardous waste, may lead to pollution and contamination of the environment. Dangerous goods may be diverted to the black market for resale or misuse. Direct exposure to hazardous waste may also lead to acute health risks for staff and those that come into contact with it after disposal.

For this reason, adequate control measures should be put in place to minimise these hazards. Employers must take responsibility to protect not only their own employees, but also the environment, from hazards. Employees, meanwhile, have a responsibility to control and report potentially biohazardous situations and to adhere to safe procedures. All staff should follow minimum waste disposal standards, such as those provided by WHO and the Sphere Project. In addition, strategies for waste disposal and protection of staff and the environment should always be planned and implemented in adherence with local and national legislation, as well as in cooperation with the authorities. For more information on the safe disposal of medical and hazardous waste, see Chapter 3.

Colour-coding

- **Yellow:** laboratory waste, including blood;
- **Red:** oil, car batteries, medical waste (e.g. human tissue, contaminated material, bandages, tubing, drains, Porto-Vac, catheters, vaculiters, latex gloves);

- **Black:** normal household waste.

The three Rs of waste minimisation

Office procurement and waste minimisation should embrace the three Rs: **Reduce, Reuse, Recycle!** Although recycling measures require an off-site recycling system (which may not be in place in some countries), below is some advice for putting the three Rs into practice.

Reduce

- Avoid printing unless necessary and always print double-sided documents.
- Implement a paper-free electronic database for information storage and communication within your office.
- Avoid unnecessary packaging. Choose materials that can be recycled, where possible.

Reuse

- Reuse single-sided paper for draft copies or notepaper.
- Reuse folders, file clips and covers.
- Encourage staff to use reusable cups, crockery and cutlery for lunch and tea breaks to avoid unnecessary waste.

Recycle

- Construct a primary recycling station in a central location within the office.

- Every desk should have a paper-recycling box.
- Used printer toner cartridges can be recycled. Toner cartridges and electronic waste contain harmful chemicals that should not be placed in landfills.
- Explore options for local recycling and composting of food waste.

Reduce emissions

Most organisations encourage staff to reduce their environmental footprint in different ways, for example by avoiding unnecessary travel by conducting meetings online. Under certain circumstances, solar panels can be deployed as a power source in remote bases. Other ideas to reduce emissions are below.

- **Travel:** reduce travelling and support more efficient travel through a proper travel policy. Use environmentally friendly cars / trucks, trains and eco-driving techniques. Switch off vehicle engines when waiting, parked or stationary in traffic (unless doing so poses a security risk).
- **Buildings:** take active and passive measures to reduce consumption. Use natural lighting and improve the efficiency of whatever functions energy is used for. Use renewable energy where available.
- **Processes:** implement green procurement programmes, administration, budgeting and meetings.

- **Organisational culture:** create green policies, environmental management systems, formal checks and innovative incentives (e.g. green awards).

Use resources sparingly

To reduce energy consumption and resource use, consider the advice below on office utilities, supplies and equipment – as well as for mission accommodation.

Lighting

- Use natural light wherever possible.
- Replace traditional incandescent bulbs with fluorescent bulbs to reduce running costs by up to 75 % and energy consumption by 20-30 %. Replace any existing 50 W halogen lights with 20 W lights.
- Use separate light switches for different areas in your office.
- Install movement sensors or timer switches in areas such as store rooms, meeting rooms and photocopy rooms to reduce light usage. Put up eye-catching energy-saving reminder signs and stickers.

Information technology

- Switch all equipment off, if possible, when not in use (e.g. at night) and set programme equipment to hibernate when not in use during office hours.
- Make sure your computer settings are capable of the following energy-saving functions after the respective period of inactivity: 15 minutes – monitor hibernation mode (switches off); 30 minutes – system standby (hard drive switches off); 2 hours – system hibernation (entire system switches off).
- Deactivate your screensaver! Monitors should be set to hibernation, as screensavers often waste energy rather than save it.
- Minimise the number of photocopiers and printers in the office. Turn off photocopiers during periods of inactivity. The majority of electricity used by photocopiers is in the initial ‘warm up’ stage. Save your copying tasks up and do them in one batch.

Air conditioning (AC)

Climate control accounts for about 40% of an office's total energy use. Major savings in energy consumption can be made through the efficient operation of your heating, cooling and ventilation (HVAC) systems in both offices and accommodation. In urban areas, AC units generate waste heat that exacerbates the urban 'heat island' effect, so try to limit their use.

Tips on cooling buildings and using AC

- Use natural ventilation and fans where possible AND safe. Ventilate rooms early or late in the day, when the outside temperature is lower.
- Install sun protection systems around buildings to reduce the heating impact of direct sunlight.
- Set air-conditioning systems to no lower than 24° Celsius.
- If air-conditioning is used, close all windows and doors to reduce the escape of cool air.
- If the air-conditioning machine has adjustable louvres, adjust them towards the ceiling when cooling and towards the floor when heating (as cool air falls and hot air rises).
- Take advice on fitting filters to your AC to combat the threat of spreading COVID-19 and other pathogens.
- Switch off heating and cooling after office hours.

Green purchasing

Mainstream environmental criteria into all your procurement practices. Inspect potential office equipment for energy-saving and environmentally sustainable labelling. Energy-efficient products on the market today can reduce energy costs by 25-50 % or more without compromising quality or performance.

Think of longevity, reusability, refillability and recyclability when buying office equipment such as printers, scanners and photocopiers.

Water

- When boiling the kettle, only use as much water as you personally need.
- If you use a washing machine for your clothes and linen, try to wait until you can fill the machine fully.
- Make use of low-flow showerheads and taps (less than 10 litres per minute). A tap aerator reduces the use of hot water.
- Use press taps and adjust toilet cisterns to control water consumption. Use recycled water instead of drinking water for flushing toilets.

Committed management

- The UN has set up a community of practice on environmental management for all UN missions to share best practices and experience. It has created a website with advice on putting environmental sustainability into practice: www.greeningtheblue.org. Some missions have created green committees to give a local response to environmental issues. It is simple to conserve energy through switching off appliances, sufficiently insulating houses and offices, and avoiding excessive use of personal transport. However, it takes a little more understanding and commitment from management to avoid purchasing unsustainable products that are at risk of becoming obsolete or supporting unscrupulous companies that employ techniques that adversely affect the environment.

Take action, raise awareness!

- Raise awareness on environmental issues through regular meetings for all staff and through emails reminding them of environmentally beneficial measures to be adopted.
- Regularly provide comprehensive information on the ecological footprint of the mission, to raise awareness of the impact of your modes of practice.
- Publish guidelines on the use of water, electricity, paper, production of waste etc. which promote environmental sustainability. Monitor and report on the results of implementing these guidelines and publicise achievements. Adopt green guidelines during meetings and conferences as well.
- Start awareness-raising and environmentally responsible activities through a green procurement programme.
- Initiate a climate action plan by getting into contact with an elected representative at the local, state or federal level. Climate change is no longer seen only as an environmental problem – its effects on health, food production, economic development, infrastructure, and even peace and security are now commonly recognised.



Chapter 7

Personal technical considerations*

This chapter will teach you the basics of map reading, navigation and communications, and will offer you advice on how to drive a team vehicle and avoid dangers on the road.

Communications equipment

Even though familiar communications tools, such as broadband and smart phones, are usually available on most overseas deployments, you may still be faced with uncommon devices at times, ranging from the old-fashioned to the sophisticated. You may not have to resort to pigeon post, but devices such as two-way radios might be tricky for first-time users and therefore require basic technical know-how. The same applies to more advanced satellite communications (SATCOM).

This section will highlight the main types of communications equipment that you may encounter while on mission

* For full credits, references and further reading on the subjects covered in this Chapter, please refer to Credits & References Chapter 7 on p. 577

and take you through the basic steps needed to familiarise yourself with these devices.

Radio

VHF radio

Very high frequency (VHF) radio waves travel in straight lines. Just imagine for a moment that you are looking from your vehicle to your office in the distance through a pair of binoculars. The radio waves from your set are following very much the same line of sight. If you can see your office, you will be able to communicate with it. If there is a forest or mountain in the way, you cannot see your office; likewise, the radio waves travelling in the line of sight cannot get through. Obstacles such as trees, forests, houses and pylons make it difficult for VHF radio waves to follow certain paths. Obstacles either absorb the waves completely or deflect them. If you want to improve communications, find your way to high ground and send your message from a point where there are no such obstacles in the way.

Distance is naturally an important factor. As your VHF waves are broadcast outward from the antenna, they spread out like ripples of water on a pond after you drop a stone into it. The further away from you the signal travels, the weaker it becomes. Some sets are more powerful than others. You can experiment as you get to know your area and thereby

understand the distance over which you can communicate. Typically, the maximum working distance between two VHF radios is around five kilometres.

HF radio

High frequency (HF) radio is designed for longer-range communications and works by sending its signal skywards until it bounces off the electrically charged ionosphere and back to earth.

Unlike VHF sets, from which you can obtain better results through correct use, HF transmission and the clarity of your signal depend on a number of factors, most of which are usually out of your control. For example, natural phenomena such as sunspots can have a marked effect on HF radio signals.

The frequency assigned to you may work well at one time of the day and then be virtually useless at another. It may be better by day than by night, but again this is largely out of your control. Sometimes you will be told to use different frequencies at different times of the day to overcome these problems. If you have a mechanism on your HF set with which to tune your antenna, always do so. Ask how this should be done. When the antenna is not tuned, you cannot communicate, because the transmitter is disabled and reception is almost impossible.

How to use VHF and HF radio

The following is an overview of radio communications procedures that, when followed, will minimise radio time, make radio time more effective and reduce misinterpretation of radio messages.

Preparing your radio set for operation

- Ask the responsible unit in your mission for an introduction to the devices that are being used in your area of operation.
- Check the antenna and all cable connections, ensuring tight and proper connection of all components.
- Make sure that there is a power source and that it provides sufficient power. Ensure your radio set is properly connected to the power source.
- Connect the audio accessories and check the proper operation of function switches.
- Make sure you know which channels are being used for transmission.
- Turn on the radio by using the power button or turning the volume dial.
- Tune in to the correct channel and you are ready to go!

Transmitting

In general, there are five parts to transmitting a radio message that should always be followed:

1. Give the call sign of the station you are calling. This alerts the station that they are being called.
2. Say 'This is...[give your call sign].'
3. Transmit your message.
4. End your message with 'over.'
5. End the conversation with 'out.'

See the Annex for the phonetic alphabet and radio procedure words.

Some tips to improve your radio procedure are outlined below.

- Decide on a message before transmitting, ensuring it is clear and brief. Stay off the air unless you are sure you can be of assistance.
- Before you transmit, make sure no one else is speaking.
- Remember to divide your message into sensible phrases, make pauses and maintain a natural rhythm in your speech.
- Avoid excessive calling and unofficial transmissions.
- Keep a distance of about 5 cm between the microphone and your lips and hold the face of the microphone almost at a right angle to your face. Shield your microphone from background noise.

- When ready to transmit, press the transmission button and wait a second before speaking. When you have finished transmitting, wait a moment before releasing the button.
- Remember, as long as you are pressing the transmission button, no one else is able to transmit from their radio.
- Use standard pronunciation, emphasise vowels, avoid extremes of high pitch, speak in a moderately strong voice and do not shout. Speak slowly, distinctly and clearly.
- Acknowledge receipt ('copy', 'received' or 'acknowledged'). If you do not understand, ask for the message to be repeated ('say again').
- **Remember: think, press and speak – not the other way around.**

Even when you think that you speak English properly, your accent and choice of words, in combination with background noise, may make it very difficult for others to understand you. To facilitate understanding, a phonetic alphabet has been developed which helps the recipient of the message to quickly understand what you mean. When asked to spell a word, use the phonetic alphabet, which can be found in the Annex along with a list of procedure words.

Mobile phones

With mobile phone networks you can obtain broad international coverage for your mobile, including access to email through your phone. Unlike communicating over a VHF radio network (where all your colleagues within range can hear what you are saying), using a mobile phone normally gives you the luxury of a simple, one-to-one conversation.

This might sound like the perfect communications tool. However, mobile phones can present certain disadvantages:

- costs in some regions can be high, especially when using your home-country SIM or for international calls;
- coverage may be good in some areas, particularly cities, but poor or non-existent in rural areas;
- you may have to purchase a new SIM card or phone for use in some countries if your system is not compatible with local networks.

Some countries have already switched off older network versions (e.g. GSM or UMTS) in favour of LTE or 5G. Before travelling overseas, find out which mobile phone service providers operate in the country and whether your phone will work on their networks. For more information, consult <https://www.gsma.com/coverage/> and / or the web pages of local telecoms providers.

In addition, there are security-related aspects to consider.

- **Destroyed networks:** in a disaster-hit or war-torn area, the mobile phone network may have been destroyed or damaged. In this case, mobile phone communications will be unavailable or at best unreliable.
- **Jammed channels:** in times of crisis, a mobile phone system can become overloaded with too many users and it may prove impossible to make calls.
- **Political manoeuvring:** given that the local authorities can control the mobile phone system, they might just decide to turn it off.
- **Insecure conversations:** local authorities can listen in to any phone conversation. As with all forms of telecommunications you are likely to use, mobile phone conversations should always be regarded as insecure.
- **Theft:** the phones themselves are attractive items for a thief.
- **Smart phone or spying device?** Features of your smart phone, such as its camera, storage capacity, apps or location features, could get you into trouble. The mere presence of these features could cause your intentions to be misunderstood or expose you as a target for surveillance.
- **Backup your contact data:** don't rely only on your mobile. If it goes wrong or you lose it, all your contact information is gone. Always have a proper backup of

the device and keep a laminated printout of your most important phone numbers.

- **Check your installed apps:** some may be illegal and could get you into trouble at the border or in the country itself.

Satellite communications (SATCOM)

SATCOM devices are simple to use. They work like a normal mobile phone, but send signals to a satellite between 500 and 36,000 km over your head. The area on the ground where you can obtain good communications from your SATCOM is known as the ‘footprint’. Remember, just because a particular brand of SATCOM operated wonderfully on your last mission, that does not mean it will be ideal in another part of the world. The footprint may be completely different. Take the advice of your communications experts. They know what will work and what you require. The most important feature of SATCOM is a stable communications link with the ability to send and receive data at an acceptable bandwidth.

Despite the advantages of using SATCOM, you should keep the points below in mind.

- **Is it always the cheapest option?** For short-range work, VHF sets are still the most economical and useful option. If you use your mobile phone for international calls, check the rates of your mobile provider. Some-

times, it's cheaper to call via satellite than mobile or landline.

- **Channel overload:** with the increasing use of satellite phones in troubled regions, simultaneous communications can overload the capacity of satellite channels. SATCOM should not be considered a self-sufficient network, but a supplement to HF and VHF networks.
- **Makes you traceable (when you least want it!):** modern SATCOM sometimes incorporates an automatically transmitted GPS (Global Positioning System) signal. In other words, anyone monitoring your transmission will be able to establish your exact geographical position. This capability could pose a security risk for you. The parties you deal with may accuse you of revealing details of their location. In areas where such sensitivities exist, the SATCOM might be better left back at your base.

Internet and computers

These days we all use broadband and other computer networks to communicate with friends and colleagues. We know the advantages of the system, but it is extremely important to highlight the dangers below (for more information, see chapter 5 on cyber security).

- **Watch out for your information!** As with all the systems mentioned above, the internet is not secure.

- **Watch out for your computer!** Your computer is vulnerable to unscrupulous thieves who may steal it or even download large amounts of information when you are not around. Make sure you lock your portable computer away in a room or desk when you are not using it. If you use a USB stick to back up your hard disk, give it the same security attention as the hard disk. Make sure to use strong passwords to secure your computer, hard drives and USB sticks.

Organisations that may assist you in the field

There are international organisations that operate in disaster areas or complex emergencies and support other organisations with providing internet access, radio networks and services such as training. If you are working in a mission where the UN is present, check out if the Emergency Telecommunications Cluster is operating in your area (<https://etcluster.org/>).

Map reading and navigation

Map reading and navigation are essential skills while serving on emergency healthcare deployments, for three reasons:

- to enable staff to find their way around a given country and to recognise features on the ground and on a map;
- to enable staff to understand the information provided on a map so that they can picture the terrain and its possibilities and limitations;
- to assist in the quick and accurate transmission of information about the locations of people or objects.

Maps

Maps are the most important navigation aid and should be studied carefully as a preliminary to cross-country navigation. Doing so can provide the answers to many questions, such as the best route to take and areas to avoid. Maps enable the user to visualise the lie of the land, assist with sense of direction and increase confidence.

Topographic maps are detailed, graphic representations of features that appear on the earth's surface. A map's legend (or key) lists the features shown on the map and their corresponding symbols. Topographic maps usually show a geographic graticule (latitude and longitude in degrees, minutes and seconds) and a coordinate grid (eastings and

northings in metres) so that relative and absolute positions of mapped features can be determined.

How to read a topographic map

The first step in reading a topographic map is to become familiar with the specific characteristics of the map being used:

- What is the map scale?
The scale indicates the comparative size of features and distances portrayed on the map.
- Which direction is north?
The north point orientates the map to the real world.
- What symbols are used on the map?
To understand the map, the symbols need to be understood. Look at the legend.
- Which coordinate system (or datum) is used on the map? This information will be contained in the text in the map margin. Some newer maps show GPS coordinates. Remember to set your GPS to the right system, or a compatible one, and include a reference to the datum when quoting the coordinates.

Map scale

A map represents a given area on the ground. A map scale refers to the relationship (or ratio) between distance on a

map and the corresponding distance on the ground. Map scales can be shown using a scale bar.

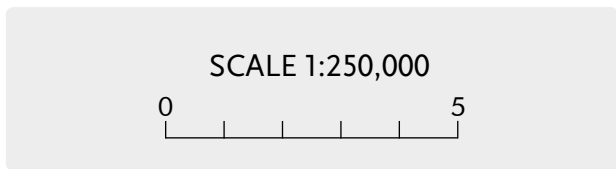

Scale bar for a 1:250,000 map

Using a 1:250,000 scale map, for example, the first number of the scale (1) represents a core unit of distance on the map while the second (250,000) represents that same distance on the ground. In this case, one centimetre on the map represents 250,000 centimetres, or 2.5 kilometres, on the ground.

The scale bar can be used to determine the distance between two points on the map. Scales are usually shown in increments of one, five or ten kilometres. Use a piece of string, a ruler or a strip of paper to measure the distance between two points on the map. Then compare that measurement to the scale bar on the map to determine what distance the measurement represents.

Direction and bearings

Maps usually include a north point diagram that shows the direction of true north, grid north and magnetic north. This

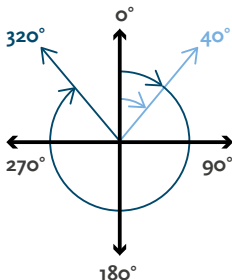
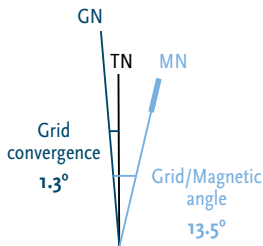

Illustration depicting bearings of 40° and 320° .



True North (TN), Grid North (GN) and Magnetic North (MN) are shown diagrammatically for the centre of the map.

MN is correct for 1997 and moves by less than 0.1° in 10 years.

Source, adapted: Australian Geological Survey Organisation.

diagram also shows the actual grid/magnetic angle for the centre of the map face.

- True north (TN) is the direction to the earth's geographic North Pole.
- Grid north (GN) is the direction of the vertical grid lines (eastings) on a topographic map. The angular difference between GN and TN is known as grid convergence.

- Magnetic north (MN) is the direction from any point on the surface of the earth towards the earth's north magnetic pole.

The angular difference between TN and MN is known as magnetic declination. As GN is used in preference to TN for map reading purposes, it is more useful to know the difference between GN and MN. This is known as the grid/magnetic angle or magnetic variation. As the position of the north magnetic pole moves slightly from year to year, the grid/magnetic angle and magnetic declination will vary by a small amount each year. In using a map for accurate navigation, magnetic variation can be important, particularly if the map is several years old.

Directions can also be expressed as bearings. A bearing is the clockwise horizontal angle, measured from north to a chosen direction. Bearings are usually shown in degrees and range from 0° (north) to 360° (also north). South is 180° , east is 90° and west is 270° .

Map symbols (the legend)

Maps use symbols to represent features on the ground. These features include roads, tracks, rivers, lakes, vegetation, fences, buildings, power lines, administrative boundaries, etc. Colour plays an important part in symbols and some international conventions apply to the use of colour. For example, blue for water features, black for culture and

green for vegetation. While most symbols are easily recognised as the features they represent, they are all explained in the map's legend.

Contour lines

Topographic maps show contour lines that join points of equal height and represent the relief in the terrain depicted. For example, if there are many contour lines close together, the terrain is steep. Contour lines that are far apart indicate land with gentle slopes.

Datums

Mapping and coordinate systems are based on a datum, which is a mathematical surface that best fits the shape of the earth. A geocentric datum is a datum that has its origin at the earth's centre of mass. The advantage of the geocentric datum is that it is directly compatible with satellite-based navigation systems.

Adopting a geocentric datum allows for a single standard of collecting, storing and using geographic data, which ensures compatibility across various geographic systems at the local, regional, national and global level.

Anyone using a map or a GPS receiver will need to know which datum is being used for the grid and the latitude and longitude coordinates.

Map coordinates

Map coordinates are usually shown in one of two ways: geographic coordinates or grid coordinates.

Geographic coordinates: latitude and longitude

You can find or express a location using the geographic coordinates of latitude (north or south – horizontal lines) and longitude (east or west – vertical lines). These are measured in degrees ($^{\circ}$), minutes ($'$) and seconds ($''$). For example, the geographic coordinates for a position could be stated as $33^{\circ}40'30''$ S, $153^{\circ}10'40''$ E. Each degree is divided into 60 minutes and each minute is divided into 60 seconds.

Latitude is the angular expression of the distance north or south from the equator (0° latitude). The South Pole is at 90° S; the North Pole at 90° N. Longitude is the angular expression of the distance east or west of the imaginary line known as the Prime Meridian (0° longitude on all maps).

Latitude and longitude coordinates are shown at each corner of a map's face. On some maps, short black lines along the edges of the map face indicate the minutes of latitude and longitude. When expressing coordinates, latitude is given first.

Grid coordinates: eastings and northings

Grid lines can also be used to find or express a location. Grid lines are the equally spaced vertical and horizontal

intersecting lines superimposed over the entire map face. Each line is numbered at the edge of the map face.

Maps are normally printed so grid north points to the top of the sheet (when the print is the normal way up). One set of grid lines runs north-south while the other set runs east-west. The position of a point on the map is described as its distance east from a north-south line and its distance north of an east-west line. For this reason, grid lines are also called:

- Eastings – these are the vertical lines running from top to bottom (north to south). They divide the map from west to east. Their values increase towards the east.
- Northings – these are the horizontal lines running from left to right (west to east). They divide the map from north to south. Their values increase towards the north.

The squares formed by intersecting eastings and northings are called grid squares. On 1:100,000 scale maps, the distance between adjacent lines represents 1,000 metres or 1 kilometre. Therefore, each grid square represents an area of 100 hectares or one square kilometre.

How to quote a grid reference for a particular point

A grid reference is used to describe a unique position on the face of the map. The degree of accuracy required will determine the method used to generate a grid reference.

All methods follow a similar approach. A four-figure grid reference is used to identify which grid square contains a map feature. A six-figure grid reference will further specify the position to an accuracy of one tenth of the grid interval. In a map's margin there is usually a section devoted to how grid references are quoted. The information needed to complete a grid reference will be found in this section of the margin.

To obtain a complete 1:100,000 scale grid reference for point A (Panoro) on the map to the left:

- Note the map name. The grid zone number, a unique identifier, can be used as an alternative. It is found in the map margin. Point A is located on the Wagin map sheet. The grid zone number is 50H (not shown in the picture).
- Read the letters identifying the relevant 100,000 metre square containing the point. In this case they are NH.
- Locate the vertical grid line to the left of the point of interest and read the two-figure easting value. Point A's easting value is 04 (dashed line).
- Estimate the tenths from the vertical grid line to the point. If using a Romer scale on the compass, place the matching scale over the point to be measured as shown in the diagram above. Using the same vertical grid line described above, count the tenths back from point A to the grid line. In this case the value is 4 (distance between the dashed line and the dotted line).

Source, adapted: Australian Geological Survey Organisation.

Example of determining a grid reference (not to scale)

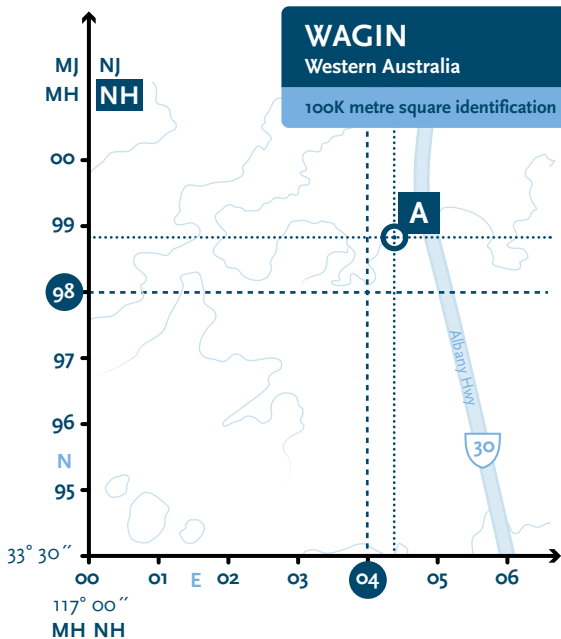

- Locate the horizontal grid line below the point of interest and read the two-figure northing value. Point A's northing value is 98 (dashed line).
- Estimate the tenths from the horizontal grid line to the point. Using the same method described above, count the tenths down from point A to the grid line. In this case the value is 8 (distance between the dashed line and the dotted line).
- Note the datum of the map from the map margin. The Wagin map is on GDA94 (not shown in the diagram). Therefore, the complete grid reference for point A is either: Wagin, NH044988 or 50H NH044988 (including the grid zone number).

Compass

The compass is a valuable aid to navigation, particularly when travelling at night or through dense vegetation where it is difficult to identify landmarks.

A compass works on the principle that the pivoting magnetised needle (or the north point of the swinging dial) always points to the north magnetic pole. As a result, a compass with graduations (degrees) marked on it can be used to measure the bearing of a chosen direction from magnetic north. Metal objects such as cars, fence posts, steel power poles and transmission lines can affect the accuracy of a compass reading. Stand clear of such objects when using

a compass – at least one metre from metal fence posts and up to 20 metres from a car.

Always make sure to hold the compass level during use. Otherwise, the magnetic needle may jam in the casing.

Using the compass to reach a destination

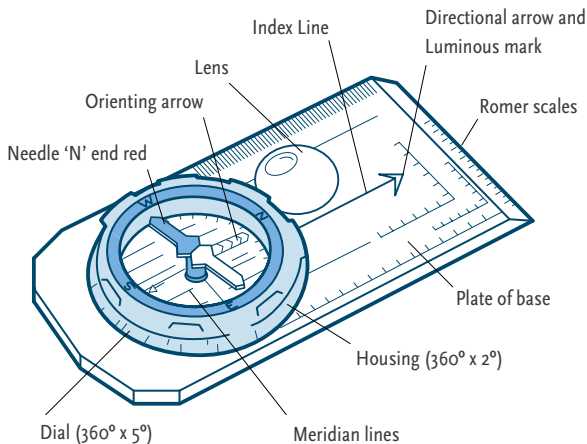

Features of a compass

There are numerous types of compasses. The pivoted needle compass with an adjustable dial is the most useful type. In addition to a north-pointing needle, such compasses often have a transparent base with a direction-of-travel arrow and orientating lines marked on the rotating dial so they can be used for measuring grid bearings on a map.

Using the compass to reach a destination

To follow compass bearings to a chosen destination, either determine magnetic bearings from visible features along the route or obtain these bearings from another source prior to travelling.

To determine magnetic bearings:

Select a visible feature along the route to be travelled and, holding the compass level, point the direction-of-travel arrow at the visible feature.

Find the bearing of the visible feature by turning the compass dial until the 'N' aligns with the marked end of the needle. Read the bearing in degrees on the dial index.

Keeping the needle aligned with the 'N', proceed in the direction indicated by the bearing at the index line. The bearing will help in keeping on track when the feature is not visible. Repeat this procedure until the destination is reached.

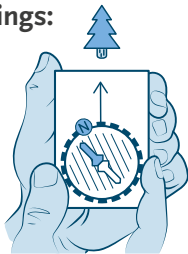

When magnetic bearings are known:

If given a bearing in degrees, the bearing is set at the index line by turning the dial. Hold the compass level with the direction-of-travel arrow pointing straight ahead.

Turn body until the red end of the needle is aligned with the N on the dial. The direction of travel is now being faced.

Pick out a visible feature in line with the bearing and walk to it. Repeat the procedure until the destination is reached.

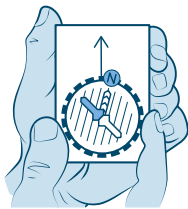

Global Positioning System (GPS)

The Global Positioning System (GPS) is a worldwide radio-navigation system, owned by the United States' government.

GPS devices may also use other systems to the US-owned one, such as Galileo, which belongs to the European Union and began operating in 2016, Beidou, which was initiated in China in 2019, and GLOSNASS, operated by Russia.

Further systems are being developed, such as India's NavIC and the Michibiki, focusing on Japan and the Asia-Oceania regions.

The American system is formed from a constellation of 31 satellites and their ground stations. GPS uses these satellites as reference points to calculate positions accurate to a matter of metres.

GPS receivers are generally hand-held devices that assist with navigation on the ground, at sea and in the air. The GPS receiver is only an aid to navigation and cannot be solely relied upon to navigate. It relies on the accuracy of the navigational data entered into the receiver.

Nowadays almost every smartphone is equipped with a built-in GPS chip similar to those found in hand-held GPS receivers. GPS-enabled phones need a third application to exploit the functionality of the GPS chip. Similar to hand-held devices, GPS applications running on smartphones

can visualise locations on digital maps, record waypoints and trackpoints, and record locations as described below.

How GPS works

The basis of GPS is triangulation from satellites. To triangulate, a GPS receiver measures distance using the travel time of radio signals. Using the signals from any three of these satellites, a two-dimensional position is fixed; using any four satellites, a three-dimensional position is fixed. The larger the number of GPS satellites visible to the receiver, the more accurate the location reading.

What GPS can do

Some general functions of most GPS receivers include:

- determining ground speed;
- plotting current position;
- storing the current position as a waypoint;
- storing other positions as waypoints;
- plotting routes travelled as tracks;
- calculating a bearing between two positions;
- determining an error left or right of the intended track;
- determining a range or distance between two positions.

GPS navigation

Navigation with a GPS receiver is similar to navigation with a compass in that a map is used with both methods and a clear understanding of the principles of map reading and navigation is essential. Similar techniques to those used with map and compass navigation are used with GPS navigation. The principles of planning the intended route, studying the map, developing navigation data sheets, etc., still exist when using GPS receivers (see below).

Using GPS with a map

GPS is based on the WGS84 datum (see explanation of datums above). By default, most receivers report geographic coordinate units of latitude and longitude in decimal degrees.

However, not all maps have a WGS84 datum. It is important to check which datum, map projection and map units are used on the map. This information is normally printed in the map margin.

For the best match between the coordinates of the map and those of your GPS receiver, configure the GPS receiver to display coordinates (geographical or grid) on the same datum as the map being used. Most GPS receivers have the ability to display either geographic or grid coordinates on a number of national and regional datums. It is important to know how to set the correct datum in the receiver. Please

consult the GPS receiver's user guide for details. If the datum needed is not offered in the receiver, consult the relevant unit in your mission (e.g. GIS technician) for assistance.

It is recommended practice to check the GPS receiver against well-defined map features every time it is used. Visit a feature such as a road intersection, determine its position by GPS and compare this with coordinates calculated from a map. The larger the scale of this map, the better.

GPS performance and limitations

GPS receivers need to have a clear, uninterrupted view of the sky to enable communication with the satellite constellation (network). Some conditions that may interfere with the GPS signal include:

- cloud cover;
- vegetation;
- operating inside a building, or next to tall buildings;
- operating inside a motor vehicle without an external GPS antenna;
- operating in urban canyons, gorges, caves, mines and other underground or low ground areas;
- GPS receivers can also be affected by electrical storms.

GPS receivers are equipped with a built-in compass and altimeter sensor. These two instruments need to be cali-

brated prior to setting off on a new field mission. This operation normally involves rotating the GPS around both its horizontal and vertical axes. To calibrate the compass, find the GPS settings and follow the instructions given by the manual.

Most commercial GPS receivers are accurate to approximately 50 metres horizontally and 70 metres vertically. In ideal conditions, accuracies of about 10 metres can be reached. As GPS receivers are powered by batteries, it is important that you know the duration and condition of those batteries, particularly before heading into rural or remote areas. You should of course carry spare batteries, but as a backup to the GPS receiver, make sure that you have a magnetic compass and map with you at all times.

Types of data that can be collected using GPS

There are two basic types of data that can be collected and stored in the memory of the GPS unit. These are waypoints (or points) and track logs (or tracks).

Waypoints (WPs) are a record of a specific point on the ground that has been visited. Normally a data set of latitude, longitude and elevation documents a WP. Track logs are a record of a series of points that are collected automatically every few seconds by the GPS to record the path travelled by the GPS receiver during a field journey.

How to use GPS to collect data

Below are some suggestions for using GPS to collect data in various situations on missions.

- Road assessments: WPs can be recorded at damaged sections of roads and at villages and settlements. Track logs can record the route taken.
- Village assessments: WPs can be recorded at road intersections and at prominent buildings (e.g. police stations, schools or hospitals).
- Flood and damage surveys: GPS can be used to capture the extent of various types of damage, for example a flood or area of collapsed buildings.
- Photographs: the locations of photographs taken can be recorded, for example when recording damage to specific structures or facilities.
- Aerial assessments: GPS units are flight safe because they do not transmit; they only receive signals.

Remember that the GPS unit only records the WP numbers: a record of what each of these points represents must be made by means of attributes. The attributes can be recorded in the device itself, in a notebook or on a form designed for this purpose.

Planning

Prior to travelling, divide your chosen route into legs. Each leg should end at an easily recognisable landmark. Then produce a navigation data sheet for the entire route, which gives significant information for each leg of the route.

Orientating a map

Orientate the map before reading it. To do this, hold the map horizontally and rotate it until its direction and features correspond to what is seen on the ground. If you are unable to identify the surrounding features, use the compass to orientate the map as explained below.

- Lay the map flat and place your compass so that the edge of the base lies along any grid north line and the direction-of-travel arrow is also pointing to grid north.
- Rotate the map and compass until the north point of the compass needle is east or west of the index line by the amount of the grid/magnetic angle shown in the map's margin.

Once the map is orientated, prominent features in the landscape can be identified.

Finding your current position

Once you have set your GPS receiver to a datum corresponding to the datum on the map, you can use your GPS to determine the coordinates of your current position. Alternatively, once you have identified surrounding features on the ground and on the map, use the following procedure to find your current position.

- Choose two visible features and find these on the map. Now point the direction-of-travel arrow towards one feature and rotate the compass dial until the red end of the needle points to the 'N' on the dial.
- Place the compass on the map with the edge of the base touching the feature and pivot it until the orientating arrow or lines align with the grid north lines. Draw a line from the feature along the side of the base across the map.
- Repeat this process with the second feature. The present location is where the two lines meet.

Setting a course

Once you have orientated your map and identified your current position, you can set your course. Do this by sighting or by laying a straight line across the map (using the

Alternative use of the map and compass

Before starting, place the compass on the map so that the edge of the base connects the present position (in this case, No. 5 Bore) to the destination (No. 11 Bore), and the direction-of-travel arrow is also pointing that way.

Turn the compass dial until the orientating lines are parallel with the grid north lines on the map and the orientating arrow is also pointing to grid north.

Put the map aside. Hold the compass steady and level with the direction-of-travel arrow pointing straight ahead. Rotate until the red end of the needle is directly over the orientating arrow, pointing to 'N' on the dial. The direction-of-travel arrow now points to the destination (No. 11 Bore).

Look up, align the direction-of-travel arrow with a feature and walk to it. Repeat this procedure until the destination is reached.

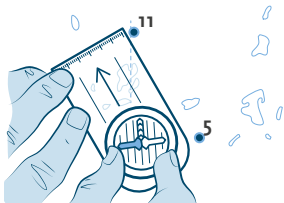

edge of the map card or a piece of string). It is also good practice to identify a distant visible feature that is on the line, such as a rocky outcrop, and proceed to that point. Then identify another feature on the line, and so on, until the destination is reached.

When features are sparse, you can use a GPS receiver. First, determine the coordinates of the destination point from the map and enter them into the receiver. Then walk in the approximate direction of the destination, letting the receiver indicate the right direction.

Maintaining direction using a compass

When moving through dense vegetation, it is important that you make continuous checks with the compass. The best method of maintaining a given magnetic bearing is to select a prominent object (such as a tree) that lies on the bearing and move to it. Then select another object on the bearing and move to that. Continue with this method until the destination is reached. If it is impossible to find a prominent object on the bearing, then send another person forward about 100 metres, correct them onto the bearing and then proceed to them. Again, repeat this procedure until the destination is reached.

Once a course commences, checking must be continuous. Check all features such as hills and rivers when you reach them and identify them on the map. Note the direction of

flow of all streams and rivers and check that with the map. Identify tracks but always regard them with suspicion. It is easy to place too much confidence in a track which may not be the one marked on the map.

Distance travelled

It is very important, particularly when moving through vegetation, to know the distance that you have covered. There are two basic methods for achieving this: pacing and time.

Pacing

- This is generally accepted as being the more reliable method.
- Distances can be counted by the number of paces you take.
- These paces can be translated into kilometres, depending on the type of terrain and the average length of pace.
- Experience has shown that over long distances it is better to count right foot paces only, rather than each pace.
- To make recording easier, use small pebbles or seeds and transfer these from one pocket to another every 100 paces.
- For a 76 cm (30 inch) pace, 657 right foot paces will equal one kilometre.

- To calculate your personal pace length, measure out a 100 metre flat distance and count how many right foot paces you take to complete that distance.

Time

- Distance can also be calculated by the time spent walking in relation to the speed of walking, in kilometres per hour.
- For the average person walking over fairly flat country, a 76 cm (30 inch) pace will result in a speed of about 5 kilometres per hour.
- Naismith's rule, devised by a Scottish mountaineer in 1892, allows for 1 hour per 5 km (3.1 miles) forward plus 1 hour for every 600m (2,000ft) of ascent.

Transport

Four-wheel drive vehicles

When you are deployed, you might be required to drive around in a four-wheel drive (4WD) vehicle. Although you may already be used to driving one, it is important to know what makes a 4WD unique. In case you are out of practice or you do not have much experience in driving a 4WD vehicle, arrange some four-wheel driving lessons before leaving on a mission.

Four-wheel drive means that four road wheels provide power for the vehicle; 4WD is often selectable, but in some cases all wheels provide drive all the time (constant 4WD, e.g. Range Rover). In most cars, only two wheels provide power and the others 'freewheel'. In the past, the driving wheels were usually the rear wheels, but now front-wheel drive is more common. Most 4WD vehicles still use rear-wheel drive in normal situations, with front-wheel drive engaging when the driver selects 4WD. To reduce wear, noise and fuel consumption, 4WDs are often fitted with freewheeling hubs on the front wheels.

Why do 4WD vehicles need special handling?

There are a number of important differences between a normal car and a 4WD vehicle. The 4WD is usually about

the same weight as an ordinary vehicle, but has a higher centre of gravity, so it is less stable. It may have a shorter wheelbase and a larger turning circle. The tyre size and tread pattern may be more suitable for off-road conditions than for sealed roads. The two driving axles and the transfer case allow for the use of high or low ratio and four-wheel drive. All these differences go to make up a vehicle that requires special handling skills. Successful four-wheel driving takes practice and skill, and comes with experience.

Principles of four-wheel driving

The principles below apply to driving off-road or on a poor road in a 4WD vehicle.

- **Assess and plan.** Get out and physically check the obstacle before committing yourself to crossing it.
- **The first attempt** at crossing an obstacle is usually the best, especially in muddy or slippery conditions.
- **The right gear.** The right timing. Select a suitable gear before attempting the obstacle. Changing gear in the middle of an obstacle may cause wheel spin and loss of traction.
- **When in doubt, trust throttle control.** In difficult conditions, allow the vehicle to inch along, finding its own way purely with throttle control (i.e. engine revs at idle speed or just above idle speed, no clutch or brakes).

- **Do not over-rev the engine.** Use only the amount of engine torque needed for the job.
- **Slow down.** To overcome wheel spin, take your foot off the accelerator.
- **When braking, avoid locking up the wheels.** If wheels do skid, ease off the brakes until traction is regained.
- **'After you!'** When two or more vehicles are travelling in convoy, cross an obstacle one at a time.

Vehicle kit & checklist

The following is a list of items that you need to take with you in your vehicle and keep an eye on at all times:

- tyres (in good condition, sufficient air pressure, including the spare!);
- oil, coolant, fuel (check levels regularly, never allow fuel tank to be under half full);
- tools (all in place, including wheel jack and wrench for wheel nuts);
- spare fan belt, extra fuel in cans (if needed), spare tyre (inflated);
- individual protective gear (if required), e.g. helmet, flak jacket;
- drinking water, spare/emergency food;
- first aid kit;
- sleeping bag/blankets (e.g. in cold climates or for first aid);
- flashlight and spare batteries;
- map, compass, GPS;
- vehicle logo/flag (if your organisation has one);
- lights (functioning headlights, tail lights, brake lights, indicators and lights to illuminate logo/flag);
- documents required by organisations or local authorities, e.g. vehicle log, registration and insurance papers.

Unmanned aerial vehicles (UAVs)

As the development and use of new technologies is expanding worldwide, the importance of unmanned aerial vehicles (UAVs) has also increased significantly in recent years. While some argue that UAVs will become a common tool in future crisis management operations, the debate around UAVs has historically tended to focus on moral issues and the use of drones for military strikes. However, today's use of UAVs is much broader and includes innovative, economic and professional ways of investigating what is happening on the ground. This can be valuable in diverse and dangerous contexts such as natural disasters, armed conflicts or fragile states.

The legal basis for the civilian use of UAVs is controversial: legal frameworks on the humanitarian use of UAVs are often absent, which is why in practice, ad hoc solutions with local authorities are often arranged. These arrangements, however, are short-term and lack transparency, clear policies, standards or guidelines. Information pertaining to the timing of flights, purpose, and type of data being collected should always be communicated to the public, though this is rarely the case.

Further contentious issues around the use of UAVs are the collection, selection, use and transfer of data, assignment and responsibility of tasks, logistical problems and the ambivalent impact the use of UAVs may have on ongoing processes on the ground.

As the pressure to adopt new technologies is expected to increase for both military and civilian actors, clear policies, legal frameworks and strict standards are urgently needed. Organisations such as the Humanitarian UAV Network are working to improve the legitimacy of UAVs by creating a platform, compiling good practice and developing international guidelines for their safe and transparent civilian use.



Chapter 8

Handover and departure*

Final in-country steps

Handover

Mission planning must, from the outset, include a transition or exit strategy – with the understanding that the strategy will require constant adjustment. This may include planning, preparing and coordinating the political groundwork for a successor mission, or a systematic handover of responsibilities to local authorities and other partners.

Whichever the case, transparency, clarity, attention to detail and good communication with partners are essential to the handover process. A good handover makes sure that your work and achievements do not go to waste. It warns your successors of likely pitfalls and risks and provides them with all the knowledge and contacts they need. For a successful handover, put yourself in the position of your successor: what would you want or need to know?

* For full credits, references and further reading on the subjects covered in this Chapter, please refer to Credits & References Chapter 8 on p. 578

Think about (or find out) the specific experience and knowledge of the person you are handing over to and tailor your handover accordingly. Use clear systems and records to store information and make sure you put into writing important knowledge that exists only in your head. Handover notes should be finalised before you leave. A copy should be provided to your successor as well as your supervisor. Ideally, there should be a period of overlap with your successor.

A handover can include:

- a written handover file or handover notes;
- a handover meeting between outgoing and incoming staff;
- individual meetings;
- meetings with relevant contacts to introduce your successor;
- a social event for outgoing and incoming staff.

Closing a programme

A project or programme should be formally closed to ensure that:

- operational procedures are in place;
- the handover to operational staff has been completed;
- documentation and reference materials are in place;
- any further actions and recommendations are documented and disseminated;
- the results are disseminated to relevant people;
- there are no loose ends.

The closure of a programme, for whatever reason, should be carefully prepared. Staff are likely to be disappointed about losing their jobs. Local leaders, contractors, partners and beneficiaries may protest against losing the assistance provided through the programme. Care is needed to ensure that the closure is well managed.

Ending staff contracts

The process of terminating contracts should be carefully planned and sensitively managed. Ties of loyalty may have been built up over time and some staff may feel that their loyalty is not being rewarded. Contracts should have been drawn up initially with the possibility of short notice being given in times of crisis, so that staff know what to expect.

Local employment laws and customs should be followed scrupulously. A good local lawyer is likely to be needed: their fees may be much less than the cost of legal action that might otherwise result.

Above all, the process should be fair and perceived to be fair. Managers should ensure that there is clear communication about the process and consultation where possible.

Ending supplier contracts

Contracts with local companies, owners of buildings and others may need to be ended as well. In an insecure environment where a crisis is likely to result in termination of contracts at short notice, clauses should be incorporated into contracts at the outset of the programme to deal with such situations. Transparency, fairness and attention to detail are important. Once again, a local lawyer may be useful.

Any outstanding claims or legal cases should be resolved before the departure of the manager. To leave without such resolution could increase risks to staff and former staff as well as to other organisations; and it would damage the reputation of your organisation.

Disposing of property

Early decisions should be made on how to dispose of the organisation's property. Some property may be sold or given

to local organisations. Some may be redistributed or moved to a central storage location by the organisation for use in other programmes. These decisions will depend on the requirements of donors, on the rules of the organisation and on the judgment of the manager concerned.

Evaluation and inspection

Evaluations or inspections of programmes may be required by the organisation before the programme closes. These should be taken into account when planning the closure. In particular, will key staff be available for interviews if required?

All key documents and reports should be archived properly. This enables accountability should any future investigation be made. It can also protect the organisation against any false claims.

Final report

The main purpose of reports is to inform readers about any progress made as well as challenges encountered in your field work during the reporting period. The final report (also referred to as an end-of-assignment report) reflects your contribution towards achieving your mandate and tasks. It should identify lessons learned, come to conclusions regarding successes and pitfalls, and facilitate future decision-making.

The purpose of a final report is to provide an assessment of the implementation of the mission's mandate, particularly with regard to the specific area of your responsibility. It should offer recommendations for improving the effectiveness and efficiency in implementing the mission's mandate, with the aim of informing policies, procedures and practices. The report should also focus on lessons and good practices, and highlight replicable factors that contributed to success or failure.

Mission debrief

A mission debrief will take place with specified staff to enable personnel to discuss their involvement during the deployment and to draw out any lessons for the organisation to enrich institutional memory.

The following points may be covered:

- pre-departure;
- arrival in-country and orientation;
- mission activities;
- relations with other organisations and entities;
- organisational and administrative issues;
- equipment;
- other issues and comments.

Returning home

Medical checkup

You should seek medical consultation and treatment promptly if you have signs of any illness or injury following deployment. Of particular concern are persistent fever, coughs or abdominal upsets with diarrhoea, as these might result from a disease contracted during deployment.

Many tropical illnesses do not exhibit symptoms for months after being contracted or may be confused with the effects of exhaustion and stress resulting from the deployment. In order to rule out tropical illnesses, it is advisable to consult a doctor with experience in tropical medicine.

If you had any sexual contact during your deployment or if you lived in an area strongly affected by HIV/AIDS, you should get tested for HIV/AIDS and venereal diseases. HIV tests may not be positive until about three weeks after exposure to the virus.

If signs of stress persist after returning home from deployment, you should consult a professional mental healthcare provider.

Medication

You should continue to take medication (especially anti-malarial drugs) according to the regime established by the manufacturer of the medication even after departing from the deployment location. This information may be found in the packaging of the medication or can be discussed with your responsible doctor.

Reintegration: work and family

Reintegration with family and former colleagues can turn out to be difficult. After coming home from your deployment you may want to talk about your experiences, while others do not want to listen or are unable to grasp the messages because they have not had similar experiences. Equally, it may prove difficult if you do not want to talk about your experience when others keep asking. Understanding what sorts of reactions to expect from yourself and your family and friends when you return home is important in making your reintegration less stressful.

Prepare yourself for a range of emotional reactions, such as excitement, disorganisation, disorientation, resentment and frustration. Things may not be as smooth as you had imagined. Some things may have changed while you were away and you yourself may have changed in your outlook and priorities of life. You may also miss the excitement of the mission for a while and feel displaced.

Reverse culture shock

A reverse culture shock is classically experienced as a period of depression or apathy after the initial excitement of returning home. This stage can be very challenging, as feelings of isolation and confusion are common. Reverse culture shock can last for several months and is often not well understood. The lack of tolerance and patience displayed at home can make you feel displaced or misunderstood, and could reinforce feelings of depression that you may be experiencing. Reverse culture shock is likely to have an impact on friendship and family relations. This particularly applies to partnerships – where difficulties in re-establishing confidence, trust and intimacy may occur – and to children who, depending on their ages, may react in unexpected ways. Open communication by all parties is key in handling those issues.

Factors contributing to reverse culture shock

There are many reasons why reverse culture shock occurs, but the major contributing factors are outlined below.

- The reality of home differs from the home you remember. Over the course of your assignment, you may have idealised or romanticised home. It is easy to forget or minimise the issues that were once sources of stress in your everyday life.

- Things change. Change may have occurred to everyone back home and to everything. Learning about these changes and adjusting to them can be very stressful.
- You will also have changed. You may have adopted different values and find it hard that people do not seem interested in the matters which concern you (such as caring about world issues).
- People may not react to you or your experiences in the way you expected. Many returnees find it difficult to connect with people and society in the ways they used to or may be frustrated by people's limited attention span for their experiences during deployment.

As with every aspect of the reverse culture shock, the way in which you overcome the challenges you face will be highly personalised. However, simply by being aware that reverse culture shock exists can already ease the process to some extent.

Strategies for dealing with reverse culture shock

Some possible strategies for dealing with reverse culture shock are outlined below.

- Start mentally preparing yourself for the adjustment process before ending your assignment. Ongoing reflection is useful in terms of clarifying your thoughts and feelings.

- Take your time when coming home, both physically and mentally. Go easy on yourself and avoid setting deadlines for major life decisions.
- Cultivate good listening practices. One of the best ways to ensure that you have an audience for your stories is to show that you care about their stories. Being a good listener will reinforce mutually respectful and beneficial relationships.
- Learn about what has changed with regard to family members, friends, politics, the job market and so on. Try to adapt to new routines and situations.
- Renegotiate your roles and responsibilities at work and at home. The workload can be shared in new ways.
- Seek and engage in support networks. Many people find that the biggest challenge of returning home is finding people who are like-minded or with whom they can share their experiences. In order to overcome this, you may want to maintain contact with colleagues or find other outlets that attract people of a similar mindset.
- Find ways to incorporate your new interests and cross-cultural skills into your life at home.

Post-deployment stress

Be aware that it is possible that you will experience post-deployment stress after returning home. You may suffer

repercussions or delayed after-effects, particularly if you coped successfully during the actual crisis. Typical reactions may be similar to those encountered during the mission.

Symptoms of post-deployment stress

- sleep disturbance
- restlessness and anxiety
- re-experiencing events
- feelings of emotional emptiness
- irritability
- self-reproach and feelings of guilt
- aggressiveness and hatred
- problems concentrating
- physical complaints

Strategies for dealing with post-deployment stress

- Be patient and make time for recovery. It takes time to adjust to your new environment both physically and mentally. Following stressful experiences, it is natural to require more than your usual rest and sleep. This may be difficult because you have been away from family and loved ones who will also need attention. Recognise that you may need more time alone than usual to process your experiences and impressions, as well as to adapt to daily life at home.

- Try to look after your physical well-being. As well as getting adequate rest, it is helpful to exercise. Avoid the excessive use of alcohol or drugs to cope with your feelings and emotions, as it tends to make things worse.
- Communicate your experiences. Talk about your experiences, but keep in mind that others may not share the same interest in your mission experience or may lose interest sooner than you expect. Expressing your feelings and experiences through other channels such as the arts or cultural activities (e.g. writing, painting, dancing) may also be helpful.
- Seek help if necessary. Although it is natural to experience post-deployment stress, you should seek help in the recovery process if necessary. If symptoms last longer than 30 days or become more intense, it is advisable to seek assistance from a trained professional. It is not uncommon to develop depression after the mission, but it can be effectively treated.

Phonetic Alphabet

Letter pronunciation

A	ALFA	N	NOVEMBER
B	BRAVO	O	OSCAR
C	CHARLIE	P	PAPA
D	DELTA	Q	QUEBEC
E	ECHO	R	ROMEO
F	FOXTROT	S	SIERRA
G	GOLF	T	TANGO
H	HOTEL	U	UNIFORM
I	INDIA	V	VICTOR
J	JULIET	W	WHISKY
K	KILO	X	XRAY
L	LIMA	Y	YANKEE
M	MIKE	Z	ZULU

Numbering Digit pronunciation

0	ZERO	5	FIFE
1	WUN	6	SIX
2	TOO	7	SEVEN
3	TREE	8	ATE
4	FO-WER	9	NINER

For better understanding, numbers are transmitted digit by digit except that exact multiples of hundreds and thousands are spoken as such. Some examples of pronunciation of numbers may be seen below:

12	WUN TOO
44	FO-WER FO-WER
90	NINER ZERO
138	WUN TREE ATE
500	FIFE HUNDRED
7,000	SEVEN THOUSAND
16,000	WUN SIX THOUSAND
1478	WUN FO-WER SEVEN ATE
19A	WUN NINER ALFA

Signal quality is reported as strength / readability as follows:

<i>Signal Strength</i>	
LOUD	Your signal is strong
GOOD	Your signal is good
WEAK	I can hear you but with difficulty
VERY WEAK	I can hear you but with great difficulty
<i>Readability</i>	
CLEAR	Excellent quality
READABLE	Good quality, no difficulty in reading you
DISTORTED	I have problems reading you
WITH INTERFERENCE	I have problems reading you due to interference
NOT READABLE	I can hear that you are transmitting but cannot read you at all

Radio procedure words

<i>Pro word</i>	<i>meaning</i>
ACKNOWLEDGE	Confirm that you have received my message.
AFFIRM	Yes/correct.
NEGATIVE	No/incorrect.
ALL AFTER	Everything that you / I transmitted after.
ALL BEFORE	Everything that you / I transmitted before.
BREAK-BREAK-BREAK	All stations will immediately cease transmission on hearing this pro-word. The station BREAKING has an urgent life-saving message. Only to be used in extreme emergency.
CORRECT	You are correct. Your last transmission was...
CORRECTION	The correct version is...
WRONG	Incorrect, the correct version is...

DISREGARD THIS TRANSMISSION	This transmission is an error, disregard it.
DO NOT ANSWER – OUT	Station(s) called are not to answer this call, acknowledge this message, or transmit in connection with this transmission.
FIGURES	Numbers follow in message
MESSAGE	I have an informal message for you.
MESSAGE FOLLOWS	I have a formal message that should be recorded.
OVER	I have finished my turn, a response is expected, go ahead, transmit.
OUT	I have finished my transmission, no reply is expected. (OVER and OUT are never used together.)
OUT TO YOU	I have nothing more for you, do not reply, I shall call another station on the net.
READ BACK	Read back the following message to me exactly as received.

I READ BACK	The following is my reply to your request to read back.
RELAY TO	Transmitting the following message to all addresses or to the address immediately following.
RELAY THROUGH	Send this message by way of call sign...
ROGER	I have received your last transmission satisfactorily.
ROGER SO FAR?	Have you received this part of my message satisfactorily?
SAY AGAIN	Repeat all of your last transmission.
SAY AGAIN ALL AFTER / BEFORE	Repeat portion of message indicated.
I SAY AGAIN	I am repeating my transmission or portion as indicated.
SEND	Go ahead with your transmission.
SEND YOUR MESSAGE	Go ahead, I am ready to copy.

SILENCE- SILENCE- SILENCE	Cease all transmission immediately. Silence will be maintained until lifted by network control operator.
SILENCE LIFTED	Silence is lifted, net is free for traffic.
SPEAK SLOWER / FASTER	Adjust the speed of your transmission.
I SPELL	I shall spell the next word phonetically.
THROUGH ME	I am in contact with the station you are calling. I can act as a relay station.
MESSAGE PASSED TO...	Your message has been passed to...
UNKNOWN STATION	The identity of the station calling or with whom I am attempting to establish communication is unknown.
VERIFY	Verify entire message (or portion indicated) with the originator and send correct version.

I VERIFY	That which follows has been verified at your request and is repeated – to be used only as a reply to VERIFY.
WAIT-WAIT-WAIT	I must pause for a few seconds.
WAIT OUT	I must pause longer than a few seconds and will call you again when ready.
WILCO	I have received and understood your message and will comply.
WORDS AFTER / BEFORE	The word of the message to which I refer is that which follows...
WORDS TWICE	Communication is difficult, transmit each phrase twice.

List of abbreviations

4WD	Four-wheel drive vehicle
AAR	After-action review
Africa CDC	Africa Centres for Disease Control and Prevention
AFRO	WHO Regional Office for Africa
AI	Artificial intelligence
ALS	Advanced life-support
AMRO	WHO Regional Office for the Americas (also known as PAHO)
AMU	Arab Maghreb Union
APEC	Asia-Pacific Economic Cooperation
APM	Anti-personnel mine
ASEAN	Association of Southeast Asian Nations
AU	African Union
AVM	Anti-vehicle mine
BLS	Basic life-support
BSL	Biosafety level
BTWC	Biological Weapons Convention
CBO	Community-based organisation
CCHF	Crimean-Congo haemorrhagic fever
CDC	US Centers for Disease Control and Prevention
CDEMA	Caribbean Disaster Emergency Management Agency

CEDAW	Convention on the Elimination of All Forms of Discrimination against Women
CEN-SAD	Community of Sahel-Saharan states
CEPI	Coalition for Epidemic Preparedness Innovations
CFR	Charter of Fundamental Rights (European Union)
CHE	Complex humanitarian emergency
CMAM	Community-based management of acute malnutrition
COMESA	Common market for Eastern and Southern Africa
COMISCA	Council of Ministers of Health of Central America
CRC	Convention on the Rights of the Child
CSDP	Common Security and Defence Policy (European Union)
CWC	Chemical Weapons Convention
DALY	Disability-adjusted life year
DG	Directorate-General
DG DEVCO	Directorate-General for International Cooperation and Development (European Commission)
DG ECHO	Directorate-General for European Civil Protection and Humanitarian Aid Operations (European Commission)

DG RTD	Directorate-General for Research and Innovation (European Commission)
DG SANTE	Directorate-General for Health and Food Safety (European Commission)
DHIS2	District Health Information Software 2
DU	Dual use
DURC	Dual use research of concern
EAC	East African community
EC	European Commission
ECCAS	Economic Community of Central African States
ECDC	European Centre for Disease Control and Outbreak
ECOWAS	Economic Community of West African States
EEAS	European External Action Service
EMA	European Medicines Agency
EMRO	WHO Regional Office for the Eastern Mediterranean
EMT	Emergency Medical Team (United Nations)
EPHOS	Essential public health operations
ERC	Emergency Relief Coordinator (United Nations)
ERCC	Emergency Response Coordination Centre of DG ECHO (European Commission)
ERU	Emergency Response Unit (Red Cross / Red Crescent)
ERW	Explosive remnants of war

EU	European Union
EUCPM	EU Civil Protection Mechanism
EURO	WHO Regional Office for Europe
EVD	Ebola virus disease
EWARS	WHO's Early Warning, Alert and Response System
FAO	Food and Agriculture Organization (United Nations)
FFP	Filtering face-piece (mask / respirator)
FPI	Service for Foreign Policy Instruments (European Commission)
GAVI	The Vaccine Alliance
GBD	Global burden of disease
GDP	Good distribution practice
GFATM	The Global Fund to Fight AIDS, Tuberculosis and Malaria
GHC	Global Health Cluster
GIS	Geographic information system
GMP	Good manufacturing practice
GOARN	Global Outbreak Alert and Response Network
GPS	Global Positioning System
GSP	Good storage practice
GWC	Global WASH Cluster
HCID	High consequence infectious disease
HEAT	Hostile environment awareness training

HF	High frequency
IANPHI	International Association of Public Health Institutes
IASC	Inter-Agency Standing Committee
ICESCR	International Covenant on Economic, Social and Cultural Rights
ICH	International Conference on Harmonisation
ICRC	International Committee of the Red Cross
ICT	Information and communication technology
IDA	International Development Association
IDP	Internally displaced person
IED	Improvised explosive device
IFRC	International Federation of Red Cross and Red Crescent Societies
IGAD	Intergovernmental Authority on Development
IHL	International humanitarian law
IHR	International health regulations
IMC	International Medical Corps
IOM	International Organization for Migration
IPC	Infection prevention and control
JEE	Joint external evaluation
JRC	Joint Research Centre (European Commission)
LF	Lassa fever
LMICs	Low- and middle-income countries
M&E	Monitoring and evaluation

MAM	Moderate acute malnutrition
MCDA	Military and civil defence assets
MdM	Médecins du Monde
MEDEVAC	Medical evacuation
MMR	Measles, mumps & rubella
MSF	Médecins Sans Frontières (Doctors Without Borders)
MUAC	Mid-upper arm circumference
MVD	Marburg virus disease
NCD	Non-communicable disease
NDMO	National disaster management office
NGO	Non-governmental organisation
NPHI	National public health institute
NS	National Red Cross and Red Crescent Society
NSAG	Non-state armed group
OCHA	United Nations Office for the Coordination of Humanitarian Affairs
OECD	Organisation for Economic Co-operation and Development
OHCHR	Office of the United Nations High Commissioner for Human Rights
OPCW	Organisation for the Prohibition of Chemical Weapons
ORS	Oral rehydration solution

OSCE	Organization for Security and Cooperation in Europe
PAHO	Pan American Health Organization
PEF	Pandemic Emergency Financing Facility (World Bank)
PFA	Psychological first aid
PHE	Public Health England
PHEIC	Public health emergencies of international concern
PHT	European public health team
PIF	Pacific Islands Forum
PLW	Pregnant and lactating women
PoA	Power of attorney
PoC	Point of contact
PoW	Prisoner of war
PPE	Personal protective equipment
PTSD	Post-traumatic stress disorder
QMS	Quality management system
RC	Resident Coordinator (United Nations)
RCM	Refugee coordination model (UNHCR)
RDM	Rapid deployment mechanism (ICRC)
RKI	Robert Koch Institute
RL	Reference laboratory
RRM	Rapid response mechanism (IFRC)
RRML	Rapid response mobile laboratory

RRP	Refugee response plan
RUTF	Ready-to-use therapeutic food
SAARC	South Asian Association for Regional Cooperation
SADC	Southern African Development Community
SAM	Severe acute malnutrition
SATCOM	Satellite communications
SCO	Shanghai Cooperation Organisation
SCR	Security Council Resolution (United Nations)
SDGs	Sustainable Development Goals (United Nations)
SEA	Sexual exploitation and abuse
SEARO	WHO Regional Office for South-east Asia
SG	Secretary-General
SICA	Central American Integration System
SOP	Standard operating procedure
SORMAS	Surveillance Outbreak Response Management and Analysis System
STAKOB	Competence and treatment centres for high consequence infectious diseases, RKI
STI	Sexually transmitted infection
TFC	Therapeutic feeding centre
TFEU	Treaty on the Functioning of the European Union
ToR	Terms of reference

UAV	Unmanned aerial vehicle
UDHR	Universal Declaration of Human Rights
UN	United Nations
UNCT	United Nations Country Team
UNDAC	United Nations Disaster Assessment and Coordination
UNDP	United Nations Development Programme
UNDSS	United Nations Department of Safety and Security
UNEP	United Nations Environment Programme
UNHCR	United Nations High Commissioner for Refugees
UNICEF	United Nations Children's Fund
UNODA	United Nations Office for Disarmament Affairs
UNOMS	United Nations Ombudsman and Mediation Services
UNSGM	United Nations Secretary-General's Mechanism for the Investigation of Alleged Use of Chemical and Biological Weapons
UTC	Coordinated universal time
UXO	Unexploded ordnance
VBM	Valuable biological materials
VHF	Very high frequency
WAHO	West African Health Organization
WASH	Water, sanitation and hygiene

WFP	World Food Programme (United Nations)
WHO	World Health Organization (United Nations)
WMO	World Meteorological Organization
WP	Waypoint
WPRO	WHO Regional Office for the Western Pacific
ZIG	Centre for International Health Protection, Robert Koch Institute

Credits & References

Authors for each section are bylined below. Any sections that are not bylined have been adapted from an earlier version of *In Control* or have been contributed by the editors.

Chapter 1

Defining international health protection

Authored by:

Dr Iris Hunger, Robert Koch Institute, Berlin, Germany

Prof. Dr Johanna Hanefeld, Robert Koch Institute, Berlin, Germany

Reference:

Public Health England, UK Government, Definition of HCID.

<https://www.gov.uk/guidance/high-consequence-infectious-diseases-hcid#definition-of-hcid>

[accessed 1 October 2020]

Figure 1.1 Adapted with permission, from the document *Clustering of Essential Public Health Operations (EPHOs) - to deliver public health services*

<https://www.euro.who.int/en/health-topics/Health-systems/public-health-services/policy/the-10-essential-public-health-operations>

[accessed on 20.11.2020].

The United Nations

Emergency Medical Teams

Authored by:

Flavio Salio, World Health Organization, Geneva, Switzerland

Marie Chantal Claravall, World Health Organization, Geneva, Switzerland

References:

World Health Organization, *Classification and minimum standards for Foreign Medical Teams in sudden onset disasters*, Geneva, 2013.

<https://www.who.int/csr/resources/publications/ebola/foreign-medical-teams/en/>

[accessed 8 November 2020]

World Health Organization, Emergency Medical Team Coordination Cell, *Coordination Handbook, Draft Version 10*, Geneva, 2016.

http://origin.searo.who.int/about/administration_structure/hse/ent_coord_handbook.pdf

[accessed 1 October 2020]

World Health Organization, Emergency Medical Teams.

<https://extranet.who.int/emt/>

[accessed 1 October 2020]

Global Outbreak Alert and Response Network**Authored by:**

Dr Sandra Beermann, Robert Koch Institute, Berlin, Germany

Dr Evgeniya Boklage, Robert Koch Institute, Berlin, Germany

References:

Mackenzie, J. S. et al., 'The Global Outbreak Alert and Response Network', *Global Public Health*, 9: 1-17, 2014.

Robert Koch Institute, WHO Collaborating Centre for the Global Outbreak Alert and Response Network – GOARN.

https://www.rki.de/EN/Content/Institute/WHOCC/WHO_CC_GOARN_inhalt.html

[accessed 1 October 2020]

World Health Organization, *Go with GOARN*, 2020.

<https://www.youtube.com/watch?v=FqyA2w4ITuo>

[accessed 1 October 2020]

World Health Organization, GOARN.

<https://extranet.who.int/goarn/>

[accessed 1 October 2020]

OCHA & UNDAC

Reference:

United Nations Office for the Coordination of Humanitarian Affairs (OCHA), *United Nations Disaster Assessment and Coordination, UNDAC Field Handbook, Seventh Edition*, 2018.

https://www.unocha.org/sites/unocha/files/1823826E_web_pages.pdf

[accessed 30 September 2020]

IASC / UN cluster approach

Updated:

Hanna-Tina Fischer, Robert Koch Institute, Berlin, Germany

References:

Global WASH Cluster.

<https://washcluster.net/about-us>

[accessed 12 September 2020]

Inter-Agency Standing Committee, *IASC Transformative Agenda*, Geneva, 2011 (updated 2020).

<https://interagencystandingcommittee.org/iasc-transformative-agenda>

[accessed 10 September 2020]

World Health Organization, Inter-Agency Standing Committee, *Health Cluster Guide, A practical guide for country-level implementation of the Health Cluster, Provisional Version*, Geneva, 2009.

<https://www.humanitarianresponse.info/sites/www.humanitarianresponse.info/files/documents/files/IASC%20HC%20Guide.pdf>

[accessed 12 September 2020]

UNHCR

References:

United Nations High Commissioner for Refugees.

<https://www.unhcr.org/>

[accessed 12 September 2020]

United Nations High Commissioner for Refugees, *UNHCR-OCHA Note on Mixed Situations Coordination in Practice*, Geneva, 2014.

<https://www.unhcr.org/53679e679.pdf>

[accessed 8 November 2020]

<http://www.coordinationtoolkit.org/?p=456>

[accessed 14 September 2020]

United Nations High Commissioner for Refugees, *UNHCR Refugee Coordination Model, Adaptation of UNHCR's refugee coordination in the context of the Transformative Agenda*, Geneva, 2014.

<https://www.unhcr.org/excom/icm/53679e2c9/unhcr-refugee-coordination-model.html>

[accessed 14 September 2020]

United Nations High Commissioner for Refugees, *UNHCR Emergency Handbook, 4th edition*, 2015.

<https://emergency.unhcr.org/>

[accessed 14 November 2020]

United Nations High Commissioner for Refugees, *Refugee Coordination Guidance, Updated Refugee Coordination Guidance Note*, Geneva, 2019.

<https://www.unhcr.org/5d7b50e74.pdf>

[accessed 14 September 2020]

UNICEF

United Nations Children's Fund.

<https://www.unicef.org/>

[accessed 12 September 2020]

WFP

World Food Programme.

<https://www.wfp.org>

[accessed 18 September 2020]

World Food Programme, *12 things you may not know about WFP*, Geneva, 2019.

<https://docs.wfp.org/api/documents/WFP-0000110513/download/>

[accessed 18 September 2020]

UNSGM

Authored by:

Dr Stefan Kloth, Robert Koch Institute, Berlin, Germany

International Red Cross & Red Crescent Movement

Authored by:

Franziska Kellerhaus, German Red Cross, Berlin, Germany

Reference:

German Red Cross, *Training Programme for International Deployments 2020*, Berlin, 2020.

<https://www.drk.de/en/be-involved/training-programme-for-international-deployments-2020/>

[accessed 1 October 2020]

World Bank

References:

Investopedia, *What is the World Bank?*, 2019.

<https://www.investopedia.com/terms/w/worldbank.asp>

[accessed 18 September 2020]

World Bank.

<https://www.worldbank.org/de/about>

[accessed 18 September 2020]

World Bank, *Fact Sheet: Pandemic Emergency Financing Facility*, Washington, 2020.

<https://www.worldbank.org/en/topic/pandemics/brief/fact-sheet-pandemic-emergency-financing-facility>

[accessed 18 September 2020]

Regional organisations

References:

African Union (AU) regional economic communities.

<https://au.int/en/organs/recs>

[accessed 12 September 2020]

Africa CDC

Africa Centres for Disease Control and Prevention (Africa CDC).

<https://africacdc.org/>

[accessed 15 September 2020]

APEC

Asia-Pacific Economic Cooperation (APEC).

<https://www.apec.org/>

[accessed 15 September 2020]

ASEAN

Association of Southeast Asian Nations (ASEAN).

<https://asean.org/>

[accessed 15 September 2020]

European Union

European Union (EU).

https://europa.eu/european-union/about-eu/eu-in-brief_en

[accessed 18 September 2020]

Global health architecture of the European Union

Authored by:

Susan Bergner, German Institute for International and Security Affairs (SWP), Berlin, Germany

References:

Bergner S., 'The EU's Global Health Crisis Management: Past and Present', *E-International Relations*, 2020.

<https://www.e-ir.info/2020/04/17/the-eus-global-health-crisis-management-the-past-the-present/>
[accessed 21 July 2020]

Bergner S., Voss M., 'EU Global Health Policy. An Agenda for the German Council Presidency', *SWP Comment 2020/C 12*, Berlin, 2020.

<https://www.swp-berlin.org/en/publication/eu-global-health-policy/>
[accessed 16 July 2020]

Council of the European Union, *Council conclusions on the EU role in Global Health*, 3011th FOREIGN AFFAIRS Council meeting, Brussels, 2010.

https://www.consilium.europa.eu/uedocs/cms_Data/docs/pressdata/EN/foraff/114352.pdf
[accessed 16 July 2020]

European Commission, EU Civil Protection Mechanism.

https://ec.europa.eu/echo/what/civil-protection/mechanism_en
[accessed 13 November 2020]

European Commission, European Medical Corps.

https://ec.europa.eu/echo/what-we-do/civil-protection/european-medical-corps_en
[accessed 13 November 2020]

European Commission, *Proposal for a REGULATION OF THE EUROPEAN PARLIAMENT AND OF THE COUNCIL on the establishment of a Programme for the Union's action in the field of health – for the period 2021-2027 and repealing Regulation (EU) No 282/2014 ('EU4Health Programme')*, Brussels, 2020.

https://eur-lex.europa.eu/resource.html?uri=cellar:9b76a771-a0c4-11ea-9d2d-01aa75ed71a1.0001.02/DOC_1&format=PDF

[accessed 13 November 2020]

European Union, 'Charter of Fundamental Rights of the European Union', *Official Journal of the European Union*, C 326, volume 55, 391-407, Brussels, 2012.

European Union, 'Consolidated version of the Treaty of the European Union', *Official Journal of the European Union* C326, volume 55, 13-45, Brussels, 2012.

European Union, 'Consolidated version of the Treaty on the Functioning of the European Union', *Official Journal of the European Union* C326, volume 55, 47-199, Brussels, 2012.

European Union, 'Decision No 1082/2013/EU of the European Parliament and of the Council of 22 October 2013 on serious cross-border threats to health and repealing Decision No 2119/98/EC', *Official Journal of the European Union*, volume 56, 1-15, Brussels, 2013.

<https://eur-lex.europa.eu/legal-content/EN/TXT/PDF/?uri=CELEX:32013D1082&from=EN>

[accessed 8 November 2020]

European Union, *Shared Vision, Common Action: A Stronger Europe, A Global Strategy for the European Union's Foreign and Security Policy*, Brussels, 2016.

https://eeas.europa.eu/sites/eeas/files/eugs_review_web_0.pdf

[accessed 16 July 2020]

European Union, 'Consolidated version of the Treaty on the Functioning of the European Union, Article 168', *Official Journal* 115, 09/05/2008 P.0122-0124, Brussels, 2008.

<https://eur-lex.europa.eu/LexUriServ/LexUriServ.do?uri=CELEX:12008E168:EN:HTML>

[accessed 14 November 2020]

European Union, 'Consolidated Version of the Treaty on European Union', *Official Journal of the European Union*, C 326/15, Brussels 2012.

https://eur-lex.europa.eu/resource.html?uri=cellar:2bf140bf-a3f8-4ab2-b506-fd71826e6da6.0023.02/DOC_1&format=PDF

[accessed 14 November 2020]

European Union Agency for Fundamental Rights, *The European Union Charter of Fundamental Rights, Article 35 – Health care*, Vienna.

<https://fra.europa.eu/en/eu-charter/article/35-health-care>

[accessed 14 November 2020]

Immenkamp B., *A new neighbourhood, development and international cooperation instrument*, European Parliament Research Service, Brussels, 2019.

Lilyanova V., *Financing EU external action in the new MFF, 2021-2027, Heading 6 'Neighbourhood and the World'*, European Parliament Research Service, Brussels, 2019.

European Centre for Disease Prevention and Control

Authored by:

Dr Christian H. Winter MScIH DTMPH, Robert Koch Institute, Berlin, Germany

References:

European Centre for Disease Prevention and Control, *ECDC international relations policy 2020*, Stockholm, 2018.

https://www.ecdc.europa.eu/sites/default/files/documents/ECDC%20International%20Relations%20Policy%202020-FINAL_1.pdf

[accessed 1 October 2020]

Haussig J.M. et al., 'The European Medical Corps: first Public Health Team mission and future perspectives', *Eurosurveillance*, Vol. 22, No. 37, European Centre for Disease Prevention and Control, Stockholm, 2017.

<https://doi.org/10.2807/1560-7917.ES.2017.22.37.30613>

[accessed 1 October 2020]

Pacific Islands Forum Secretariat

<https://www.forumsec.org/>

[accessed 15 September 2020]

Shanghai Cooperation Organization (SCO)

<http://www.sectSCO.org/>

[accessed 15 September 2020]

South Asian Association for Regional Cooperation (SAARC)

<https://www.saarc-sec.org/>

[accessed 15 September 2020]

National-level health systems

Health systems and public health institutions

Authored by:

Anne Bergh, Norwegian Institute of Public Health, Oslo, Norway

References:

Centers for Disease Control and Prevention.

<https://www.cdc.gov/globalhealth/countries/default.htm>

[accessed 1 October 2020]

The International Association of National Public Health Institutes.

<https://IANPHI.org/about/index.html>

[accessed 1 October 2020]

The International Association of National Public Health Institutes, *National Public Health Institutes Core Functions & Attributes*.

<http://ianphi.org/includes/documents/sections/tools-resources/ianphi-core-functions-and-attributes.pdf>

[accessed 1 October 2020]

Organization for Economic Co-operation and Development, *Official Development Assistance 2019, Preliminary Data*, Paris, 2019.

https://public.tableau.com/views/ODA-GNI_15868746590080/ODA2019?:display_count=y&publish=yes&:origin=viz_share_link?&:showVizHome=no#1

[accessed 1 October 2020]

<http://www.oecd.org/dac/financing-sustainable-development/development-finance-data/>

[accessed 8 November 2020]

World Health Organization, *Public Spending on health: A Closer Look at Global Trends*, Geneva, 2018.

https://www.who.int/health_financing/documents/health-expenditure-report-2018/en/

[accessed 8 November 2020]

CDC

<https://www.cdc.gov/>

[accessed 12 September 2020]

Robert Koch Institute

https://www.rki.de/EN/Content/Institute/Mission_Statement/Mission_Statement_node.html

[accessed 18 September 2020]

STAKOB

Authored by:

Dr Bettina Ruehe,

Robert Koch Institute, Berlin, Germany

René Gottschalk, CMO, Health Protection Authority,
Frankfurt/Main, Germany

Timo Wolf, MD, University Hospital Frankfurt, Germany

Public Health England / National Institute for Health Protection

‘Public Health England is axed in favour of new health protection agency’, *BMJ* 2020;370:m3257, London, 2020.

<https://www.bmj.com/content/370/bmj.m3257>

[accessed 12 September 2020]

Armed forces medical services

Authored by:

Samuel T. Boland, London School of Hygiene and Tropical Medicine, London, UK

References:

United Nations Office for the Coordination of Humanitarian Affairs, *Guidelines on the Use of Military and Civil Defence Assets to Support United Nations Humanitarian Activities in Complex Emergencies*, March 2003, Revision I, January 2006, Geneva, 2006.

<https://www.unocha.org/publication/guidelines-use-military-and-civil-defence-assets-support-united-nations-humanitarian>

[accessed 8 November 2020]

United Nations Office for the Coordination of Humanitarian Affairs, *Oslo Guidelines, Guidelines on the Use of Foreign Military and Civil Defence Assets in Disaster Relief*, Revision 1.1, Geneva, 2007.

[https://www.unocha.org/sites/unocha/files/OSLO%20](https://www.unocha.org/sites/unocha/files/OSLO%20Guidelines%20Rev%201.1%20-%20Nov%2007.pdf)

[Guidelines%20Rev%201.1%20-%20Nov%2007.pdf](https://www.unocha.org/sites/unocha/files/OSLO%20Guidelines%20Rev%201.1%20-%20Nov%2007.pdf)

Global partnerships, philanthropists, NGOs and non-state actors

The Coalition for Epidemic Preparedness Innovations

<https://cepi.net/>

[accessed 12 September 2020]

Gavi, The Vaccine Alliance

<https://www.gavi.org/>

[accessed 12 September 2020]

The Global Fund to Fight AIDS, Tuberculosis and Malaria

<https://www.theglobalfund.org/en/>
[accessed 12 September 2020]

CDC Foundation

Authored by:

Samuel T. Boland, London School of Hygiene and Tropical
Medicine, London, UK

UN Foundation

<https://unfoundation.org/>
[accessed 18 September 2020]

Wellcome Trust

<https://wellcome.ac.uk/about-us>
[accessed 18 September 2020]

Bill & Melinda Gates Foundation

<https://www.gatesfoundation.org/>
[accessed 12 September 2020]

Médecins Sans Frontières

<https://www.msf.org/>
[accessed 18 September 2020]

Médecins du Monde

<https://www.medecinsdumonde.org/en/about-us>
[accessed 18 September 2020]

Amref

<https://amref.org/>
[accessed 18 September 2020]

International Medical Corps

<https://internationalmedicalcorps.org/who-we-are/>
[accessed 18 September 2020]

Armed non-state actors

Authored by:

Samuel T. Boland, London School of Hygiene and Tropical Medicine, London, UK

Chapter 2

Ethics and morality

Authored by:

Prof. Dr Ole Döring, Berlin Institute for Global Health, Germany
Dr Barbara Buchberger MPH, Robert Koch Institute, Berlin, Germany

References:

Stolper M., Molewijk B., Widdershoven G., 'Bioethics education in clinical settings: theory and practice of the dilemma method of moral case deliberation', *BMC Medical Ethics* 17, 45, Springer Nature, London, 2016.

<https://www.ncbi.nlm.nih.gov/pmc/articles/PMC4957934/>
[accessed 30 July 2020]

Ethics in health emergencies

Authored by:

Prof. Jimmy Whitworth, London School of Hygiene and Tropical Medicine, London, UK

International health regulations

Authored by:

Ariane Halm, Robert Koch Institute, Berlin, Germany

References:

World Health Organization, *International Health Regulations, Third Edition*, Geneva, 2005.

<https://www.who.int/ihr/publications/9789241580496/en/>
[accessed 13 November 2020]

World Health Organization, *WHO Guidance for the use of Annex 2 of the International Health Regulations (2005), Decision instrument for the assessment and notification of events that may constitute a public health emergency of international concern*, Geneva, 2008.

https://www.who.int/ihr/publications/annex_2_guidance/en/
[accessed 13 November 2020]

World Health Organization, *International Health Regulations, Third Edition, IHR monitoring and evaluation framework*, Geneva, 2018.

<https://www.who.int/ihr/publications/WHO-WHE-CPI-2018.51/en/>
[accessed 13 November 2020]

Dual use**Authored by:**

Dr Janine Dywicki, Robert Koch Institute, Berlin, Germany

Dr Iris Hunger, Robert Koch Institute, Berlin, Germany

References:

The Australia Group.

<https://www1.defence.gov.au/business-industry/export/controls>
[accessed 13 November 2020]

Bakanidze L., Imnadze P. and Perkins D., 'Biosafety and biosecurity as essential pillars of international health security and cross-cutting elements of biological nonproliferation', *BMC Public Health*, 10, S12, Springer Nature, London, 2010, pp. 1-8.

Carus W. S., *A Short History of Biological Warfare: From Pre-History to the 21st Century, Occasional Paper 12*, Center for the Study of Weapons of Mass Destruction, National Defense University Press, Washington, 2017.

https://ndupress.ndu.edu/Portals/68/Documents/occasional/cswmd/CSWMD_OccasionalPaper-12.pdf

[accessed 13 November 2020]

The Council of the European Union, *Council Regulation (EC) No 428/2009 of 5 May 2009 setting up a Community regime for the control of exports, transfer, brokering and transit of dual-use items*, Brussels, 2009, pp. IC351-IC354, 2B352.

<https://eur-lex.europa.eu/LexUriServ/LexUriServ.do?uri=OJ:L:2009:134:0001:0269:en:PDF>

[accessed 13 November 2020]

European Committee for Standardization (CEN), *Laboratory biorisk management standard*, CWA 15793:2011, Brussels, 2011.

McLeish C., Nightingale P., 'The Impact of Dual Use Controls on UK Science: Results from a Pilot Study', *SPRU Working Paper Series 132*, Science Policy Research Unit, University of Sussex Business School, Brighton, 2005.

<https://ideas.repec.org/p/sru/ssewps/132.html>

[accessed 13 November 2020]

National Institutes of Health (NIH), US Government, *Tools for the Identification, Assessment, Management, and Responsible Communication of Dual Use Research of Concern - A Companion Guide to the United States Government Policies for Oversight of Life Sciences Dual Use Research of Concern*, Bethesda, 2014.

<https://www.phe.gov/s3/dualuse/Documents/durc-companion-guide.pdf>

[accessed 3 November 2020]

Noyce R. S., Lederman S., Evans D. H., 'Construction of an infectious horsepox virus vaccine from chemically synthesized DNA fragments', *PLOS ONE* 13(1): e0188453, Public Library of Science, San Francisco, 2018.

<https://doi.org/10.1371/journal.pone.0188453>

Organisation for the Prohibition of Chemical Weapons, *The Convention on the Prohibition of the Development, Production, Stockpiling and Use of Chemical Weapons and on their Destruction*, The Hague, 1997.

<https://www.opcw.org/chemical-weapons-convention>
[accessed 13 November 2020]

Puro V. et al., 'Biosecurity Measures in 48 Isolation Facilities Managing Highly Infectious Diseases', *Biosecurity and Bioterrorism: Biodefense Strategy, Practice and Science*, vol. 10, no. 2, Mary Ann Liebert, Inc., New York, 2012, pp. 208–214.

Tucker J. B. (Ed.), *Toxic Terror: Assessing Terrorist Use Of Chemical and Biological Weapons*, MIT Press, 2000.

United Nations, *The Biological Weapons Convention on the Prohibition of the Development, Production and Stockpiling of Bacteriological (Biological) and Toxin Weapons and on their Destruction*, New York 1975.

<https://www.un.org/disarmament/wmd/bio/>
[accessed 13 November 2020]

United Nations, *Security Council Resolution 1540*, New York, 2004.
<https://www.un.org/disarmament/wmd/sc1540/>
[accessed 13 November 2020]

Whitby S., Novossiolova T., Walther G. and Dando M., *Preventing Biological Threats: What You Can Do. A Guide to Biological Security Issues and How to Address Them*, Bradford Disarmament Research Centre, University of Bradford, 2015.

World Health Organization, *Biorisk management, Laboratory biosecurity guidance*, Geneva, 2006.

<https://apps.who.int/iris/handle/10665/69390>
[accessed 13 November 2020]

World Health Organization, *Responsible life sciences research for global health security - A guidance document*, Geneva, 2010.

Sustainable Development Goals (SDGs) and SDG 3

Authored by:

Maike Voss, German Institute for International and Security Affairs (SWP), Berlin, Germany

References:

United Nations, Sustainable Development Goals (SDGs).

<https://sdgs.un.org/2030agenda>

[accessed 13 November 2020]

United Nations, Sustainable Development Summit 2015.

<https://sustainabledevelopment.un.org/post2015/summit>

[accessed 13 November 2020]

The right to health and health equity

Authored by:

Hanna-Tina Fischer, Robert Koch Institute, Berlin, Germany

References:

GBD Causes of Death Collaborators (2017), 'Global, regional, and national age-sex-specific mortality for 282 causes of death in 195 countries and territories, 1980–2017: a systematic analysis for the Global Burden of Disease Study 2017', *The Lancet*, 392:1736–1788.

GBD Mortality Collaborators (2017). 'Global, regional, and national age-sex-specific mortality and life expectancy, 1950–2017: a systematic analysis for the Global Burden of Disease Study 2017', *The Lancet*, 392:1684–1735.

Office of the High Commissioner for Human Rights, *The Right to Health, Fact Sheet No. 31*, United Nations, Geneva, 2008.

<https://www.ohchr.org/Documents/Publications/Factsheet31.pdf>

Office of the High Commissioner for Human Rights, *CESCR General Comment No. 14: The Right to the Highest Attainable Standard of Health (Art. 12)*, United Nations, Geneva, 11 August 2000.

<https://www.refworld.org/docid/4538838d0.html>

[accessed 4 October 2020]

United Nations, *The Universal Declaration of Human Rights*, Paris, 1948.

<https://www.un.org/en/universal-declaration-human-rights/>

World Health Organization, *Constitution of the World Health Organization*, Geneva, 1946.

World Health Organization, *Closing the gap in a generation: Health equity through action on the social determinants of health, Final Report of the Commission on Social Determinants of Health*, Geneva, 2008.

<https://www.who.int/publications/i/item/WHO-IER-CSDH-08.1>

[accessed 3 November 2020]

World Health Organization, *Mortality and global health estimates*

<https://www.who.int/data/gho/data/themes/mortality-and-global-health-estimates>

[accessed 14 November 2020]

Child protection

Authored by:

Hanna-Tina Fischer, Robert Koch Institute, Berlin, Germany

References:

Alliance for Child Protection in Humanitarian Action, *Minimum Standards for Child Protection in Humanitarian Action, 2019 Edition*, Geneva, 2019.

Hillis S., Mercy J., Amobi A. and Kress H., 'Global Prevalence of Past-year Violence Against Children: A Systematic Review and Minimum Estimates', *Pediatrics*, 137(3), e20154079, American Academy of Pediatrics, Itasca, 2016.

<https://pediatrics.aappublications.org/content/early/2016/01/25/peds.2015-4079>

[accessed 14 November 2020]

Perezniето P., Montes A., Routier S., Langston L. and the Child Fund Alliance, *The costs and economic impact of violence against children*, Overseas Development Institute, London, 2014.

https://www.childfund.org/uploadedFiles/public_site/media/ODI%20Report%20%20The%20cost%20and%20economic%20impact%20of%20violence%20against%20children.pdf

[accessed 3 November 2020]

World Health Organization, *Global status report on preventing violence against children 2020*, Geneva, 2020.

<https://www.who.int/publications/i/item/9789240004191>

[accessed 9 November 2020]

Biological and chemical weapons conventions

Authored by:

Maria Hecht, Robert Koch Institute, Berlin, Germany

References:

Organisation for the Prohibition of Chemical Weapons, *The Convention on the Prohibition of the Development, Production, Stockpiling and Use of Chemical Weapons and on their Destruction*, The Hague, 1997.

<https://www.opcw.org/chemical-weapons-convention>

[accessed 14 November 2020]

United Nations, *Protocol for the Prohibition of the Use in War of Asphyxiating, Poisonous or Other Gases, and of Bacteriological Methods of Warfare*, Geneva, 1925.

<https://www.un.org/disarmament/wmd/bio/1925-geneva-protocol/>

[accessed 14 November 2020]

United Nations, *The Biological Weapons Convention on the Prohibition of the Development, Production and Stockpiling of Bacteriological (Biological) and Toxin Weapons and on their Destruction*, New York, 1975.

<https://www.un.org/disarmament/wmd/bio/>
[accessed 14 November 2020]

United Nations, *Security Council Resolution 1540*, New York, 2004.
<https://www.un.org/disarmament/wmd/sc1540/>
[accessed 14 November 2020]

Gender

References:

Saferworld, *Gender analysis of conflict toolkit*, London, 2016.
<https://www.saferworld.org.uk/resources/publications/1076-gender-analysis-of-conflict>
[accessed 10 November 2020]

UN Women, Definition of gender.
<https://www.un.org/womenwatch/osagi/conceptsans.htm>
[accessed 8 October 2020]

Sexual exploitation and abuse

References:

Inter-Agency Standing Committee, *IASC Six Core Principles Relating to Sexual Exploitation and Abuse*, Geneva, 2019
https://interagencystandingcommittee.org/system/files/iasc_six_core_principles_relating_to_sexual_exploitation_and_abuse_sept_2019.pdf
[accessed on 10 November 2020]

United Nations, *Security Council Resolution 2272 on Sexual Exploitation and Abuse*, New York, 2016.

United Nations, *Glossary on Sexual Exploitation and Abuse, 2nd Edition*, 2017.

United Nations, *Report of the Secretary-General: Special measures for protection from sexual exploitation and abuse*, New York, 2018.

Chapter 3

Anthropological perspectives in health emergencies

Authored by:

Prof. Dr Hansjörg Dilger, Freie Universität Berlin, Germany

Dr Sung-Joon Park, Martin-Luther-Universität Halle-Wittenberg, Germany

Anthropologists in health emergencies

Authored by:

Prof. Heidi J Larson PhD, London School of Hygiene and Tropical Medicine, UK

Biosafety and biosecurity

Authored by:

Dr Jana Wolf, Robert Koch Institute, Berlin, Germany

References:

Bakanidze L. et al., 'Biosafety and Biosecurity as Essential Pillars of International Health Security and Cross-Cutting Elements of Biological Non-Proliferation', *BMC Public Health*, Vol.10:1. [online], 2010.

<https://bmcpublikealth.biomedcentral.com/articles/10.1186/1471-2458-10-S1-S12>

[accessed 18 August 2020]

Clevestig P., *Handbook of applied biosecurity for life science laboratories*, Stockholm International Peace Research Institute (SIPRI), 2009.

<https://www.sipri.org/sites/default/files/files/misc/SIPRI09HAB.pdf>

[accessed 18 August 2020]

European Committee for Standardization (CEN), *Laboratory Biorisk Management Standard*, CWA 15793, Brussels, 2011.

European Committee for Standardization (CEN), *Laboratory biorisk management – Guidelines for the implementation of CWA 15793:2008*, CWA 16393, Brussels, 2012.

<https://www.cdc.gov.tw/Uploads/files/201504/d0feebf2-a92c-46e1-914a-b9d1435bc52f.pdf>

[accessed 6 November 2020]

Government of Canada, *Canadian Biosafety Standard, Second Edition*, Ottawa, 2015.

<https://www.canada.ca/en/public-health/services/canadian-biosafety-standards-guidelines/second-edition.html>

[accessed 6 November 2020]

Government of Canada, *Canadian Biosafety Handbook, Second Edition*, Ottawa, 2016.

<https://www.canada.ca/en/public-health/services/canadian-biosafety-standards-guidelines/handbook-second-edition.html>

[accessed 6 November 2020]

Gronvall G. K., Rozo M., *Synopsis of Biological Safety and Security Arrangements*, UPMC Center for Health Security, 2015.

https://www.centerforhealthsecurity.org/our-work/pubs_archive/pubs-pdfs/2015/SynopsisofBiologicalSafetyandSecurityArrangements-112915.pdf

[accessed 18 August 2020]

Sandia National Laboratories, *Laboratory Biosafety and Biosecurity Risk Assessment Technical Guidance Document*, 2014.

<https://prod-ng.sandia.gov/techlib-noauth/access-control.cgi/2014/1415939r.pdf>

[accessed 18 August 2020]

U.S. Department of Health and Human Services, Public Health Service, Centers for Disease Control and Prevention, National Institutes of Health, *Biosafety in Microbiological and Biomedical Laboratories, 5th Edition*, 2009.

<https://www.cdc.gov/labs/pdf/CDC-BiosafetyMicrobiologicalBiomedicalLaboratories-2009-P.PDF>

[accessed 18 August 2020]

World Health Organization, *Laboratory Biosafety Manual, Third Edition*, Geneva, 2004.

<http://www.who.int/csr/resources/publications/biosafety/en/Biosafety7.pdf>

[accessed 18 August 2020]

World Health Organization, *Biorisk Management: Laboratory Biosecurity Guidance*, Geneva, 2006.

http://www.who.int/csr/resources/publications/biosafety/WHO_CDS_EPR_2006_6.pdf?ua=1

[accessed 18 August 2020]

World Health Organization, *Laboratory Assessment Tool*, Geneva, 2012.

http://www.who.int/ihr/publications/laboratory_tool/en/

[accessed 18 August 2020]

Clinical facilities and management

Authored by:

Dr Gerald Ripberger, Robert Koch Institute, Berlin, Germany

References:

Cordner S. et al., (eds.), *Management of Dead Bodies after Disasters: A Field Manual for First Responders, Second Edition*, Pan American Health Organization, World Health Organization, International Committee of the Red Cross, International Federation of Red Cross and Red Crescent Societies, Geneva, 2016.

<https://www.who.int/hac/techguidance/management-of-dead-bodies/en/>

<https://iris.paho.org/bitstream/handle/10665.2/31295/9789275319246-eng.pdf?sequence=1&isAllowed=y&ua=1>
[accessed 4 November 2020]

U.S. Department of Health and Human Services, Centers for Disease Control and Prevention (CDC), *Public Health Emergency Preparedness and Response Capabilities: National Standards for State, Tribal, Local, and Territorial Public Health*, 2018, updated 2019.
https://www.cdc.gov/cpr/readiness/00_docs/CDC_PreparednessResponseCapabilities_October2018_Final_508.pdf
[accessed 4 November 2020]

World Health Organization, Essential medicines and health products.
<https://www.who.int/medicines/publications/en/>
[accessed 14 November 2020]

World Health Organization, Health care waste.
https://www.who.int/water_sanitation_health/facilities/waste/en/
[accessed 14 November 2020]

World Health Organization, Inter-Agency Standing Committee, Global Health Cluster, *Health Resources Availability Mapping System (HeRams)*, Geneva, 2014.
https://www.who.int/hac/network/global_health_cluster/herams_serviceschecklist_2014.pdf?ua=1
[accessed 4 November 2020]

Communication Part 1: Infodemics and misinformation

Authored by:

Christopher Burke, WMC Africa, Kampala, Uganda

References:

The World Bank, *Connecting for Inclusion: Broadband Access for All*, Washington, 2020.
<https://www.worldbank.org/en/topic/digitaldevelopment/brief/connecting-for-inclusion-broadband-access-for-all>
[accessed 13 October 2020]

Communication Part 2: Guiding principles of community engagement and risk communication

Authored by:

Dr Heide Weishaar, Robert Koch Institute, Berlin, Germany

Dr Almudena Marí-Sáez, Robert Koch Institute, Berlin, Germany

Reference:

World Health Organisation

<https://www.who.int/risk-communication/guidance/download/en/>

[accessed 14 November 2020]

Communication Part 3 Information management and visualisation

Authored by:

Matt Sims, MapAction, Chinnor, UK

Alan Mills, MapAction, Chinnor, UK

References:.

ACAPS, COVID-19 Government measures

[https://experience.arcgis.com/experience/](https://experience.arcgis.com/experience/afd0a414d5c24f11b3de4fc7f7360225)

[afd0a414d5c24f11b3de4fc7f7360225](https://experience.arcgis.com/experience/afd0a414d5c24f11b3de4fc7f7360225)

[accessed 14 November 2020]

MapAction, Clusters / Emergency Medical Teams.

<https://guides.mapaction.org/clusters-emergency-medical-teams>

[accessed 14 November 2020]

MapAction, Health systems.

<https://guides.mapaction.org/health-systems>

[accessed 14 November 2020]

MapAction, Morbidity and mortality.

<https://guides.mapaction.org/morbidity-mortality>

[accessed 14 November 2020]

Digitalisation of health and health responses

Authored by:

Dr Sandra Beermann, Robert Koch Institute, Berlin, Germany

Patrick Schmich, Robert Koch Institute, Berlin, Germany

References:

District Health Information Software 2 (DHIS2).

<https://www.dhis2.org/about>

[accessed 13 November 2020]

McCarthy N., 'Which Countries Are Deploying Coronavirus Tracing Apps?', Statista, 27 July 2020.

<https://www.statista.com/chart/22335/development-of-tracing-apps-by-country/>

[accessed 13 November 2020]

O'Neill P.H., Ryan-Mosley T., Johnson B., 'A flood of coronavirus apps are tracking us. Now it's time to keep track of them', *MIT Technology Review*, 7 May 2020.

<https://www.technologyreview.com/2020/05/07/1000961/launching-mittr-covid-tracing-tracker/>

[accessed 13 November 2020]

The Surveillance, Outbreak Response Management and Analysis System (SORMAS).

<https://sormasorg.helmholtz-hzi.de/>

[accessed 13 November 2020]

United Nations, Secretariat of the Convention on Biological Diversity, *The Nagoya Protocol on Access to Genetic Resources and the Fair and Equitable Sharing of Benefits Arising from their Utilization to the Convention on Biological Diversity*, Montreal, 2011.

<https://www.cbd.int/abs/doc/protocol/nagoya-protocol-en.pdf>

[accessed 13 November 2020]

World Health Organization, Early Warning Alert and Response System (EWARS).

<https://www.who.int/emergencies/surveillance/early-warning-alert->

and-response-system-ewars
[accessed 13 November 2020]

World Health Organization, Go Data.
<https://www.who.int/godata>
[accessed 13 November 2020]

Environmental risks and climate extremes

Authored by:

Dr Luzie Verbeek, Robert Koch Institute, Berlin, Germany

References:

Smith K.R. et al., 'Human Health: Impacts, Adaptation, and Co-Benefits', *Climate Change 2014: Impacts, Adaptation, and Vulnerability. Part A: Global and Sectoral Aspects. Contribution of Working Group II to the Fifth Assessment Report of the Intergovernmental Panel on Climate Change*, Cambridge University Press, Cambridge, UK and New York, USA, 2014, pp. 709-754.
https://www.ipcc.ch/site/assets/uploads/2018/02/WGIIAR5-Chap11_FINAL.pdf

[accessed 5 November 2020]

United Nations Office for Disaster Risk Reduction, *Global Assessment Report on Disaster Risk Reduction 2019*, Geneva, 2019.
<https://www.undrr.org/publication/global-assessment-report-disaster-risk-reduction-2019>

[accessed 5 November 2020]

World Health Organization, Climate change.
https://www.who.int/health-topics/climate-change#tab=tab_1

World Meteorological Organization, *The Global Climate in 2015-2019*, WMO-No. 1249, Geneva, 2020.

https://library.wmo.int/doc_num.php?explnum_id=10251

[accessed 5 November 2020]

World Meteorological Organization, *WMO Statement on the State of the Global Climate in 2019*, WMO-No. 1248, Geneva, 2020.

https://library.wmo.int/doc_num.php?explnum_id=10211

[accessed 5 November 2020]

Environmental health in emergencies

Authored by:

James Brown, Oxfam, Oxford, UK

References:

Action contre la Faim (ACF), *Water, sanitation and hygiene for populations at risk*, Hermann, Paris, 2005.

https://www.actionagainsthunger.org/sites/default/files/publications/Water_sanitation_and_hygiene_for_populations_at_risk_12.2005.pdf

[accessed 5 November]

GDB 2016 Diarrhoeal Disease Collaborators, 'Estimates of the global, regional, and national morbidity, mortality, and aetiologies of diarrhoea in 195 countries: a systematic analysis for the Global Burden of Disease Study 2016', *The Lancet Infectious Diseases*, 2018, 18:2011-2028.

[https://www.thelancet.com/journals/laninf/article/PIIS1473-3099\(18\)30362-1/fulltext](https://www.thelancet.com/journals/laninf/article/PIIS1473-3099(18)30362-1/fulltext)

[accessed 5 November 2020]

Global Wash Cluster.

<http://www.washcluster.net/>

Prüss-Ustün A. et al., *Preventing disease through healthy environments: a global assessment of the burden of disease from environmental risks*, World Health Organization, Geneva, 2016.

https://www.who.int/quantifying_ehimpacts/publications/preventing-disease/en/

[accessed 5 November 2020]

World Health Organization, Diarrhoeal disease.

<https://www.who.int/news-room/fact-sheets/detail/diarrhoeal-disease>

[accessed 13 October 2020]

Epidemiology

Authored by:

Dr Tim Eckmanns, Robert Koch Institute, Berlin, Germany

Epidemiological surveillance

Authored by:

Dr Jan Walter, Robert Koch Institute, Berlin, Germany

Ariane Halm, Robert Koch Institute, Berlin, Germany

References:

Bonita R., Beaglehole R., Kjellström T., *Basic epidemiology, 2nd edition*. World Health Organization, Geneva, 2006.

https://apps.who.int/iris/bitstream/handle/10665/43541/9241547073_eng.pdf?sequence=1

[accessed 10 November 2020]

Centers for Disease Control and Prevention, *Updated Guidelines for Evaluating Public Health Surveillance Systems, Recommendations from the Guidelines Working Group*, Atlanta, 2001.

<https://www.cdc.gov/mmwr/preview/mmwrhtml/rr5013a1.htm>

[accessed 10 November 2020]

Klaucke D.N. et al., 'Guidelines for Evaluating Surveillance Systems', *Morbidity and Mortality Weekly Report (MMWR)*, 37(S-5);1-18, Centers for Disease Control and Prevention, Atlanta, 1988.

World Health Organization, *Outbreak surveillance and response in humanitarian emergencies, WHO guidelines for EWARN implementation*, Geneva, 2012.

https://apps.who.int/iris/bitstream/handle/10665/70812/WHO_HSE_GAR_DCE_2012_1_eng.pdf?sequence=1

[accessed 10 November 2020]

World Health Organization Regional Office for Africa, *Technical Guidelines for Integrated Disease Surveillance and Response in the WHO African Region: Third edition*, Brazzaville, 2019.

<https://www.afro.who.int/publications/technical-guidelines-integrated-disease-surveillance-and-response-african-region-third>
[accessed 10 November 2020]

Healthcare in fragile settings

Authored by:

Samuel T. Boland, London School of Hygiene and Tropical Medicine, London, UK

Health practices and quality of health care

Authored by:

Thomas Cotter MPH, Project HOPE, Bethesda, USA

Vlatko Uzhevski MD, Project HOPE, Bethesda, USA

References:

International Committee of the Red Cross, *Management of limb injuries during disasters and conflicts*, Geneva, 2016.

https://www.aofoundation.org/-/media/project/aocmf/aof/documents/icrc/a_field_guide_low_res.pdf

[accessed 28 October 2020]

International Committee of the Red Cross, *Handbook on data protection in humanitarian action, Second Edition*, Geneva, 2020.

<https://www.icrc.org/en/data-protection-humanitarian-action-handbook>

[accessed 6 November 2020]

Médecins Sans Frontières, *Clinical guidelines – Diagnosis and treatment manual*, Paris, 2020.

<https://medicalguidelines.msf.org/viewport/CG/english/clinical-guidelines-16686604.html>

[accessed 14 November 2020]

Médecins Sans Frontières, *Essential Drugs*, Paris, 2020.
<https://medicalguidelines.msf.org/viewport/EssDr/english/essential-drugs-16682376.html>

[accessed 14 November 2020]

Sphere Association, *The Sphere Handbook: Humanitarian Charter and Minimum Standards in Humanitarian Response, Fourth Edition*, Geneva, 2018.

<https://www.spherestandards.org/handbook-2018/>

[accessed 6 November 2020]

United Nations Statistics Division, *Overview of standards for data disaggregation*, New York, 2018.

[https://unstats.un.org/sdgs/files/Overview of Standards for Data Disaggregation.pdf](https://unstats.un.org/sdgs/files/Overview%20of%20Standards%20for%20Data%20Disaggregation.pdf)

[accessed 6 November]

World Health Organization, *Minimum Data Set for Reporting by Emergency Medical Teams*, Geneva, 2016.

World Health Organization, *Emergency Medical Teams: Minimum Technical Standards and Recommendations for Rehabilitation*, Geneva, 2016.

<https://www.who.int/publications/i/item/emergency-medical-teams>

[accessed 28 October 2020]

World Health Organization, *Emergency Medical Teams: Minimum Technical Standards and Recommendations for Reproductive, Maternal, Newborn, and Child Health Care*, Geneva, 2018.

https://vosocc.unocha.org/GetFile.aspx?file=85502_WHO_Maternal_and_Child_EMT_Master_Working_Document_V28_For_Wider_EMT_Community.pdf

[accessed 6 November 2020]

World Health Organization, *The Red Book: A Guidance Document for Medical Teams Preparing for, & Responding to Armed Conflict & Complex Emergencies. Draft 0*, Geneva, 2018.

https://vosocc.unocha.org/GetFile.aspx?file=85500_The_Red_Book_Draft_0_-_Jan_14.pdf

[accessed 6 November 2020]

Infection Prevention and Control

Authored by:

Sara Tomczyk, Robert Koch Institute, Berlin, Germany

References:

Centers for Disease Control and Prevention, *Guideline for Isolation Precautions: Preventing Transmission of Infectious Agents in Healthcare Settings*, Atlanta, 2007.

Damani N., *Manual of Infection Prevention and Control*, Oxford University Press, Oxford, 2019.

European Centre for Disease Prevention and Control, *Operational guidance on rapid risk assessment methodology*, Stockholm, 2011.
https://www.ecdc.europa.eu/sites/default/files/media/en/publications/Publications/1108_TED_Risk_Assessment_Methodology_Guidance.pdf
[accessed 14 November 2020]

Luangasanatip N. et al., 'Comparative efficacy of interventions to promote hand hygiene in hospital: systematic review and network meta-analysis'. *BMJ*, 351:p.h3728, London, 2015.

Storr J. et al., *Core components for effective infection prevention and control programmes: new WHO evidence-based recommendations*, World Health Organization, Geneva, 2017.
<https://pubmed.ncbi.nlm.nih.gov/28078082/>
[accessed 14 November 2020]

World Health Organization. *Infection control standard precautions in health care*, Geneva, 2006.
https://www.who.int/csr/resources/publications/4EPR_AM2.pdf
[accessed 14 November 2020]

World Health Organization. *My 5 Moments for Hand Hygiene*, Geneva, 2007.
<https://www.who.int/infection-prevention/campaigns/clean-hands/5moments/en/>.
[accessed 14 November 2020]

World Health Organization, *IPC Guidance Summary Ebola guidance package*, Geneva, 2014.

World Health Organization, *Guidelines on Core Components of Infection Prevention and Control Programmes at the National and Acute Health Care Facility Level*, Geneva, 2016.

<https://apps.who.int/iris/handle/10665/251730>

[accessed 6 November 2020]

World Health Organization, *Infection Prevention and Control Assessment Tool 2 (IPCAT2)*, Geneva, 2017.

<https://www.who.int/infection-prevention/tools/core-components/en/>.

[accessed 14 November 2020]

World Health Organization, *Infection Prevention and Control Assessment Framework at the Facility Level (IPCAF)*, Geneva, 2018.

<https://www.who.int/infection-prevention/tools/core-components/IPCAF-facility.PDF>

[accessed 14 November 2020]

World Health Organization, *Minimum requirements for infection prevention and control programmes*, Geneva, 2019.

<https://www.who.int/infection-prevention/publications/min-req-IPC-manual/en/>

[accessed 14 November 2020]

World Health Organization, *WHO multimodal improvement strategy*, Geneva 2019.

<https://www.who.int/infection-prevention/publications/ipc-cc-mis.pdf?ua=1>

[accessed 14 November 2020]

World Health Organization, *Minimum Requirements for infection prevention and control (IPC) programmes*, Geneva, 2019.

<https://www.who.int/infection-prevention/publications/min-req-IPC-manual/en/>

[accessed 14 November 2020]

World Health Organization, *Infection prevention and control during health care when coronavirus disease (COVID-19) is suspected or confirmed*, Geneva, 2020.

<https://www.who.int/publications/i/item/WHO-2019-nCoV-IPC-2020.4>

[accessed 14 November 2020]

Laboratory facilities and diagnostics

Authored by:

Dr Sabrina Weiss, Robert Koch Institute, Berlin, Germany

World Health Organization, *Laboratory Biosafety Manual, Third Edition*, Geneva, 2004.

<http://www.who.int/csr/resources/publications/biosafety/en/Biosafety7.pdf>

[accessed 18 August 2020]

References:

Wölfel Roman et al., 'Mobile diagnostics in outbreak response, not only for Ebola: a blueprint for a modular and robust field laboratory'. *Euro Surveill.* 2015;20(44):pii=30055.

<https://www.eurosurveillance.org/docserver/fulltext/eurosurveillance/20/44/eurosurv-20-44-5.pdf?expires=1604680618&id=id&acname=guest&checksum=4BB03BA3FD1D83607314DB9E20A65BB2>

[accessed 6 November 2020]

Maximum containment laboratories

Authored by:

Dr Andreas Kurth, Robert Koch Institute, Berlin, Germany

References:

World Health Organization, *Laboratory Biosafety Manual, Third Edition*, Geneva, 2004.

<http://www.who.int/csr/resources/publications/biosafety/en/Biosafety7.pdf>
[accessed 18 August 2020]

Mobile laboratories

Authored by:

Jan Baumann, Robert Koch Institute, Berlin, Germany

References:

World Health Organization, *Guidance for Rapid Response Mobile Laboratories*, Geneva 2019

Medical logistics and supply chain management

Authored by:

Liam Callaghan MPharm, MSc, IPresc, PhD, NHS Western Isles Hospital, Scotland, UK

References:

Kummer Peiry K., *Basel Convention on the Control of Transboundary Movements of Hazardous Wastes and their Disposal*, United Nations, 2010.

https://legal.un.org/avl/pdf/ha/bcctmhwd/bcctmhwd_e.pdf
[accessed 6 November 2020]

World Health Organization, 'Guide to good storage practices for pharmaceuticals', *WHO Technical Report Series, No. 908, Annex 9*, Geneva, 2003.

https://www.who.int/medicines/areas/quality_safety/quality_assurance/GuideGoodStoragePracticesTRS908Annex9.pdf?ua=1
[accessed 6 November 2020]

World Health Organization, 'WHO good distribution practices for pharmaceutical products', *WHO Technical Report Series, No. 957, Annex 5*, Geneva, 2010.

https://www.who.int/medicines/areas/quality_safety/quality_assurance/GoodDistributionPracticesTRS957Annex5.pdf?ua=1
[accessed 6 November 2020]

World Health Organization, 'Model guidance for the storage and transport of time- and temperature-sensitive pharmaceutical products', *WHO Technical Report Series, No. 961, Annex 9*, Geneva, 2011.

https://www.who.int/medicines/areas/quality_safety/quality_assurance/ModelGuidanceForStorageTransportTRS961Annex9.pdf?ua=1
[accessed 6 November 2020]

World Health Organization, 'WHO good manufacturing practices for pharmaceutical products: main principles', *WHO Technical Report Series, No. 986, Annex 2*, Geneva, 2014.

https://www.who.int/medicines/areas/quality_safety/quality_assurance/TRS986annex2.pdf?ua=1
[accessed 6 November 2020]

Medical waste

Authored by:

Sabine Gies PhD MD, Medical Mission Institute Würzburg, Germany

References:

Chartier Y. et al (eds.), *Safe management of wastes from health-care activities, Second edition*, World Health Organization, Geneva, 2014.
https://apps.who.int/iris/bitstream/handle/10665/85349/9789241548564_eng.pdf;jsessionid=51E5732E870B1208ADEF4381E0D6A3B0?sequence=1
[accessed 6 November 2020]

International Committee of the Red Cross, *Medical Waste Management*, Geneva, 2011.
<https://shop.icrc.org/medical-waste-management-pdf-en>
[accessed 6 November 2020]

Sphere Association, *The Sphere Handbook: Humanitarian Charter and Minimum Standards in Humanitarian Response, Fourth Edition*, Geneva, 2018.

<https://www.spherestandards.org/handbook-2018/>

[accessed 6 November 2020]

United Nations Environment Programme, *Compendium of Technologies for Treatment/Destruction of Health care Waste*, Osaka, 2012.

<https://wedocs.unep.org/handle/20.500.11822/8628>

[accessed 6 November 2020]

Van Den Noortgate J., *Health-care waste management in low-income countries*, Médecins Sans Frontières, Paris, 2005 (updated 2006).

[https://bibop.ocg.msf.org/docs/18/L018SANM04E-P_](https://bibop.ocg.msf.org/docs/18/L018SANM04E-P_HealthCarewastemngt.pdf)

[HealthCarewastemngt.pdf](https://bibop.ocg.msf.org/docs/18/L018SANM04E-P_HealthCarewastemngt.pdf)

[accessed 6 November 2020]

World Health Organization, *Safe health-care waste management: Policy paper*, Geneva, 2004.

[http://www.who.int/water_sanitation_health/publications/](http://www.who.int/water_sanitation_health/publications/hcwmpolicy/en/)

[hcwmpolicy/en/](http://www.who.int/water_sanitation_health/publications/hcwmpolicy/en/)

[accessed 6 November 2020]

World Health Organization, *Overview of technologies for the treatment of infectious and sharp waste from health care facilities*, Geneva, 2019.

[https://www.who.int/water_sanitation_health/publications/](https://www.who.int/water_sanitation_health/publications/technologies-for-the-treatment-of-infectious-and-sharp-waste/en/)

[technologies-for-the-treatment-of-infectious-and-sharp-waste/en/](https://www.who.int/water_sanitation_health/publications/technologies-for-the-treatment-of-infectious-and-sharp-waste/en/)

[accessed 6 November 2020]

World Health Organization, *Water, sanitation and hygiene in health care facilities: practical steps to achieve universal access*, Geneva, 2019.

[https://www.who.int/water_sanitation_health/publications/wash-in-](https://www.who.int/water_sanitation_health/publications/wash-in-health-care-facilities/en/)

[health-care-facilities/en/](https://www.who.int/water_sanitation_health/publications/wash-in-health-care-facilities/en/)

[accessed 6 November 2020]

Nutrition in Humanitarian Response

Authored by:

Raof Al Waziza, Institute for Research in International Assistance (IRIA), Akkon University of Applied Sciences, Berlin, Germany

Personal Protective Equipment (PPE)

Authored by:

Mario-Alexander Lehmann, Fire Dept. Juechen, Rhine County of Neuss, Germany

References:

Berufsgenossenschaftliches Institut für Arbeitssicherheit (BIA), *Schutzwirkung von OP-Mundschutz im Vergleich mit Mindestanforderungen des Atemschutzes*, Projekt-Nr. BIA 1067, 1995. https://www.dguv.de/ifa/forschung/projektverzeichnis/bia_1067.jsp [accessed 6 November 2020]

European Union, *Regulation (EU) 2016/425 of the European Parliament and of the Council of 9 March 2016 on personal protective equipment*, Brussels, 2016.

Health and Safety Executive, Government of the United Kingdom, *Guidance on respiratory protective equipment (RPE) - fit testing*, London, 2019.

International Organization for Standardization, *ISO 16975-3:2017 Respiratory protective devices — Selection, use and maintenance — Part 3: Fit-testing procedures*, Geneva, 2017.

Occupational Safety & Health Administration, United States Department of Labor, *OSHA 1910.134 App A - Fit Testing Procedures (Mandatory)*, Washington, 2004.

Roberge R., 'Face shields for infection control: A review', *J. Occup. Environ. Hyg.* 2016;13(4):235-242.

Social distancing and border controls

Authored by:

Prof. Christian Enemark PhD, University of Southampton, UK

Reference:

Enemark C., *Biosecurity Dilemmas: Dreaded Diseases, Ethical Responses, and the Health of Nations*, Georgetown University Press, Washington, 2017.

Vaccination Preparedness

Authored by:

Leesa Lin PhD, London School of Hygiene and Tropical Medicine, London, UK

Prof. Heidi Larson PhD, London School of Hygiene and Tropical Medicine, London, UK

References:

Andre F.E. et al., 'Vaccination greatly reduces disease, disability, death and inequity worldwide'. *Bull World Health Organ*. 2008;86(2):140-146.

Coleman-Mitchell R.D., *Public health committee - Public Hearing*, February 19, 2020.

<https://www.cga.ct.gov/2020/phdata/chr/pdf/2020PH-00219-R011030-CHR.pdf>

[accessed 11 November 2020]

Kwok K.O. et al., 'Herd immunity - estimating the level required to halt the COVID-19 epidemics in affected countries'. *J Infect*. 2020;80(6):e32-e33.

UNICEF, World Health Organization, International Federation of Red Cross and Red Crescent Societies, *Social Stigma associated with COVID-19, A guide to preventing and addressing social stigma*, Geneva, 2020.

<https://www.who.int/publications/i/item/social-stigma-associated-with-covid-19>

[accessed 6 November]

World Health Organization, *More than 140,000 die from measles as cases surge worldwide*, Geneva 2019.

<https://www.who.int/news-room/detail/05-12-2019-more-than-140-000-die-from-measles-as-cases-surge-worldwide>

[accessed 14 November]

Zoonotic infections

Authored by:

Dr Fabian Leendertz, Robert Koch Institute, Berlin

References:

World Health Organization, Zoonoses.

<https://www.who.int/topics/zoonoses/en>

[accessed 1 October 2020]

Chapter 4

Reference:

Lloyd Roberts, David, *Staying Alive: Safety and security guidelines for humanitarian volunteers in conflict areas*, International Committee of the Red Cross, Geneva, 1999 (updated 2005).

https://www.icrc.org/en/doc/assets/files/other/icrc_002_0717.pdf

Chapter 5

Staying healthy

Authored by:

Dr Deike Rosenbusch MPH, German Federal Foreign Office, Berlin, Germany

References:

German Ministry of Foreign Affairs, Travel and safety information.
<https://www.auswaertiges-amt.de/de/ReiseUndSicherheit/reise-und-sicherheitshinweise>

[accessed 14 November 2020]

Lloyd Roberts, David, *Staying Alive: Safety and security guidelines for humanitarian volunteers in conflict areas*, International Committee of the Red Cross, Geneva, 1999 (updated 2005).

https://www.icrc.org/en/doc/assets/files/other/icrc_002_0717.pdf

[accessed 14 November 2020]

World Health Organization, *Oral Rehydration Salts: Production of the new ORS*, Geneva, 2006.

http://whqlibdoc.who.int/hq/2006/WHO_FCH_CAH_06.1.pdf

[accessed 14 November 2020]

World Health Organization, *How to put on and how to remove personal protective equipment (PPE)*, Geneva, 2015.

<https://www.who.int/publications/i/item/WHO-HIS-SDS-2015.1>

[accessed 14 November 2020]

Health advice for those responding to emerging and high consequence infectious diseases

Authored by:

Dr Thomas Kratz, Robert Koch Institute, Berlin, Germany

References:

European Centre for Disease Prevention and Control, *Health emergency preparedness for imported cases of high-consequence infectious diseases*, Stockholm, 2019.

World Health Organization, *A brief guide to emerging infectious diseases and zoonoses*, WHO Regional Office for South-East Asia, 2014.

<https://apps.who.int/iris/handle/10665/204722>

[accessed 14 November 2020]

Mental health and stress management

Authored by:

Martine Bourquin, Lausanne, Switzerland

References:

McKay L., *Understanding & Coping with Traumatic Stress*, Headington Institute, Pasadena, 2007.

https://www.acesdv.org/wp-content/uploads/2014/06/understanding-and-coping-with-traumatic-stress_updated-nov-2014_63458.pdf
[accessed 13 November 2020]

Pearlman L.A., McKay L., *Understanding & Addressing Vicarious Trauma*, Headington Institute, Pasadena, 2008

https://mutualaididasterreliefsite.files.wordpress.com/2017/04/vtmoduletemplate2_ready_v2_85791.pdf
[accessed 13 November 2020]

Substance abuse

Authored by:

Martine Bourquin, Lausanne, Switzerland

Staying safe

Reference:

Lloyd Roberts, David, *Staying Alive: Safety and security guidelines for humanitarian volunteers in conflict areas*, International Committee of the Red Cross, Geneva, 1999 (updated 2005).

https://www.icrc.org/en/doc/assets/files/other/icrc_002_0717.pdf
[accessed 14 November 2020]

Cyber security

Authored by:

Gregor Schaffrath, European Security and Defence College, Brussels, Belgium

Fire safety

Authored by:

Gerard Guerin, ex National Directorate for Fire & Emergency Management, Ireland

Individual protective gear

Updated by:

Lieutenant Colonel (retired) Thomas Enke Dipl. Ing. (TU)

Reference:

Lloyd Roberts, *Staying Alive*

Mines and explosive hazards

Updated by:

Lieutenant Colonel (retired) Thomas Enke Dipl. Ing. (TU)

References:

Lloyd Roberts, *Staying Alive*

United Nations Mine Action Service, *Landmines, Explosive Remnants of War and Improvised Explosive Devices Safety Handbook*, New York, 2015.

https://unmas.org/sites/default/files/handbook_english.pdf
[accessed 14 November 2020]

Chapter 6

Procedures and codes of conduct

Authored by:

Emilio Hornsey, Public Health England and London School of Hygiene and Tropical Medicine, London, UK

References:

- Bromiley M., *Can Standard Operating Procedures work in healthcare?* The Health Foundation, London, 2011.
<https://www.health.org.uk/blogs/can-standard-operating-procedures-work-in-healthcare>
[accessed 12 November 2020]
- The College of Emergency Medicine and The UK Sepsis Trust, *Sepsis: A toolkit for Emergency Departments*, London, 2014, p.13.
<https://www.rcem.ac.uk/docs/Sepsis/Sepsis%20Toolkit.pdf>
[accessed 12 November 2020]
- The International Council for Harmonisation of Technical Requirements for Pharmaceuticals for Human Use (ICH).
<https://www.ich.org/>
[accessed 12 November 2020]
- International Council of Nurses, *The ICN Code of Ethics for Nurses*, Geneva, 2012.
https://www.icn.ch/sites/default/files/inline-files/2012_ICN_Codeofethicsfornurses_%20eng.pdf
[accessed 12 November 2020]
- The Moral Injury Project, Syracuse University, New York State, USA
<https://moralinjuryproject.syr.edu/about-moral-injury/>
[accessed 12 November 2020]
- North Atlantic Treaty Organization, *NATO Standard AJP-4.10, Allied Joint Doctrine for Medical Support, Edition C Version 1*, Brussels, 2019.
https://assets.publishing.service.gov.uk/government/uploads/system/uploads/attachment_data/file/922182/doctrine_nato_med_spt_ajp_4_10.pdf
[accessed 12 November 2020]
- Norton I. et al., *Classification and Minimum Standards for Foreign Medical Teams in Sudden Onset Disasters*, World Health Organization, Geneva, 2013.

<https://www.who.int/docs/default-source/documents/publications/classification-and-minimum-standards-for-foreign-medical-teams-in-sudden-onset-disasters.pdf>

[accessed 12 November 2020]

Royal College of Surgeons of England, *Ethical Principles of Working Overseas: A Guide to Good Practice for Surgeons and Surgical Teams*, London, 2019.

<https://www.rcseng.ac.uk/standards-and-research/standards-and-guidance/good-practice-guides/working-overseas/>

[accessed 12 November 2020]

Sathyanarayana Rao T.S., Radhakrishnan R., Andrade C., 'Standard operating procedures for clinical practice', Vol. 53(1):1-3, *Indian Journal of Psychiatry*, Wolters Kluwer - Medknow Publications, 2011.

<https://www.ncbi.nlm.nih.gov/pmc/articles/PMC3056180/>

[accessed 12 November 2020]

Sokhin A., 'Unified Principles, Requirements and Standards of Armed Forces Medical Support', *The Impact of NATO/Multinational Military Missions on Health Care Management*, North Atlantic Treaty Organization, Research and Technology Organization, 2001.

World Health Organization, *WHO Surgical Safety Checklist*, Geneva, 2009.

<http://www.who.int/patientsafety/safesurgery/checklist/en/>

[accessed 12 November 2020]

WHO Emergency Medical Teams.

<https://www.who.int/news-room/q-a-detail/emergency-medical-teams>

[accessed 12 November 2020]

World Medical Association, *WMA International Code of Medical Ethics*, London 1949, amended Pilanesburg, 2006.

<https://www.wma.net/policies-post/wma-international-code-of-medical-ethics/>

[accessed 12 November 2020]

Channels for complaint – the ombudsman

References:

The European Union Ombudsman.
<https://www.ombudsman.europa.eu/en/home>
[accessed 14 November 2020]

The UN Ombudsman and Mediation Services.
<https://www.un.org/en/ombudsman/>
[accessed 14 November 2020]

Trusting behaviours

Reference:

Covey, S., *The Speed of Trust*, Simon & Schuster, New York, 2006.

Managing communication and media relations

Authored by:

Christian Lindmeier, World Health Organization, Geneva, Switzerland

Respecting the environment

Authored by:

Emilia Wahlstrom, UNEP/OCHA Joint Environment Unit, Geneva, Switzerland

References:

‘Reducing environmental impact in humanitarian response’, *Sphere Thematic Sheets Series 2019*, The Sphere Project, Geneva.
<https://spherestandards.org/wp-content/uploads/Sphere-thematic-sheet-environment-EN.pdf>
[accessed 13 November 2020]

Sustainability in the UN System, ‘Greening the Blue’.
<http://www.greeningtheblue.org/index.html>
[accessed 13 November 2020]

Chapter 7

Reference:

Lloyd Roberts, David, *Staying Alive: Safety and security guidelines for humanitarian volunteers in conflict areas*, International Committee of the Red Cross, Geneva, 1999 (updated 2005).

https://www.icrc.org/en/doc/assets/files/other/icrc_002_0717.pdf

Communications equipment

Updated by:

Marcus Lammering, German Federal Agency for Technical Relief (THW), Bonn, Germany

References:

Templfi K. et al. (ed.), *Principles of Remote Sensing: An introductory textbook*, The International Institute for Geo-Information Science and Earth Observation, Enschede, 2009.

https://www.itc.nl/library/papers_2009/general/principlesremotesensing.pdf

[accessed 13 November 2020]

UCI Office of Information Technology, *UCI Radio Use and Procedures*, University of California, Irvine.

https://www.oit.uci.edu/wp-content/uploads/Radio_Use_Procedures.pdf

[accessed 13 November 2020]

Map reading and navigation

Credit:

Geoscience Australia, *Map Reading guide: How to Use Topographic Maps, Edition 4*, Canberra 2020.

© Commonwealth of Australia (Geoscience Australia), 2020.

This product is released under the Creative Commons Attribution 4.0 International Licence.

<http://creativecommons.org/licenses/by/4.0/legalcode>

<https://ecat.ga.gov.au/geonetwork/srv/eng/catalog>.

[search?node=svr#/metadata/102240](#)

[accessed 13 November 2020]

Huisman O. and de By R. (eds.), *Principles of Geographic Information Systems: An introductory textbook*, The International Institute for Geo-Information Science and Earth Observation, Enschede, 2009.

https://www.itc.nl/library/papers_2009/general/principlesgis.pdf

[accessed 13 November 2020]

Transport

Reference:

Emergency Management Australia, 'Four-Wheel-Drive Vehicle Operation, Manual 8', *Australian Emergency Manuals Series Part IV*, Canberra, 1997.

© Commonwealth of Australia, 1997.

<https://knowledge.aidr.org.au/media/1994/manual-37-four-wheel-drive-vehicle-operation.pdf>

[accessed 13 November 2020]

Chapter 8

Reference:

United Nations Office for the Coordination of Humanitarian Affairs (OCHA), *United Nations Disaster Assessment and Coordination, UNDAC Field Handbook, Seventh Edition*, 2018.

https://www.unocha.org/sites/unocha/files/1823826E_web_pages.pdf

[accessed 30 September 2020]

ICOON

Global picture
dictionary:
If you can't say it,
show it!

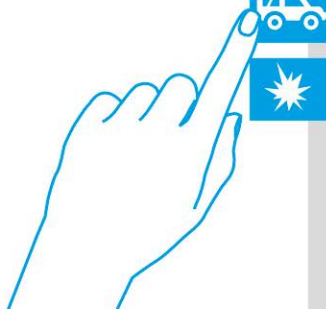

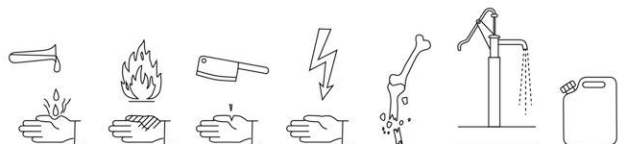
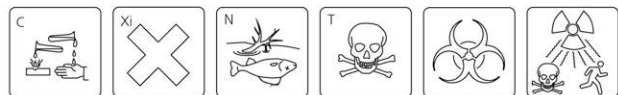
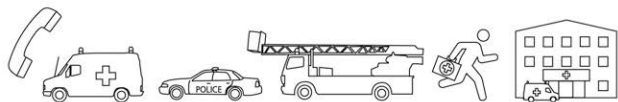
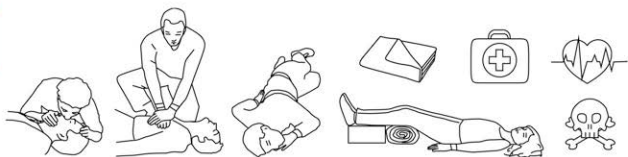

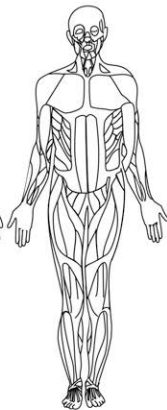
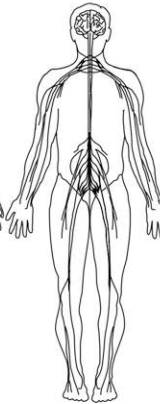
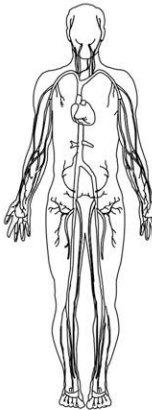
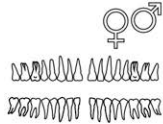
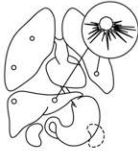
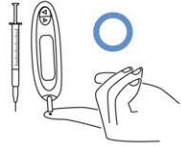
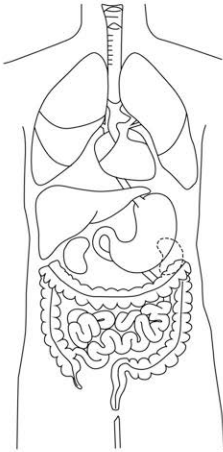

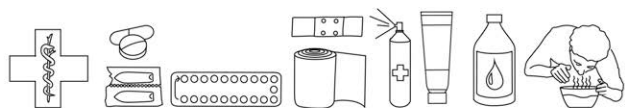
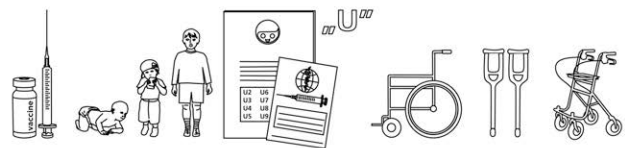
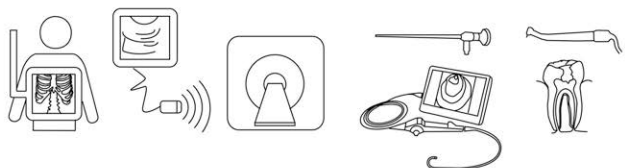
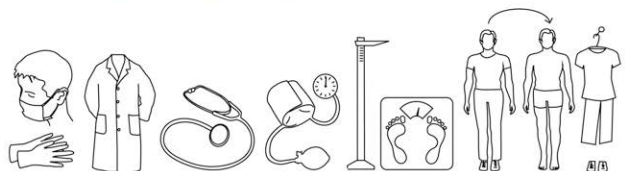
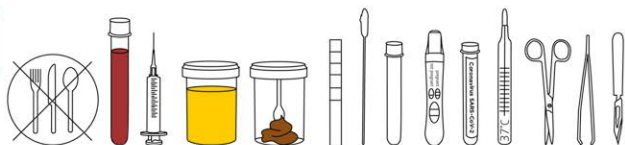

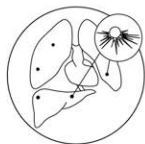
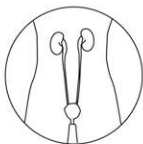
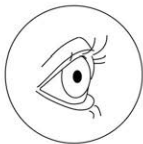
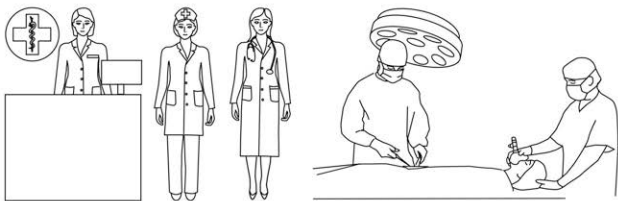

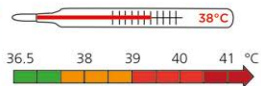

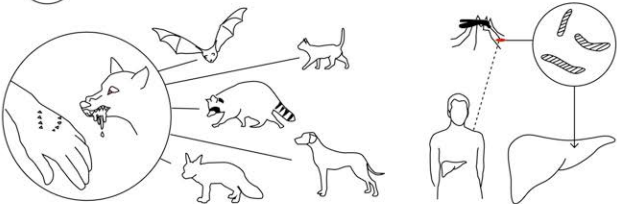
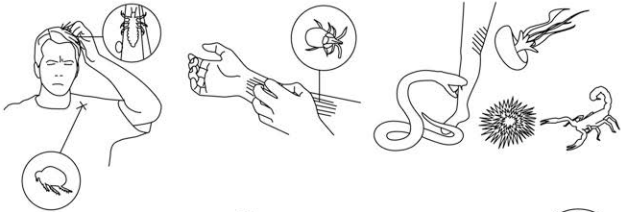
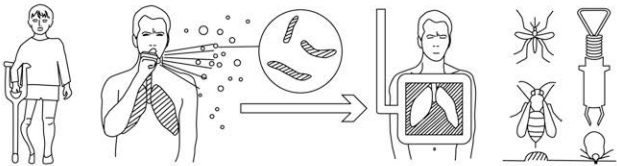
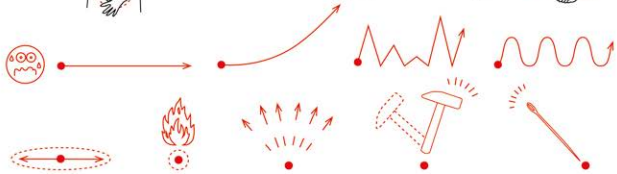

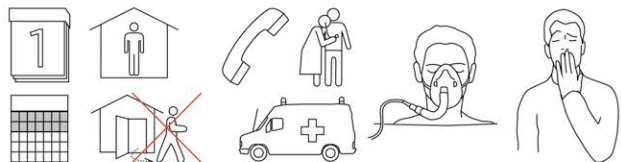
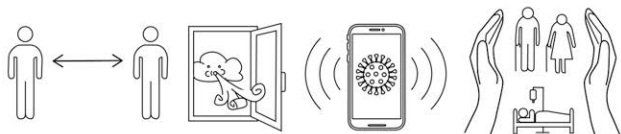
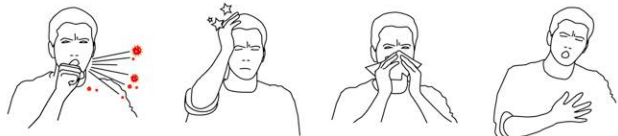
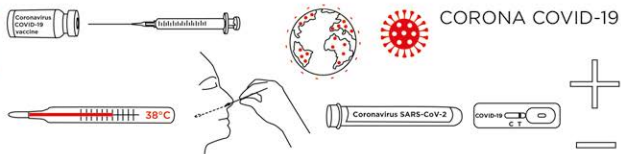

EBOLA

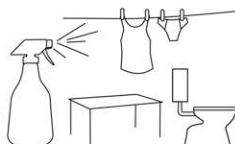
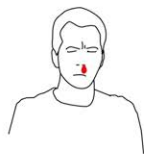
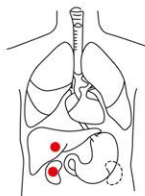
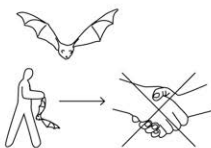
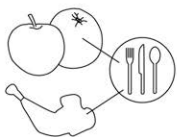

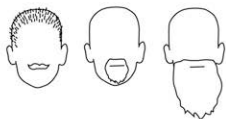
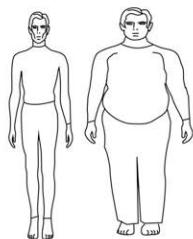
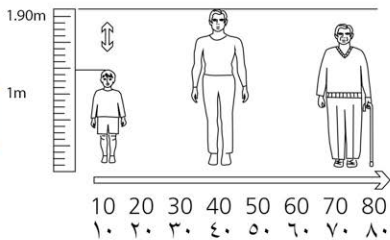

50 60 70

5. 6. 7.

80 100 120

8. 10. 12.



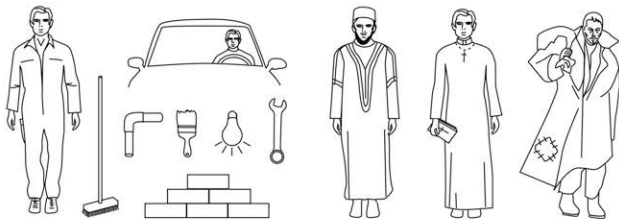
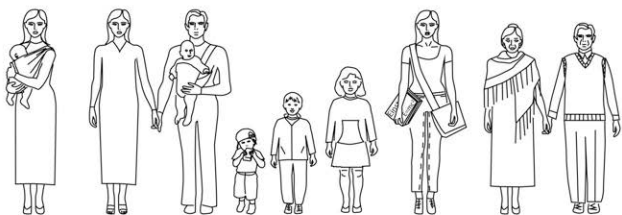

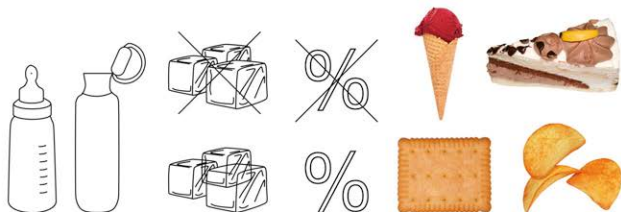
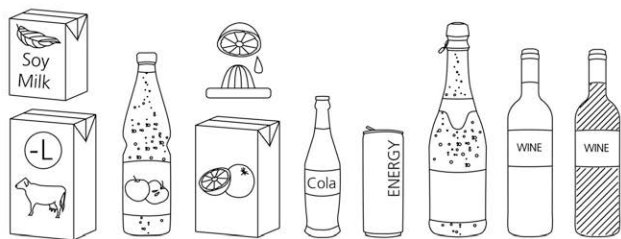
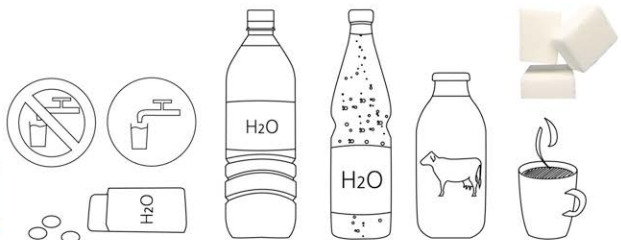

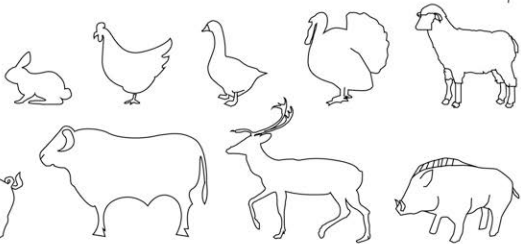
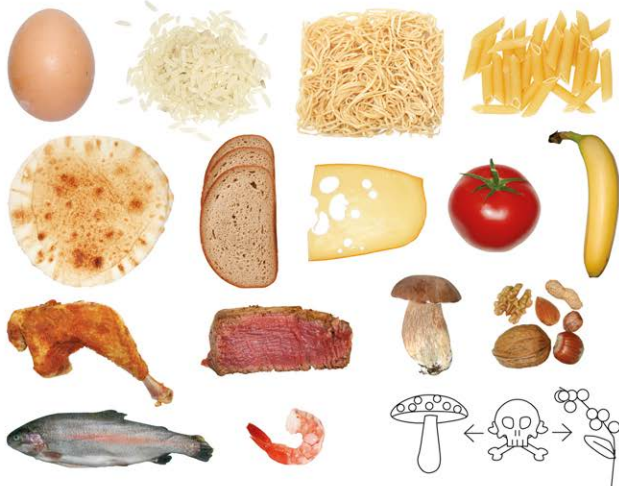

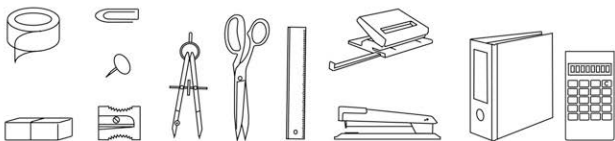
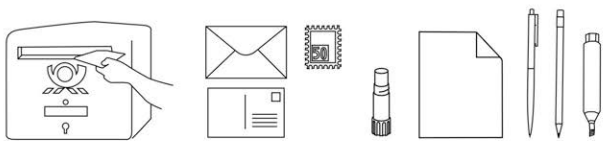
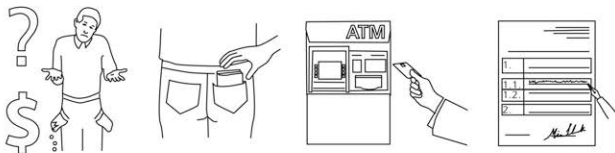
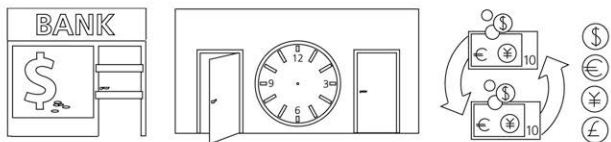

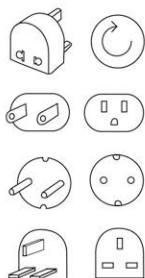

CD
DVD
HD DVD

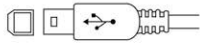
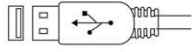
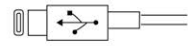
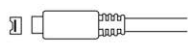
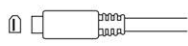
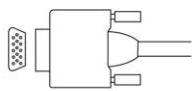
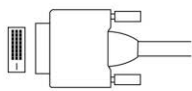
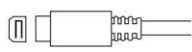
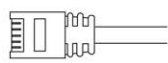
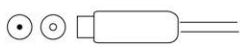
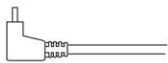
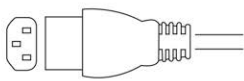
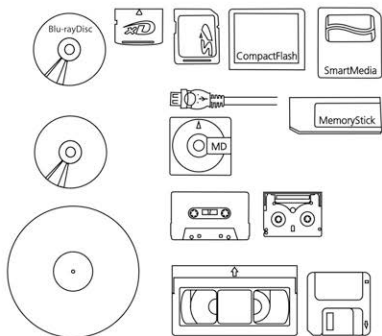
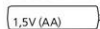
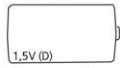
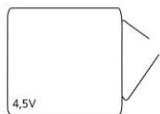

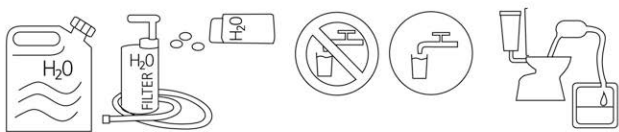
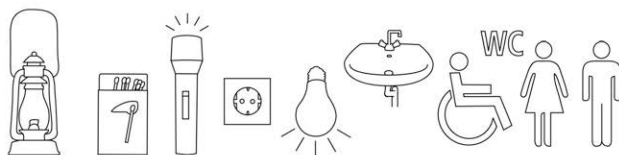
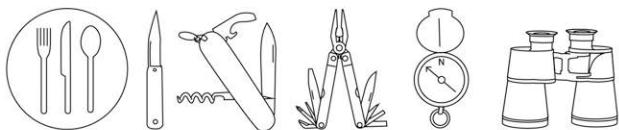
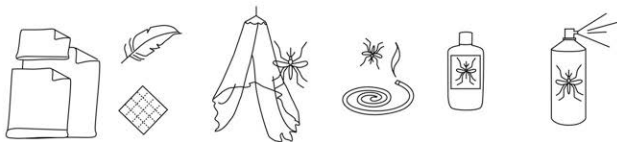

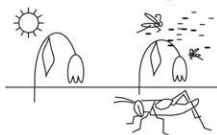
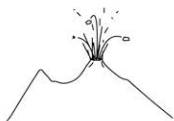
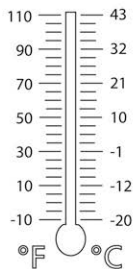
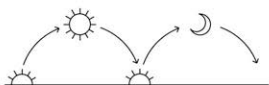

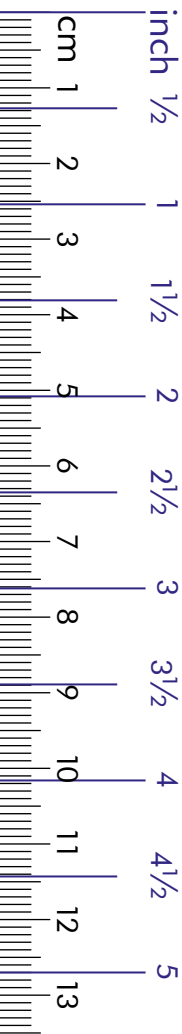

30 km/h 19 mph

70 km/h 43 mph

120 km/h 74 mph

30 mph 48 km/h

70 mph 113 km/h

120 mph 193 km/h



1m² 10.76 sq ft

1 sq ft 0.1 m²

1ha 2.5 acre

1acre 0.4 ha

1km² 0.4 sq mi

1sq mi 2.6 km²



1ml 0.03 fl oz

1fl oz 28 ml

1liter 0.26 gallon

1gallon 3.8 liter

1 cuft 0.028 m²

1 m² 35.3 cuft



1cm 0.4 inch

1inch 2.54 cm

1m 3.3 ft

1ft 0.3 m

1km 0.6 mile

1mile 1.6 km



1g 0.03 oz

1oz 28.35 g

1kg 2.2 lbs

1lbs 0.45 kg



1 tn.l. (UK) 1.016 t

1 tn.sh.(us) 0.907 t

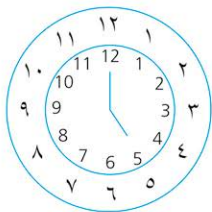

€ \$ US\$ ¢ £ ¥ kr CNY sFr

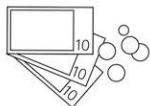

R RUR NIS $\frac{1}{2}$ $\frac{1}{4}$ $\frac{3}{4}$ ‰ %
kJ Watt Volt kWh PS db

1 2 3 4 5 6 7 8 9 10

י יב יג יד טו טז יז יח יט יא

0 10 100 1,000 10,000 100,000 1,000,000 10,000,000

1 2 3 4 5 6 7 8 9 10 11 12 13 14 15 16 17 18 19 20

21 22 23 24 25 26 27 28 29 30 31 32 33 34 35 36 37 38

39 40 41 42 43 44 45 46 47 48 49 50 51 52 53 54 55 56

57 58 59 60 61 62 63 64 65 66 67 68 69 70 71 72 73 74

75 76 77 78 79 80 81 82 83 84 85 86 87 88 89 90 91 92

93 94 95 96 97 98 99 100





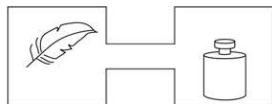
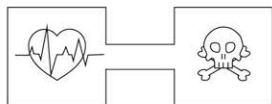
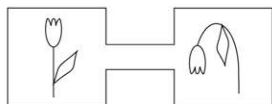
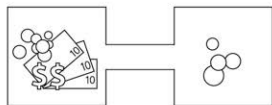
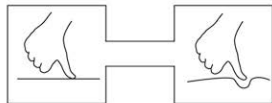
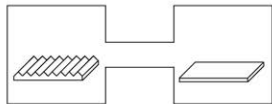
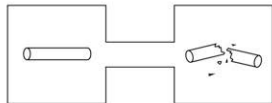
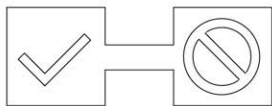
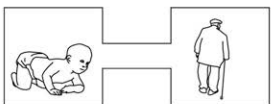
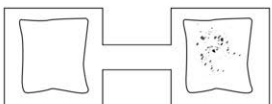
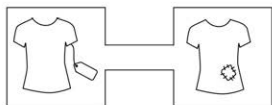
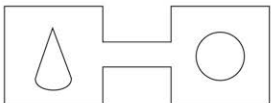
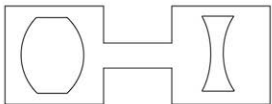
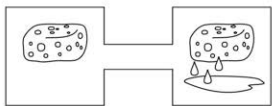

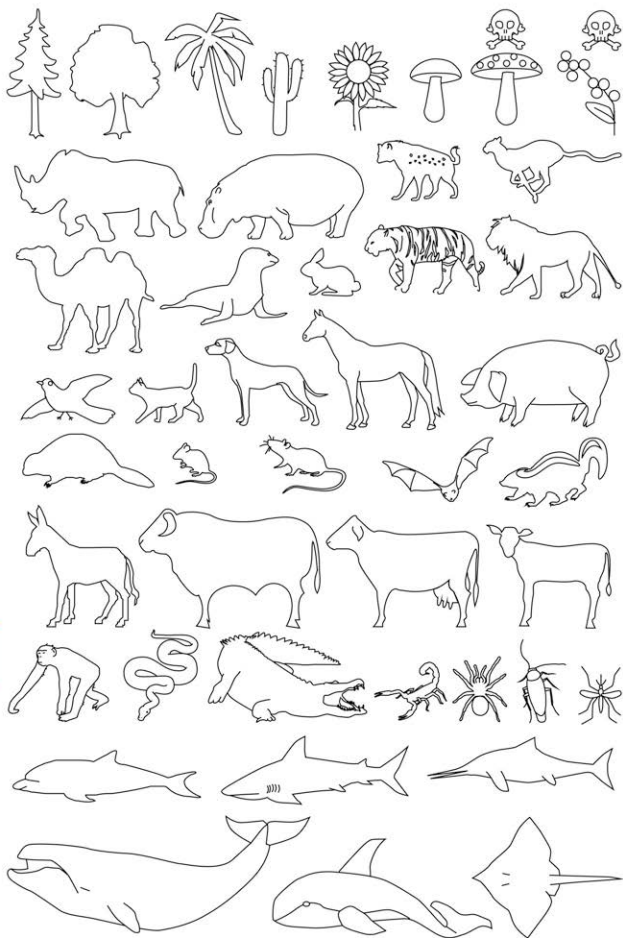

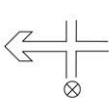
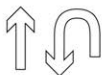
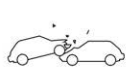
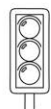
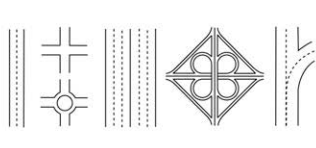
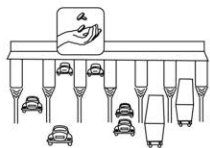
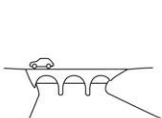
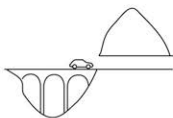
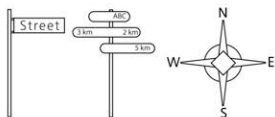
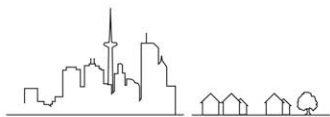

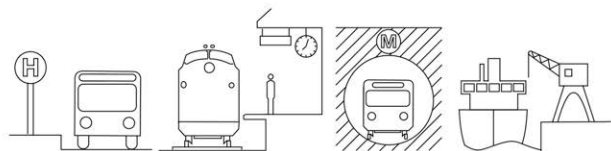
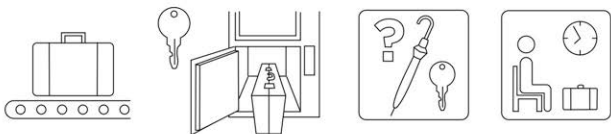
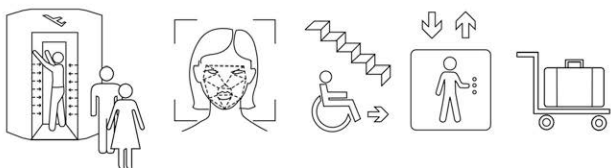
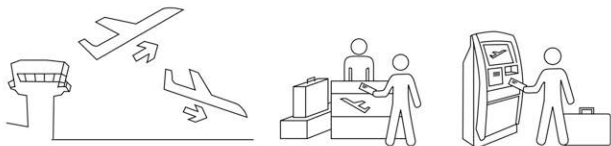

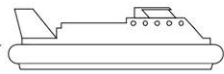
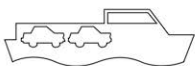
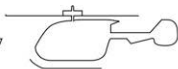
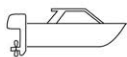
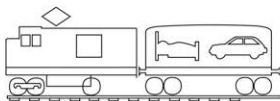
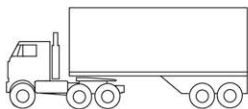
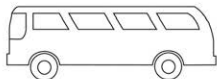
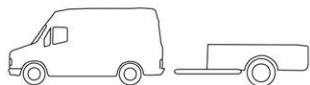
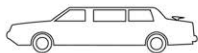

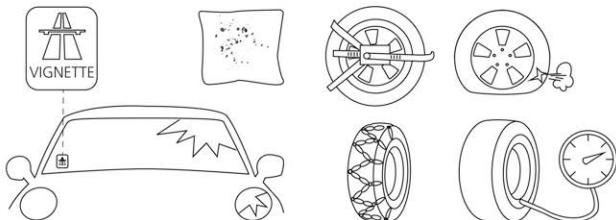
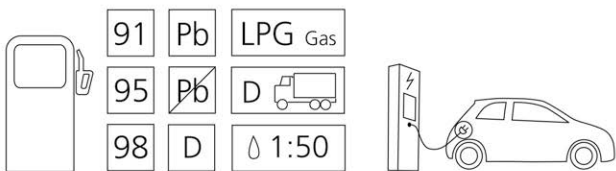
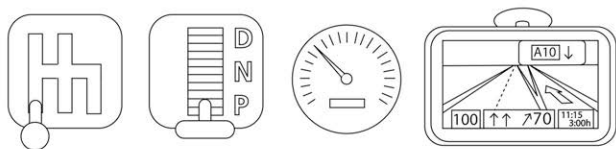
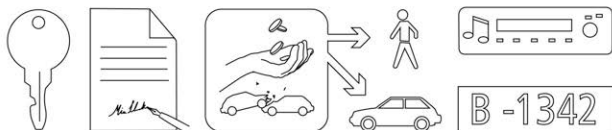

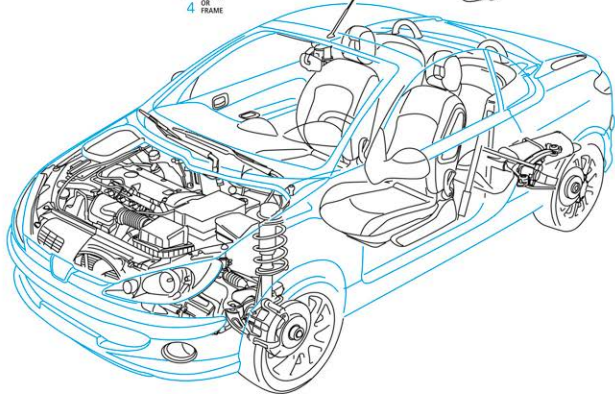
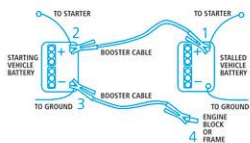
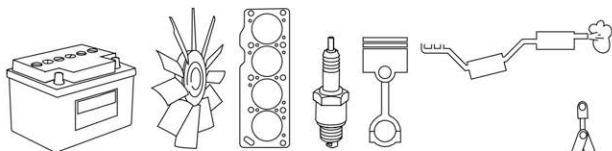
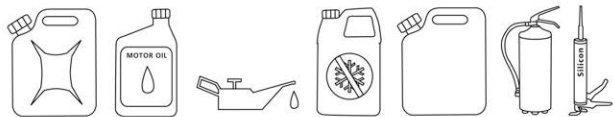

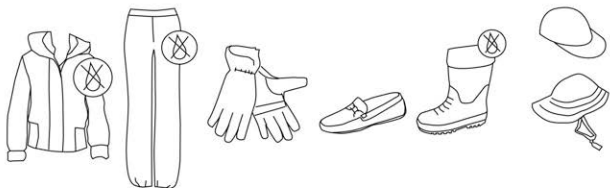
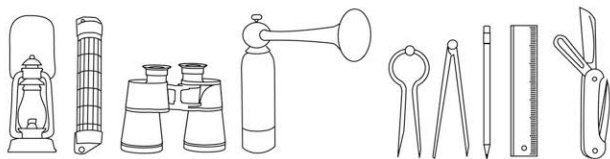
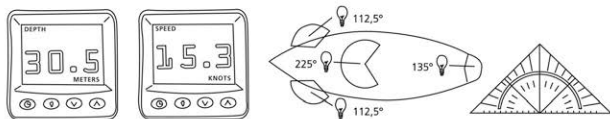
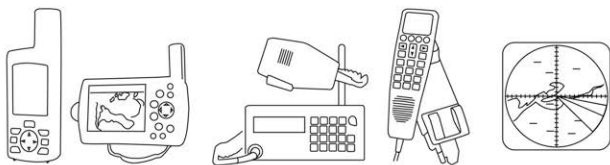
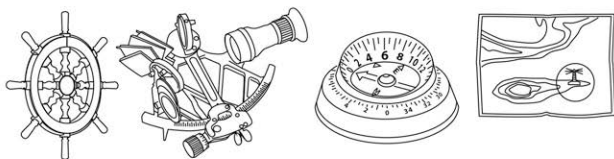

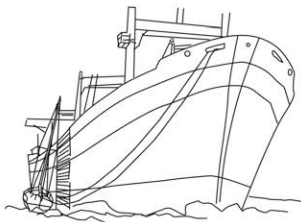
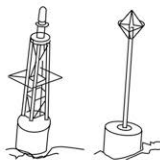
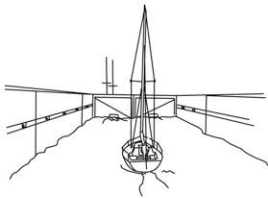
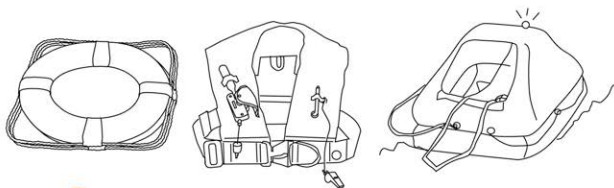

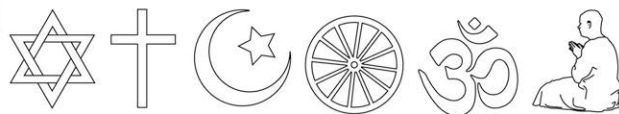
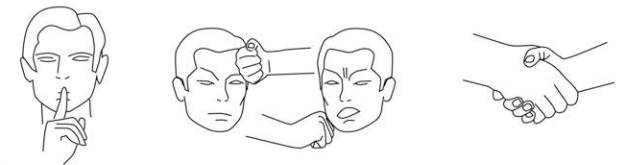
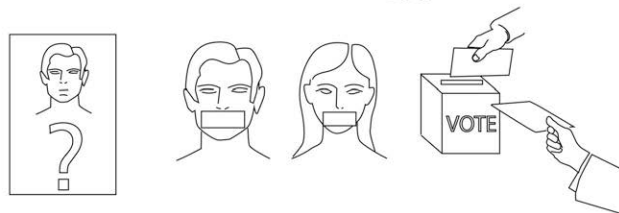
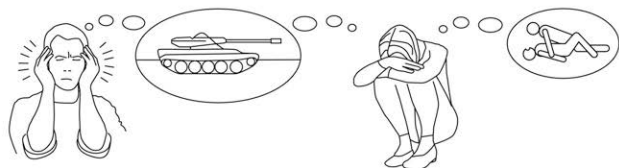
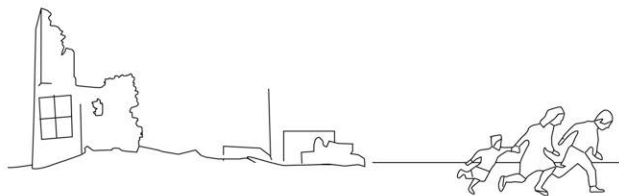

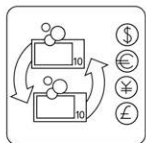
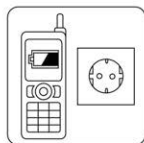
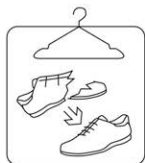
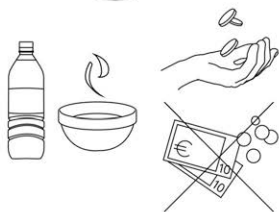
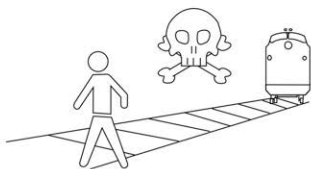
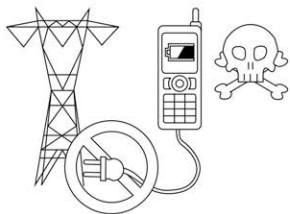
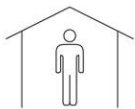

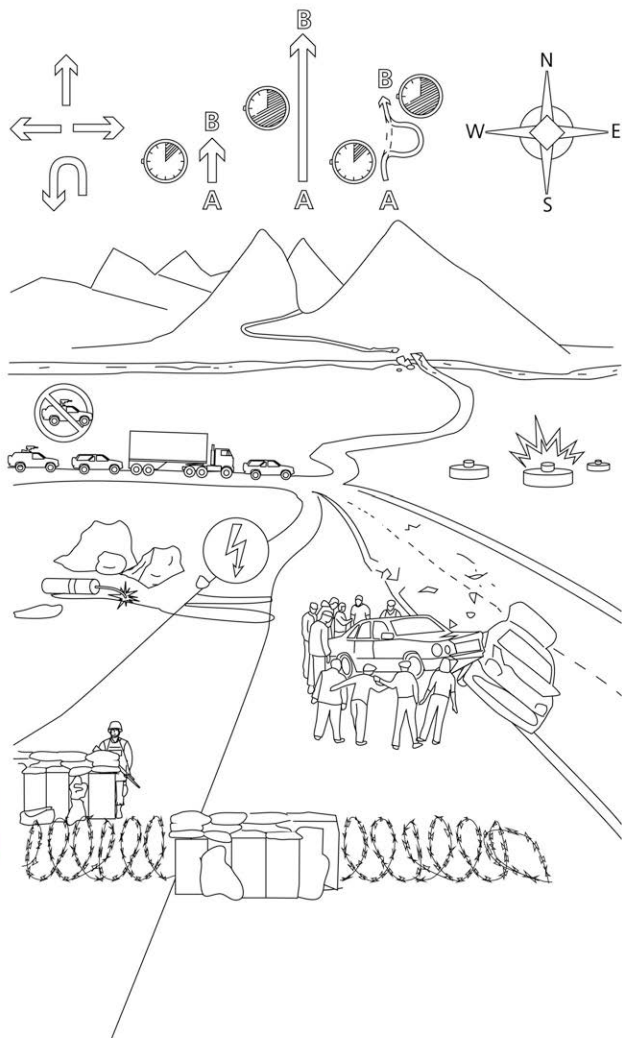

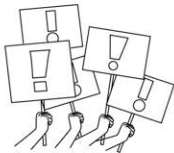
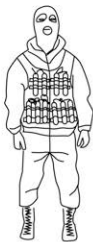
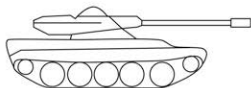
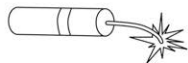

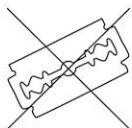
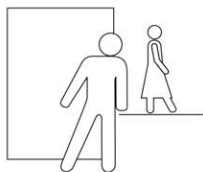
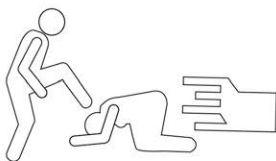

www.incontrol-handbook.org