



Health Care Waste Management **MANUAL**

Fourth Edition



**HEALTH CARE WASTE
MANAGEMENT MANUAL
FOURTH EDITION
2020**

DEPARTMENT OF HEALTH
HEALTH FACILITY DEVELOPMENT BUREAU

Health Care Waste Management Manual
Fourth Edition
2020

The preparation and publication of this document was made possible through the Technical Assistance of the World Health Organization (WHO), “Updating the Manual on Health Care Waste Management” funded through the Australian Department of Foreign Affairs and Trade (DFAT).

This document is published by the Department of Health (DOH) – Health Facility Development Bureau (HFDB) with office at Building 4, San Lazaro Compound, Tayuman St. cor. Rizal Ave., Sta. Cruz, Manila, Philippines 1003, for general distribution.

All rights reserved. Subject to the acknowledgement of DOH-HFDB, the Manual may be freely abstracted, reproduced or translated in part or in whole for non-commercial purposes only. If the entire work or substantial portions will be translated or reproduced, permission should be requested from the DOH-HFDB.



Republic of the Philippines
Department of Health
OFFICE OF THE SECRETARY



MESSAGE

“Health is everybody’s business. Health systems only work when everyone works together to ensure that no one is left behind.”

Universal Health Care (UHC) is both a vision and a commitment, so that all Filipinos are provided with the full range of high-quality health services — from preventive to promotive, curative, rehabilitative, and palliative — without the financial risks.

The signing of the UHC Act is an achievement that ushers a new chapter in the reform of the Philippine health system. The Act operationalizes primary health care and mainstreams health promotion to protect people from disease, empowers individuals and communities to maintain good health, and supports effective management of illness and disability. UHC will shift the health system approach towards a more balanced approach emphasizing prevention and health promotion.

Among the significant reforms that will be implemented over time include automatic enrollment of all Filipinos to the National Health Insurance Program; designating PhilHealth as the national purchaser for health goods and services for individuals including medicines; improvement of health facilities especially in underserved areas; responding to the gap in health workers throughout the country; strategic engagement of the private sector; and creating and expanding new functions in the Department of Health to improve the delivery of health services.

Under the premise of these new reforms, guidelines for environmental health must also leverage on strong health promotion and prevention strategies. In keeping with this goal, the Health Care Waste Management Manual was revisited, updated, and fortified with information that will be accessible and useful to different types of health care facilities in the country – hospitals, clinics that offer specialized health services, rural health units and barangay health stations that deliver primary care in the communities.

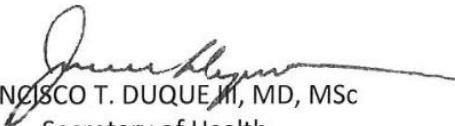
FRANCISCO T. DUQUE III, MD, MSc
Secretary of Health

ACKNOWLEDGEMENT

This Fourth Edition of the Health Care Waste Management Manual was made possible through the collaborative effort of the various stakeholders and resource persons whose names appear in the succeeding pages and whom we thank for actively participating in the consultative meetings and for sharing their experience and knowledge:

Department of Health

Ms. Madeliene Gabrielle Doromal	Health Facility Development Bureau
Ar. Jean Paolo Policarpo	Health Facility Development Bureau
Ms. Teresita Cruz	Health Facility Development Bureau
Engr. Rodelio Pineda	Health Facilities and Services Regulatory Bureau
Engr. Severino Reyes III	Health Facilities Enhancement Program
Engr. Maria Sonabel Anarna	Disease Prevention and Control Bureau
Engr. Gerardo Mogol	Disease Prevention and Control Bureau
Engr. Luis Cruz	Disease Prevention and Control Bureau
Dr. Valeriano Timbang, Jr.	Disease Prevention and Control Bureau
Ms. Maria Victoria Madura	Health Promotion and Communication Service
Mr. Brian Aviguetero	Health Promotion and Communication Service
Mr. Julius Solano	Center for Health Development – CAR
Ms. Jamborette Pangsiw	Center for Health Development – CAR
Ms. Arrami Mayon	Center for Health Development – CARAGA
Mr. Adrian Doctolero	Center for Health Development – Ilocos
Mr. Ashlrey Antonio	Center for Health Development – Region I
Mr. Nikky Bryan Taguibao	Center for Health Development – Region II

Department of Environment and Natural Resources

Engr. Leonie Ruiz	EMB Hazardous Waste Management Section
Engr. Santini Quiocson	EMB Hazardous Waste Management Section
Mr. Julito Tangalin	EMB Hazardous Waste Management Section
Mr. Irvin Cadavona	EMB Hazardous Waste Management Section

Department of Science and Technology

Ms. Cynthia Borromeo	Industrial Technology Development Institute
Ms. Clarissa Reyes	Philippine Council for Health Research and Development
Ms. Ervinna Cruz	Philippine Council for Health Research and Development

Local Government Units

Mr. Wilfredo Leyva	Antipolo City Health Office
Mr. Michael Mang-usan	Baguio City Health Services Office
Dr. Eduardo Posadas	La Union Provincial Health Office
Mr. Reymark Tasico	Malvar Rural Health Unit
Mr. Alfhie Manto	Malvar Rural Health Unit
Mr. Romeo Halcon	Manila Health Department
Engr. Mitzie Salvador	Manila Health Department
Ms. Riah Fojas	San Pedro Rural Health Unit
Mr. Reynante Arboleda	San Pedro Rural Health Unit
Ms. Camille Canubar	Santo Tomas, Batangas Rural Health Unit
Mr. Pedrito Mayuga	Santo Tomas, Batangas Rural Health Unit

Hospitals

Dr. Roberto A. Espos, Jr.	De La Salle Medical Center Cavite
Ms. Riza Bautista-Lumagui	De La Salle Medical Center Cavite
Engr. Lowell Lee	De La Salle Medical Center Cavite
Ms. Amelani A. Banca	De La Salle Medical Center Cavite
Ms. Carmi Anahaw	De La Salle Medical Center Cavite
Ms. Michelle Saulog	De La Salle Medical Center Cavite
Ms. Paola Katrina Ching	De La Salle Medical Center Cavite
Mr. Mark Louie A. Ona	Dr. Jose N. Rodriguez Memorial Hospital
Mr. Aries M. Esma	Manila Doctors Hospital
Dr. Ma. Lourdes Otayza	Manila Doctors Hospital
	Mariano Marcos Memorial Hospital and Medical Center
Dr. Ma. Paz Otayza	Mariano Marcos Memorial Hospital and Medical Center
	Mariano Marcos Memorial Hospital and Medical Center
Engr. Jose Barsaga	Philippine Heart Center
Engr. Jennifer Quintero	Rizal Medical Center
Ms. Gilda Cirila A. Ramos	San Juan de Dios Hospital
Ms. Ma. Melody S. Licuanan	San Lazaro Hospital
Engr. Aida Calma	San Lazaro Hospital
Ms. Jonalyn T. Lacsamana	San Pedro Jose L. Amante Emergency Hospital
Mr. Jose B. Barsaga	Philippine Heart Center
Mr. Primitivo Jose C. Reyes III	The Medical City
Mr. Jonathan M. Ambrocio	The Medical City
Ms. Cristy Donato	The Medical City

Medical Association, Regulators, NGO, Academe

Ms. Gina Noble	Philippine Association of Medical Technologists, Inc.
Dr. Elma Leones Javier	Philippine Dental Association
Mr. Emerson Lesly D. Cruz	Philippine Health Insurance Corporation
Mr. Climaco E. Caliwara	Philippine Hospital Association
Mr. Rogelio V. Dazo, Jr.	Philippine Medical Association
Ms. Moresa T. Reyes	Health Care Without Harm – Asia
Mr. Alex Mendoza	National University

World Health Organization

Engr. Bonifacio Magtibay	World Health Organization – Philippines
Mr. Eduardo Genciagan, Jr.	World Health Organization – Philippines
Ms. Christine Gaylan	World Health Organization – Philippines
Engr. Jose Marie U. Lim	APW Contractor/LCI Envi Corporation
Ms. Rebecca L. Husayan	APW Contractor/LCI Envi Corporation
Engr. Patricia Ann C. Go	APW Contractor/LCI Envi Corporation
Ms. Krisha L. Santos	APW Contractor/LCI Envi Corporation

TABLE OF CONTENTS

MESSAGE	i
ACKNOWLEDGEMENT	i
TABLE OF CONTENTS	iii
LIST OF TABLES	vii
LIST OF FIGURES	vii
LIST OF BOXES	viii
LIST OF ABBREVIATIONS	ix
PART I—GENERAL CONSIDERATIONS AND OVERVIEW	1
1 Introduction	2
1.1 Background	2
1.2 Purpose and Intent	2
1.3 Scope and Limitations	2
1.4 Contents of the Manual	3
1.5 Approach	3
1.6 Key Concepts.....	4
1.7 Expected Outcomes.....	6
2 Health Care Waste Source, Categorization, and Characterization	7
2.1 General Definition of HCW	7
2.2 Categorization of HCW.....	7
2.3 Generation of HCW	15
2.4 Waste Assessment Approaches	20
3 Risks Associated with Health Care Waste	23
3.1 Persons at Risk.....	23
3.2 Types of Hazard and Mode of Transmission	23
3.3 Additional Considerations and Emerging Threats of HCW to Public Health and the Environment	29

3.4	Risk Assessment Approach to HCWM.....	33
4	Legislative, Regulatory, and Policy Aspects of Health Care Waste	37
4.1	Guiding Principles	37
4.2	International Agreements/Conventions.....	38
4.3	National Policies and Related Issuances	39
4.4	Other Relevant Issuances and Guidelines.....	44
	PART II—HEALTH CARE WASTE MANAGEMENT SYSTEM	47
5	Health Care Waste Management Planning	48
5.1	Organization and Functions	49
5.2	Health Care Waste Management Committee.....	50
5.3	Health Care Waste Management Plan	51
6	Health Care Waste Minimization	57
6.1	Principles.....	59
6.2	Benefits of Waste Minimization	60
6.3	Waste Minimization Techniques	61
6.4	Administrative Control Measures	68
7	Health Care Waste Segregation, Collection, Storage, and Transport.....	70
7.1	Principles.....	70
7.2	HCW Segregation.....	71
7.3	Collection and Transport within the HCF	79
7.4	On-site Storage of HCW.....	82
7.5	Off-site Collection	88
7.6	Off-site Transport.....	89
8	Health Care Waste Treatment and Disposal	90
8.1	Selection of Treatment Methods	90
8.2	Basic Treatment Processes.....	91
8.3	Treatment Technologies.....	94
8.4	On-site HCW Treatment Facilities.....	103

8.5	HCW Disposal	104
9	Managing Wastewater Generated by Health Care Facilities	114
9.1	Composition of HCF Wastewater	114
9.2	Sources and Characteristics of HCF Wastewater	115
9.3	Collection of HCF Wastewater	115
9.4	Treatment of HCF Wastewater	116
	PART III—ADMINISTRATIVE CONTROLS AND REQUIREMENT	124
10	Administrative Requirements	125
10.1	Oversight and Management at the National and Local Levels	125
10.2	Administrative Requirements at the Facility Level	126
10.3	Budgetary Requirements to Implement the HCWM Program	128
10.4	Options for Financing	132
11	Health and Safety Practices	134
11.1	Principles	134
11.2	Occupational Health Risks	135
11.3	Exposure Prevention and Control	137
11.4	Hospital Hygiene and Infection Control	141
11.5	Occupational Health and Safety Program	146
11.6	Education, Communication, Training and Awareness	149
12	Health Care Waste Management in Emergencies	153
12.1	Emergency Management Plan	153
12.2	Contingency Planning and Emergency Preparedness	161
12.3	Emerging Issues	162
	PART IV—GLOSSARY, ANNEXES, AND REFERENCES	167
	Definition of Terms	168
	ANNEX A: Process Flow Diagrams	177
	ANNEX B: Requirements and Guides	194
	ANNEX C: Procedures	209
	ANNEX D: Sample Checklists and Forms	218

ANNEX E: Drawings and Illustrations.....	229
ANNEX F: Links.....	242
References.....	246

LIST OF TABLES

Table 1: Type of HCW typically generated by HCFs.....	16
Table 2: Potential infections caused by exposure to HCW	25
Table 3: Example of hazards identified in HCFs (under WASH)	33
Table 4: HCW bins and plastic liners specifications, color-coding, marking/labelling	77
Table 5: Applications of treatment and disposal methods for specific HCW categories	108
Table 6: Sources and characteristics of HCF wastewater	115
Table 7: Significant effluent parameters for HCFs	118
Table 8: Responsibilities of implementing and cooperating agencies for HCWM.....	125
Table 9: Hazards to health care workers	136
Table 10: Ways to improve infection control	145
Table 11: Key issues in rapid initial assessment	154
Table 12: Segregation of HCW in emergencies	156
Table 13: Summary of pharmaceutical disposal methods in and after emergencies	157
Table 14: HCWM practice in emergencies.....	158
Table 15: Key points relating to climate change	163
Table 16: Key points relating to environmental issues	164
Table 17: Key points relating to waste technology	165
Table 18: Key points relating to social, cultural, and regulatory changes	166

LIST OF FIGURES

Figure 1: Categories of health care waste	7
Figure 2: Comparison of estimated daily waste generation in two types of HCFs	19
Figure 3: Seven important points in waste management	48
Figure 4: Basic elements for safe HCWM in primary care facilities	56
Figure 5: HCW handling	57
Figure 6: Waste management hierarchy	58
Figure 7: Waste minimization techniques	61

LIST OF BOXES

Box 1: HCW covered in the classification of hazardous wastes under DAO 2013-22....	8
Box 2: Highly infectious diseases.....	9
Box 3: Categories of harmful cytotoxic drugs	10
Box 4: Examples of heavy metals found in HCW	13
Box 5: Non-hazardous chemical waste.....	13
Box 6: Volume of generated M501 and M503 as per EMB data	17
Box 7: Chain of infection	24
Box 8: Endocrine disruptors.....	30
Box 9: Antimicrobial resistance	32
Box 10: Microplastics	32
Box 11: Overview of WASH FIT.....	34
Box 12: Objectives of HCWM Planning.....	48
Box 13: Planning according to facility size	49
Box 14: HCWM Committee for hospitals.....	51
Box 15: Details to include in the HCWM Plan.....	54
Box 16: Examples of practices to encourage waste minimization.....	59
Box 17: Factors to consider in Green Procurement	62
Box 18: Life Cycle Analysis (LCA) Tool.....	63
Box 19: Examples of sterilization methods for re-usable items.....	65
Box 20: Recycling of plastics	66
Box 21: Composting techniques.....	67
Box 22: Environmental Management System.....	68
Box 23: Minimum requirement for HCW segregation: three-bin system	71
Box 24: Sharp containers	74
Box 25: Minimum requirements for HCW storage.....	88
Box 26: Minimum measures for HCW transport.....	89
Box 27: Selecting HCW treatment and disposal methods for primary care facilities ..	90
Box 28: Microbial inactivation.....	91
Box 29: General considerations in the use of autoclave	95
Box 30: Treatment of wastes from medical laboratories.....	95
Box 31: Small-scale incineration	101
Box 32: Construction of sharps pit/concrete vault	105
Box 33: Overview of treatment and disposal of HCW in primary care facilities	110
Box 34: Management of wastes from home care services.....	111
Box 35: Management of wastes from immunization campaign activities.....	112
Box 36: Minimum approach for management of liquid HCW	113
Box 37: Wastewater generation rate in HCFs	114
Box 38: Pre-treatment of HCF wastewater.....	117
Box 39: Septic tank systems operation and maintenance criteria.....	121
Box 40: Guide to basic wastewater system	123
Box 41: Required PPEs for health care workers.....	140
Box 42: Summary of PEP recommendations.....	147
Box 43: “My Five Moments of Hand Hygiene” in HCF	149
Box 44: Methods of communication and training	152
Box 45: Emergency contingency plan for HCW transporter	161

LIST OF ABBREVIATIONS

ABR	Anaerobic Baffled Reactor
ADB	Asian Development Bank
AMR	Antimicrobial Resistance
AO	Administrative Order
ASC	Ambulatory Surgical Clinic
APP	Annual Procurement Plan
BHDT	Bureau of Health Devices and Technology
BHFS	Bureau of Health Facilities and Services
BHS	Barangay Health Station
BSF	Blood Service Facility
CAT	Costing Analysis Tool
CD	Cleaning and Disinfection
CDC	Center for Disease Control and Prevention
CHD	Center for Health Development
COD	Chemical Oxygen Demand
CPR	Certificate of Product Registration
CSA	Central Storage Area
DBP	Development Bank of the Philippines
DENR	Department of Environment and Natural Resources
DILG	Department of Interior and Local Government
DOH	Department of Health
ECAT	Expanded Costing Analysis Tool
ECC	Environmental Compliance Certificate
EHS	Environmental Health Service
EIA	Environmental Impact Assessment
EIS	Environmental Impact Statement
EISCP	Environmental Infrastructure Support Credit Program
EMB	Environmental Management Bureau
EMS	Environmental Management System
EO	Executive Order
EOHO	Environmental and Occupational Health Office
FEFO	First to Expire, First Out
FIFO	First In, First Out
GPP	Green Procurement Policy
HCF/s	Health Care Facility/ies
HCW	Health Care Waste
HCWM	Health Care Waste Management
HEMS	Health Emergency Management Service
HFDB	Health Facility Development Bureau
HFSRB	Health Facilities and Services Regulatory Bureau
ICN	Infection Control Nurse
ICO	Infection Control Officer
ICU	Intensive Care Unit
IEC	Information, Education, and Communication
IEE	Initial Environmental Examination
IRR	Implementing Rules and Regulations
ISO	International Organization for Standardization

JAO	Joint Administrative Order
LCA	Life Cycle Analysis
LGU	Local Government Unit
LLDA	Laguna Lake Development Authority
LTO	License to Operate
MC	Memorandum Circular
MSDS	Material Safety Data Sheet
NCDPC	National Center for Disease Prevention and Control
NCHFD	National Center for Health Facility Development
NEC	National Epidemiology Center
NIH	National Institutes of Health
NPCC	National Pollution Control Commission
NRL	National Reference Laboratory
NSWMC	National Solid Waste Management Commission
NSRC	Newborn Screening Reference Center
OIC	Officer in Charge
OIR	Occupational Incident Report
OPD	Outpatient Department
OR	Operating Room
OSHA	Occupational Safety and Health Administration
PCO	Pollution Control Officer
PD	Presidential Decree
PDCA	Plan-Do-Check-Act
PHIC/PhilHealth	Philippine Health Insurance Corporation
PNRI	Philippine Nuclear Research Institute
POPs	Persistent Organic Pollutants
PPE	Personal Protective Equipment
RA	Republic Act
RBC	Rotating Biological Contractors
RHU	Rural Health Unit
SBR	Sequential Batch Reactor
SDG/s	Sustainable Development Goal/s
SLF	Sanitary Landfill Facility
STP	Sewage Treatment Plant
TSD	Treatment, Storage, and Disposal
UHC	Universal Health Care
UHU	Urban Health Unit
WASH	Water, Sanitation, and Hygiene
WASH FIT	Water and Sanitation for Health Facility Improvement Tool
WHA	World Health Assembly
WHO	World Health Organization
WMO	Waste Management Officer
WPRO	Western Pacific Regional Office
WWTP	Wastewater Treatment Plant



PART I – GENERAL CONSIDERATIONS AND OVERVIEW

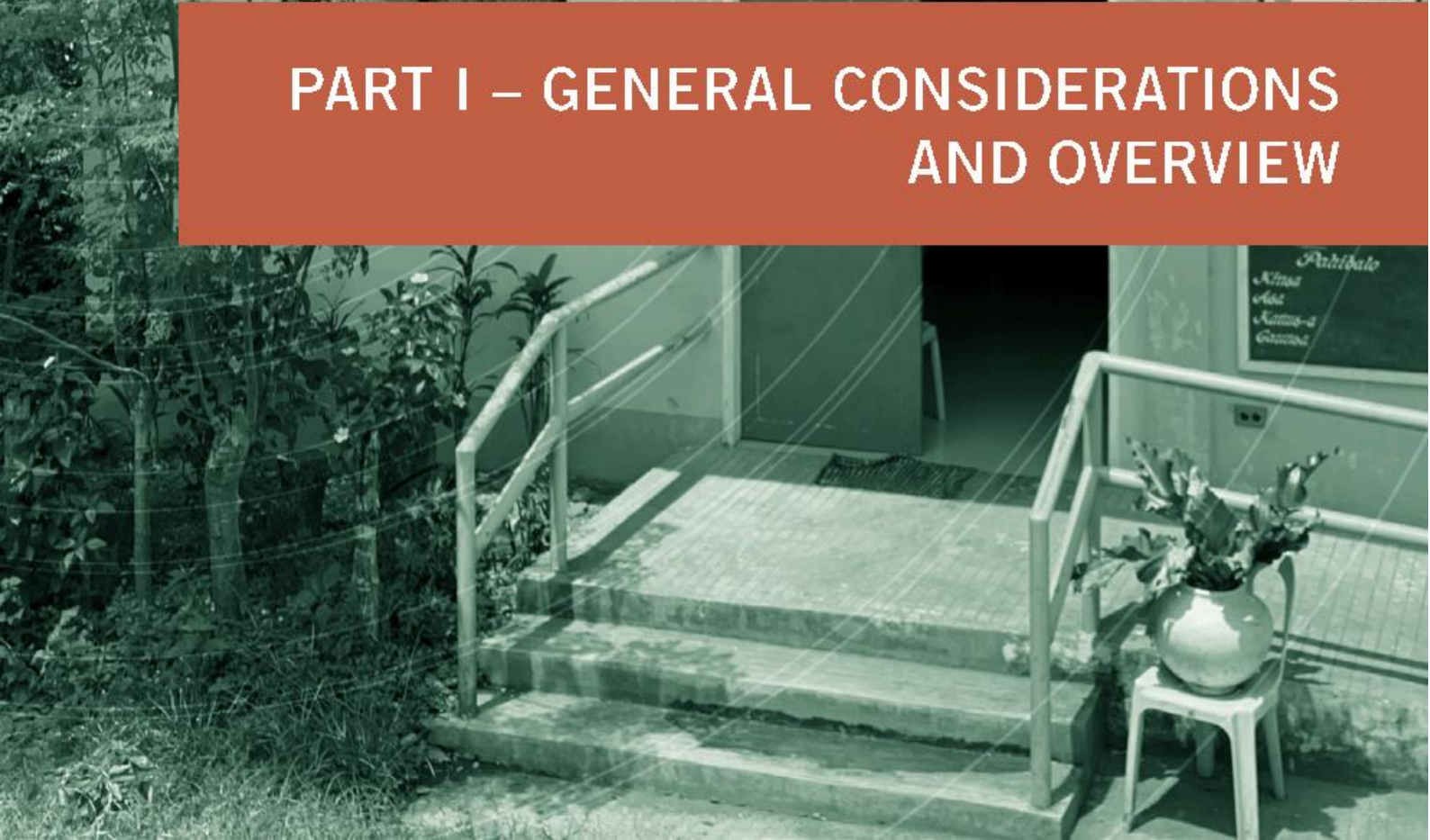

1 Introduction

1.1 Background

The First Edition of the “Hospital Waste Management Manual” was formulated and issued by the Department of Health (DOH) through the Environmental Health Service (EHS) in 1997.

In 2004, the DOH Environmental and Occupational Health Office (EOHO) issued the Second Edition, renamed “Health Care Waste Management Manual” and designed to provide guidance and practical information regarding safe, efficient, and environment-friendly waste management options not just for hospitals but for other health facilities in the country.

The DOH adopted a more participatory approach by collaborating with various stakeholders in reviewing, enhancing, and updating its policies and guidelines on health care waste management (HCWM). Published in 2011, the Third Edition is more user-friendly and substantiated with the new trends and universally accepted technologies.

Review and updating of the Manual is essential after five years or so to align with current initiatives and strategies and provide responsive information to all the stakeholders. Any proposal for revision should have been forwarded to the National Center for Health Facility Development for consideration and subject to the formal approval of the Secretary of Health.

1.2 Purpose and Intent

This document shall serve as the most comprehensive set of guidelines on the safe management of waste generated from health care activities in the country.

It incorporates the requirements of all Philippine laws and regulations governing HCWM and is designed for the use of individuals, public and private establishments, and other entities involved in segregation, collection, handling, storage, treatment, and disposal of waste generated from health care activities.

1.3 Scope and Limitations

This Manual covers all health care waste (HCW) as defined in **Chapter 2.1**. Waste generated by establishments that are not considered as health care facilities (HCFs) as defined in **Chapter 2.3** are not covered by this Manual and shall be governed by the existing environmental laws and policies of the different governing agencies other than the DOH.

1.4 Contents of the Manual

This Manual has four (4) major parts, each of which is subdivided into chapters:

PART I—GENERAL CONSIDERATIONS AND OVERVIEW includes this introduction to the Manual (Chapter 1); the general definition, typical sources, known categories, and current generation of HCW in the Philippine context (Chapter 2); expanded discussion on HCW risks and impacts to human health and the environment (Chapter 3); updated list and overview of the guiding principles, relevant international agreements, national policies, issuances, and guidelines (Chapter 4).

PART II—HEALTH CARE WASTE MANAGEMENT SYSTEM discusses the main components of the HCWM system, including HCWM planning (Chapter 5); concept of HCW minimization (Chapter 6); principles of proper HCW segregation, collection, storage, and transport (Chapter 7); some options for HCW treatment and disposal (Chapter 8); and guidelines on management of wastewater generated by HCFs (Chapter 9).

PART III—ADMINISTRATIVE CONTROLS AND REQUIREMENTS presents the administrative requirements to implement HCWM (Chapter 10); health and safety practices (Chapter 11); HCWM during emergencies, as well as emerging issues and trends in HCWM (Chapter 12).

PART IV—GLOSSARY, ANNEXES, AND REFERENCES provides an updated listing and definition of terms used in the Manual, the annexed supplementary materials (i.e., process flow diagrams, requirements and guides, procedures, sample checklists and forms, drawings and illustration, links to online resources), and the list of references.

1.5 Approach

The DOH recognizes its responsibility in setting up necessary policies, guidelines, and standards for safe management of HCW and its role in ensuring the compliance of all concerned on the effective and efficient handling of wastes, and in imposing discipline. To address the issues at hand, the following approaches will be undertaken:

- Clear definition of HCW, its various categories and the hazards/risks involved and acceptable methods of handling, collection, transport, treatment, storage, and final disposal, including waste minimization practices that generate the best results;
- Application of concepts that can minimize risks to human health and the environment, such as the chain of infection, the International Organization for Standardization (ISO) hierarchy of controls, and the waste management hierarchy;
- Implementation of appropriate review, monitoring, and evaluation system to ensure strict enforcement of the laws, policies, and guidelines on

HCWM;

- Streamlining national and local regulations on HCWM with international agreements and guidelines to achieve standardized HCWM approach for all types of HCFs;
- Inclusion of approved HCWM practices appropriate to the type, service capability, and subsequent waste generation of HCFs.
- Continuous review of the applicability of the laws, policies, and guidelines on HCWM vis-à-vis latest standards, trends, technologies; and
- Adopting measures that shall address issues on climate change, emerging pathogens, antimicrobial resistance, and social or cultural changes, which all have an impact on HCWM.

1.6 Key Concepts

The Fourth Edition Manual is a comprehensive compilation of the latest and most relevant instruments and processes designed for effective implementation of HCWM in all types of HCF whether in the urban or rural setting.

In order to realize its purpose, some health concepts, policies, and principles were adopted to serve as the groundwork for the Manual.

1.6.1 Sustainable Development Goals

The Sustainable Development Goals or SDGs are a collection of 17 global goals set by the United Nations General Assembly in 2015 for the year 2030. It is the blueprint to achieve better and sustainable future for all. It addresses several global challenges including access to safe and sustainable water, sanitation, hygiene, and environmental degradation. HCWM specifically addresses SDG No.3 on good health and well-being, SDG No. 6 on clean water and sanitation, and SDG No. 12 on responsible consumption and production.

1.6.2 Risk Management Concept

The concept of risk management in the HCF setting is best defined as the overall approach to identify, assess, and reduce the exposure to hazards of the patients, visitors and health care workers, the hazards being specific to HCW in this aspect. Risks are the likelihood of the identified hazards to cause harm in exposed population and the severity of the exposure. In order to prevent the hazard from affecting the population, a risk assessment is done using available information and data to predict how often it is likely to occur and the magnitude of the consequence. This risk management concept is an important tool of an HCF as it strives to integrate policies on HCWM Program within its day to day operations. This concept is elaborated in **Chapter 3 (Risks Associated with Health Care Waste)**.

Water and Sanitation for Health Facility Improvement Tool (WASH FIT)

WASH FIT is a multistep, iterative process to facilitate improvements in WASH services, quality, and experience of care in all types of HCFs. Among its purpose is to identify areas for quality improvement in facilities, including strengthening WASH and infection prevention and control policies and standards that will lead to lower infection rates, better health outcomes for patients and improved staff safety and morale. WASH FIT covers four broad areas: water, sanitation (including HCWM), hygiene (hand hygiene and environmental cleaning), and management. WASH services strengthen the resilience of health care systems to prevent disease outbreaks, allow effective responses to emergencies (including natural disasters and outbreaks) and bring emergencies under control when they occur. This concept is elaborated in **Chapter 4 (Legislative, Regulatory, and Policy Aspects of Health Care Waste)**.

1.6.3 Chain of Infection

The Chain of Infection is a model used to understand the infection process. It is illustrated by a circle of links, each representing a component in the cycle. Each link must be present and in sequential order for an infection to occur. The links are infectious agent, reservoir, portal of exit from the reservoir, mode of transmission, and portal of entry into a susceptible host. Understanding the characteristics of each link and the means by which the chain of infection can be interrupted provides the HCF workers with methods for supporting vulnerable patients, preventing the spread of infection and self-protection. Breaking any link in the chain will prevent infection, although control measures are most often directed at the “mode of transmission.” This concept is further discussed in **Chapter 3 (Risks Associated with Health Care Waste)**.

1.6.4 Hierarchy of Controls

Controlling exposures to occupational hazards is the fundamental method of protecting workers. Hierarchy of controls has been used as a means of determining feasible and effective controls in the workplace. The methods of control are defined in five groups as elimination, substitution, engineering and administrative controls and personal protective equipment. This concept is detailed in **Chapter 11 (Health and Safety Practices)**.

1.6.5 The Waste Management Hierarchy

A concept in waste management in which it is most preferable to prevent the generation of waste at source and reduce the quantity generated by adopting different methods of safe re-use, recycling, and recovery. Proper treatment and residuals disposal are the end-of-pipe approach. In addressing HCWM, waste minimization utilizes the first two elements that could help reduce the bulk of HCW for disposal; hence, the most “desirable” management practice aims to address the problem at source rather than “end-of-pipe.” ‘Desirability’ is defined in terms of the overall benefit of each method from their specific impacts on the environment,

protection of public health, financial affordability, and social acceptability. This is elaborated in **Chapter 6 (Health Care Waste Minimization)**.

1.7 Expected Outcomes

Under the "duty of care" principle (elaborated in **Chapter 4.1**), every HCF has the ethical responsibility of ensuring that there are no adverse health effects and environmental consequences resulting from the handling, collection, storage, treatment, and disposal of HCW it generates. Users of this Manual will be guided in implementing safe and environmentally sound management of HCW in any HCF. Proper and strict compliance with the set standards will result to benefits such as:

- Protection of human health and safety by controlling and/or reducing exposure of persons at risk to hazardous HCW and minimizing indirect impacts from environmental exposures to HCW;
- Contribution to the global effort to improve provision of safe water, sanitation, and hygiene (WASH) in HCFs; and curb the proliferation of diseases and environmental problems caused by pollution and contaminants resulting from improper handling of HCW;
- Committed compliance of HCF to the regulatory laws, policies, and guidelines required by national and local authorities in observing proper HCWM;
- Prevention of any long-term liability resulting to any contravention or violation incurred in the implementation of HCWM laws;
- Advancing of community ecological awareness and relationship by demonstrating commitment and dedication in implementation of HCWM programs and activities;
- Increase of socio-economic benefits resulting from the effective and efficient application of HCWM laws, policies, and procedures;
- Sustainability of the HCWM Program of HCFs including evidences of continuous improvement, less events of accidental exposure and incidents of injury among HCW handlers; and
- Resiliency of HCFs in the face of emergencies, disasters, threats of emerging pathogens and diseases, and ever-changing socio-cultural and regulatory changes that impact the efficiency and effectiveness of HCWM implementation.

2 Health Care Waste Source, Categorization, and Characterization

2.1 General Definition of HCW¹

“Health care waste” (HCW) includes all the solid and liquid waste generated as a result of any of the following:

- Diagnosis, treatment, or immunization of human beings;
- Research pertaining to the above activities;
- Research using laboratory animals for the improvement of human health;
- Production or testing of biological products; and
- Other activities performed by an HCF defined as an institution that has health care as its core service, function, or business.

In addition, HCW includes the same types of waste originating from minor and scattered sources, such as waste produced in the course of health care undertaken in the home (e.g., home dialysis, self-administration of insulin, recuperative care).

2.2 Categorization of HCW

HCW can be broadly categorized into “hazardous” and “non-hazardous” waste types.² Each category is described in detail in the succeeding sub-sections.

Figure 1: Categories of health care waste

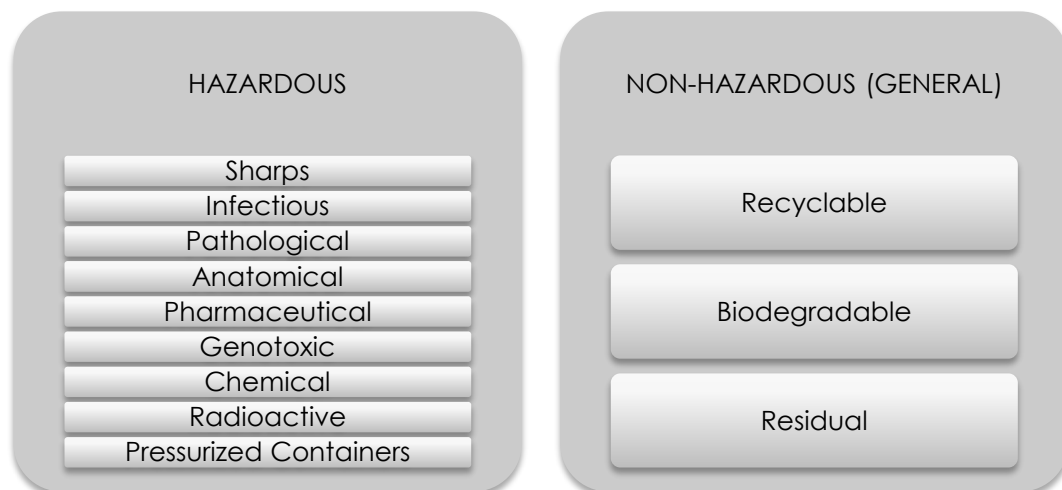

¹ As provided in the Health Care Waste Management Manual, 3rd Edition (DOH, 2011)

² Adopted from Safe Management of Wastes from Health-Care Activities, 2nd Edition (WHO, 2014)

2.2.1 Hazardous HCW

Hazardous HCW refers to waste that may pose a variety of environmental and health risks. It can be further classified into sharps waste, infectious waste, pathological and anatomical waste, pharmaceutical waste, genotoxic waste, chemical waste, radioactive waste, and pressurized containers.

Box 1: HCW covered in the classification of hazardous wastes under DAO 2013-22

Classification of Hazardous Wastes as per DENR Administrative Order No. 2013-22:

Class	Waste Number
Wastes with Cyanide	A101
Acid Wastes	B201 to B299
Alkali Wastes	C301 to C399
Wastes with Inorganic Chemicals	D401 to D499
Reactive Chemical Wastes	E501 to E599
Inks/Dyes/Pigments/Paint/Resins/Latex/Adhesives/Organic Sludge	F601 to F699
Waste Organic Solvents	G703 to G704
Organic Wastes	H802
Oil	I101 to I104
Containers	J201
Stabilized Waste	K301 to K303
Organic Chemicals	L401 to L404
Miscellaneous Wastes	M501 to M507

HCW may fall under the following sub-classifications of Miscellaneous Wastes (Class M):

- **Pathological or Infectious Wastes (Waste No. M501)**
Includes health care wastes from hospitals, medical centers, and clinics containing pathological, pathogenic, and infectious wastes, sharps, and others
- **Pharmaceuticals and Drugs (Waste No. M503)**
Expired pharmaceuticals and drugs stocked at producers and retailers' facilities which contain hazardous constituents harmful to the environment such as antibiotics, veterinary and phytopharmaceuticals, and others

2.2.1.1 Sharps Waste

Sharps are considered as the most hazardous HCW and must be managed with utmost care. This is because of the double danger it poses—it can cause accidental pricks, cuts, or punctures; it can also potentially spread infection through these injuries. Examples of sharps include needles, syringes, scalpels, saws, blades, broken glass, infusion sets, knives, nails, and other items that can cause a cut or puncture wound. Whether or not they are infected, such items are usually considered highly hazardous and should be treated as if potentially infected.

2.2.1.2 Infectious Waste

This type of waste is most likely to contain pathogens (bacteria, viruses, parasites, or fungi) in sufficient concentration or quantity to cause diseases in susceptible hosts. Examples of infectious waste include:

- a) Cultures and stocks of infectious agents from laboratory work;

- b) Wastes from surgeries and autopsies on patients with infectious diseases (e.g., tissues, materials or equipment that have been in contact with blood or other body fluids);
- c) Wastes from infected patients in isolation wards (e.g., excreta, dressings from infected or surgical wounds, clothes heavily soiled with human blood or other body fluids);
- d) Wastes that have been in contact with infected patients undergoing hemodialysis (e.g., dialysis implements such as tubing and filters, disposable towels, gowns, aprons, gloves, and laboratory coats);
- e) Infected animals from research laboratories; and
- f) Other instruments or materials that have been in contact with infected persons or animals.

Among these are highly infectious wastes (see **PART IV** for definition of terms) that require disinfection at source, such as microbial cultures and stocks of highly infectious agents from medical analysis laboratories and body fluids from patients with highly infectious diseases. Special requirements regarding management of infectious waste must be imposed whenever waste is known or – based on medical experience – expected to be contaminated with causative agents of diseases and when this contamination gives cause for concern that the disease might spread.

Box 2: Highly infectious diseases

Based on WHO Laboratory Biosafety Manual, 3rd edition (2004):

Highly infectious disease refers to those causative organisms under Biosafety Levels III and IV, such as Severe Acute Respiratory Syndrome (SARS), Human Immunodeficiency Virus (HIV), Acquired Immunodeficiency Syndrome (AIDS), pulmonary tuberculosis (PTB), anthrax, and Ebola.

As per DOH Administrative Order 2010-33:

Considered as **dangerous communicable diseases** are Hepatitis B and C, rabies, Invasive Group A streptococcal infections, transmissible spongiform encephalitis (e.g., Creutzfeldt-Jakob disease and mad cow disease), HIV/AIDS, meningococemia, viral hemorrhagic fevers (e.g., African Ebola, Lassa or Marburg), yellow fever, plague, SARS, among others.

2.2.1.3 Pathological and Anatomical Waste

Pathological waste could be considered a subcategory of infectious waste but is often classified separately – especially when special methods of handling, treatment, and disposal are used. It consists of tissues, organs, body parts, blood, body fluids, and other waste from surgery and autopsies, including human fetuses and animal carcasses. Within this category, recognizable human or animal body parts are also called anatomical waste.

2.2.1.4 Pharmaceutical Waste

Pharmaceutical waste includes expired, spilt, and contaminated pharmaceutical products, drugs, vaccines, and sera that are no longer required and need to be disposed of appropriately. This category also includes discarded items used in handling of pharmaceuticals, such as bottles, vials, or boxes with residues, gloves, masks, and connective tubing.

2.2.1.5 Genotoxic including Cytotoxic Waste

Genotoxic waste is highly hazardous may have mutagenic (capable of inducing a genetic mutation), teratogenic (capable of causing defects in an embryo or fetus), or carcinogenic (cancer-causing) properties. Disposal of genotoxic waste raises serious safety problems, both inside hospitals and after disposal, and should be given special attention.

Genotoxic waste may include certain cytostatic drugs vomit, urine, or feces from patients treated with cytostatic drugs, chemicals, and radioactive material.

Technically, genotoxic means toxic to the deoxyribonucleic acid (DNA); cytotoxic means toxic to the cell; cytostatic means suppressing the growth and multiplication of the cell; antineoplastic means inhibiting the development of abnormal tissue growth; and chemotherapeutic means the use of chemicals for treatment, including cancer therapy. Genotoxic waste causes damage to the cell's DNA. This includes certain antineoplastic (anti-tumor) and cytotoxic (cell-killer) drugs. This type of waste is highly hazardous and may have mutagenic, teratogenic, or carcinogenic effects.

Box 3: Categories of harmful cytotoxic drugs

Harmful cytotoxic drugs can be categorized as follows:

- **Alkylating Agents:** also called DNA-damaging agents; cause alkylation of DNA nucleotides, which leads to cross-linking and miscoding of the genetic stock (e.g., vesicant drugs – acclarubicin, mechlorethamine, cisplatin, mitomycin; irritant drugs – carmustine, cyclophosphamide, dacarbazine, ifosfamide, melphalan, streptozocin, thiotepa)
- **Anti-metabolites:** imitate the role of purine and pyrimidine as the building blocks of DNA thus inhibiting the biosynthesis of nucleic acids in the cell (e.g., irritant: methotrexate, fludarabine, cytarabine)
- **Mitotic Inhibitors:** prevent cell division
- **Intercalating Agents:** wedge between the DNA bases, affecting the structure of the DNA and preventing polymerase and other DNA binding proteins from functioning properly (e.g., vesicant drugs – amsacrine, dactinomycin, daunorubicin, doxorubicin, epirubicin, pirarubicin, zorubicin; irritant drugs – mitoxantrone)
- **Plant Alkaloids and Terpenoids:** inhibit microtubule function thereby halting cell division. Examples: vinca alkaloids derived from the *Catharanthus roseus* plant or *Tsitsirika* (e.g., vesicant drugs – vinblastine, vincristine, vindesine, vinorelbine)
- **Podophyllotoxins:** prevent cell division by inhibiting the cell from entering the G1 Phase;

also affect DNA synthesis; derived from Podophyllum peltatum or Mayapple (e.g., irritant drugs – teniposide)

Cytotoxic waste is generated from several sources and includes the following:

- Contaminated materials from drug preparation and administration, such as syringes, needles, gauges, vials, and packaging;
- Outdated drugs, excess (leftover) solutions, and drugs returned from the wards; and
- Urine, feces, and vomit from patients, which may contain potentially hazardous amounts of the administered cytostatic drugs and/or of their metabolites, and which shall be considered genotoxic for at least 48 hours and sometimes up to 1 week after drug administration.

It is necessary for patients who are taking cytotoxic medication to have a separate water closet, which is exclusive for the use of these patients. This will ensure that other patients will not be exposed to cytotoxic drugs. Moreover, it will also ensure that the urine, vomit, excreta, and other body fluids coming from these patients will be adequately treated before these wastes are mixed with other wastes in the Sewage Treatment Plant (STP).

2.2.1.6 Chemical Waste

Chemical waste consists of discarded solid, liquid, and gaseous chemicals used in diagnostic and experimental work and in cleaning, housekeeping, and disinfecting procedures.

Chemical waste is considered hazardous if it has at least one of the following properties:

- **Toxic:** chemicals that have the capacity to harm biological tissue;
- **Reactive:** chemicals that can react by themselves when exposed to heat, pressure, shock, friction, catalyst presence or by contact with air or water;
- **Flammable:** chemicals that ignite/burn easily in normal working temperatures (e.g., chemicals with flashpoint below 37.8°C or 100°F);
- **Corrosive:** chemicals that can cause severe burns to skin and other biological tissues including eyes and lungs (e.g., acids of pH<2 and bases of pH>12); and
- **Oxidizing:** liquid or solid chemicals that readily give off oxygen or other oxidizing substances (such as bromine, chlorine, or fluorine); also include materials that react chemically to oxidize combustible (burnable) materials; this means that oxygen combines chemically with the other material in a way that increases the chance of a fire or explosion.

The most common types of hazardous chemicals used in health care, and the most likely to be found in HCW, are as follows:

- Formaldehyde is a significant source of chemical waste in hospitals. It is used to clean and disinfect equipment (e.g., hemodialysis or surgical equipment); to preserve specimens; to disinfect liquid infectious waste; and in pathology, autopsy, dialysis, embalming, and nursing units.
- Photographic fixing and developing solutions are used in X-ray departments where photographic film continues to be used. The fixer usually contains 5–10% hydroquinone, 15% potassium hydroxide, and less than 1% silver. The developer contains approximately 45% glutaraldehyde. Acetic acid is used in both “stop” baths and fixer solutions.
- Waste organic chemicals generated in HCFs include disinfecting and cleaning solutions, vacuum-pump and engine oils, insecticides, and rodenticides. Waste inorganic chemicals consist mainly of acids, alkalis, oxidants, and reducing agents. Wastes containing solvents are generated in various departments of a hospital, including pathology and histology laboratories and engineering. Solvents include halogenated and non-halogenated compounds. Although nearly any chemical could potentially be found in a health care or research laboratory, some are more commonly found:
 - Disinfecting equipment and materials are important to the accuracy of laboratory functions, so a range of disinfecting solutions is often found in laboratories.
 - Many laboratories have automated chemical analyzer systems. These systems contain many reagent reservoirs and reagents with preservatives.
 - Common solvents used in the laboratory include xylene, ethanol, toluene, and methanol.
 - Sodium azide is often used as a preservative in a variety of laboratory reagents usually at concentrations of less than 0.1%.
- Wastes from materials with high heavy metal contents represent a subcategory of hazardous chemical waste and are usually highly toxic. Heavy metals refer to metallic chemical elements that have a high density and are relatively toxic at low levels. Heavy metals have a specific gravity lesser than five times the specific gravity of pure water, which is 1 at 4°C. These cannot be degraded nor destroyed by the body. Thus, heavy metals are bio-persistent and tend to bio-accumulate.

Box 4: Examples of heavy metals found in HCW

- *Mercury* is a naturally occurring silvery-white liquid metal that readily vaporizes. When released to the air, mercury is transported and deposited globally. Mercury ultimately accumulates in the lake bottom in the form of sediments, where it is transformed into its more toxic organic form, methyl mercury, which accumulates in fish tissue. There are 3 types of mercury: elemental, inorganic, and organic. Mercury waste is typically generated by spillage from broken clinical equipment (mercury thermometer, sphygmomanometer, etc.). Residues from dental laboratories have high mercury content. Whenever possible, spilled drops of mercury shall be recovered.
- *Cadmium* is a soft, bluish white metal that has a rapid electrical and thermal conductivity. It is highly resistant to stress and corrosion. Cadmium waste comes mainly from discarded batteries, dental alloys, pigments, and electronic devices.
- *Lead* is a bluish white lustrous metal that is highly malleable and ductile. Lead waste usually comes from batteries, petroleum, rolled and extruded products, ammunition and pipes. Also, certain “reinforced wood panels” containing lead is still being used in radiation proofing in X-ray and diagnostic departments.

Box 5: Non-hazardous chemical waste

Non-hazardous chemical waste consists of chemicals with none of the aforementioned properties. Examples are sugars, amino acids, and certain organic and inorganic salts.

2.2.1.7 Radioactive Waste

Radioactive wastes are materials contaminated with radionuclides. They are produced as a result of procedures such as in vitro analysis of body tissue and fluid, in vivo organ imaging and tumor localization, and various investigative and therapeutic practices.

Radionuclides used in health care are in either unsealed (or open) sources or sealed sources. Unsealed sources are usually liquids that are applied directly, while sealed sources are radioactive substances contained in parts of equipment or encapsulated in unbreakable or impervious objects, such as pins, “seeds” or needles.

Radioactive HCW often contains radionuclides with short half-lives (i.e., half of the radionuclide content decays in hours or a few days); consequently, the waste loses its radioactivity relatively quickly. However, certain specialized therapeutic procedures use radionuclides with longer half-lives; these are usually in the form of small objects placed on or in the body and may be reused on other patients after sterilization. Waste in the form of sealed sources may have a relatively high radioactivity but is only generated in low volumes from larger medical and research laboratories. Sealed sources are generally returned to the supplier and should not enter the waste stream.

The waste produced by health care and research activities involving radionuclides and related equipment maintenance and storage can be classified as follows:

- sealed sources;
- spent radionuclide generators;
- low-level solid waste (e.g., absorbent paper, swabs, glassware, syringes, vials);
- residues from shipments of radioactive material and unwanted solutions of radionuclides intended for diagnostic or therapeutic use;
- liquid immiscible with water, such as liquid scintillation counting;
- residues used in radioimmunoassay, and contaminated pump oil;
- waste from spills and from decontamination of radioactive spills;
- excreta from patients treated or tested with unsealed radionuclides;
- low-level liquid waste (e.g., from washing apparatus); and
- gases and exhausts from stores and fume cupboards.

2.2.1.8 *Pressurized Containers*

Many types of gas are used in health care and are often stored in portable pressurized cylinders, cartridges, and aerosol cans. Many of these are reusable, once empty or of no further use (although they may still contain residues). However, certain types – notably aerosol cans – are single-use containers that require disposal. Whether inert or potentially harmful, gases in pressurized containers should always be handled with care; containers may explode if incinerated or accidentally punctured.

2.2.2 *Non-hazardous HCW or General Waste*

More commonly known as “general waste,” non-hazardous HCW refers to waste that has not been in contact with infectious agents, hazardous chemicals, or radioactive substances and does not pose any special handling problem or hazard to human health or to the environment. General waste is usually similar in characteristics to municipal solid waste and comes mostly from the administrative and housekeeping functions of HCFs. Non-hazardous HCW can be further classified into recyclable waste, biodegradable waste, and (c) residual waste that is neither recyclable nor biodegradable.

2.2.2.1 *Recyclable General Waste*

The following are recyclable materials commonly found in HCFs:

- **Paper products:** corrugated cardboard boxes, office paper, computer printout paper, colored ledger paper, newspaper, magazines
- **Aluminum:** beverage cans, food cans, other aluminum containers
- **Plastics:** polyethylene terephthalate (PET) bottles, high density polyethylene (HDPE) containers for food and mild solutions, polypropylene

(PP) plastic bottles for saline solutions or sterile irrigation fluids, polystyrene packaging

- Glass: clear, colored, or mixed glass
- Wood: scrap wood, shipping pallets

In addition, durable goods such as used furniture, bed frames, carpets, curtains, and dishware, as well as computer equipment, printer cartridges and photocopying toners, are also potentially reusable.

2.2.2.2 Biodegradable General Waste

This includes kitchen waste, leftover food of patients with non-communicable disease, flowers, and garden waste such as cut grasses or tree trimmings that can be composted.

2.2.2.3 Residual General Waste

This includes general wastes that do not belong to the previous two categories (recyclable and biodegradable).

2.3 Generation of HCW

The volume and characteristic of HCW generated depends on the type of HCF and the number of clients served. An HCF is defined as an institution that has health care as its core service, function, or business. Health care pertains to the maintenance or improvement of the health of individuals or populations through the prevention, diagnosis, treatment, rehabilitation, and chronic management of disease, illness, injury, and other physical and mental ailments or impairments of human beings.³ Different types of HCFs can be viewed as major or minor sources of HCW, according to the quantities produced.

2.3.1 Sources of HCW

Table 1 presents the type of HCW typically generated by HCFs. The source often characterizes the composition of HCW being generated. Knowing the types and quantities of HCW generated in an HCF is important in understanding the hazard and risk that people, community, and the environment maybe facing.

³ DOH-HFDB Health Facilities Dictionary

Table 1: Type of HCW typically generated by HCFs

Classification/Facility	Type of HCW Generated							
	General	Sharps	Highly Infectious	Pathological	Anatomical	Pharmaceuticals	Chemical	Radioactive
PRIMARY CARE FACILITY								
Urban/Rural Health Unit	✓	✓	✓	✓	✓	✓	✓	
Barangay Health Station	✓	✓	✓	✓	✓	✓	✓	
Medical Outpatient Clinic	✓	✓	✓	✓		✓	✓	
Medical Facilities for Overseas Workers and Seafarers	✓	✓	✓	✓		✓	✓	
Dental Clinic	✓	✓	✓	✓		✓	✓	
Birthing Home	✓	✓	✓	✓	✓	✓	✓	
HOSPITAL								
General Hospital (Level 1, 2, 3)	✓	✓	✓	✓	✓	✓	✓	✓
Specialty Hospital	✓	✓	✓	✓	✓	✓	✓	
SPECIALIZED HEALTH FACILITY								
Specialized Outpatient Clinic	✓	✓	✓	✓		✓	✓	
Dialysis Clinic	✓	✓	✓	✓		✓	✓	
Ambulatory Surgical Clinic	✓	✓	✓	✓	✓	✓	✓	
Physical Therapy and Rehabilitation Facility	✓							
Drug Abuse Treatment and Rehabilitation Facility	✓					✓	✓	
Blood Services Facilities	✓	✓	✓	✓			✓	
Pharmaceutical Outlet	✓	✓				✓	✓	
Human Stem Cell Clinic	✓	✓				✓	✓	
Quarantine Clinic	✓	✓	✓	✓		✓	✓	
DIAGNOSTIC FACILITY								
Radiologic Facility	✓						✓	✓
Clinical Laboratory Facility	✓	✓	✓	✓			✓	
National/Subnational Reference Laboratory	✓	✓	✓	✓			✓	
Drug Testing Facility	✓	✓	✓	✓			✓	
HIV Testing Facility	✓	✓	✓	✓			✓	
Newborn Screening Reference Center	✓	✓	✓	✓		✓	✓	
Newborn Hearing Reference Center	✓	✓	✓	✓		✓	✓	
Nuclear Medicine Facility	✓	✓	✓	✓		✓	✓	✓
TRANSITIONAL CARE FACILITY								
Custodial Care Facility (Nursing Home, Hospice)	✓	✓	✓	✓		✓	✓	
Mental Health Facility/Custodial Psychiatric Facility	✓	✓	✓	✓		✓	✓	
Infirmary	✓	✓	✓	✓		✓	✓	
Sanitarium	✓	✓	✓	✓		✓	✓	
Halfway House	✓	✓				✓	✓	
OTHERS								
Animal Bite Center/Animal Bite Treatment Center	✓	✓				✓		
Home Treatment	✓	✓		✓		✓		
Traditional and Complementary Medicine Clinic	✓	✓						

Note: The definition and functions of each type of HCF are provided in PART IV of this Manual.

Box 6: Volume of generated M501 and M503 as per EMB data

The Hazardous Waste Management Section of the DENR-EMB Environmental Quality Division provided the following data on the quantity (in tons per year) of Pathological or Infectious Waste (M501) and Pharmaceuticals and Drugs (M503) generated from year 2015 to 2017:

Pathological or Infectious Waste (M501)

Region	Volume of M501 Generated (tons/year)		
	2015	2016	2017
I	1,108.17039	461.22000	1,259.57000
II	0.00000	6.14230	5.94730
III	13,404.00000	376.00000	916.04000
IV-A	4,740.50000	3,702.46000	4,716.91400
IV-B	0.00000	8.45900	1.98100
V	328.92383	600.23803	348.19200
VI	937.25900	66.70000	534.34327
VII	301.57900	162.67400	570.62900
VIII	9.20400	4.34015	23.72140
IX	35.65087	92.42337	2,466.74900
X	157.86450	0.00000	154.87512
XI	36,521.64100	145.71610	3,852.53320
XII	0.00000	163.73000	151.51470
NCR	80,451.54571	2,899.37900	20,212.73400
CAR	51.38132	28.82418	129.25190
CARAGA	4,125.30385	10.14937	17.54880
TOTAL	142,173.02000	8,728.46000	35,362.54000

Source: EMB Regional Offices

Pharmaceuticals and Drugs (M503)

Region	Volume of M503 Generated (tons/year)		
	2015	2016	2017
I	16.78208	11.36000	627.90000
II	0.00000	0.32640	2.74140
III	9,529.00000	769.00000	156.27000
IV-A	7,148.74000	657.62000	190.47900
IV-B	0.00000	0.00000	0.08000
V	6.53864	15.35700	11.25300
VI	6.89900	1.22300	30.77714
VII	18.65328	71.11800	68.59000
VIII	0.11000	0.97750	1.28770
IX	1.47849	22,306.02211	4.26492
X	2.41996	0.00000	4.42715
XI	1,008.15210	1.47300	3.88270
XII	0.00000	0.00000	0.11050
NCR	20,700.96880	331.21500	1,685.43800
CAR	0.35194	1.40609	1.69990
CARAGA	0.00000	0.00046	0.00001
TOTAL	38,440.09000	24,167.10000	2,789.20000

Source: EMB Regional Offices

2.3.2 General Composition of HCW

The general composition of HCW is often characteristic of the type of HCF and its health care activities. Knowing the types and quantities of waste produced in an HCF is an important first step in safe management. Many factors affect the rate of waste generation:

- Type or level of facility (e.g., clinic, provincial hospital);
- Level of activity (often measured in terms of the number of occupied beds, number of patients per day, and/or number of staff);
- Type of department (e.g., general ward, surgical theatre, office);
- Location (rural or urban);
- Regulations or policies on waste classification;
- Segregation practices;
- Temporal variations (e.g., weekday versus weekend, seasonal);
- Level of infrastructure development of the country.

Variations in waste generation according to the type or level of HCF, or between rural and urban HCFs, may reflect differences in services provided, scale, organizational complexity, availability of resources and the number of medical and other staff.

Average waste generation rates are calculated in kilograms (kg) per day or per year. Kilograms per occupied bed per day, and kg per patient per day, are used especially when comparing different HCFs with different levels of activities. If inpatient occupancy rates and the daily number of outpatients are not available, the total number of beds is often used to estimate kg per bed per day.

Figure 2: Comparison of estimated daily waste generation in two types of HCFs

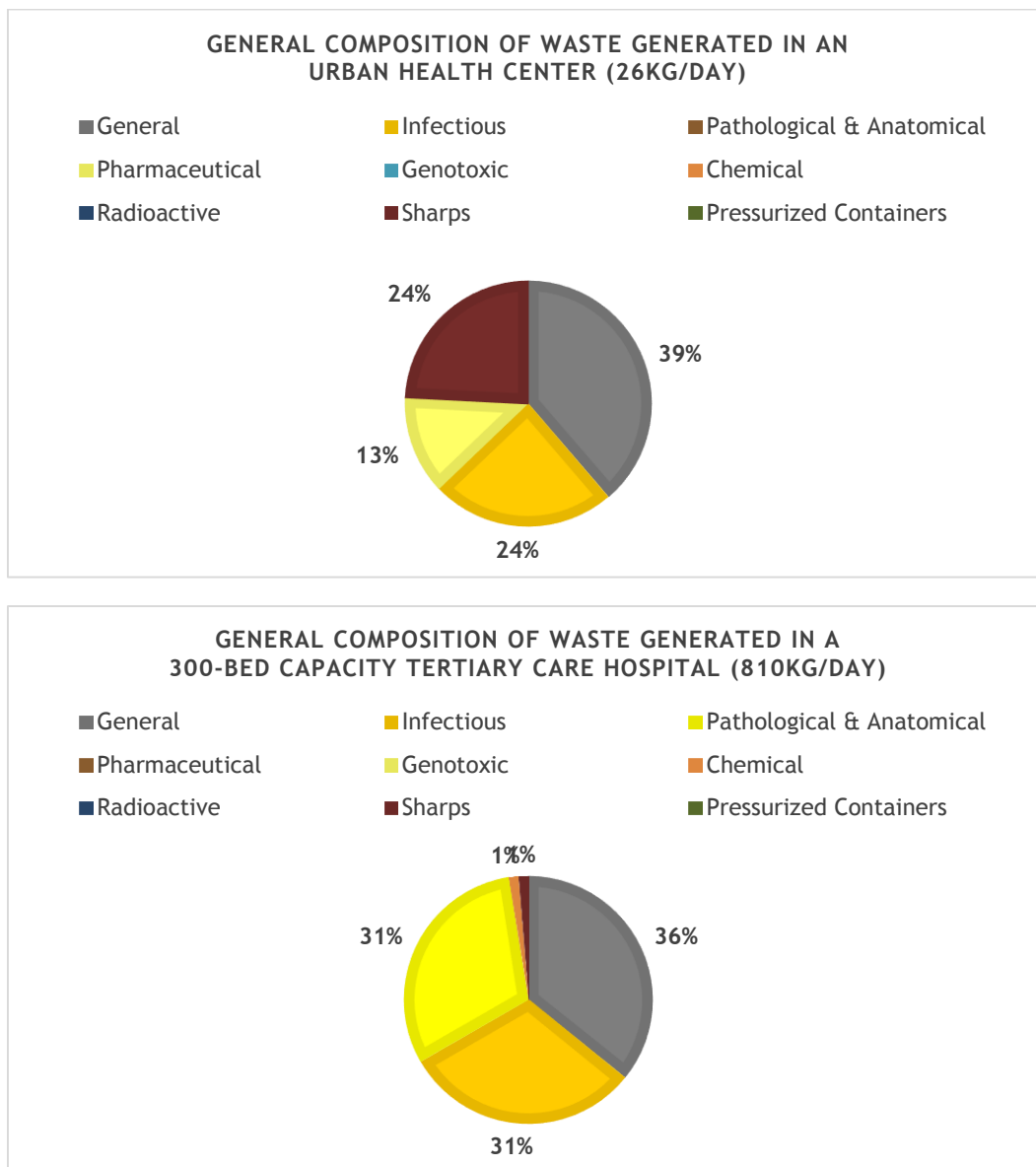

Source: Survey on health care waste generation and management (LCI, 2019)

2.4 Waste Assessment Approaches⁴

HCW generation data are best obtained from quantitative waste assessments. An assessment entails defining goals, planning, enlisting the cooperation of staff, procurement of equipment (e.g., weighing scales, personal protective equipment), data collection, analysis, and recommendations. The process of waste assessment provides an opportunity to improve current practices, sensitize health workers about waste, and determine the potential for waste minimization. Implementing rigorous segregation can avoid over-sizing of equipment and result in cost savings.

Described in the following sub-sections are three common approaches to conducting a waste assessment: 1) records examinations; 2) facility walk-throughs; and 3) waste sorts. An assessment might require just one of these activities or a combination of approaches. The team should determine the best approach for the organization based on factors such as facility type and size, complexity of the waste stream, availability of resources (money, time, labor, equipment) to implement the waste reduction program, and scope of waste reduction program.

2.4.1 Records Examination

Examining records can provide insight into the organization's waste generation and removal patterns. The types of records that might be useful include:

- Purchasing, inventory, maintenance, and operating logs;
- Supply, equipment, and raw material invoices;
- Waste hauling and disposal records and contracts; and
- Contracts with recycling facilities and earned revenues from recycling.

2.4.2 Walk-through

A walk-through involves touring the facility, observing different function areas or departments' activities, and talking with employees and managers about waste-producing activities and equipment. A walk-through is a relatively quick way to examine the facility's waste-generating practices. Specifically, a walk-through will enable the team to:

- Observe the types and relative amounts of waste produced;
- Identify waste-producing activities and equipment;
- Detect inefficiencies in operations or in the way waste moves through the organization;
- Observe the layout and operations of various departments;

⁴ From US EPA Archive: <https://archive.epa.gov/epawaste/conserve/smm/wastewise/web/html/approach.html>

- Assess existing space and equipment that can be used for storage, processing recyclables, and other activities;
- Assess current waste reduction efforts; and
- Collect additional information through interviews with supervisors and employees.

2.4.3 Waste Sort

A waste sort involves the physical collection, sorting, and weighing of a representative sample of the facility's waste. The goal of a waste sort is to identify each waste component and calculate its percentage share in the total waste generation. Waste sorts can focus on the facility's entire waste stream or target specific functional areas.

Some organizations choose to assemble and measure one day's worth of waste. Others choose to assemble a portion of the waste from each department for measuring. Any which way, the team should consider whether waste generation varies significantly enough from one day to the next to distort results. Multi-day sampling provides a more accurate representation of the facility's waste generation.

The team will also need to determine which waste categories to quantify. Typically, the major components of an organization's waste stream include paper, plastic, glass, metal, and organic material such as yard trimmings and food scraps. If possible, the team should strive to separate and measure the waste sample as completely as possible. These measurements will be useful when determining which materials can be exchanged, reused, sold, or recycled.

2.4.4 Characterization of Physicochemical Composition

One aspect of a waste assessment is the characterization of the physicochemical composition of HCW. This information is essential in developing waste minimization plans. Setting up an efficient recycling program requires an understanding of the composition of general (non-hazardous) waste.

Physicochemical parameters of the infectious portion of the waste stream are useful in establishing equipment specifications or operating parameters for treatment technologies. For example, some steam and microwave treatment systems rely on a minimum amount of moisture to be present in waste; some chemical systems are affected by the organic load and water content; and incineration is influenced by the percentage of incombustibles (ash), heating (calorific) value and moisture content of waste.

Physical properties, such as bulk density (uncompacted mass per unit volume), are used to estimate storage, transport, and treatment chamber capacities, as well as specifications for compactors, shredders, and other size-reduction equipment. Common to any waste classification, the physicochemical characteristics of HCW

will vary between HCFs within a country.

The approximate chemical composition of hospital waste is 37% carbon, 18% oxygen, and 4.6% hydrogen, as well as numerous other elements (Liberti et al., 1994). The toxic metals that are found in HCW and that are readily emitted during combustion include lead, mercury, cadmium, arsenic, chromium, and zinc. In the past, elemental compositions were used to estimate the products of combustion, but this can be misleading since HCW varies widely.

Moreover, persistent organic pollutants (POPs), such as polychlorinated dioxins and furans, cannot be predicted reliably from basic elemental compositions. These dioxins and furans are toxic at extremely low concentrations. However, decreasing the percentage of halogenated plastics (such as polyvinyl chloride) reduces the amounts of hydrogen chloride and other halogenated pollutants. As much as 40% of plastic waste in modern hospitals is chlorinated plastics.

3 Risks Associated with Health Care Waste

As presented in the previous chapter, the large component of non-hazardous HCW is similar to municipal waste and should not pose any higher risk than waste produced in households. It is the smaller hazardous HCW component that needs to be properly managed so that the health risks from exposure to known hazards can be minimized. Protection of the health of staff, patients, and the general public is the fundamental reason for implementing a system of HCWM. This chapter is concerned with identifying the types of hazards associated with HCW and who may be at risk from them by describing the public and environmental health impacts that need to be controlled.

3.1 Persons at Risk

All individuals coming into proximity with hazardous HCW are potentially at risk, including those who generate hazardous HCW, as well as those who either handle such waste or are exposed to it as a consequence of improper management.

The main groups of people at risk to potential health hazards associated with HCW are the following:

- HCF staff, e.g., doctors, nurses, auxiliaries, and maintenance personnel;
- Patients in the HCF or receiving home care;
- Visitors to the HCF;
- Workers providing support and allied services to the HCF, such as laundry;
- Workers transporting hazardous HCW to treatment, storage, and disposal facilities; and
- Workers and operators of waste management facility (e.g., sanitary landfill and TSD facilities) including informal recyclers or scavengers.

The general public could also be at risk whenever hazardous HCW is abandoned or disposed of improperly.

3.2 Types of Hazard and Mode of Transmission

Exposure to hazardous HCW can result to disease or injury. The hazardous nature of HCW may be due to one or more of the following characteristics: presence of infectious agents; genotoxic or cytotoxic chemical composition; presence of toxic or hazardous chemicals or biologically aggressive pharmaceuticals; presence of radioactivity; and presence of sharps.

Box 7: Chain of infection

The *Chain of Infection* is a model used to understand the infection process. The concept is depicted as a circle of links, each representing a component in the cycle. Each link must be present and in sequential order for an infection to occur. The links are infectious agent, reservoir, portal of exit from the reservoir, mode of transmission, and portal of entry into a susceptible host. Understanding the characteristics of each link and the means by which the chain of infection can be interrupted provides the HCF workers with methods for supporting vulnerable patients, preventing the spread of infection and self-protection. Breaking any link in the chain will prevent infection, although control measures are most often directed at the “mode of transmission.”

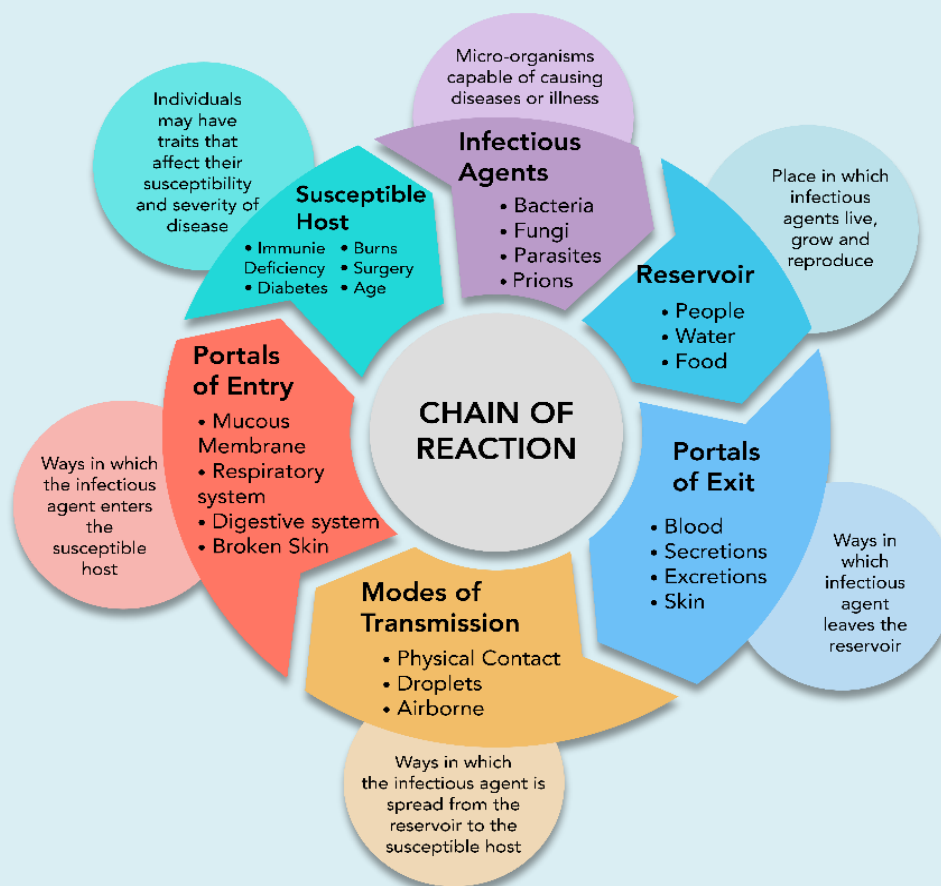

The elements of infection in the context of HCW are:

- Some components of HCW are potential reservoir of disease-causing microorganisms such as culture dishes, liquid blood, pathological waste, etc.
- The infective dose depends on the virulence of the microorganisms, the portal of entry, and the susceptibility of the host.
- Modes of transmission may involve contact (e.g., contaminated needles or blood splatter), vehicle-borne (e.g., contaminated wastewater), air-borne (e.g., aerosolized pathogens from broken culture dishes or the rupture of yellow bags), and vector-borne (e.g., rodents in an HCW storage area) transmission.
- Portals of entry include breaks in the skin and mucous membranes (e.g., needle-stick injuries or blood splashes into the mucous membranes), the respiratory tract (inhalation of pathogenic aerosols), etc.
- Potential susceptible host include HCF workers, waste handlers, patients, and visitors in the HCF, landfill operators, scavengers, and the general public.

3.2.1 Hazards from Infectious, Sharps, Pathological and Anatomical Wastes

Infectious, sharps, pathological and anatomical wastes should always be assumed to potentially contain a variety of pathogenic microorganisms. This is because the presence or absence of pathogens cannot be determined at the time a waste item is produced and discarded into a container. Pathogens in infectious waste that is not well-managed may enter the human body through several routes:

- through a puncture, abrasion, or cut in the skin;
- through the mucous membrane;
- by inhalation; or
- by ingestion.

Examples of infections that might be caused by exposure to HCW are listed in **Table 2**.

Table 2: Potential infections caused by exposure to HCW

Type of Infection	Examples of Causative Agent	Mode of Transmission
Gastroenteric infection	Enterobacteria, e.g. Salmonella, Shigella spp.; Vibrio cholera; Giardia lambda; Clostridium difficile; helminths	Feces and/or vomit
Respiratory infection	Mycobacterium tuberculosis; measles virus; Streptococcus pneumonia, Severe Acute Respiratory Syndrome	Inhaled secretions; saliva
Ocular infection	Herpes virus	Eye secretions
Genital infection	Neisseria gonorrhoeae; herpes virus	Genital secretions
Skin infection	Streptococcus spp	Pus
Anthrax	Bacillus anthracis	Skin secretions
Meningitis	Neisseria meningitides	Cerebrospinal fluid
Acquired Immunodeficiency Syndrome (AIDS)	Human immunodeficiency virus	Blood, sexual secretions, body fluids
Hemorrhagic fever	Junin, Lassa, Ebola, and Marburg viruses	Feces and all body secretions
Septicemia	Staphylococcus spp.	Blood
Bacteremia	Coagulase-negative Staphylococcus spp.; (including Methicillin-resistant S. aureus); Enterobacter, Enterococcus, Klebsiella, and Streptococcus spp	Nasal secretion, skin contact
Candidemia	Candida albicans	Blood
Viral Hepatitis A	Hepatitis A virus	Feces
Viral Hepatitis B and C	Hepatitis B and C viruses	Blood and body fluids
Avian influenza	H5N1 virus	Blood, feces

Source: Health Care Waste Management Manual, 3rd Edition (DOH, 2011)

3.2.2 Hazards from Chemical and Pharmaceutical Waste

Although chemical and pharmaceutical wastes may be found in small quantities in HCFs, these substances are hazardous. They may cause intoxication, either by acute or by chronic exposure and injuries, including burns. Intoxication can result from absorption of a chemical or pharmaceutical substance through the skin or the

mucous membranes, or from inhalation or ingestion. Injuries to the skin, the eyes or the mucous membranes of the airways can be caused by contact with flammable, corrosive or reactive chemicals (e.g., formaldehyde and other volatile substances). The most common injuries are burns.

Disinfectants are one of the commonly used chemical product in HCFs. It is used in large quantities and is often corrosive. It shall be noted that reactive chemicals may form highly toxic secondary compounds. Like silver, they may also be priming bacteria to become antibiotic resistant (McCay et al., 2010). Where chlorine is used in an unventilated place, chlorine gas is generated as a by-product of its reaction with organic compounds. Consequently, good working practices should be used to avoid creating situations where the concentration in air may exceed safety limits.

Chemical residues discharged into the sewerage system may have adverse effects on the operation of STP or on the natural ecosystems of receiving waters. Similar problems may be caused by pharmaceutical residues, which may include antibiotics and other drugs, heavy metals such as mercury, phenol and derivatives, disinfectants, and antiseptic.

Mercury is highly toxic, especially when metabolized into methyl mercury. It may be fatal if inhaled and harmful if absorbed through the skin. Around 80% of the inhaled mercury vapor is absorbed in the blood through lungs. It may cause harmful effects to the nervous, digestive, respiratory and immune systems. While the use of mercury in HCFs is decreasing, another toxic heavy metal, silver, is being used in even more applications, including nanotechnology. It is a bactericide and large doses can turn a person's skin permanently grey (Silver, 2003).

Obsolete pesticides, stored in leaking drums or torn bags, can directly or indirectly affect the health of anyone who comes into contact with them. During heavy rains, leaking pesticides can seep into the ground and contaminate groundwaters. Poisoning can occur through direct contact with a pesticide formulation, inhalation of vapors, drinking contaminated water or eating contaminated food. Other hazards may include the possibility of spontaneous combustion if improperly stored, and contamination as a result of inadequate disposal, such as open burning or indiscriminate burying (WHO 2014).

3.2.3 Hazards from Genotoxic Waste

The severity of the hazards for health care workers responsible for the handling or disposal of genotoxic waste is governed by a combination of the substance toxicity itself and the extent and duration of exposure. Exposure to genotoxic substances in health care may also occur during the preparation of or treatment with specific drugs or chemicals.

The pathways of exposure are inhalation of dust or aerosols, absorption through the skin, ingestion of food accidentally contaminated with cytotoxic drugs, ingestion

as a result of bad practice, such as mouth pipetting. Exposure may also occur through contact with body fluids and secretions of patients undergoing chemotherapy.

The cytotoxicity of many antineoplastic drugs is cell-cycle-specific, targeted on specific intracellular processes such as DNA synthesis and mitosis. Other antineoplastic substances, such as alkylating agents, are not phase specific, but cytotoxic at any point in the cell cycle. Many cytotoxic drugs are extreme irritants and have harmful local effects after direct contact with skin or eyes. They may also cause dizziness, nausea, headache, or dermatitis. Special care in handling genotoxic waste is therefore essential; any indiscriminate disposal of such waste into the environment could have disastrous ecological consequences.

There are very little data on the long-term health impacts of genotoxic HCW. This is partly because of the difficulty of assessing human exposure to this type of compound. Numerous published studies have investigated the potential health hazard associated with the handling of antineoplastic drugs, manifested by increased urinary levels of mutagenic compounds in exposed workers and an increased risk of abortion. A study by Sessink et al. (1992) demonstrated that exposure of personnel cleaning hospital urinals exceeded that of nurses and pharmacists. These individuals were less aware of the potential danger and took fewer precautions. The concentration of cytotoxic drugs in the air inside hospitals has been examined in several studies designed to evaluate health risks linked to such exposure.

3.2.4 Hazards from Radioactive Waste

Health effects caused by exposure to radioactive substance or contaminated materials can range from reddening of the skin and nausea to more serious problems such as cancer induction and genetic consequences to succeeding generations of the exposed individual. The handling of high activity sources, e.g., certain sealed and unsealed radiation sources used in cancer therapy, poses higher health risks such that adequate protective measures must be established to minimize these risks.

The health hazards from low activity contaminated wastes may arise from external and internal exposures from undetected contaminated working environment and improper handling and storage of radioactive wastes and spent/unused radiation sources. Both the workers and other staff personnel are at risk to this health hazard.

Several accidents resulting from improper disposal of radioactive HCW have been reported. The only recorded accidents involve exposure to ionizing radiations in HCFs as a result of unsafe operation of X-ray apparatuses, improper handling of radiotherapy solutions, or inadequate control of doses of radiation during radiotherapy.

3.2.5 Hazards from Wastewater

Wastewater from HCF is composed of a myriad of materials that pose a hazard to public health and to the environment. Wastewater may contain pathogens such as bacteria, helminths, protozoa, and viruses that are hazardous if the wastewater is inadequately treated or the untreated wastewater is used for irrigation of crops. The salt content in wastewater may also increase soil salinity in the area, rendering the soil useless for agricultural purposes.

Wastewater may also contain trace amounts of metals that can accumulate in the environment. Toxic organic compounds with carcinogenic, teratogenic, and mutagenic effects may also be present in wastewater from HCF. Pharmaceutical residues or their by-products present in the wastewater may also contaminate surface water or ground water, thereby exposing humans through drinking water. Suspended solids in wastewater are generally non-biodegradable and may lead to clogging of drains if not treated.

Pathogens present in the wastewater can cause waterborne diseases and thus can survive in the liquid medium. The people in the HCF and the general public are in danger of contracting these waterborne diseases if the wastewater from the HCF is not given adequate treatment. Several diseases that can be transmitted via wastewater include capylobacteriosis, cholera, cryptosporidiosis, hepatitis A, hepatitis E, and typhoid fever.

3.2.6 Hazards from HCW Treatment Methods

There are occupational hazards associated with waste treatment processes. Some are similar to those common in industries using machinery:

Autoclave and steam disinfection treatment methods can pose potential hazards that need to be managed. Particularly, good maintenance and operation should be undertaken to avoid physical injuries from high operating temperatures and steam generation. Waste treatment autoclaves must also treat the air removed at the start of the process to prevent pathogenic aerosols from being released. This is usually done by treating the air with steam or passing it through a specific filter, e.g., High Efficiency Particulate Air (HEPA) filter or microbiological filter before being released. Furthermore, it needs to be assured that the resulting condensate is decontaminated before release to the wastewater system. Post-waste treatment water contains organic and inorganic contaminants.

HCW treatment mechanical equipment, such as shredding devices and waste compactors, can cause physical injury when improperly operated or inadequately maintained.

Flue gases from waste incinerators may have an impact on people living and working close to a treatment site. The health risk is most serious where an incinerator is improperly operated or poorly maintained. If poorly controlled, emissions from

waste incinerators may cause health concern from particulates (associated with increased cardiovascular and respiratory mortality and morbidity); volatile metals, such as mercury and cadmium (associated with damage to the immune system, neurological system, lungs, and kidneys); and dioxins, furans, and polycyclic aromatic hydrocarbons (which are known carcinogens but may also cause other serious health effects).

Ash from the incineration of hazardous HCW may continue to pose a risk and is considered as hazardous waste. Burnt-out needles and glass may have been disinfected but can still cause physical injury. Furthermore, incinerator ash may contain elevated concentrations of heavy metals and other toxic items, and the ash provides ideal conditions for the synthesis of dioxins and furans, because it is often exposed for a long time to a temperature range of 200–450°C.

Burial of HCW in landfill sites may pose hazards to workers and public. The risks are often difficult to quantify, and the most likely injury comes from direct physical contact with waste items. Chemical contaminants or pathogens in landfill leachate may be released into surface streams or groundwater. On poorly controlled land-disposal sites, the presence of fires and subsurface burning waste poses the further hazard of airborne smoke. The smoke may contain heavy metals and other chemical contaminants that over time may affect the health of site workers and the general public.

3.3 Additional Considerations and Emerging Threats of HCW to Public Health and the Environment

Apart from the risk to the patients and HCF workers, consideration must be given to the adverse impacts of HCW to the general public and the environment. Particularly, attention shall be focused on the possible result of unmanaged waste to air, water, and soil, including the community. Minimizing the risk to public health and the environment will require actions to deal with HCW within the HCF such as proper waste segregation and minimization so that it does not enter the waste stream requiring further treatment before disposal.

While the HCF workers are at greater risk of infection through injuries from contaminated sharps, other workers, and waste management operators outside of the HCF are also at risk. Certain infection, however, spread through media or caused by more resilient agents, may pose a significant risk to the public. For example, the uncontrolled discharges of wastewater from HCF such as field hospitals treating cholera patients are potential source of cholera epidemic. However, the use of strong disinfectant shall be minimized when there are alternatives as these can also chemically pollute the water.

In evaluating the spread or survival of pathogenic microorganisms in the environment, the role of vectors (e.g., rodents and insects) shall be considered. This

applies to management of HCW both within and outside HCF. Vectors such as rats, flies, cockroaches, which feed or breed on organic waste, are well known passive carriers of microbial pathogens; their population may increase dramatically where there is lack of waste management.

Except for waste containing pathogenic cultures or excreta from infected patients, the microbial load of HCW is generally not very high. Furthermore, HCWs do not seem to provide favorable media for the survival of pathogens, perhaps because they frequently contain antiseptics. Results from several studies have shown that the concentration of indicator microorganisms in HCW is generally no higher than in domestic waste and that survival rates are low.

Chemicals used in the HCF are potential sources of water pollution via the sewer system. Chemical waste survey is a prerequisite to the development of an effective waste management program. Any hazardous chemical waste generated shall be dealt with by a proper chemical waste management system. For safety purposes, always refer to the Material Safety Data Sheet (MSDS). Substituting chemicals with substance that have lesser environmental and health impacts is a sound practice. Accidental spillage within the HCF shall also be dealt with accordingly to minimize impact on human health and environment.

Although there is no scientifically documented evidence of widespread illnesses among the general public due to chemical or pharmaceutical waste from hospitals, excreted pharmaceuticals from patients do find their way into waterways, which can contribute to potentially serious environmental effects, including toxicity to wildlife and the generation of antibiotic resistance in bacteria (e.g., Guardabassi et al., 1998).

Better assessment of both risks and effects of exposure would permit improvements in HCWM and in the planning of adequate protective measures. Within HCFs, the surveillance of infection and record keeping are important tools to identify indications of inadequate waste management practices or contamination of the immediate environment. Surveillance allows an outbreak of infection or other hazards to be recognized and investigated. It also provides a basis for introducing control measures, assessing their efficacy, reinforcing routine preventive measures, and determining the level of avoidable infection.

Box 8: Endocrine disruptors

Endocrine disruptors (EDCs) are also found in synthetic chemicals used as industrial solvents, lubricants, and their by-products. These include polychlorinated biphenyls (PCBs), polybrominated biphenyls (PBBs), and dioxins. Other examples of endocrine disruptors include bisphenol A (BPA) from plastics, dichlorodiphenyltrichloroethane (DDT) from pesticides, vinclozolin from fungicides, and diethylstilbestrol (DES) from pharmaceutical agents. Certain metals such as cadmium, mercury, arsenic, lead, manganese, and zinc also disrupt endocrine systems.

Known or Suspected Endocrine Disrupting Chemicals



The most prominent and well-documented health concerns from exposure to EDCs are reproductive and developmental effects. Some of the disorders that have been seen in animal studies include oligospermia (low sperm count), testicular cancer, and prostate hyperplasia in adult males; vaginal adenocarcinoma, disorders of ovulation, breast cancer, and uterine fibroids in adult females. Disruption to thyroid functions, obesity, bone metabolism and diabetes are also linked to exposure endocrine disruptors.

References:

*Canadian Center for Occupational Health and Safety, Endocrine Disruptors Fact Sheets, <https://www.ccohs.ca/oshanswers/chemicals/endocrine.html>
Endocrine Disrupting Chemicals (EDCs), World Health Organization
<https://www.who.int/ceh/risks/cehemerging2/en/>*

Box 9: Antimicrobial resistance

Antimicrobial resistance (AMR) happens when microorganisms (such as bacteria, fungi, viruses, and parasites) change when they are exposed to antimicrobial drugs (such as antibiotics, antifungals, antivirals, antimalarials, and anthelmintics). Microorganisms that develop antimicrobial resistance are sometimes referred to as “superbugs”. As a result, the medicines become ineffective and infections persist in the body, increasing the risk of spread to others.

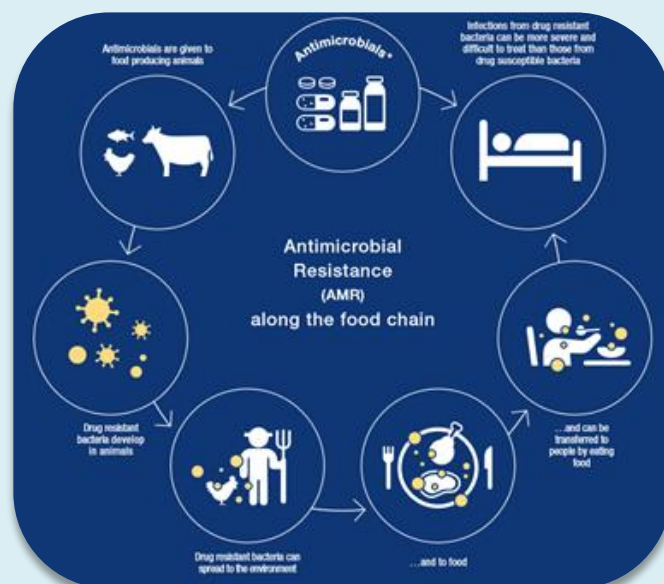

Antimicrobial resistant-microbes are found in people, animals, food, and the environment (in water, soil and air). They can spread between people and animals, including from food of animal origin, and from person to person. Poor infection control, inadequate sanitary conditions and inappropriate food-handling encourage the spread of antimicrobial resistance.

References:

Antimicrobial Resistance, Center for Disease Control and Prevention

<https://www.cdc.gov/drugresistance/about.html>

WHO List of Critically Important Antimicrobials for Human Medicine (WHO CIA List)

<https://www.who.int/en/news-room/fact-sheets/detail/antimicrobial-resistance>

Box 10: Microplastics

A lot of attention has been drawn recently to *microplastics* in freshwater and marine environments and the threat they pose to ecosystems and people's health. The source of microplastics is generally thought to be well known; most plastic items are not recycled or incinerated when they are discarded. Plastic waste therefore ends up in landfill or in our rivers and oceans where it gradually breaks down into smaller and smaller pieces and particles. Microplastics are defined as pieces of plastic 5mm in diameter or less. A new study however concludes that treated sewage effluents are also key sources of microplastics – the implication being that wastewater treatment plants are not effective at filtering them out. An additional reason for concern is that microplastics can also trap or act as a vehicle for the dispersal of harmful chemicals. These chemical-laced particles can be ingested by small organisms which are eaten by bigger animals and so on up the food chain.

Reference: Wastewater Treatment Plants-A Surprising Source of Microplastics Pollution, UN Environment Program (<https://www.unenvironment.org/news-and-stories/story/wastewater-treatment-plants-surprising-source-microplastic-pollution>)

3.4 Risk Assessment Approach to HCWM

The primary objective of risk assessment is to identify all potential hazards associated with HCWM from the point of generation to treatment and disposal. This would include all hazards and hazardous event that will compromise the safety of patients, health care personnel, waste handlers and the proximate community at every step of waste management. The risk is then evaluated to distinguish those highly significant from least significant in order of priority of action. The potential to affect public health and safety is the most important consideration in doing risk assessment.

Risk assessment defines the following:

- **Hazard** – A hazard is defined as a "condition, event or circumstance that could lead to or contribute to an unplanned or undesirable event." It may also be referred to as a problem. Any indicators that do not meet the target should be considered a potential hazard.
- **Risk** – A risk is the potential of a set of unwanted circumstances or events occurring as the result of the hazard. All hazards have associated risks. The risk exposure is the probability of an unfortunate event occurring, multiplied by the potential impact or damage incurred by the event.

Table 3: Example of hazards identified in HCFs (under WASH)

Hazards	Risks
<ul style="list-style-type: none"> • Waste is not correctly segregated at waste generation points. • Appropriate protective equipment for staff in charge of waste treatment and disposal is not available. 	<ul style="list-style-type: none"> • Staff, patients, visitors, and community members at risk of infection from HCW, including needle stick injuries and exposure to contaminated fluids. • Staff at risk of infection during treatment and disposal of HCW.

3.4.1 Risk Categorization

In doing risk assessment for an HCF, the recommended reference is the Water and Sanitation Health Facility Improvement Tool (WASH FIT), a risk-based approach for improving and sustaining water, sanitation, and hygiene and HCWM infrastructure and services in HCFs in low- and middle-income countries.

WASH FIT uses global standard indicators to determine potential hazards and problems in an HCF. It is an improvement tool to be used on a continuous and regular basis, to first and foremost help HCF staff and administrators prioritize and improve services, and, second, to inform broader district, regional, and national efforts to improve quality health care. The tool provides a table for recording the hazards and risks associated with each WASH area in the HCF; the level of risk versus the feasibility of addressing a problem; and the actions to be taken at the facility/community and/or district/regional.

Box 11: Overview of WASH FIT

Water and Sanitation for Health Facility Improvement Tool (WASH FIT) is a multistep, iterative process to facilitate improvements in WASH services, quality, and experience of care. It is designed for use by HCF managers and staff to make improvements in settings where resources are limited. It covers four broad areas: water, sanitation (including HCWM), hygiene (hand hygiene and environmental cleaning) and management.

Each area includes indicators and targets for achieving minimum standards for maintaining a safe and clean environment. These standards are based on global standards as set out in the WHO Essential environmental health standards in health care (WHO, 2008) and the WHO Guidelines on core components of infection prevention and control programmes at the national and acute health care facility level (WHO, 2016a).

The WASH FIT process has five (5) tasks that should be implemented sequentially. In the tool kit, each task includes a description of the steps necessary to complete the task, a list of “dos and don’ts” to consider and instructions for using the templates.

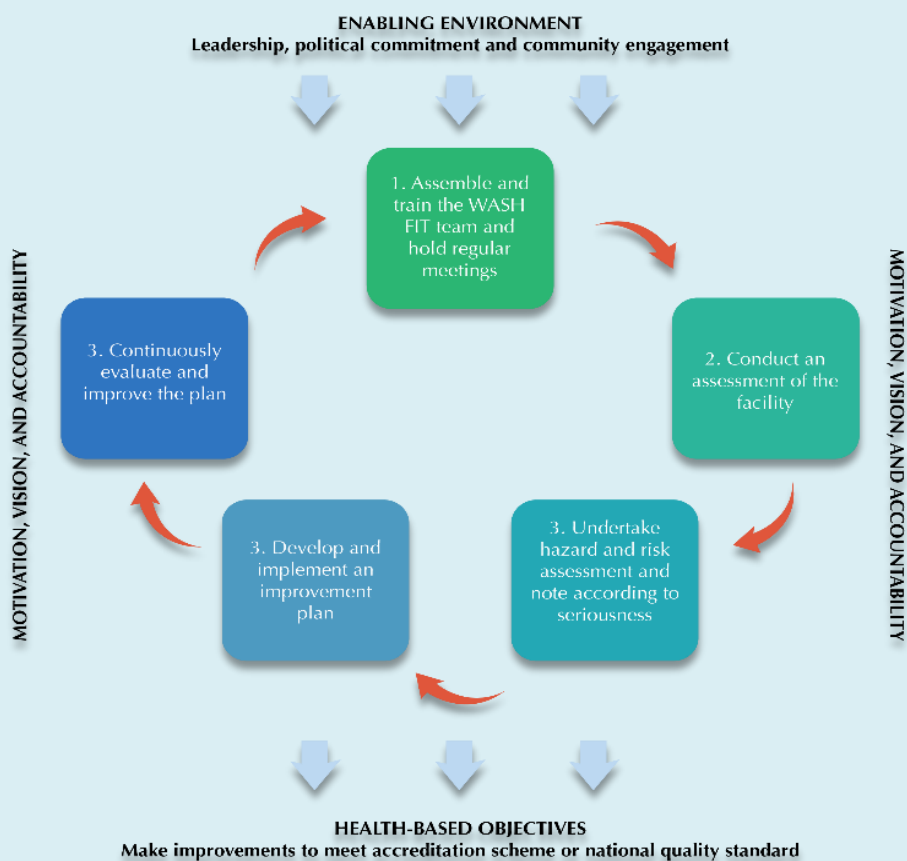

Reference: *Water and Sanitation for Health Facility Improvement Tool (WHO, 2018)*

The level of risk is categorized using the following ratings:

- **High Risk** – The hazard/problem very likely results in injuries, acute and/or chronic illness, infection, or an inability to provide essential services. Immediate actions need to be taken to minimize the risk.
- **Medium Risk** – The hazard/problem likely results in moderate health effects, discomfort, or unsatisfactory services, for example unpleasant odors, unsatisfactory working conditions, minor injuries. Once the high risks issues are addressed, actions should be taken to minimize medium-level risks.
- **Low Risk** – No major health affects anticipated. These risks should be addressed as resources become available and should be revisited in the future as part of the review process.
- **Unknown Risk** – Further information is needed to categorize the risk. Some action should be taken to reduce the risk while more information is gathered.

Some hazards may be easier to address than others depending on the resources currently available and/or the time it will take to fix a problem.

3.4.2 Improvement Plan

To prioritize which hazards/problems will be addressed and develop a detailed action plan outlining what improvements will be made within a given timeframe. The improvement plan is the “action plan” to mitigate or introduce control measures to prevent the hazard from causing harm.

The improvements could be achieved through a number of different mechanisms, including building new infrastructure or repairing existing infrastructure, coordinated dialogue with district and national authorities for new/revised infrastructure, writing standards and protocols to improve behaviors, training staff in a new technique or initiative and/or improving management methods. It is important to consider the level of difficulty or ease with which the improvements can be made.

Considerations for implementing an improvement plan:

- Do make the actions as specific as possible. Specify who is responsible for ensuring the action is completed, when it will be completed and what resources are needed. The resources could be financial, technical (such as external support specialists) or someone's time. Make sure each activity is realistically achievable with the resources and time available.
- Do think of improvements and preventive measures that can be made with limited resources. Consider, for example, ensuring that a latrine or toilet and area around it are clean, providing soap and water or alcohol-based hand rubs at all hand hygiene stations or putting up a poster with pictures and diagrams describing basic hand hygiene principles.

- Do remember that no change is too small. Whatever positive actions are taken will make a difference. For those action items that are more difficult to address (e.g., installing an on-site wastewater treatment), think of small actions that can be taken to begin the process of change (e.g., presenting a case for a new water STP to the local authorities).
- Do use the improvement plan as a basis for seeking financial or other support for larger upgrades and improvements. A detailed plan could be used to approach the government, donors, or NGOs for additional support.

Review the improvement plan to determine whether all actions are being implemented, how far along the actions are toward completion and what further steps need to be taken to ensure that the action item will be completed by the expected completion date.

4 Legislative, Regulatory, and Policy Aspects of Health Care Waste

HCFs are responsible for ensuring the proper handling, collection, transport, treatment, storage, and disposal of the HCW they generate. This chapter presents the salient points of the guiding principles and the existing international agreements, national policies, and related issuances and guidelines that can provide direction to HCFs in developing and implementing their respective HCWM programs. Links to the full text of these are provided in **ANNEX F 1** of this Manual.

4.1 Guiding Principles⁵

These principles are recognized as fundamental to effective waste management:

“POLLUTER PAYS” PRINCIPLE implies that all producers of waste are legally and financially responsible for the safe and environmentally sound disposal of the waste they produce. This principle also attempts to assign liability to the party that causes damage.

“PRECAUTIONARY” PRINCIPLE is a persuasive principle governing health and safety protection. It was defined and adopted under the Rio Declaration on Environment and Development (1992) as Principle 15: “Where there are threats of serious or irreversible damage, lack of full scientific certainty shall not be used as a reason for postponing cost-effective measures to prevent environmental degradation.”

“DUTY OF CARE” PRINCIPLE stipulates that any person handling or managing hazardous substances or wastes or related equipment is ethically responsible for using the utmost care in that task. This is best achieved when all parties involved in the production, storage, transport, treatment, and final disposal of hazardous wastes (including HCW) are appropriately registered or licensed to produce, receive, and handle named categories of waste.

“PROXIMITY” PRINCIPLE recommends that treatment and disposal of hazardous waste take place at the closest possible location to its source to minimize the risks involved in its transport. Similarly, every community should be encouraged to recycle or dispose of the waste it produces, inside its own territorial limits, unless it is unsafe to do so.

“PRIOR INFORMED CONSENT” PRINCIPLE, as embodied in various international treaties, is designed to protect public health and the environment from hazardous waste. It

⁵ Adopted from “Safe management of wastes from health-care activities” (WHO, 2014)

requires that affected communities and other stakeholders be apprised of the hazards and risks, and that their consent be obtained. In the context of HCW, the principle could apply to the transport of waste and the siting and operation of waste-treatment and disposal facilities.

4.2 International Agreements/Conventions

These international agreements/conventions are particularly relevant to HCWM.

4.2.1 The Basel Convention on the Control of Trans-boundary Movements of Hazardous Wastes and Their Disposal (1989)

The Basel Convention is a comprehensive global environmental treaty that aims to protect human health and the environment against the adverse effects resulting from the generation, management, transboundary movement, and disposal of hazardous and other wastes. Parties to the Basel Convention are obliged to ensure that hazardous and other wastes are managed and disposed of in an environmentally sound manner.

The Convention specifically refers to the following waste streams as “hazardous wastes” among other categories of wastes to be controlled: clinical wastes from medical care in hospitals, medical centers, and clinics (Y1); and waste pharmaceuticals, drugs, and medicines (Y3). Also included in the list of hazardous characteristics specified under the Convention are infectious substances defined as “substances or wastes containing viable microorganisms or their toxins which are known or suspected to cause disease in animals or humans” (H6.2).

4.2.2 The Stockholm Convention on Persistent Organic Pollutants (2001)

The Stockholm Convention is a global treaty to protect human health and the environment from persistent organic pollutants (POPs), which are chemicals that remain intact in the environment for long periods, become widely distributed geographically, accumulate in the fatty tissue of living organisms, and are toxic to both humans and wildlife.

Parties to the Stockholm Convention are enjoined to reduce or eliminate releases of POPs into the environment, including those unintentionally formed and released from waste incinerators and co-incinerators of municipal, hazardous, or medical waste or of sewage sludge, among other source categories. Governments must require the use of best available techniques (BAT) and promote best environmental practices (BEP) for new sources within four years after the Convention come into force for the country.

4.2.3 The Minamata Convention on Mercury (2013)

The Minamata Convention on Mercury has been signed in 2013 and is a global treaty to protect human health and the environment from the adverse effects of

mercury. The Convention draws attention to a global and ubiquitous metal that, while naturally occurring, has broad uses in everyday objects and is released to the atmosphere, soil, and water from a variety of sources. Controlling the anthropogenic releases of mercury throughout its lifecycle has been a key factor in shaping the obligations under the Convention. Article 4 calls for the phase-out of the import, export, and manufacture of mercury thermometers and sphygmomanometers used in health care by 2020 and the phasing down of dental amalgam.

4.2.4 World Health Assembly Resolution on Water, Sanitation and Hygiene (WASH) in Health Care Facilities (2019)

At the 2019 World Health Assembly (WHA), Member States unanimously approved a resolution to work towards universal access to WASH, including safe management of HCW in HCFs. The resolution calls upon Member States and specifically Ministries of Health to conduct national assessments and analyses, develop roadmaps, set targets, and implement standards.

4.3 National Policies and Related Issuances

These national policies and issuances are particularly relevant to HCWM.

4.3.1 Republic Act No. 4226: “Hospital Licensure Act” (1965)

The Act requires the registration and licensure of all hospitals in the country and mandates the DOH – Bureau of Medical Services (presently the Health Facilities and Services Regulatory Bureau or HFSRB), as the acting licensing agency, to set standards in hospital construction and operation. Relevant to this Act are the following administrative orders (AO):

- **DOH Administrative Order No. 2005-0029 dated December 12, 2005 “Amendment to Administrative Order No. 147 s. 2004: Amending Administrative Order No. 70-A series 2002 re: Revised Rules and Regulations Governing the Registration, Licensure and Operation of Hospitals and Other Health Facilities in the Philippines”**

The AO amends specific provisions of the preceding issuances, which require all hospitals and other health facilities, government or private, to conform with the prescribed guidelines on planning, design, construction, and management of the service capability, personnel, equipment, physical plant as part of licensing requirements. The amendment includes the requirement for hospitals and other health facilities applying for initial License to Operate to accomplish/submit a Waste Management Plan, among other documents.

- **DOH Administrative Order No. 2007-0027 dated August 22, 2007 “Revised Rules and Regulations Governing the Licensure and Regulation of Clinical Laboratories in the Philippines”**

The AO requires all clinical laboratories, government or private, to have written policies and procedures for the provision of laboratory services and for the operation and maintenance of the laboratory, including proper disposal of waste and hazardous substances, as well as biosafety and biosecurity.

- **DOH Administrative Order No. 2012-0012 dated July 18, 2012 “Rules and Regulations Governing the New Classification of Hospitals and Other Facilities in the Philippines”**

The AO promulgates rules and regulations to protect and promote the health of the public by ensuring a minimum quality of service rendered by all government and private hospitals and other regulated health facilities and to assure the safety of patients and personnel.

4.3.2 Presidential Decree No. 856: “The Code on Sanitation of the Philippines” (1975)

The Code mandates the DOH to promote and preserve public health and upgrade the standards of medical practice, among other functions and provides the other legal basis for the DOH to issue and require compliance with the HCWM Manual. Relevant to HCWM are the following implementing rules and regulations (IRR):

- **Implementing Rules and Regulations of PD 856 Chapter XVII on “Sewage Collection and Disposal, Excreta Disposal and Drainage” (1995)**

The IRR provides specific requirements in the design, construction/installation, operation, and abandonment of drainage, sewerage, sewage, and excreta disposal systems. Hospitals, clinics, and laboratories are identified among special establishments required to obtain approval from the DENR before construction and issuance of sanitary permit by the local health office. Special precaution is also advised for radioactive excreta and urine of hospitalized patients.

- **Implementing Rules and Regulations of PD 856 Chapter XXI on “Disposal of Dead Persons” (1997)**

The IRR provides specific requirements in the establishment, operation, and closure of crematories, funeral and embalming establishments, medical and research institutions, public and private burial grounds, and other similar institutions.

- **Implementing Rules and Regulations of PD 856 Chapter XVIII on “Refuse Disposal” (1998)**

The IRR provides sanitary requirements for the segregation, storage, collection, transportation, treatment/processing, and disposal of solid waste. It also specifies that management of biomedical waste produced by health care institutions and other similar establishments shall be in accordance with the DOH standards and guidelines.

- **Rules and Regulation Governing the Collection, Handling, Transport, Treatment and Disposal of Domestic Sludge and Septage, (2004), a “Supplement to the IRR of Chapter XVII on Sewage Collection and Disposal and Excreta Disposal and Drainage of 1998”**

The Rules and Regulations require individuals, firms, public and private operators, owners, and administrators engaged in desludging, collection, handling and transport, treatment, and disposal of domestic sewage treatment plants/facilities and septage from house septic tanks to secure environmental sanitation clearances from DOH.

- **DOH Administrative Order No. 2019-0047 dated October 29, 2019 “National Standard on the Design, Construction, Operation and Maintenance of Septic Tank Systems”**

The AO sets a national standard on the design, construction/installation, operation, and maintenance of septic tank as the major component of basic sanitation facilities and other alternative sanitation technology design. It applies to all public and private sewage collection system projects planned by any government agency or instrumentality including government-owned and controlled corporations, private organizations, firms, individuals, or other entities.

4.3.3 Presidential Decree No. 984: “Providing for the Revision of Republic Act No. 3931, Commonly Known as the Pollution Control Law, and for Other Purposes” (1976)

The Pollution Control Law is the primary legislation that governs discharges of potentially polluting substances to air and water. It provides the basis for the DENR regulations on water pollution through its IRR, DENR Administrative Order Nos. 34 and 35. The IRR for air emissions was initially set by DENR Administrative Order No. 14 but was later replaced by the Philippine Clean Air Act of 1999 (RA 8749).

- **DENR Administrative Order No. 2014-02 dated February 3, 2014 “Revised Guidelines for Pollution Control Officer Accreditation”**

The AO covers the accreditation of PCOs of establishments that discharge solid, liquid, or gaseous wastes to the environment or whose activities, products, or services are actual and/or potential sources of land, water, or air pollution. It also applies to LGUs, development authorities, government-owned and controlled corporations, and other public establishments.

- **DENR Administrative Order No. 2018-07 dated June 14, 2018 “Amendment of Section 7 of the DENR Administrative Order No. 2014-02 or the Revised Guidelines for Pollution Control Officer Accreditation”**

The AO requires government institutions and LGUs that operate establishments such as, but not limited to, slaughterhouses, public markets, and hospitals whose activities necessitate the appointment/designation of a PCO under the said Order to appoint/designate a PCO.

4.3.4 Presidential Decree No. 1586: “Environmental Impact Statement (EIS) System” (1978)

The law and its IRR (DENR Administrative Order No. 2003-30) require development projects, including HCFs, to undergo Environmental Impact Assessment (EIA) and secure an Environmental Compliance Certificate (ECC) from the DENR EMB prior to

construction and operation. An ECC is likewise required for the installation or construction and operation of HCW treatment systems (e.g., pyrolysis, autoclave, microwave) and disposal facilities (i.e., sanitary landfill).

4.3.5 Republic Act No. 6969: “Toxic Substances and Hazardous and Nuclear Wastes Control Act of 1990”

The law and its IRR (DENR Administrative Order No. 1992-29) require the registration of waste generators, waste transporters and operators of toxic and hazardous waste treatment facilities with the EMB. The waste generators are required to ensure that its hazardous wastes are properly collected, transported, treated, and disposed of to a sanitary landfill. In support of this Act are the following issuances:

- **DENR Administrative Order No. 36, Series of 2004, dated August 31, 2004 “Revising DENR Administrative Order No. 29, Series of 1992, to Further Strengthen the Implementation of Republic Act 6969 (Toxic Substances and Hazardous and Nuclear Wastes Control Act of 1990) and Prescribing the Use of the Procedural Manual”**

The Procedural Manual requires a comprehensive documentation on the legal and technical requirements of hazardous waste management. The Manual does not include provisions regarding the management of nuclear wastes. It is composed of ten sections that discuss the classification of hazardous wastes, waste generators and transporters, storage and labelling, Treatment, Storage and Disposal (TSD) facilities, manifest system, monitoring, prohibited acts and schedule of fees.

- **Joint DENR-DOH Administrative Order No. 02, Series of 2005, dated August 24, 2005 “Policies and Guidelines on effective and proper handling, collection, transport, treatment, storage and disposal of health care wastes”**

The Joint Administrative Order aims to: a) provide guidelines to generators, transporters and operators/owners of TSD Facilities on proper handling, collection, transport, storage, treatment and disposal of HCW; b) clarify the jurisdiction, authority and responsibility of the DENR and DOH with regard to HCWM; and c) harmonize the efforts of the DENR and the DOH on HCWM.

- **DOH Administrative Order No. 2008-0021 dated July 30, 2008 “Gradual Phase-out of Mercury in all Philippine Health Care Facilities and Institutions”**

The AO requires all HCFs to gradually phase out the use of mercury containing devices and equipment. The initial targets of the phase-out are mercury thermometers and sphygmomanometers in the HCF.

- **DENR Administrative Order No. 2013-22 dated December 4, 2013 “Revised Procedures and Standards for the Management of Hazardous Wastes (Revising DAO 2004-36)”**

The AO seeks to ensure the important aspects of the Title III of DAO 1992-29, particularly the requirements for hazardous waste generators, transporters, and treaters are developed and presented in a useful information/reference document

for various stakeholders; and to further streamline procedures for generation and compliance to the legal and technical requirements for hazardous waste management in the light of recent development.

4.3.6 Republic Act No. 8749: “The Philippine Clean Air Act of 1999”

The law promotes the use of state-of-the-art, environmentally sound, and safe thermal and non-burn technologies for the handling, treatment, thermal destruction, utilization, and disposal of sorted biomedical and hazardous wastes. It prohibits incineration, defined as the burning of municipal, biomedical, and hazardous wastes, which process emits toxic and poisonous fumes.

- **DENR Administrative Order No. 2000-81 dated November 7, 2000 “Implementing Rules and Regulations of the Philippine Clean Air Act of 1999”**

The IRR provides guidelines on the operationalization of RA 8749, including national ambient air quality guideline values, national emission standards for source specific air pollutants, and emission standards for treatment facilities using non-burn technologies.

4.3.7 Republic Act No. 9003: “Ecological Solid Waste Management Act of 2000”

The law seeks to ensure the protection of public health and the environment through the utilization of environmentally sound methods for treating, handling, and disposing of solid wastes, and encourages waste minimization and segregation at the point of generation, including households and institutions such as hospitals.

- **DENR Administrative Order No. 2001-34 dated December 20, 2001 “Implementing Rules and Regulations of the Philippine Ecological Solid Waste Management Act of 2000”**

The IRR prescribes procedures and guidelines to facilitate the implementation of and compliance to RA 9003, including the minimum requirements and standards for volume reduction, segregation, storage, collection, transport, and handling of solid wastes; provisions on materials recovery, composting, and implementing recycling programs; as well as minimum considerations for siting, designing and operating sanitary landfills.

4.3.8 Republic Act No. 9275: “The Philippine Clean Water Act of 2004”

The law pursues a policy of economic growth in a manner consistent with the protection, preservation, and revival of the quality of the country's fresh, brackish, and marine waters.

- **DENR Administrative Order No. 2005-10 dated May 16, 2005 “Implementing Rules and Regulations of the Philippine Clean Water Act of 2004”**

The IRR contains provisions for the development and establishment of industry-specific, technology-based standards that limit the amount of industrial wastewater pollutants being discharged into waters either directly to surface waters or indirectly

through existing sewerage and treatment systems. It also requires owners or operators of facilities that discharge regulated effluents to secure a wastewater discharge permit.

- **DENR Administrative Order No. 2016-08 dated May 24, 2016 “Water Quality Guidelines and General Effluent Standards of 2016”**

The AO provides, among others, guidelines for the classification of water bodies in the country and the General Effluent Standards (GES) for all point sources of pollution, regardless of volume and industry category.

4.3.9 Republic Act No. 11223: “Universal Health Care Act”

The law and its IRR aims to progressively realize universal health care in the country through a systemic approach and clear delineation of roles of key agencies and stakeholders towards better performance in the health system and to ensure that all Filipinos are guaranteed equitable access to quality and affordable health care goods and services and protected against financial risk. Among the provisions in this Act is the strengthening of the capacity of PhilHealth and DOH to monitor and regulate health facilities. An incentive scheme shall be provided by PhilHealth to reward health facilities that provide better service quality, efficiency, and equity, among these shall be proper management of HCW.

4.4 Other Relevant Issuances and Guidelines

- **BFAD Bureau Circular No. 16, Series of 1999, dated January 6, 1999 “Amending BFAD MC #22 dated September 8, 1994 regarding Inventory, Proper Disposal and/or Destruction of Used Vials or Bottles”**

This issuance amends BFAD Memorandum Circular No. 22, Series of 1994, which provides guidelines on the proper inventory and destruction of bottles and vials to prevent the proliferation of adulterated, misbranded, and counterfeit drugs brought about by the recycling of used pharmaceutical bottles and vials.

- **Executive Order No. 301, Series of 2004, dated March 29, 2004 “Establishing a Green Procurement Program for All Departments, Bureau, Offices and Agencies of the Executive Branch of Government”**

The Green Procurement Program (GPP) was implemented in all government offices in order to a) promote the culture of making environmentally-informed decisions in government, especially in the purchases and use of different products; b) include environmental criteria in public tenders, whenever possible and practicable; c) establish the specifications and requirements for products or services to be considered environmentally advantageous; and d) develop incentive programs for suppliers of environmentally advantageous products or services.

- **PhilHealth Benchbook for Quality Assurance in Health Care (2006)**

The PhilHealth Benchbook included HCWM as one of its parameters in the quality assurance of health care.

- **DOH Administrative Order No. 2008-0023 dated July 30, 2008 “National Policy on Patient Safety”**

The AO requires the establishment and maintenance of a culture of patient safety in every HCF as the responsibility of its leadership. As such, each HCF shall ensure that an enabling mechanism/strategy is in place to ensure patient safety. The key priority areas in patient safety include but are not limited to proper patient identification, assurance of blood safety, safe clinical and surgical procedures, provision and maintenance of safe quality drugs and technology, strengthening infection control standards, maintenance of the environment of care standards and energy and waste management standards.

- **DOH “Operation Manual on the Rules and Regulations Governing Domestic Sludge and Septage” (2008)**

The Manual provides detailed procedures and forms needed to comply with the IRR Governing Collection, Handling, Transport, Treatment and Disposal of Domestic Sludge and Septage. It is designed to guide private and public service providers as well as government regulators to effective sludge and septage management program in the country.

- **WHO “Safe management of wastes from health-care activities” (2014)**

This document is the second edition of the WHO handbook on the safe, sustainable, and affordable management of HCW—commonly known as “the Blue Book”. It is a comprehensive publication used widely in health care centers and government agencies to assist in the adoption of national guidance. It is intended to provide support to committed medical directors and managers to make improvements and presented practical information on waste management techniques for medical staff, waste workers, regulators, policymakers, development organizations, voluntary groups, environmental bodies, environmental health practitioners, advisers, researchers, students, and other individuals and organizations with an active interest in the safe management of HCW.

- **WHO “Water Sanitation for Health Facility Improvement Tool (WASH FIT)” (2018)**

As described in **Chapter 3.4**, WASH FIT is a risk-based approach for improving and sustaining water, sanitation, and hygiene and HCWM infrastructure and services in HCFs in low- and middle-income countries. It is an improvement tool to be used on a continuous and regular basis, to first and foremost help HCF staff and administrators prioritize and improve services, and, second, to inform broader district, regional and national efforts to improve quality health care. WASH in HCFs is a fundamental prerequisite for achieving national and global health goals. Safe water, functioning

hand washing facilities, latrines, and hygiene and cleaning practices are especially important for improving health outcomes linked to maternal, newborn and child health, as well as carrying out basic infection prevention and control procedures necessary to prevent antimicrobial resistance (AMR).

- **WHO “Overview of technologies for the treatment of infectious and sharp waste from health care facilities” (2019)**

The document aims to: 1) provide criteria for selecting technologies to facilitate decision making for improved management of waste in HCFs; and 2) provide an overview of specific HCW technologies for the treatment of solid infectious and sharp waste for HCF administrators and planners, WASH and infection prevention control staff, national planners, donors and partners. For each technology, details on its operation, effects on the environment and health, requirements for installation, capacities for treating waste, examples of consumables and advantages and disadvantages are described.



**BIOHAZARDOUS WASTE
STORAGE AREA**

**PART II – HEALTH CARE
WASTE MANAGEMENT SYSTEM**

5 Health Care Waste Management Planning

Wastes generated at the HCFs may pose harm and risks to the health care workers and communities if not properly managed. Health care waste management (HCWM) is a process that helps in ensuring the proper management of HCW from the point of generation to until disposal.

Figure 3: Seven important points in waste management



HCWM operation must be organized and planned and will vary depending on the type of wastes being handled. Planning defines the strategy for the implementation of improved waste management and the allocation of roles, responsibilities, and resources. A well-thought-out plan describes the actions to be implemented by authorities, health care personnel and waste workers.

Box 12: Objectives of HCWM Planning

HCWM planning should cover the **six objectives** listed below:

- Develop the legal and regulatory framework for HCWM.
- Rationalize the waste management practices within HCFs.
- Develop specific financial investment and operational resources dedicated to waste management.
- Launch capacity building and training measures.
- Set up a monitoring plan.
- Reduce the pollution associated with waste management.

Source: WHO; Basel Convention, UNEP (2005)

The HCWM Plan should include all the aspects of managing wastes, from waste avoidance and minimization, proper segregation and containment, safe handling, storage and transport until treatment and disposal. It should also provide a clear definition of the roles and responsibilities of the staff that are involved in HCWM. Requirements for training and awareness should also be listed in the plan.

Legal requirements should be referenced to ensure the compliance of the facility

to the national standards. The allocation of resources needed should be set out in terms of finances, time, equipment, and personnel. As HCWM is an evolving field, the planning process should allow for periodic updates to policies as improvements in processes and technology become known.

Box 13: Planning according to facility size



Hospitals should aim to establish a formal waste management plan. This is a document that contains the combined knowledge and decisions for all involved in the production, handling and treatment of wastes. A senior person at the HCF should be chosen and made responsible for preparing the plan, collecting ideas from others and, once agreed, promoting the way HCW should be managed to medical and ancillary staff.

At a primary care facility, the local plan would be a shorter description of the waste management arrangements that should be put in place in each medical area, as well as identifying who is responsible for good practices in each area, where the waste will go, and how it should be disposed of after it has been removed by a cleaner or porter.

5.1 Organization and Functions

The success of the implementation of the HCWM Plan is completely dependent on the commitment of the entire staff of the HCF. The entire organization of the HCF must be responsible for the proper segregation, collection, storage, treatment, and disposal of waste generated by the facility. However, there are certain units and individuals in the HCF that usually have more responsibilities relative to HCWM.

The Office of the Administrator and/or Head of the HCF shall oversee the implementation of the HCWM Plan. The duties and responsibilities of the Head of the HCF in relation to the HCWM Plan are as follows:

- Organize a HCWM Committee that is fully represented by all medical, nursing, and administrative services in the HCF to develop and implement a written HCWM Plan;
- Appoint/designate a Waste Management Officer (WMO) or its equivalent Pollution Control Officer (PCO) to supervise and coordinate the HCWM planning and its subsequent implementation;
- Conduct periodic review and update the HCWM Plan and incorporate monitoring procedures;
- Allocate sufficient financial and personnel resources to ensure effective and efficient implementation of the HCWM Plan;

- Appoint/designate alternative members in the event of personnel leaving key positions in the HCWM Committee or temporarily assign responsibility to another staff member until another one can be formally appointed/designated;
- Provide adequate training for key members and designate the staff responsible for coordinating and implementing training courses;
- Provide speedy resolution of complaints and other related legal matters; and
- Maintain good working relationship with other related agencies by proper referral, consultation, and cooperation concerning HCWM

5.2 Health Care Waste Management Committee

Appointment or designation of specific committee to handle HCWM in the HCF is critical on the part of the Administrator or Head of the facility. The qualification and political will of the person to be designated would determine the success of the program. The HCWM Committee shall be responsible for the following functions:

- Formulate a policy formalizing the HCF commitment to properly manage its waste with the goal of protecting health and the environment;
- Establish baseline data and develop the HCWM Plan, which shall include a minimization plan, training, and written guidelines on waste management;
- Implement the HCWM Plan; review and update the policy, plans, and guidelines on an annual basis;
- Ensure adequate financial and human resources for HCWM Plan implementation;
- Conduct regular committee meeting and submit minutes of meeting;
- Regularly monitor and evaluate the HCWM Plan efficiency and effectiveness; and
- Ensure strict compliance with existing laws, policies, and guidelines.

The composition and structure of the HCWM Committee depends on the needs and capacities of the HCF. The specific duties and functions of the HCWM Committee members are described in **ANNEX B 1**.

- In hospitals where large quantities of waste are generated, a separate HCWM Committee is required to be formed. (see **Box 14**)
- In primary care facilities with limited staff, the suggested approach is to set up a Waste Management Team or have a smaller Infection Control Committee with one person responsible for HCWM or at least an

appointed WMO. At the minimum, the team should include the head of the facility, physicians, nurses, and the general services.

- In an institution that is not directly involved in patient care, such as a medical research institution, the head of the establishment should use their discretion to appoint members of the Waste Management Team from among the relevant staff.

Box 14: HCWM Committee for hospitals

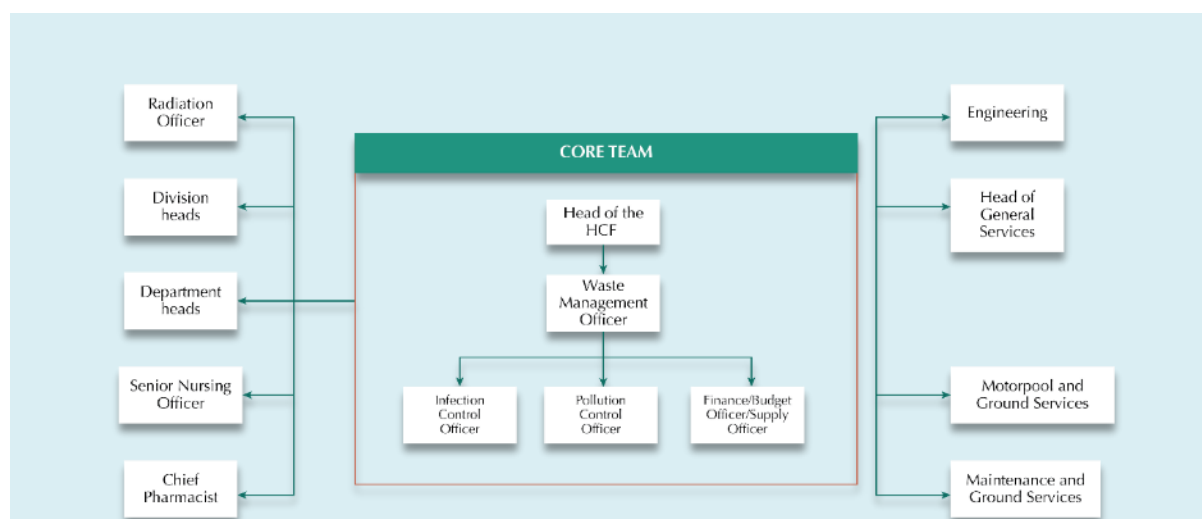

Core Team

In hospitals, the HCWM Committee shall be composed of at least a minimum of five (5) members as the Core Team, to be composed of: (1) Head/Administrator of the HCF as chairperson; (2) Waste Management Officer; (3) Infection Control Officer; (4) Pollution Control Officer, and (5) Finance/Budget Officer/Supply Officer.

The Core Team shall be responsible for the following duties and responsibilities:

- Organize and establish the HCWM sub-committees or group who will directly implement within specific units of the HCF the HCWM policies and guidelines;
- Prepare the budgetary plan for the logistic requirements to implement HCWM within the HCF;
- Formulate policies and guidelines in the implementation of HCWM including granting of incentives for best practices;
- Approve request for unit activities and programs which will include training;
- Provide assistance to all units relative to proper orientation of all staff; and
- Document and prepare report on regular basis.

Members

Key staff of the HCF should also be part of the HCWM Committee, such as the department heads, division heads, senior nursing officer, chief pharmacist, radiation officer, head of the general services, maintenance and ground services, motor pool services, and the HCF engineer.

5.3 Health Care Waste Management Plan

A comprehensive HCWM Plan is the key ingredient to a successful waste management within an HCF. It is important that the plan be understood or followed

to be of great value to the organization.

5.3.1 Development of the HCWM Plan

The following shall be addressed in developing a comprehensive HCWM Plan:

A. Assessment of waste generation and waste disposal

In developing a HCWM Plan, the HCWM Committee needs to assess all waste generated in the HCF. The Waste Management Team should take special care to test the robustness of the Plan during periods of “peak” waste production. The Plan should also consider potential slack periods or other unusual circumstances that may significantly reduce waste quantities.

Surveys can be used to help plan for these periods of higher or lower waste generation; for example, survey results can sometimes be used to predict future changes in hospital capacity or the establishment of new departments. The WMO shall be responsible for coordinating such a survey and for the analysis of the results. The assessment shall include the following: average daily volume of waste generated per category within a given period (refer); site and location of the HCF vis-à-vis the existence of accredited TSD within the locality; and assessment of any future changes in the facility, departmental growth, or the establishment of new departments.

Refer to **ANNEX D 1** for a sample HCWM assessment checklist for primary care facilities and to **ANNEX D 2** for a sample sheet for waste generation assessment. Data from the waste generation survey shall be a basis of the HCWM Plan.

B. Review of existing HCWM policies and procedures being implemented

During HCWM Plan development, every member of the HCWM Committee should review existing HCWM arrangements in their area of responsibility. Existing practices should then be evaluated in the light of national guidelines and recommendations made to the WMO on how the guidelines can be implemented in each area. The following activities must be done in developing the HCWM Plan:

- Understanding of existing policies, laws, and regulations related to HCWM;
- Review and evaluation of present HCWM system to include where and what types of waste are being generated, how and where waste is stored, treated, and disposed, and the cost effectiveness of the current handling processes, including purchase and product utilization practices;
- Possibilities for waste minimization, reuse, and recycling; segregation; on-site handling, transport, and storage practices;
- Identification and evaluation of recordkeeping/documentation, training, and monitoring options;
- Estimation of costs relating to HCWM, including capital, operational, and

maintenance costs;

- Strategy for implementing the Plan, and;
- Revision/redesigning of the Plan to ensure all issues have been addressed.

C. Formulation and drafting of HCWM Plan

The following may be used as guide in drafting and formulating the HCWM Plan:

- 1) Short description of the HCF – This will include the background of the HCF including its mandates, type of clients being served, demographic profile and geographic location of the HCF. This will also discuss briefly the different national, local, and international laws, policies, and issuances relevant to the implementation of HCWM within the HCF.
- 2) Objective and rationale of the HCWM Plan – This will briefly discuss the purpose of the plan, targets, its coverage, scope, and limitations.
- 3) Composition of HCWM Committee – its structure, duties, and responsibilities; roles and responsibilities of the other staff of the HCF.
- 4) HCWM Plan – From point of waste generation up to final disposal including flow chart, route plans, and schedules. This will also identify the different activities and persons responsible for handling specific activities and whom to be responsible for. This will also include the milestones or strategies to move the current HCWM system into the system envisioned in the HCWM Plan, the minimization plan, the procurement plan, and others.
- 5) Information, Education, and Communication (IEC) and training activities – A comprehensive training and orientation of HCF worker shall be conducted. Each HCF staff must know their specific roles in the effective implementation of the HCWM Plan. Every HCF worker must be aware of the policy, significant health and environmental impacts of their work activities, their roles and responsibilities, procedures that apply to their work, and importance of conforming with requirements as well as consequences of not non-compliance. The HCWM Plan will identify the timetable and responsible persons for the development of training materials and conduct training for different HCF categories, development of advocacy materials (if needed), and conduct of orientation for patients and watchers.
- 6) HCF worker protection and safety – This will include the plans for HCF worker's occupational health and safety program including emergency management for possible related risks or accidents during the process. This will also indicate the infection control policies and procedures to be observed in handling HCW, specifically infectious and mercury waste.
- 7) Monitoring and evaluation – Action plan for the conduct of regular

monitoring of implementation and submission of required reports, including self-monitoring tools, assessment of findings, submission of recommendations, and status follow-up.

- 8) Financial requirements for the HCWM Plan implementation – Without specific financial resources, it is impossible to get sustainable improvements in HCWM, which is an integral part of health care and thus needs to be budgeted for.
- 9) Provision for feedback mechanism, updating, and revision of the HCWM Plan – The HCWM Committee should review the HCWM Plan annually and initiate changes necessary to upgrade the system.

Box 15: Details to include in the HCWM Plan

Location and organization of collection and storage facilities

- Drawings of the establishment showing designated bag/disposal container for every ward and department; disposal container shall be appropriately designated for HCW or other waste.
- Drawings showing the central storage site for HCW and the separate site for other waste. Details of the type of containers, security equipment, and arrangements for washing and disinfecting waste collection trolleys/carts (or other transport devices) should be specified. The document should also address eventual needs for refrigerated storage facilities.
- Drawings showing the individual waste collection routes within the HCF.
- Collection timetable for each trolley route, type of waste to be collected, and number of wards and departments to be visited on one round. The central storage point in the facility for that particular waste should be identified.

Design specifications

- Drawings showing the type of bag holder to be used in the wards and departments.
- Drawings showing the type of trolley or wheeled container to be used for bag collection.
- Drawings of sharps containers, with their specification.

Required material and human resources

- An estimate of the number and cost of bag holders and collection trolleys.
- An estimate of the number of sharps containers and HCW drum containers required annually, categorized into different sizes, if appropriate.
- An estimate of the number and cost of color-coded bags or bins to be used annually.
- An estimate of the number of personnel required for waste collection.

Responsibilities

- Definitions of responsibilities, duties, and codes of practice for each of the different categories of personnel of the hospital who, through their daily work, will generate waste and be involved in the segregation, storage, and handling of the waste.
- Definition of the responsibilities of hospital attendants and ancillary staff in collecting and handling wastes, for each ward and department; where special practices are required (e.g., for radioactive waste or hazardous chemical waste), the stage at which attendants or ancillary staff become involved in waste handling shall be clearly defined.

Procedures and practices

- Simple diagram (flowchart) showing procedure for waste segregation.
- Procedures for segregation, storage, handling of wastes requiring special arrangements, such as autoclaving.
- Outline of monitoring procedures for waste categories and their destination.
- Contingency plans, containing instructions on storage or evacuation of HCW in case of

breakdown of the treatment unit or during closure for planned maintenance.

- *Emergency procedures.*

Training

- *Description of the training courses and programs to be set up and the personnel who should participate in each.*

5.3.2 Implementation of the HCWM Plan

The head of the HCF is responsible for the HCWM Plan implementation, which involves the following steps:

- 1) Development of interim measures, as precursor to complete implementation of the new HCWM system, in collaboration with the HCWM Committee, and be appended to the plan;
- 2) Inclusion of provision on future expansion of HCF/waste storage facilities;
- 3) Appointment of personnel responsible for HCWM. Notice of this appointment should be widely circulated and updates be issued when changes occur; and
- 4) Organization and supervision of training programs for all staff, by ICO in collaboration with the WMO and other members of the HCWM Committee.

As soon steps 1 to 4 have been completed and the necessary equipment for waste management is available, the operations described in the HCWM Plan can be put into practice. The approach and recommendations in a HCWM Plan should be implemented incrementally, through gradual improvements. It is important for public authorities and managers of HCFs to be fully aware of the infection control reasons for having proper waste management procedures. The HCWM Committee should review the HCWM Plan annually and initiate changes necessary to upgrade the system. Interim revisions may also be made as and when necessary. These revisions should be documented at the time and added as an appendix to the HCWM Plan; they should be incorporated into the full plan when it is reviewed. The HCWM Committee should also update policies and practices as new national guidance becomes available.

Figure 4: Basic elements for safe HCWM in primary care facilities

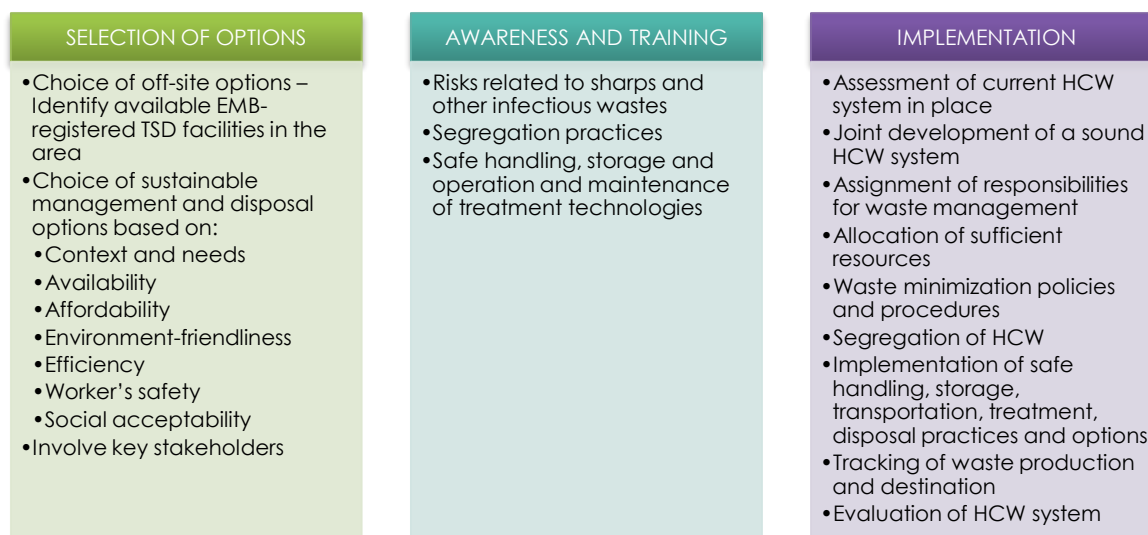

Source: Management of Solid Health Care Waste at Primary Health Care Centres (WHO, 2005)

6 Health Care Waste Minimization

The HCW generated within the HCF follows an appropriate and well identified stream from point of generation until their final disposal, that is composed of several steps that includes waste generation, segregation, collection, transportation (on-site and off-site), storage, treatment, and disposal. To illustrate, **Figure 5** summarizes the HCW handling – the flow of waste from point of generation up to its final disposition.

Figure 5: HCW handling

Step	Location/Area	HCWM Process/Step	Key Points
0	Procurement		Green Procurement Policy, stock management, Life Cycle Analysis (LCA), resource development (3Rs)
1	At source/ point of generation (all HCF units)	Generation	Color coded garbage bins/liners. Proper waste segregation
2		Segregation at source	One of the most important step to reduce risks and amount of hazardous waste generated
3	Within HCFW	On-site collection and transport	PPEs, dedicated collection bins (color-coded), easy to wash and dedicated trolleys
4		On-site storage	Central HCW storage, lockable, easy to clean, compliant with standards
5		On-site treatment and disposal	Adequate space, availability of acceptable treatment/disposal methods within the HCF
6	Outside HCF	Off-site transport	DENR accredited TSD, appropriate vehicle, HCF is informed about final destination
7		Off-site treatment and disposal	DENR accredited TSD, Sanitary Landfill. Appropriate vehicle and duly signed consignment note. Ensure proper waste treatment and disposal

Reference: Health Care Waste Management Manual, 3rd Edition (DOH, 2011)

Protecting public health through the management of wastes can be achieved by variety of methods. As mentioned in **Chapter 1.6**, these can be summarized in order of preference called the “waste management hierarchy” (**Figure 6**), with the most desirable method at the top to the least desirable at the base. “Desirability” is defined in terms of the overall benefit of each method from its particular impacts on the environment, protection of public health, financial affordability and social acceptability.

Figure 6: Waste management hierarchy

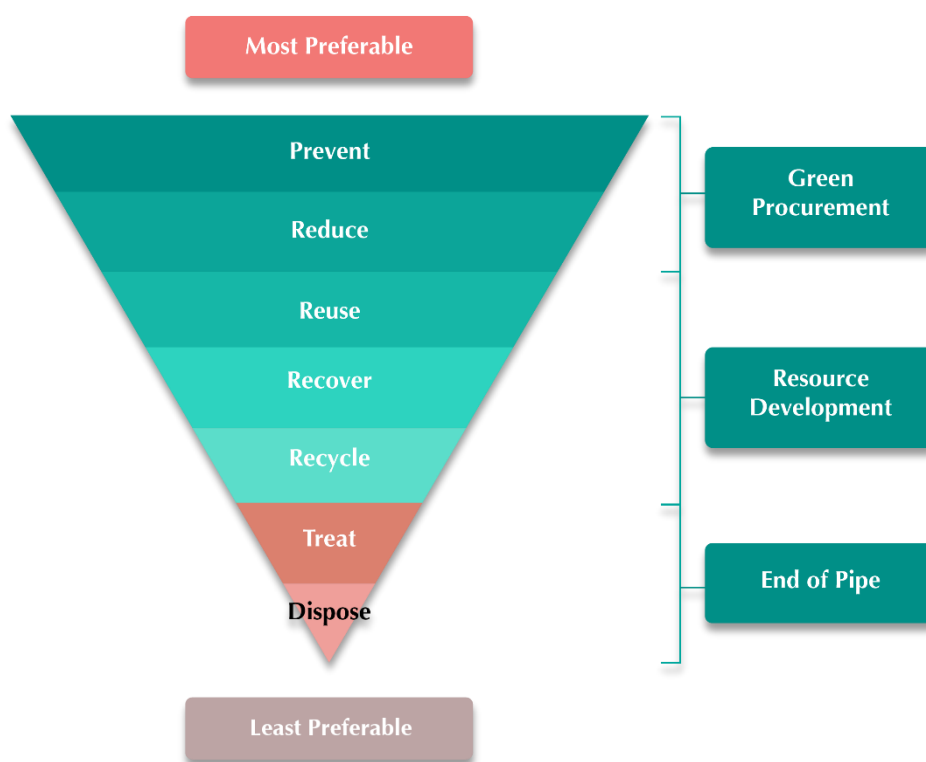

Source: Health Care Waste Management Manual, 3rd Edition (DOH, 2011)

As illustrated, the most preferable approach is to avoid producing waste as far as possible and thus minimize the quantity entering the waste stream. Where practicable, recovering waste items for secondary use is the next most preferable method.

Waste that cannot be recovered must then be dealt with by the least preferable options, such as treatment or land disposal, to reduce its health and environmental impacts.

In addressing HCWM, waste minimization basically utilizes the first two elements that could help reduce the bulk of HCW for disposal; so, the best waste management practice aims to address the problem at source rather than the end-of-pipe solution.

6.1 Principles

The underlying principle of Waste Minimization is rooted in the Hierarchy of Controls, that prevention is very important, thus before producing waste; the HCF shall investigate whether the amount of waste to be generated from the daily operation of the HCF could be minimized in order to reduce the efforts in subsequent handling, treatment, and disposal operations. The critical point in minimizing waste starts from the planning stage of the preparation of the Annual Procurement Plan (APP), which includes the list of items required for HCF activities. The management of HCF must adopt the following strategies to implement waste minimization:

- Establish an updated database for the waste generation rates, current hazardous waste management strategies and current waste management costs;
- Institutionalize waste minimization and sustain the program in the long run;
- Have a written policy with established vision and mission to implement Waste Minimization Program (WMP);
- Be aware of their specific role in HCWM and be properly trained in waste minimization; and
- Adopt the Green Procurement Policy (GPP) pursuant to Executive Order No. 301, Series of 2009.

Box 16: Examples of practices to encourage waste minimization

Source reduction

- *Purchasing reductions: selecting supplies that are less wasteful where smaller quantities can be used, or that produce a less hazardous waste product;*
- *Use of physical rather than chemical cleaning methods (e.g., steam disinfection instead of chemical disinfection);*
- *Prevention of wastage of products (e.g., in nursing and cleaning activities);*

Management and control measures at HCF level

- *Centralized purchasing of hazardous chemicals;*
- *Monitoring of chemical use within the health center from delivery to disposal as hazardous wastes.*

Stock management of pharmaceutical products

- *More frequent ordering of relatively small quantities rather than large amounts at one time, to reduce the quantities used (particularly applicable to unstable products).*
- *Use of the oldest batch of a product first.*
- *Use of all the contents of each container.*
- *Checking of the expiry date of all products at the time of delivery, and refusal to accept short-dated items from a supplier.*

Management of chemical products

- *Use of less toxic and environmentally friendly chemicals;*
- *Use minimum concentrations where possible;*
- *Ensuring good inventory control (i.e., "just-in time" purchasing);*
- *Integrating pest management*

If waste minimization is to be undertaken by the HCF, it is important to develop a good baseline data of the amount of waste generated prior to implementation of the waste minimization program. HCW generation data from the various units of the HCF shall be properly recorded on a chart with the amount of waste displayed in descending order. This method can be used to determine the highest waste generating areas where the minimization strategies shall first be initiated. This information shall be displayed and communicated throughout the HCF. The waste minimization strategy shall be formally approved in writing by top management within the HCF as a demonstration of their support and commitment to the program.

Waste minimization is beneficial not just to the waste-receiving environment but to the waste generators also. The cost for both the purchase of goods and waste treatment and disposal are reduced and the liabilities associated with the disposal of HCW is lessened. All employees have a role to play in this process and should be trained in waste minimization. This is particularly important for the staff of departments that generate large quantities of hazardous HCW. Encouraging staff to extend waste minimization requires the adoption of more rigorous methods and disciplines. Waste minimization targets can be established for each area of medical or support activities, and people can be made more personally responsible for waste minimization – possibly by providing incentives for those people and departments who are successful in achieving their targets. Educating staff to use medical materials carefully to avoid generating unnecessary waste is a further simple measure that can be undertaken.

6.2 Benefits of Waste Minimization

Institutionalization of Waste Minimization Program will enhance the HCF as to:

- Financial—Cost savings through effective waste management and more efficient use of natural resources (electricity, water, gas, and fuels); Additional income generated from sale of recyclable waste; Fines and penalties are avoided in meeting environmental legislation by identifying environmental risks and addressing weaknesses; Reduction of insurance and health costs by demonstrating better risk management.
- Operational and Internal—Improved overall performance and efficiency; Compliance with the PHIC Bench book Performance Indicator.
- External—Better public perception of the HCF; Reduction of the adverse environmental impact (i.e., land, air, and water pollution); Promoting environmental sustainability.

6.3 Waste Minimization Techniques

Waste minimization can be done in two points of the HCW handling. Best practice waste management will aim to avoid or recover as much of the waste as possible in or around an HCF, rather than disposing of it by burning or burial. This is sometimes described as tackling waste “at source” rather than adopting “end-of-pipe” solutions.

Waste can be minimized during procurement of materials needed by the HCF (Step 0). By purchasing environmentally friendly products, one can already minimize the amount of waste to be generated. To achieve lasting waste reduction (or minimization), focus should be on working with medical staff to change clinical practices to ones that use less materials. Although waste minimization is most commonly applied at the point of its generation, health care managers can also take measures to reduce the production of waste through adapting their purchasing and stock control strategies. Suppliers of chemicals and pharmaceuticals can also become responsible partners in waste minimization program. The HCF can encourage this by ordering only from suppliers who provide rapid delivery of small orders, who accept the return of unopened stock, and who offer off-site waste management facilities for hazardous wastes.

Waste can also be minimized through segregation. In this process, the 3R's principle is applied, effectively reducing the amount of waste to be treated or collected.

Figure 7: Waste minimization techniques

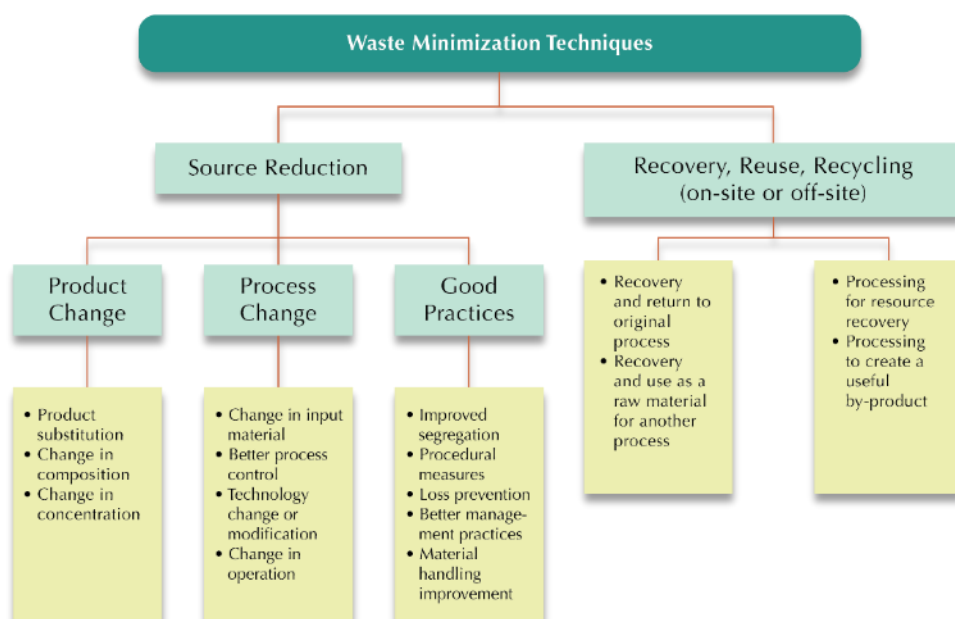

6.3.1 Green Procurement: Waste Prevention and Reduction at Source

Waste can be minimized in an HCF through proper procurement planning. The HCF can adopt the Green Procurement Program (GPP) wherein the process of procurement considers the environmental impact of items/goods/services. Addressing the issue of HCW at the source is more economically and environmentally beneficial than looking into the perennial issue of waste management disposal.

Box 17: Factors to consider in Green Procurement

Some factors to consider in green procurement are as follows:

- Less toxic
- Minimally polluting
- Energy efficient
- Safer and healthier for patients, workers, and the environment
- Higher recyclability and recycled content

Source: Philippine Health Center, Initiative on Green Procurement

6.3.1.1 Waste prevention through the adoption of GPP pursuant to Executive Order No. 2004-31

GPP urges HCFs to buy less-polluting products from a less polluting supplier. The objectives of such program are to create awareness of environmental impact, develop guidelines for green procurement, rethink material requirements and consumption, reduce the use of hazardous materials, improving energy efficiency of purchased materials, and use recycled materials and recycling of waste.

An HCF can consider some of the following approaches as part of its GPP strategy:

- Supplier Focus—through the supplier registration form with emphasis on environmental performance of supplier;
- Product and Service Focus—including environmental specifications; and
- Life Cycle Analysis—internal analyses/using LCA completed by external groups. (see **Box 18**)

In the GPP, the production of goods is required to have less environmental impact to avoid environmental contamination and harm to human health. Thus, every HCF will only procure goods from companies that fulfilled the following requirements:

- Producing goods that do not contain any substance included in the EMB-DENR list of banned substances;
- Establishing a complete elimination program for banned substances; and
- Making a commitment to sustain the program.

Box 18: Life Cycle Analysis (LCA) Tool

Using the *Life Cycle Analysis (LCA)* tool, the administrators of the HCF will be able to decide which product or service will be most suitable or applicable for its operations. LCA is a compilation and evaluation of the input, output and potential environmental impacts of a product or system throughout its life cycle.

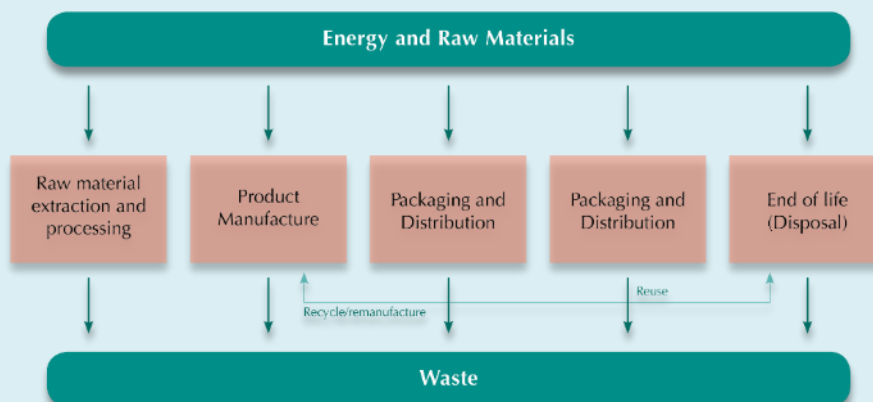

The goal of LCA is to compare the full range of environmental damages assignable to products and services. Following this assessment, businesses can identify the most effective improvement that they can make in terms of environmental impacts and use of resources.

LCA can also be used for comparing the environmental credentials of similar products and services to be able to choose the least burdensome ones. For each stage, the impact is measured in terms of resource use and environmental impacts.

Reference: *Safe Management of Wastes from Health-Care Activities, 2nd Edition (WHO, 2014)*

In order to ensure the effective implementation of this program, the HCF may review and assess its existing procurement policies and practices in order to evaluate where the major environmental impacts lie. Methods can then be sought to integrate environmental considerations into its purchasing practices.

The HCF can introduce measures to increase the utilization of recycled materials and the purchase of more environment-friendly equipment and those with green designs. These can be designed to fit with existing procurement methods, and to act as a support tool for the purchasing staff. The policy, procedures and practices shall not be designed to prohibit the purchase of any goods but merely to favor goods that are environmentally friendly. Other factors such as the quality, price, delivery time, etc. remain paramount in purchasing decisions.

6.3.12 Waste reduction at source through proper segregation of waste

Segregation is an important step in HCWM for the following reasons:

- Segregation minimizes the amount of waste that needs to be managed as hazardous waste (since mixing non-hazardous waste with hazardous waste renders the combined waste as hazardous).
- Segregation facilitates waste minimization by generating a solid waste

stream which can be easily, safely, and cost-effectively managed through recycling or composting.

- Segregation reduces the amount of hazardous substances released to the environment through disposal of general waste (i.e., by removing mercury from general waste).
- Segregation makes it easier to conduct assessment of the quantity and composition of different waste streams thereby allowing an HCF to obtain baseline data, identify options, determine waste management costs, and evaluate the effectiveness of waste minimization strategies.

6.3.2 Resource Development (3R's)

Another principle applied in waste minimization is Resource Development referring to the "3R's" or Safe Re-use, Recycle, and Recovery programs.

6.3.2.1 Safe re-use

Another option for the waste minimization is the safe re-use. Re-use is not only finding another use for a product but, more importantly, reusing the product repeatedly for a given function as intended. Promoting re-use entails the selection of reusable rather than disposable products whenever possible. Re-use will also entail setting reliable standards for disinfection and sterilization of equipment and materials for use (see **Box 19**). Reuse requires a realistic assessment of which reuse practices are considered safe and which to avoid because the risk of infection transmission to patients and staff is unacceptable.

When considering reuse, it is important to make a distinction between different types of products:

- Non-medical supplies, disposable items (which should be avoided);
- Medical devices that pose no cross-infection risk (e.g., blood pressure meters); and
- Medical devices specifically designed for reuse (e.g., surgical instruments).

Before the reuse of the product, it must undergo the following steps: (1) cleaning; (2) decontamination; (3) reconditioning; (4) disinfection; and (5) sterilization.

The following are the products that can be reused:

- Certain devices that are intended for limited reuse by the individual and only require washing with mild detergents (e.g., patient self-administered intermittent urinary catheters, face masks for oxygen administration);
- Long-term radionuclides conditioned as pins, needles, or seeds and used for radiotherapy may be reused after sterilization;
- Special measures must be applied in case of potential or proven

contamination with the causative agents of transmissible spongiform encephalopathies;

- Certain types of containers, provided they are carefully washed and disinfected;
- Pressurized gas containers should be sent to specialized centers to be refilled; and
- Containers that once held detergent/other liquids may be reused as containers for sharps waste (if purpose-made containers are not affordable), provided they are puncture-proof and clearly marked on all sides for used sharps.

Items that cannot be reused are the following:

- Single-use devices or items, such as syringes and hypodermic needles, must not be reused because of the risk of cross-infection. Where syringes are in short supply, nurses may replace the needle, but the chance of infection remains.
- Plastic syringes and catheters should not be reused. However, they may be recycled after sterilization.
- Disposable items such as gloves, masks and gowns should not be reused.

Box 19: Examples of sterilization methods for re-usable items

Thermal sterilization

- *Dry sterilization: Exposure to 160°C for 120 minutes or 170°C for 60 minutes in a "Poupinel" oven.*
- *Wet sterilization: Exposure to saturated steam at 121°C for 30 minutes in an autoclave.*

Chemical sterilization

- *Hydrogen peroxide: A 7.5% solution can produce high-level disinfection in 30 minutes at 20°C. Alternatively, equipment exists that can generate a hydrogen peroxide plasma from a 58% hydrogen peroxide solution. The equipment has a 45-minute process time. Hydrogen peroxide can also be used in combination with peracetic acid.*
- *Peracetic acid: Can produce sterilization in 12 minutes at 50–55°C, with instruments ready to use in 30 minutes. Peracetic acid can also be used in combination with hydrogen peroxide.*
- *OPA (ortho-phthaldehyde): High-level disinfection in 12 minutes at 20°C.*
- *Hypochlorous acid/hypochlorite: 400–450 ppm active free chlorine, contact conditions established by simulated use testing with endoscopes.*

NOTE: Ethylene oxide and glutaraldehyde are widely used but are being replaced in an increasing number of HCFs because of their health effects. Ethylene oxide is a human carcinogen, and glutaraldehyde can cause asthma and skin irritation.

The effectiveness of the thermal sterilization must be checked – Bacillus stearothermophilus test (thermal sterilization) and Bacillus subtilis test (chemical sterilization).

Reference: Safe Management of Wastes from Health-Care Activities, 2nd Edition (WHO, 2014)

6.3.2.2 Recycling

Recycling involves processing of used materials (waste) into new products to prevent loss of potentially useful materials, reduce the consumption of fresh raw materials, reduce energy usage, reduce air pollution and water pollution (from land filling) by reducing the need for “conventional” waste disposal and lower greenhouse gas emissions as compared to virgin production. However, from an environmental perspective, recycling is less desirable than reusing a waste item, because it frequently requires substantial energy input and transport to off-site recycling centers.

Recyclable materials include many kinds of glass, paper, metal, plastics (see **Box 19**), textiles, and electronics. Materials to be recycled are brought to a collection center or picked up from the curb side, then sorted, cleaned, and reprocessed into new materials bound for manufacturing.

Recycling is increasingly popular in some HCFs, especially for the large, non-hazardous portion of waste. It can reduce costs considerably, either through reduced disposal costs or through payments made by a recycling company for the recovered materials.

Some of the hazardous infectious portion of the waste will contain recyclable materials (e.g., paper, cardboard, packaging, tubing). These materials can also be recycled, provided they are disinfected to eliminate possible pathogens, and safe handling guidelines are followed.

Box 20: Recycling of plastics

To facilitate recycling, common plastics are now frequently labelled with internationally recognized symbols and numbers:

1	2	3	4	5	6	7
PETE	HDPE	PVC	LDPE	PP	PS	OTHER
polyethylene terephthalate	high-density polyethylene	polyvinyl chloride	low-density polyethylene	polypropylene	polystyrene	other plastics, including acrylic, polycarbonate, polyactic fibers, nylon, fiberglass
soft drink bottles, mineral water, fruit juice, container, cooking oil	milk jugs, cleaning agents, laundry detergents, bleaching agents, shampoo bottles, washing and shower soaps	trays for sweets, fruits, plastic packing (bubble foil) and food foils to wrap the foodstuff	crushed bottles, shopping bags, highly-resistant sacks and most of the wrappings	furniture, consumers, luggage, toys, as well as bumpers, lining and external borders of the cars	toys, hard packing, refrigerator trays, cosmetic bags, costume jewelry, CD cases, vending cups	

Unfortunately, many PVC products in health care, such as blood bags, gloves, enteral feeding sets and film wraps, are not labelled.

Reference: *Safe Management of Wastes from Health-Care Activities, 2nd Edition (WHO, 2014)*

6.3.2.3 Recovery

The recovery of waste is defined in two ways. Most simply, recovery refers to energy recovery, whereby waste is converted to fuel for generating electricity or for direct heating of premises. Alternatively, waste recovery is a term used to encompass three sub-sets of waste recovery: recycling, composting, and energy recovery.

6.3.3 End-of-Pipe: Composting

Although similar in effect, composting or other re-use of biodegradable waste is not typically considered recycling. Composting uses natural decomposition to turn food scraps and yard waste into nutrient-rich soil additives, thereby reducing the amount of solid waste for disposal in landfills. The resulting compost can be sold or donated to local farmers and gardeners or can be used for plants around the HCF.

Box 21: Composting techniques



Vermicomposting

Red worms in bins feed on food scraps, yard trimmings, and other organic matter to create high quality compost called castings. One pound of mature worms (approximately 800-1,000 worms) can eat up to half a pound of organic material per day. Worm bins are easy to construct and are also available for purchase. The bins can be sized to match the volume of food scraps that will be turned into castings. It typically takes 3 to 4 months to produce usable castings, which can be used as potting soil. The other by-product of vermicomposting known as "worm tea" is used as a high-quality liquid fertilizer for houseplants or gardens.



Aerated (Turned)
Windrow Composting

This involves forming organic waste into rows of long piles called "windrows" and aerating them periodically by manually or mechanically turning the piles. The ideal pile height is 4 to 8 feet with a width of 14 to 16 feet, large enough to generate heat and maintain temperatures but small enough to allow oxygen flow to the windrow's core. Large volumes of diverse wastes such as yard trimmings, grease, liquids, and animal by-products can be composted through this method.



Aerated Static Pile
Composting

Aerated static pile composting produces compost relatively quickly (within 3 to 6 months). It is suitable for a relatively homogenous mix and larger quantity of organic waste. However, it does not work well for composting animal by-products. Organic waste is mixed in a large pile, which is aerated by adding layers of loosely piled bulking agents (e.g., wood chips, shredded newspaper). The piles also can be placed over a network of pipes that deliver air into or draw air out of the pile. Air blowers might be activated by a timer or a temperature sensor.



In-vessel Composting

In-vessel composting can process large amounts of waste without taking up as much space as the windrow method. It can accommodate virtually any type of organic waste. It involves feeding organic materials into a drum, silo, concrete-lined trench, or similar equipment that allows good control of environmental conditions (i.e., temperature, moisture, airflow). The material is mechanically turned or mixed to aerate. This method produces compost in just a few weeks. It takes a few more weeks or months until it is ready to use because the microbial activity needs to balance, and the pile needs to cool.

Reference: *Safe Management of Wastes from Health-Care Activities*, 2nd Edition (WHO, 2014)

6.4 Administrative Control Measures

Green Procurement, the 3R's, and end-of-pipe solutions can be achieved through, among others, administrative control measures such as:

- Adopting Environmental Management System (EMS) as described in **Box 22**;
- Systemized use of product "first in, first out" (FIFO) or "first to expire, first out" (FEFO) for chemical and pharmaceutical products;
- Monitoring of chemical flows within the healthy facility from receipt as raw materials to disposal as hazardous waste;
- Elimination of medical supplies/equipment containing hazardous chemicals;
- Using less hazardous method in cleaning such as steam disinfection instead of chemical disinfection; and
- Checking the expiry date of all products at the time of delivery and based on its optimum consumption rate.

Box 22: Environmental Management System

An *Environmental Management System (EMS)* framework encompasses the environmental aspects of waste management, including reduction, reuse, and recycling. An EMS should be an integral part of an organization's approach to good management. It is used to develop and implement its environmental policy and to manage its continuing environmental impacts.



Key elements of an EMS should include the following:

- Process or mechanism for screening project plans and proposals for potential environmental risks; for example, using screening tools, checklists, and expert review;
- Development and use of environmental management plans that clearly define environmental mitigation measures to be taken, by whom, and at which point in the project's implementation;
- Monitoring and reporting activities to verify that relevant environmental management actions are being taken and that they are generating the intended results;
- Evaluation of the overall environmental performance of projects and activities to inform organizational learning and future environmental mitigation actions.

7 Health Care Waste Segregation, Collection, Storage, and Transport

This chapter describes the proper segregation of HCW at the point of generation, collection, storage, and transport for treatment prior to its final disposal. Segregation is the key to effective waste management and only implementation of proper waste management can ensure all HCW will be treated according to the hazards.

7.1 Principles

HCF managers have a “duty of care” to ensure that waste is kept under control at all times within the HCF and disposed of safely either on-site or off-site. The following general principles relate to the control of waste flow from generation to disposal:

- HCW is generated in a medical area and should be segregated into different fractions, based on their potential hazard and disposal route, by the person who produces each waste item.
- HCW must be segregated, collected, stored, and transported in a safe manner considering the risk and occupational safety and in accordance with existing laws, policies, and guidelines.
- Hazardous and general waste must not be mixed during collection, transport, and storage.
- Separate containers should be available in each medical area for each segregated waste fraction.
- Appropriate labelling, signage, route, and segregation system must be established. Waste containers when filled should be labelled to help managers control waste production.
- Plastic liners preferably containing three-quarters full of waste must be sealed when transported from waste generating source to the storage area.
- The storage area must be designed based on the volume of waste generated by the HCF and must be provided with compartments for general, hazardous, and recyclable wastes. Closed local storage inside or near to a medical area may be needed if wastes are not collected frequently.
- A separate storage area for phase-out mercury containing devices and products must be provided (as per DOH AO 2008-21 and DM 2011-0145).

- Staff must be well-trained on the risk and safety procedures on handling waste.
- The HCF must register as waste generator with the DENR and secure a DENR waste generator identification number.

7.2 HCW Segregation

Segregation is the process of separating different types of waste at the point of generation until its final disposal. The correct segregation of HCW is the responsibility of the person who produces each waste item, whatever their position in the organization.

Segregation at the point of generation reduces the health risk from the smaller potentially infectious fractions (typically waste items contaminated with body fluids and used sharps). With proper segregation, appropriate resource recovery and recycling technique can be applied to each separate waste stream. Proper segregation may also minimize the amount of hazardous wastes that needs to be treated thus, prolonging the operational life of the disposal facility and may gain benefit in terms of conservation of resources. To improve segregation efficiency and minimize incorrect use of bins, proper placement, labelling of waste bins and use of color-coded plastic liner must be strictly implemented.

Box 23: Minimum requirement for HCW segregation: three-bin system

The simplest waste segregation system is to separate all hazardous waste from the larger quantity of non-hazardous general waste. However, to provide a minimum level of safety to staff and patients, the hazardous waste portion is commonly separated into two parts: used sharps and potentially infectious items. Consequently, the segregation of general, non-hazardous waste, potentially infectious waste and used sharps into separate containers is often referred to as the "three-bin system." This is most applicable to the primary care facilities.



If classification of a waste item is uncertain, as a precaution it should be placed into a container used for hazardous HCW. Waste that has been poorly segregated should never be re-sorted, but instead should be treated as the most hazardous type of waste in the container.

Source: WHO & UNICEF, <https://slideplayer.com/slide/14374406/>

7.2.1 General Considerations after Basic Segregation

Within each major category (e.g., non-hazardous, potentially infectious, used sharps), further segregation of the HCW according to the categorization discussed in **Chapter 2.2** is needed when other hazardous waste is generated (e.g., pharmaceutical, pathological, chemical). In doing so, the following practices must be observed during segregation at the point of generation.

A. General / Non-hazardous waste

- As discussed in **Chapter 2.2**, general non-hazardous wastes may further be segregated into recyclables, biodegradables, and non-biodegradable/non-recyclable wastes. If these are mixed at the point of generation, it may prevent recyclables from being recovered.
- Food wastes can be collected from medical areas and returned directly to the kitchens. Non-hazardous biodegradable wastes (e.g., flowers) may be disposed of with kitchen waste. Aerosol containers can be collected with the general wastes.

B. Hazardous waste

- Sharps waste (needle and syringe combination) should be placed directly into the designated puncture-proof container.

- Highly infectious waste, such as diagnostic laboratory samples and waste from infectious patients in isolation, should be collected separately and disinfected at the point of generation. Once disinfected, the waste would leave a medical area in the infectious HCW container.
- Pathological waste must be refrigerated if not collected/treated within 24 hours.
- Anatomical waste, particularly recognizable body parts or fetal material, should be handled according to prevailing religious and cultural preferences (most commonly, authorized burial or cremation). In low-resource areas, placentas and other non-recognizable anatomical waste can be disposed of in a pit where it can biodegrade naturally.
- Various chemical and pharmaceutical wastes should be segregated and collected separately: subcategories include mercury, batteries, cadmium-containing wastes, photochemicals, stains and laboratory reagents, cytotoxic drugs, and other pharmaceuticals.
 - Liquid chemical wastes should never be mixed or disposed of down the drain but should be stored in strong leak-proof containers or amber disposal bottles. Expired and discolored pharmaceuticals shall be returned to the pharmacy for return to the manufacturers/supplier.
 - Pharmaceuticals should be kept in their original packaging to aid identification and prevent reaction between incompatible chemicals. Spilt and contaminated chemicals and pharmaceuticals should not be returned to the pharmacy but should go directly from the point of production to a waste store. Typically, they are stored and transported within the HCF in brown cardboard boxes and must be kept dry.
 - Wastes containing mercury shall be collected separately and be managed according to DOH Department Memorandum 2011-0145.
- Radioactive wastes may be stored in secure, radiation-proof repositories (leak-proof, lead-lined, and clearly labelled with the name of the radionuclide and date of deposition) where it should be left to decay naturally. If it has reached the background radiation level and is not mixed with infectious or chemical wastes, it can be considered as general waste. Radioactive wastes can also be collected and handled by registered service providers.

Box 24: Sharp containers

Sharps shall be placed in puncture-proof containers. Since sharps can cause injuries that leave people vulnerable to infection, both contaminated and uncontaminated sharps should be collected in a puncture-proof and impermeable container that is difficult to break open after closure.

Sharps containers may be disposable or designed for disinfection and reuse. Disposables are boxes made of plasticized cardboard or plastic; reusable designs are plastic or metal. Low-cost options include the reuse of plastic bottles or metal cans. If this is to be done, the original labels should be removed or obscured, and the containers should be clearly relabeled as "Sharps containers."

7.2.2 Waste Bins and Plastic Liners

7.2.2.1 Siting

Segregation should be carried out by the producer of the waste as close as possible to its place of generation, which means segregation should take place in a medical area, at a bedside, in an operating theatre or laboratory by nurses, physicians and technicians. The following must be considered in selecting the location of waste bins in the HCF:

- Hazardous waste containers should be located away from patients; typical sites are the sluice (utility) room, treatment room and nurses' station.
- Where containers for segregating hazardous and non-hazardous HCWs are in use, they should be located close together, wherever possible.
- Containers for hazardous waste like infectious waste should not be placed in public areas because patients and visitors may use the containers and come into contact with potentially infectious waste items.
- Only waste bins for general non-hazardous waste bins must be in public areas.
- Waste bins with yellow liners for infectious wastes shall be placed in, but not limited to, the following areas away from the public: Emergency Room, Outpatient Department, Laboratory, Radiology, Dental and Isolation Rooms, Infectious Wards, Dialysis and Nurses Stations. The alternative is establishing a limited number of locations in a medical area where general waste (black bags) and infectious HCW (yellow bags and sharps containers) are placed.
- Static bins should be located as close as possible to sinks and washing facilities, because this is where most staff will deposit gloves and aprons after treating patients. If the general waste container is closest to the sink or under a towel dispenser, it will encourage staff to place towels into the non-infectious receptacle.

- Unless patients are known or suspected to have readily transmitted infections, the assumption should be that general waste generated in a medical area is of low risk. However, if there is a known communicable infection (e.g., methicillin-resistant *Staphylococcus aureus*, tuberculosis, or leprosy), all waste used in and around the patient should be classed as an infection risk and placed in the yellow, potentially infectious waste container. This “blanket” approach to all waste being assumed to be infectious can be avoided where there is a high level of training and communication between the clinical and support staff. Waste from each patient should be treated according to their known infection status.
- If intervention at the bedside is required, a waste container should be taken to the bed – preferably placed on or at a trolley or cart. Sharps bins are also sometimes taken to a patient for drug administration or blood sampling. A mobile trolley with infectious waste and sharps containers may therefore be more versatile and should be given serious consideration.

7.2.2.2 Specifications

Waste bins are of different types. Some bins are designed for automated system others are re-used plastic and metal containers. The general specifications of the waste bins and plastic liners that must be followed are as follows:

- The most important is the quality of material – it shall be sturdy and leak-proof;
- Bins shall have well-fitting lids, either removable by hand or operated by a foot pedal;
- Both bins and plastic liners shall be preferably of the same color for the type of waste intended to be placed. This is to avoid confusion and poor segregation;
- The recommended thickness of the plastic liners is 0.07mm (ISO 7765 2004). Plastics used for either containers or bags should be chlorine-free. Not all plastic bags can withstand temperatures of 121°C, and some can melt during an autoclave process;
- Containers should be large enough for the quantity of waste generated at that location during the period between collections; and
- Containers should be of similar size to overcome the observed tendency for staff to put waste in the largest receptacle.

The appropriate waste receptacle (bags, bins, sharps boxes) should be available to staff in each medical and other waste-producing area in the HCF. This permits staff to segregate and dispose of waste at the point of generation and reduces the need for staff to carry waste through a medical area. The specifications of waste bin/container and plastic liner per type of HCW are provided in **Table 4**.

7.2.2.3 Color-Coding

The purpose of color-coding is to make it easier for HCF workers to put the waste into correct bins and maintain segregation during collection, storage, transport, treatment, and disposal. The color-coding scheme of waste bin/container and plastic liner per type of HCW is likewise indicated in **Table 4**. HCFs may adopt the color-coded waste bin or innovate using recycled materials. However, strict compliance shall be observed in the use of corresponding plastic liners and proper labelling.

7.2.2.4 Labelling and Marking

Proper tagging of plastic liners before placing on the waste bin is to be strictly implemented. The tag of the plastic liner shall indicate the following:

- Name of the HCF;
- Area of the HCF where the waste was generated (or the source);
- Type of waste and the weight and date of collection on-site, or date and time of closure of the container; and
- Name of the person filling out the label.

The waste bins must also be labelled according to the type of waste so as to avoid confusion in the disposal of the wastes. The label must contain the DENR-EMB symbols representing the hazard classifications of the wastes or any necessary hazard labels. Refer to **ANNEX E 1**. These symbols must have the following specification when used in the tags:

- The minimum size of the symbol is 25cm x 25cm for vessels, containers, and tanks and 30cm x 30cm for conveyances carrying vessels, containers, and tanks;
- Basic shape of the symbols is a square rotated 45 degrees to form a diamond;
- At each of the four sides, a parallel line shall be drawn to form an inner diamond of the outer diamond; and
- The color should follow the colors specified.

The labelling and marking requirements for the waste bin/container and plastic liner per type of HCW are also described in **Table 4**.

Table 4: HCW bins and plastic liners specifications, color-coding, marking/labelling

Type of HCW		Specifications	Color-coding	Markings/Labeling
SHARPS: Bin/container	<i>Bin/ container</i>	<ul style="list-style-type: none"> Puncture proof container with wide mouth and cover. 	Yellow	<ul style="list-style-type: none"> Properly labelled "Sharps" With label indicating source and weight of waste generated and date of collection. With Biohazard symbol.
	<i>Plastic liner</i>	<ul style="list-style-type: none"> Strong, leak-proof plastic bag Can withstand autoclave Thickness: 0.07mm (70µm) Sample sizes: XL size (39cm x 39cm x 95cm) – Size varies depending on waste volume 	Yellow	<ul style="list-style-type: none"> Properly labelled "Infectious Waste" Tag indicating source and weight of waste generated, date of collection Biohazard symbol optional
INFECTIOUS WASTE: Bin/container with plastic liner	<i>Bin/ container</i>	<ul style="list-style-type: none"> Strong, leak-proof bin with cover Size varies depending on waste volume 	Yellow	<ul style="list-style-type: none"> Properly labelled "Infectious Waste" With Biohazard symbol
	<i>Plastic liner</i>	<ul style="list-style-type: none"> Strong, leak-proof bin with cover Size varies depending on waste volume 	Yellow	<ul style="list-style-type: none"> Properly labelled "Pathological Waste" With Biohazard symbol
PATHOLOGICAL WASTE: Bin/container with plastic liner	<i>Bin/ container</i>	<ul style="list-style-type: none"> Strong, leak-proof bin with cover Size varies depending on waste volume 	Yellow	<ul style="list-style-type: none"> Properly labelled "Pathological Waste" Tag indicating source and weight of waste generated, date of collection Biohazard symbol optional
	<i>Plastic liner</i>	<ul style="list-style-type: none"> Thickness: 0.07mm Sample sizes: XL size (39cm x 39cm x 95cm) – Size varies depending on waste volume 	Yellow	<ul style="list-style-type: none"> Properly labelled "Anatomical Waste" With Biohazard symbol
ANATOMICAL WASTE: Bin/container with plastic liner	<i>Bin/ container</i>	<ul style="list-style-type: none"> Strong, leak-proof bin with cover Size varies depending on waste volume 	Yellow	<ul style="list-style-type: none"> Properly labelled "Anatomical Waste" With Biohazard symbol
	<i>Plastic liner</i>	<ul style="list-style-type: none"> Thickness: 0.07mm Sample sizes: XL size (39cm x 39cm x 95 m) – Size varies depending on waste volume 	Yellow	<ul style="list-style-type: none"> Properly labelled "Pharmaceutical Waste" – expired drugs and containers "Cytotoxic Waste" "Genotoxic Waste"– cytotoxic, genotoxic,
PHARMACEUTICAL WASTE: Bin/container with additional plastic liner for cytotoxic or liquid waste	<i>Bin/ container</i>	<ul style="list-style-type: none"> Strong, leak-proof bin with cover Size varies depending on waste volume 	Brown	<ul style="list-style-type: none"> Properly labelled "Pharmaceutical Waste" – expired drugs and containers "Cytotoxic Waste" "Genotoxic Waste"– cytotoxic, genotoxic,

Type of HCW		Specifications	Color-coding	Markings/Labeling
	<i>Plastic liner</i>	<ul style="list-style-type: none"> Thickness: 0.07mm Sample sizes: XL size (39cm x 39cm x 95cm) – Size varies depending on waste volume 	Brown	<ul style="list-style-type: none"> and antineoplastic waste Properly labelled “Pharmaceutical Waste” – expired drugs and for containers “Cytotoxic Waste” “Genotoxic Waste”– cytotoxic, genotoxic, and antineoplastic waste Tag indicating source and weight of waste generated, date of collection
CHEMICAL WASTE: Bin/Container	<i>Bin/ container</i>	<ul style="list-style-type: none"> Strong, leak-proof bin with cover Material must be resistant to the wasted chemical Size varies depending on the volume of waste 	Brown	<ul style="list-style-type: none"> Properly labelled “Chemical Waste”
RADIOACTIVE WASTE: Bin/container with plastic liner	<i>Bin/ container</i>	<ul style="list-style-type: none"> Radiation proof repositories, leak proof and lead-lined container Size varies depending on waste volume 		<ul style="list-style-type: none"> Properly labelled “Radioactive Waste” Labelled with the name of radionuclide and date of deposition with radioactive symbol
	<i>Plastic liner</i>	<ul style="list-style-type: none"> Thickness: 0.07mm 	Orange	<ul style="list-style-type: none"> Properly labelled “Radioactive Waste” Labelled with the name of radionuclide and date of deposition
NON-BIODEGRADABLE WASTE (NON-HAZARDOUS GENERAL WASTE): Bin/container with plastic liner	<i>Bin/ container</i>	<ul style="list-style-type: none"> Size varies depending on the volume of radioactive waste 	Black	<ul style="list-style-type: none"> Properly labelled “Non-biodegradable Waste” Recyclable symbol optional
	<i>Plastic liner</i>	<ul style="list-style-type: none"> Thickness: 0.07mm Sample sizes: XL size (39cm x 39cm x 95cm) – Size varies depending on waste volume 	Black or Colorless	<ul style="list-style-type: none"> Properly labelled “Non-biodegradable Waste” Tag indicating source and weight of waste generated, date of collection
BIODEGRADABLE WASTE (NON-HAZARDOUS GENERAL WASTE): Bin/container with plastic liner	<i>Bin/ container</i>	<ul style="list-style-type: none"> Size varies depending on the volume of radioactive waste 	Green	<ul style="list-style-type: none"> Properly labelled “Biodegradable Waste”
	<i>Plastic liner</i>	<ul style="list-style-type: none"> Thickness: 0.07mm (70µm) Sample sizes: XL size (39cm x 39cm x 95cm) – Size varies depending on waste volume 	Green	<ul style="list-style-type: none"> Properly labelled “Biodegradable Waste” Tag indicating source and weight of waste generated, date of collection
<p>Note: the use of colorless plastic liner shall be allowed for security purposes and for easier monitoring of proper waste segregation.</p>				

7.2.3 Maintaining Standards in Segregation

To successfully implement segregation in all areas of the HCF, consider the following:

- Segregation methods should be clearly set out in the HCWM policy;
- It is important that the HCWM policy is supported and enforced by senior staff and managers;
- Medical staff and waste handlers should understand the reasons for, and operation of, segregation practices, waste auditing, spill management, and accident and injury reporting;
- Training should be repeated periodically to ensure that all staff are reminded of their responsibilities;
- The HCWM Committee is responsible for seeing that segregation rules are enforced; and
- Segregation posters for medical and waste workers help to raise knowledge about segregation practices and improve quality of separated waste components.

7.3 Collection and Transport within the HCF

Proper collection and transport of HCW is an important component in HCWM. Its implementation requires commitment and cooperation of the HCF's maintenance, housekeeping, and motor pool services personnel and all the HCF workers. HCW collection and transport practices shall be designed to achieve an efficient movement of waste from point of generation to storage or treatment while minimizing the risk to the personnel.

7.3.1 On-site Collection of HCW

This refers to the collection of wastes from the waste bins going to the on-site storage area of the HCF by the general service personnel. Collection times should be fixed and appropriate to the quantity of waste produced in each area of the HCF. The following are the general guidelines for the on-site collection of the HCW.

- Follow the established plan for the collection and transport of HCW.
- Infectious and general waste should be collected daily (or as frequently as required) with collection time matching the pattern of waste generation during the day. For example, in a medical area where the morning routine begins with the changing of dressings, infectious waste could be collected mid-morning to prevent soiled bandages remaining in the medical area for longer than necessary. Visitors arriving later in the day will bring with them an increase in general waste, such as newspapers and

food wrappings; therefore, the optimum time for general and recyclable waste collection would be after visitors have departed.

- Waste bags should be filled to no more than three-quarters full. Once this level is reached, they should be sealed ready for collection. Plastic bags should never be stapled but may be tied or sealed with a plastic tag or tie.
- Sharp containers should be collected when three-quarters full.
- Pharmaceutical and chemical waste can be collected on demand.
- Radioactive waste should be collected after finalization of the procedure.
- Upon waste collection, the personnel must ensure that the waste bags and containers are properly labelled as discussed in **Chapter 7.2.2**.
- Replacement bags or containers should be available at each waste collection location so that full ones can immediately be replaced.
- A monitoring sheet for the collection of the wastes must be filled out by the personnel upon collection. A sample monitoring sheet is shown in **ANNEX D 5**.

7.3.2 On-site Transport of HCW

This refers to the transport of the wastes from the point of generation to the on-site waste storage area. In doing the on-site transport, the following must be observed:

- Transport of the collected HCW must be done using wheeled trolleys/carts or wheeled bins;
- On-site transport should take place during less busy times whenever possible. Set routes should be used to prevent exposure to staff and patients and to minimize the passage of loaded carts through patient care and other clean areas;
- Depending on the design of the HCF, the internal transport of waste should use separate floors, stairways, or elevators as far as possible. On-site transport of HCW in HCFs with more than two-story building/s shall use service elevators, mechanical pulley, hoist, or ramp. In the case of elevators or ramps, the schedule of on-site transport of HCW shall be prior to the end of shift of workers, preferably not coinciding with scheduled visiting hours;
- Regular transport routes and collection times should be fixed and reliable;
- Transport staff should wear adequate personal protective equipment, gloves, strong and closed shoes, overalls, and masks;
- Hazardous and non-hazardous waste should always be transported separately. The use of waste chutes in HCFs is not recommended, because they can increase the risk of transmitting airborne infections;

- Hazardous waste should never be transported by hand due to the risk of accident or injury from infectious material or incorrectly disposed sharps that may protrude from a container;
- General wastes should not be collected and transported at the same time as the infectious or other hazardous wastes;
- Infectious waste can be transported together with used sharps wastes. Infectious waste should not be transported together with other hazardous waste, to prevent the possible spread of infectious agents;
- Other hazardous waste, such as chemical and pharmaceutical wastes, should be transported separately in boxes.
- The trolleys shall be disinfected after every use. The on-site transport trolley shall be cleaned and disinfected daily using 4-5% concentration of sodium hypochlorite (NaClO).
- Spare trolleys should be available in case of breakdowns and maintenance.

7.3.2.1 Transport trolley or cart

There should be a dedicated transport trolley or cart for each waste category. There should be at least a cart dedicated for infectious waste, non-biodegradable and for biodegradable/recyclable. The transport trolleys or carts should be colored based on the appropriate colored code and properly labelled.

- Waste transportation carts for general waste should be painted black, only be used for non-hazardous waste types, and labelled clearly "General waste" or "Non-hazardous waste".
- For infectious wastes, the transportation carts should be painted yellow and clearly labelled with "Infectious waste" sign.

The transport wheeled trolley or cart can be single or can accommodate up to three collection bins. To avoid injuries and infection transmission, trolleys and carts should meet the following requirements:

- a) Easy loading and unloading, be easy to push and pull with heavy duty wheel caster;
- b) Be easy to clean and, if enclosed, fitted with a drainage hole and plug;
- c) Have no sharp edges that could damage waste bags or containers during loading and unloading;
- d) Be labelled and dedicated to a particular waste type;
- e) Not be too high (to avoid restricting the view of staff transporting waste);
- f) Be secured with a lock (for hazardous waste); and

- g) Be appropriately sized according to the volumes of waste generated at the HCF.

7.3.2.2 HCW transport routing

In general, a waste route should follow the principle “from clean to dirty”. Collection should start from the most hygienically sensitive medical areas (e.g., intensive care, dialysis, theatres) and follow a fixed route around other medical areas and interim storage locations. Upon departure from the source, no further handling shall be done. An efficient and effective collection system route shall consider the following:

- a) Assignment of worker responsible for the zone or area;
- b) Logical planning of the route (shall avoid passing congested areas);
- c) Schedule of collection;
- d) All logical progression of HCW, and waste type;
- e) Waste volume and number of waste bags or containers;
- f) Capacity of the waste storage within medical areas and at interim storage area;
- g) Capacity of the transportation trolleys;
- h) Transport distances and journey times between the collection points; and
- i) Established routing plan can be revised if circumstances warrant it.

A sample HCW transport route plan is provided in **ANNEX E 2**. The route plan shall be posted from point of generation to the storage area.

7.4 On-site Storage of HCW

7.4.1 Interim Storage in Medical Departments

For hospitals, hazardous waste generated in medical areas should be stored in utility rooms, which are designated for cleaning equipment, dirty linen, and waste. From here, the waste can be kept away from patients before removal, then collected conveniently and transported to a central storage facility. This is known as interim or short-term storage.

For other HCFs that do not have available utility rooms, waste can be stored at another designated location near to a medical area but away from patients and public access. Another possibility for interim storage is a closed container stationed indoors, within or close to a medical area. A storage container used for infectious waste should be clearly labelled and preferably lockable.

7.4.2 Central Storage

Central storage areas are places within the HCF where different types of waste should be brought for safe retention until it is treated or collected for transport off-site. A storage location for HCW should be designated within the HCF. Space for storing wastes should be incorporated into a building design when new construction is undertaken. The HCF shall have separate storage areas for the following:

- a) General wastes;
- b) Recyclable materials;
- c) Hazardous waste (other than phased-out mercury devices); and
- d) Phased-out mercury devices;

If there is area available for composting of biodegradable wastes, storage area is not necessary. It must be disposed of directly in composting site. The HCF must use appropriate containers in storing the wastes in the central storage and must also be properly labelled in compliance with DAO 2013-22 Revised Procedures and Standards for the Management of Hazardous Wastes.

7.4.2.1 General requirements for the central storage area (except for phased-out mercury devices)

The general requirements for the central storage areas are listed below:

- Located within the HCF or research facility. However, these areas must be located away from the dietary section, patient rooms, laboratories, hospital function/operation rooms or any public access areas. It shall be protected from rain, strong winds, floods, etc.;
- Easily accessible to the staff in charge of handling the waste and for waste collection vehicle without entering HCF premises;
- Locked at all times to prevent access of unauthorized persons and entry of animals, insects, and birds;
- Floor level higher than the anticipated flood level of the area during heavy rainfall with concrete flooring that is waterproofed and adequately sloped for easy cleaning and finished with ceramic tiles;
- With impermeable, hard-standing floor with good drainage and connected to a wastewater treatment plant;
- With continuous water supply for cleaning purposes and have a washing basin with running tap water and soap that is readily available for the staff;
- With adequate ventilation, lighting, and electrical supply;
- With supply of cleaning implements such as a water hose with spray nozzle, scrubber with long handle, disinfectant, protective clothing, waste bags or bins and fire-fighting equipment/devices located conveniently close to

the storage area; or have spillage containment equipment;

- Appropriate to the volumes of waste generated from each HCF; and
- With the warning sign posted in a conspicuous place: "CAUTION: HEALTH CARE WASTE STORAGE AREA – UNAUTHORIZED PERSONS KEEP OUT";

7.4.2.2 Hazardous waste storage requirements

In addition to the general requirements, the following specification must be considered for the hazardous waste storage. Hazardous waste should always be stored in enclosed rooms.

A. Infectious Waste Storage

- The storage place must be identified as an infectious waste area by using the biohazard sign.
- Floors and walls should be sealed or tiled to allow easy disinfection. If present, the storage room should be connected to a special sewage system for infectious hospital wastewater.
- The compacting of untreated infectious waste or waste with a high content of blood or other body fluids destined for off-site disposal (for which there is a risk of spilling) is not permitted.
- Infectious waste should be kept cool or refrigerated at a temperature preferably no higher than 3°C to 8°C if stored for more than a week, also sharps can be stored without problems.
- Unless a refrigerated storage room is available, storage times for infectious waste (e.g., the time gap between generation and treatment) should not exceed 48 hours during the cool season and 24 hours during the hot season.

B. Pathological Waste Storage

- Pathological waste and the growth of pathogens it may contain are considered as biologically active waste, and gas formation during storage should be expected. To minimize these possibilities, the storage places should have the same conditions as those for infectious and sharps wastes.
- Body parts passed to the family for ritual procedures or buried in designated places should be placed in sealed bags to reduce infection risks before release to the public.

C. Pharmaceutical Waste Storage

- In general, pharmaceutical wastes can be hazardous or non-hazardous, and liquid or solid in nature, and each should be handled differently.
- Pharmaceutical waste with non-hazardous characteristics that can be stored in a non-hazardous storage area:

- ampoules with non-hazardous content (e.g., vitamins); - fluids with non-hazardous contents, such as vitamins, salts (sodium chloride), amino salts;
- solids or semi-solids, such as tablets, capsules, granules, powders for injection, mixtures, creams, lotions, gels, and suppositories; and
- aerosol cans, including propellant-driven sprays and inhalers.
- Hazardous waste that should be stored in accordance with their chemical characteristics (e.g., genotoxic drugs) or specific requirements for disposal (e.g., controlled drugs or antibiotics):
 - controlled drugs (should be stored under government supervision);
 - disinfectants and antiseptics;
 - anti-infective drugs (e.g., antibiotics);
 - genotoxic drugs (genotoxic waste) -highly toxic and should be identified and stored carefully away from other HCW in a designated secure location; and
 - ampoules with, for example, antibiotics.

D. Chemical Waste Storage

- For hazardous chemical waste, the characteristics of the different chemicals to be stored and disposed of must be considered (flammable, corrosive, explosive).
- The storage place should be an enclosed area and separated from other waste storage areas. The storage area itself should have adequate lighting and good ventilation to prevent the accumulation of toxic fumes. Sample layout is shown in **ANNEX E 3**.
- When storing liquid chemicals, the storage should be equipped with a liquid- and chemical-proof sump. If no sump is present, catch-containers to collect leaked liquids should be placed under the storage containers.
- Spillage kits, protective equipment and first aid equipment (e.g., eye showers) should be available in the central storage area.
- To ensure the safe storage of chemical wastes, the following separate storage zones should be available to prevent dangerous chemical reactions:
 - explosive waste;
 - corrosive acid waste;
 - corrosive alkali waste (bases);
 - toxic waste;

- flammable waste;
 - oxidative waste;
 - halogenated solvents (containing chlorine, bromine, iodine, or fluorine); and
 - non-halogenated solvents.
- The storage zones should be labelled according to their hazard class. If more than one hazard class is defined for a specific waste, use the most hazardous classification.
 - Liquid and solid waste should be stored separately. If possible, the original packaging should be taken for storage too. The packaging used to store and transport chemical wastes off-site should also be labelled. This label should have the following information: hazard symbol(s), waste classification, date, and point of generation (if applicable).
 - The storage area for explosive or highly flammable materials must be suitably ventilated above and below, with a bonded floor and constructed of materials suitable to withstand explosion or leakage.

E. Radioactive Waste Storage

- Radioactive waste should be stored in containers that prevent dispersion of radiation and stored behind lead shielding.
- Waste that is to be stored during radioactive decay should be labelled with the type of radionuclide, date, period of time before full decay, and details of required storage conditions. Radioactive waste shall be separated according to the length of time needed for storage.
- The decay storage time for radioactive waste differs from other waste storage, because the main target will be to store the waste until the radioactivity is substantially reduced and the waste can be safely disposed of as normal waste.
- A minimum storage time of 10 half-life times for radioisotopes in wastes with a half-life of less than 90 days is a common practice.
- Infectious radioactive waste should be decontaminated before disposal. Sharp objects such as needles, Pasteur pipettes and broken glass should be placed into the designated container for sharps.
- Liquids associated with solid materials, such as assay tube contents, should be decanted or removed by decay time.
- All radioactive labelling should be removed on any items to be disposed of.
- Empty containers of radionuclides solution are stored in dedicated empty

room for certain number of days until it decays to background level.

- Storage places must be equipped with sufficient shielding material, either in the walls or as movable shielding screens. The storage must be clearly marked with "RADIOACTIVE WASTE", and the international hazard label should be placed on the door.
- The storage place should be constructed in a manner that renders it flame-proof and should have such surfaces on floors, benches and walls that allow proper decontamination. An air-extraction system and radioactive monitoring system should be put in place.

F. Mercury-containing Waste Storage

- Mercury wastes shall be collected and stored in the designated storage area. It shall be clear that the mercury wastes require a more thorough storage system.
- Mercury containing products must be stored in non-breakable containers with tight-fitting lids. The containers must be clearly labelled as to their contents.
- Rooms where mercury containing items are stored shall be tested periodically using a mercury vapor sniffer or analyzer.
- Even after the use of mercury has long been discontinued in the HCF, mercury containing products may still be in storage from past uses. All HCF shall check storage areas for old, damaged, or outdated equipment. If mercury-containing products are found, contact the HCWM Officer.
- After the removal of the mercury containing products, the areas shall be checked with the mercury vapor sniffer or analyzer.
- HCF shall keep a permanent record of all materials brought in and out of the mercury storage area.
- Safe handling, transport and temporary storage of mercury wastes and the management of mercury spills must be in accordance to the DOH Department Memorandum No. 2011-0145.

7.4.3 **Layout of Waste Storage Areas**

If new HCWM systems are developed and if new infrastructure is planned, a "waste yard" should be built. A waste yard is where all the relevant waste management activities are brought together. To concentrate certain tasks, it is best to set up multifunctional buildings (waste-storage area), including a fenced storage area for general waste, a room for infectious waste, a treatment room, a fenced area with an ash or sharps pit, a container cleaning room and a clean office with lockers and toilets. Refer to **ANNEX E 4** for a sample layout of waste storage area.

7.4.4 Documentation of Operation in Waste Storage Places

For easier monitoring of the wastes that are being stored, the personnel in-charged must maintain a record of the waste stored and the dates of its storage, treatment, and disposal. In addition, the following are also needed to ensure the safe storage of HCW:

- a written spill contingency plan;
- a weekly store inspection protocol;
- protocols for using, repairing, and replacing emergency equipment;
- training system and documentation (names of trained staff, job descriptions, form of training, date of training, date for refresher or revalidation training);
- hazardous waste storage documentation; and
- collection of relevant material safety data sheets (MSDS).

Box 25: Minimum requirements for HCW storage

The following are the minimum requirements for storage of HCW:

- *Infectious, general, and used sharps waste are stored in separate color-coded containers and locations within medical areas, and subsequently at a central storage site at the HCF.*
- *Central storage area(s) are fenced, lockable and isolated from patients and the public.*
- *Maximum storage times before treatment or disposal of infectious waste are not longer than- 48 hours during the cooler season and 24 hours during the hot season.*
- *Staff receive instruction on three-bin waste segregation and safe handling and storage of HCW.*
- *Staff are aware of how to protect themselves from injuries and infection from waste.*
- *Waste containers and storage areas are cleaned regularly.*

Reference: Safe Management of Wastes from Health-Care Activities, 2nd Edition (WHO, 2014)

7.5 Off-site Collection

This refers to the collection of waste from the HCF on-site central storage area by an accredited DENR transporter, Municipal Collector or Supplier into their respective vehicles. The waste collector at this point will depend on the type of waste collected.

The HCW generator is responsible for the safe packaging and adequate labelling of waste to be transported off-site for treatment and disposal. Packaging and labelling shall comply with the requirements of the national regulation governing the transport of hazardous wastes (RA 6969) and must not present danger to the public during transport. The off-site collector of HCW shall provide collection bins that meet the following requirements:

- Puncture-proof for sharps;

- Resistant to aggressive chemicals;
- Made of high-density polyethylene materials (HDPE);
- Must be leak-proof and be fitted with a self-sealing lid that is tight enough to withstand turbulence during transport in the vehicle; and
- Must follow the requirements of EMB-DENR in DAO 2013-22.

Infectious and pathological waste must be placed in appropriate color-coded or other special bins when transported. In case of radioactive wastes, it must be packaged for off-site collection and transported in accordance with the accepted criteria for low level radioactive wastes established by PNRI (AO No. 01 series of 1990).

7.6 Off-site Transport

This refers to the transport of waste from the central storage of the HCF to a TSD or to the final disposal site. The transporter shall comply with DENR requirements and be registered with the DENR as waste transporter.

The requirements for off-site transport vehicles are listed in **ANNEX B 3**. A sample placard for off-site transport vehicle is shown in **ANNEX E 5**.

The waste generators are ultimately responsible for ensuring that their HCW are properly treated and disposed of in an approved disposal facility. Tracking of HCW could be done with the implementation of the consignment system and through the Hazardous Waste Manifest System of the EMB. The authorized transporter/carrier shall maintain a completed consignment note of all HCW for treatment or disposal and an updated transport permit. The transporter and generator shall separately maintain a copy of the consignment note.

Refer to **ANNEX B 2** for the consignment note requirements and **ANNEX D 3** for the template.

Box 26: Minimum measures for HCW transport

The following are minimum measures for transporting HCW:

- General waste and infectious HCW is collected separately and at least once a day.
- Collection is at regular times and is reliable.
- Waste containers and on-site transport trolleys are closed with lids to isolate wastes from patients and the public.
- Where wastes are transported off-site for disposal, the vehicle can carry wastes in a closed or covered container, and the driver knows what to do if there is an accident or incident during transportation on public roads.
- Transport staff are vaccinated at least against hepatitis A and B, polio, and tetanus.
- Waste containers, trolleys, and vehicles are maintained and cleaned regularly.

Reference: Safe Management of Wastes from Health-Care Activities, 2nd Edition (WHO, 2014)

8 Health Care Waste Treatment and Disposal

The purpose of treatment is to reduce the potential hazard posed by HCW, while endeavoring to protect the environment. Treatment should be viewed in the context of the waste management hierarchy described in **Chapter 6**. This chapter illustrates different technologies and methods in waste treatment and disposal. After treatment, the wastes should be stored in plastic liners/containers with the same color as stated in **Chapter 7**.

8.1 Selection of Treatment Methods

In determining the method to be used in HCW treatment and disposal by any HCF, the HCF administrator must look into several requirements and conditions relevant to HCWM. The choice of treatment system involves consideration of waste characteristics, technology capabilities and requirements, environmental and safety factors, and costs – many of which depend on local condition. The treatment technology must comply with the national standards and international conventions.

Factors to consider include: types and quantity of waste for treatment and disposal/capacity of the system; treatment efficiency; volume and mass reduction; occupational health and safety and environmental considerations; infrastructure and space requirements; locally available treatment options for final disposal; training requirements for operation of the method; cost of operation and maintenance; location/surroundings of the treatment site and disposal facility; regulatory requirements; social and political acceptability; cost of transport and disposal of treated waste; and cost of decommissioning.

Box 27: Selecting HCW treatment and disposal methods for primary care facilities

In choosing the option for treatment and disposal of HCW from primary care facilities, the following conditions must be considered:

- *The quantities of waste produced daily at the PHC level*
- *Availability of appropriate sites for waste treatment and disposal*
- *Possibility of treatment in central facility or treatment facility within reasonable distance.*
- *Rainfall and level of groundwater (e.g., to take precautions against flooding of burial pits)*
- *Availability of reliable transportation*
- *Compliance to the national policies and standards*
- *The availability of equipment and manufacturers in the country or region*
- *Social acceptance of treatment and disposal methods and sites*
- *Space available at the HCF*
- *Availability of resources (human, financial, material)*
- *Estimate of capital and operating cost*

Reference: Safe Management of Wastes from Health-Care Activities, 2nd Edition (WHO, 2014)

The selection of HCW technology goes far beyond cost implications since this may have significant impact on the environment, the workers in the treatment and disposal facilities and the surrounding community. Several questions need to be asked and answered regarding this matter, refer to some guide questions provided in **ANNEX B 4** of this Manual.

8.2 Basic Treatment Processes

The treatment of hazardous wastes, particularly sharps, infectious, and pathological wastes, consists of five basic processes: thermal, chemical, irradiation, biological, which may be connected with mechanical processes. The minimum treatment required for the HCW is disinfection.

Box 28: Microbial inactivation

The largest proportion of hazardous HCW generated is potentially infectious. The most established waste management technologies focus on disinfection. Disinfection can be defined as the reduction or removal of disease-causing microorganisms (pathogens) to minimize the potential for disease transmission. Sterilization is defined as the destruction of all microbial life. Since the complete destruction of all microorganisms is difficult to establish, sterilization of medical and surgical instruments is generally expressed as a 6 log₁₀ reduction (i.e., a 99.9999% reduction) or greater of a specified microorganism that is highly resistant to the treatment process. A 6 log₁₀ reduction, sometimes also written as “log 6 kill”, corresponds to a one millionth (0.000001) survival probability of the microbial population. On the other hand, disinfection is defined as low, intermediate, or high (using the Spaulding system) depending on the survival probability of specific microbial groups.

The State and Territorial Association on Alternate Treatment Technologies (STAATT) classification system, in lieu of the terms disinfection or sterilization, denotes levels of “microbial inactivation” specifically for HCW treatment. The classification system was established to define measures of performance of HCW treatment technologies. The levels defined for microbial inactivation are:

- Level I Inactivation of vegetative bacteria, fungi, lipophilic viruses at 6log₁₀ reduction or greater
- Level II Inactivation of vegetative, fungi, lipophilic/hydrophilic viruses, parasites, and mycobacteria at 6log₁₀ reduction or greater
- Level III Inactivation of vegetative bacteria, fungi, lipophilic/hydrophilic viruses, parasites, and mycobacteria at a 6log₁₀ reduction or greater; and inactivation of *B. stearothermophilus* spores and *B. subtilis* spores at 4log₁₀ reduction or greater
- Level IV Inactivation of vegetative bacteria, fungi, lipophilic/hydrophilic viruses, parasites and mycobacteria and *B. stearothermophilus* spores at a 6log₁₀ reduction or greater.

A common microbial inactivation standard for HCW treatment based on the STAATT criteria is Level III. Regular testing of the efficacy of disinfection techniques is important.

Reference: *Safe Management of Wastes from Health-Care Activities, 2nd Edition (WHO, 2014)*

8.2.1 Thermal Processes

Thermal treatment processes rely on heat (thermal energy) to destroy pathogens contained in the waste. This category can be further subdivided into low-heat and high-heat designs. This sub-classification is useful because of the marked differences

in the thermochemical reactions and physical changes taking place in the wastes during their treatment in the different types of equipment. These differences produce very different atmospheric emissions characteristics.

Low-heat thermal processes are those that use thermal energy at elevated temperatures high enough to destroy microorganisms but not sufficient to cause combustion or pyrolysis of the waste. In general, low-heat thermal technologies operate between 100°C and 180°C. The low-heat processes take place in either moist or dry-heat environments.

- Pyrolysis is the thermal degradation of a substance through the application of heat in the absence of oxygen. Pyrolysis is a special case of thermolysis and is most commonly used for organic materials. It occurs at high temperatures but does not involve reactions with oxygen. In practice, it is difficult to have a completely oxygen-free atmosphere, so some oxidation takes place.
- Microwave treatment is essentially a moist thermal process, because disinfection occurs through the action of moist heat (hot water and steam) generated by the microwave energy.
- Dry-heat processes use hot air without the addition of water or steam. In dry-heat systems, the waste is heated by conduction, convection and/or thermal radiation using infrared or resistance heaters.
- Moist (or wet) thermal treatment involves the use of steam to disinfect waste and is commonly performed in an autoclave or steam-based treatment system.

8.2.2 Chemical Processes

Infectious wastes can also be decontaminated by using chemicals. Chemical treatment processes often involve shredding, grinding, or mixing to increase exposure of the waste to the chemical agent.

The speed and efficiency of chemical decontamination depends on operational conditions, including the type of chemical disinfectant used, its concentration, the contact time between the disinfectant and the waste, the extent of contact, the organic load of the waste, operating temperature, and factors that may affect the efficacy of the disinfectant such as humidity and pH. Chemicals used should be neutralized prior to discharge.

- Chemical treatment methods use disinfectants such as dissolved chlorine dioxide, bleach (sodium hypochlorite), peracetic acid, lime solution, ozone gas or dry inorganic chemicals (e.g., calcium oxide powder). However, the soaking of infectious and sharp waste in chlorine solutions have become less used due to concerns of environmental and occupational safety. Manual systems using chemical disinfection are not

regarded as a reliable method for the treatment of waste.

- Chemical system that uses heated alkali to digest tissues, pathological waste, anatomical parts, and animal carcasses in heated stainless-steel tanks.

8.2.3 Biological Processes

Biological treatment processes are found in natural living organisms but refer specifically to the degradation of organic matter when applied to HCW treatment.

- Some biological treatment systems use enzymes to speed up the destruction of organic waste containing pathogens.
- Composting and vermiculture (digestion of organic wastes through the action of worms) are biological processes and have been used successfully to decompose hospital kitchen waste, as well as other organic digestible waste (Mathur, Verma & Srivastava, 2006) and placenta waste.
- The natural decomposition of pathological waste through burial.

8.2.4 Mechanical Processes

Mechanical treatment processes include several shredding, grinding, mixing and compaction technologies that reduce waste volume, although they cannot destroy pathogens. Mechanical processes are not stand-alone HCW-treatment processes, but supplement other treatment methods.

- Mechanical destruction can render a waste unrecognizable and can be used to destroy needles and syringes (depending on the type of shredding).
- In the case of thermal or chemical treatment processes, mechanical devices such as shredders and mixers can also improve the rate of heat transfer or expose more surface area of waste to waste treatment.
- Mechanical devices used to prepare wastes before other forms of waste destruction add significantly to the level of management and maintenance required to treat HCW safely and efficiently.

Unless shredders, mixers and other mechanical devices are an integral part of a closed treatment system, they should not be used before the incoming HCW is disinfected, otherwise, workers are at an increased risk of being exposed to pathogens in aerosols released into the environment by mechanical destruction of untreated waste bags. If mechanical processes are part of a closed system, the technology should be designed in such a way that the air in and from the mechanical process is disinfected before being released to the surroundings.

8.3 Treatment Technologies

The advantage and disadvantages of the following options for treatment of HCW are presented in **ANNEX B 5**.

8.3.1 Steam Treatment Technology

A. Autoclave

Autoclaves are capable of treating a range of infectious waste, including cultures and stocks, sharps, materials contaminated with blood and limited amounts of fluids, isolation and surgery waste, laboratory waste (excluding chemical waste) and “soft” waste (including gauze, bandages, drapes, gowns and bedding) from patient care. Volatile and semi-volatile organic compounds, chemotherapeutic waste mercury, other hazardous chemical waste and radiological waste should not be treated in an autoclave.

An autoclave consists of a metal vessel designed to withstand high pressures, with a sealed door and an arrangement of pipes and valves through which steam is introduced into, and removed from, the vessel. Air is an effective insulator and a principal factor in determining the efficiency of steam treatment. Removal of air from the autoclave is essential to ensure penetration of heat into the waste. Unlike instrument sterilization autoclaves, waste-treatment autoclaves must treat the air that is removed at the start of the process to prevent the release of pathogenic aerosols. This is usually done by treating the air with steam or passing it through a high-efficiency particulate air (HEPA) filter before it is released.

The operation of autoclaves requires the proper combination of temperature/pressure and exposure time to achieve disinfection, a minimum recommended temperature–exposure time criterion of for example 121°C for 30 minutes was suggested. However, the effective penetration of steam and moist heat depends on many factors, including time, temperature/pressure, process sequence, load size, stacking configuration and packing density, types and integrity of bags or containers used, physical properties of the materials in the waste (such as bulk density, heat capacity and thermal conductivity), the amount of residual air and the moisture content in the waste (Lemieux et al., 2006). Regular validation tests using biological indicators should be performed at periodic intervals (typically, every week, every 40 hours of use, or once a month, depending on usage).

As an added check, color changing chemical indicators, such as strips that contain thermochromic agents (chemicals that change color when they reach a given temperature) or integrators (indicators that respond to both time and temperature) can be used with each waste load to document that the required temperature has been achieved.

Box 29: General considerations in the use of autoclave

The following must be considered in using autoclave:

- Autoclaves are generally not used for large anatomical remains (body parts), because it is difficult to determine beforehand the time and temperature parameters needed to allow full penetration of heat to the center of the body part. With sufficient time and temperature, it is technically possible to treat small quantities of human tissue, but ethical, legal, cultural, religious and other considerations may preclude their treatment.
- Volatile and semi-volatile organic compounds, chemotherapeutic waste, mercury, other hazardous chemical waste, and radiological waste should not be treated in an autoclave.
- Large and bulky bedding material, large animal carcasses, sealed heat-resistant containers and other waste loads that impede the transfer of heat should be avoided.
- If liquids such as blood bags or urine bags are to be sterilized, the sterilization process and time have to be adapted. The Robert Koch Institute recommends treating prions, which cause Creutzfeld–Jacob disease, at 134°C for 60 minutes because of their exceptional resistance.



Reference:

Global Healthcare Waste Project, Module 15: Non-Incineration Treatment and Disposal of Healthcare Waste:
https://www.who.int/water_sanitation_health/facilities/waste/module15.pdf?ua=1

Box 30: Treatment of wastes from medical laboratories

In laboratories, decontamination of wastes and their ultimate disposal are closely interrelated. In terms of daily use, few if any contaminated materials will require actual removal from the laboratory or destruction. Most glassware, instruments and laboratory clothing will be reused or recycled. The overriding principle is that all infectious materials should be decontaminated, autoclaved, or incinerated within the laboratory. (WHO, Biosafety).

- Steam autoclaving is the preferred method for all decontamination processes. Materials for decontamination and disposal should be placed in containers, e.g., autoclavable plastic bags, that are color-coded according to whether the contents are to be autoclaved and/or incinerated.
- Non-contaminated (non-infectious) waste that can be reused or recycled or disposed of as general, "household" waste.
- Contaminated (infectious) "sharps" – hypodermic needles, scalpels, knives, and broken glass; these should always be collected in puncture-proof containers fitted with covers and treated as infectious.
- No pre-cleaning should be attempted of any contaminated (potentially infectious) materials to be autoclaved and reused. Any necessary cleaning or repair must be done only after autoclaving or disinfection.
- All contaminated (potentially infectious) materials should be autoclaved in leakproof containers, e.g., autoclavable, color-coded plastic bags, before disposal.
- Discard containers, pans, or jars, preferably unbreakable, should be placed at every workstation. When disinfectants are used, waste materials should remain in intimate contact with the disinfectant (i.e., not protected by air bubbles) for the appropriate time, according to the disinfectant used.

B. Autoclave with Integrated Shredders

This is sometimes referred as advanced autoclave, hybrid autoclave, or advanced steam treatment technology. This system functions as an autoclave but combined with various mechanical processing before, during, or after steam treatment. The purpose is to improve the transfer of heat into the waste, achieving more uniform heating of the waste, rendering the waste unrecognizable and/or making the treatment system continuous process. Volatile and semi-volatile organic compounds, chemotherapeutic waste mercury, other hazardous chemical waste and radiological waste should not be treated thru this technology.

8.3.2 Microwave Treatment Technology

Microwave technology is essentially a steam-based process where treatment occurs through the action of moist heat and steam generated by microwave energy. Water contained in the waste is rapidly heated by microwave energy at a frequency of about 2450 MHz and a wavelength of 12.24cm. In general, microwave-treatment systems consist of a treatment area or chamber into which microwave energy is directed from a microwave generator (magnetron). Generally, 2 to 6 magnetrons are used with an output of about 1.2 kW each. Some systems are designed as batch processes and others are semi-continuous (Emmanuel, 2001; Emmanuel & Stringer, 2007).

The types of waste commonly treated in microwave systems are identical to those treated in autoclaves: cultures and stocks, sharps, materials contaminated with blood and body fluids, isolation and surgery waste, laboratory waste (excluding chemical waste) and soft waste (e.g., gauze, bandages, gowns and bedding) from patient care. One microwave system has been successfully tested with animal waste and can potentially be used to treat pathological waste such as tissues (Devine et al., 2007). Volatile and semi-volatile organic compounds, chemotherapeutic waste mercury, other hazardous chemical waste and radiological waste should not be treated in a microwave. A fully enclosed microwave unit can be installed in an open area and, with a HEPA filter to prevent the release of aerosols during the feed process, odor is somewhat reduced, except in the immediate vicinity of the microwave unit.

8.3.3 Dry Heat Treatment Technology

In dry-heat processes, heat is applied without adding steam or water. Instead, the waste is heated by conduction, natural or forced convection, or thermal radiation. In forced convection heating, air heated by resistance heaters or natural gas is circulated around the waste in the chamber. In some technologies, the hot walls of the chamber heat the waste through conduction and natural convection. Other technologies use radiant heating by means of infrared or quartz heaters.

Circulating hot-air ovens have been used to sterilize glassware and other reusable instruments for many years. This concept of dry-heat treatment has been applied to treatment of infectious health waste more recently. As a general observation, dry-heat processes use higher temperatures and longer exposure times than steam-based processes. They are not commonly used in large-scale facilities and usually treat only small volumes. *Bacillus atrophaeus* spores are known to be resistant to dry heat and are commonly used as a microbiological indicator to measure the effectiveness of dry-heat technologies. Volatile and semi-volatile organic compounds, chemotherapeutic waste mercury, other hazardous chemical waste and radiological waste should not be treated through this technology.

8.3.4 Chemical Treatment Technology

8.3.4.1 Chemical Disinfection

Used routinely in HCFs to destroy or inactivate microorganisms on medical equipment and on floors and walls, is now being extended to the treatment of HCW. This treatment usually results in disinfection rather than sterilization. Chemical disinfection is most suitable for treating liquid waste such as blood, urine, stools, or hospital sewage.

Manual systems using chemical disinfection are not regarded as a reliable method for treating waste. Chemical disinfection is usually carried out on HCF premises; however, commercial, self-contained, and fully automatic systems have recently been developed for HCW treatment and are being operated away from medical centers at industrial zones. Subsequently, the disinfected waste requires specialized disposal.

Solid, even highly hazardous, HCWs, including microbiological cultures and sharps, may also be disinfected chemically, with the following limitations:

- Shredding or milling of waste is usually necessary before disinfection. The shredder is often the weak point in the treatment chain, being susceptible to mechanical failure or breakdown. Internal shredding of waste before disinfection plus subsequent compacting can reduce the original waste volume by 60–90%, depending on the type of equipment used. Shredding of solid HCW before or during disinfection should be done in a closed system to avoid release of pathogens into the air.
- Chemical treatment of solid infectious waste is potentially problematic because of the variability of chemical efficacy based upon load characteristics, and the generation of toxic liquid waste. Powerful disinfectants are required, which can be hazardous and should be used only by well-trained and adequately protected personnel.
- Disinfection efficiency depends on the operational conditions within treatment equipment. The speed and efficiency of chemical disinfection

will depend on operational conditions, including the following:

- kind of chemical used;
 - amount of chemical used;
 - contact time between disinfectant and waste;
 - extent of contact between disinfectant and waste;
 - organic load of the waste; and
 - operating temperature, humidity, pH.
- Only the surface of intact solid waste items will be disinfected.

In application of chemical disinfection, the following must be considered by the HCF:

- The types of chemicals used for disinfection of HCW are mostly chlorine compounds, aldehydes, lime-based powders or solutions, ozone gas, ammonium salts and phenolic compounds. Formaldehyde and ethylene oxide are no longer recommended for waste treatment due to significant hazards related to their use.
- Studies showed that chlorine-based technologies using sodium hypochlorite and chlorine dioxide as well as its by-products in wastewater may possibly have long-term environmental effects.
- Non-chlorine-based technologies are quite varied in the way they operate and the chemical agents they employ. Others use peroxyacetic acid, ozone gas, lime-based dry powder, acid and metal catalyst or biodegradable disinfectants. Occupational and safety exposures shall be monitored when using the chemical process.
- Some disinfectants are effective in killing or inactivating specific types of microorganisms, and others are effective against all types. It is therefore important to know the identity of the target microorganisms to be destroyed.
- Users of chemical disinfectants should consider their stability and shelf life. Some disinfectants are stable for several years and can remain effective for months after opening the container. Other disinfectants degrade quickly.
- Powerful disinfectants are often hazardous and toxic, and many are harmful to skin and mucous membranes. Users should therefore be aware of their physiological effects and wear protective clothes, including gloves and protective eyeglasses or goggles. Disinfectants are also aggressive to certain building materials and should be handled and stored according to manufacturers' instructions.

- Microbial resistance to disinfectants has been investigated, and it is possible to list the major groups of microorganisms from most to least resistant as follows:
 - bacterial spores;
 - mycobacteria;
 - hydrophilic viruses;
 - lipophilic viruses;
 - vegetative fungi and fungal spores; and
 - vegetative bacteria.
- In planning the use of chemical disinfection, requirements for the eventual disposal of the residues should be carefully considered. Improper disposal could give rise to serious environmental problems.

8.3.4.2 Alkaline Hydrolysis

Alkaline hydrolysis or digestion is a process that converts animal carcasses, human body parts and tissues into a decontaminated aqueous solution. The alkali also destroys fixatives in tissues and various hazardous chemicals, including formaldehyde, glutaraldehyde, and chemotherapeutic agents.

The technology is designed for tissue wastes including anatomical parts, organs, placenta, blood, body fluids, specimens, human cadavers, and animal carcasses. The process has been shown to destroy prion waste. The by-products of the alkaline digestion process are biodegradable mineral constituents of bones and teeth (which can be crushed and recovered as sterile bone meal) and an aqueous solution of peptide chains, amino acids, sugars, soaps, and salts.

The technology uses a steam-jacketed, stainless-steel tank and a basket. After the waste is loaded in the basket and into the hermetically sealed tank, alkali (sodium or potassium hydroxide) in amounts proportional to the quantity of tissue in the tank is added, along with water. The contents are heated to between 110°C and 127°C or higher and stirred. Depending on the amount of alkali and temperature used, digestion times range from six to eight hours. Alkaline hydrolysis units have been designed to treat from 10 to 4500kg per batch. The technology has been approved for the destruction of prion waste when treated for at least six hours (European Commission Scientific Steering Committee, 2003; Thacker, 2004).

8.3.5 High Temperature Processing Technologies

8.3.5.1 Incineration

Incineration is a high-temperature, dry oxidation process that reduces organic and combustible waste to inorganic, incombustible matter, and results in a significant reduction of waste volume and weight. High-heat thermal processes take place at temperatures from about 200°C to more than 1000°C. They involve the chemical and physical breakdown of organic material through the processes of combustion, pyrolysis, or gasification.

In accordance with the Stockholm Convention, the best available technology (BAT) should be used to achieve an emission of lower than 0.1ng TEQ/m³ of dioxins and furans.⁶ It is stated that primary measures for incinerators are two burning chambers (850°C/1100°C), auxiliary burner, two seconds' residence time of air in the second chamber, sufficient oxygen content, and high turbulence of exhaust gases. The primary measures described here should be a minimum standard. By applying primary measures, a performance around 200ng TEQ/m³ of dioxins and furans can be achieved. This minimum standard should be followed by an incremental improvement approach, with which the requirements of the Stockholm Convention can be reached. In order to achieve emissions lower than 0.1ng TEQ/m³, additional flue gas treatment systems are needed (secondary measures). These may be comparatively expensive for small and medium-sized incinerators, and this should be taken into consideration at the planning stage. Furthermore, air filters and wastewater resulting from the filtering processes are considered as hazardous waste and need to be handled accordingly.

There are few small and medium-sized incinerators available on the market which operate in accordance with the Stockholm Convention. See **ANNEX A 7** for the flow diagram of incineration process with flue gas.

High-tech incinerators require reliable controls of combustion parameters, a flue gas cleaning system (dust removal, ceramic filters, cyclonic scrubbers, and electrostatic precipitators) and wastewater treatment.

Burning HCW without flue gas treatment releases a wide variety of pollutants into the atmosphere, according to the composition of the waste. These pollutants may include particulate matter such as fly ash, heavy metals (arsenic, cadmium, chromium, copper, mercury, manganese, nickel, and lead), acid gases (hydrogen chloride, hydrogen fluoride, Sulphur dioxides, nitrogen oxides), carbon monoxide, and organic compounds (including dioxins and furans, benzene, carbon tetrachloride, chlorophenols, trichloroethylene, toluene, xylenes, trichlorotrifluoroethane, polycyclic aromatic hydrocarbons, vinyl chloride).

If medical waste is incinerated in conditions that do not constitute best available

⁶ TEQ or toxic equivalents report the toxicity-weighted masses of mixtures of polychlorinated-p-dibenzodioxins (PCDDs) and polychlorinated dibenzofurans (PCDFs) and polychlorinated biphenyls (PCBs).

techniques or best environmental practices, there is potential for the release of dioxins and furans in relatively high concentrations. Dioxins and furans are bio-accumulative and toxic. Pathogens can also be found in solid residues and in the exhaust gases and particulates of poorly designed and badly operated incinerators. In addition, the bottom ash residues can be contaminated with dioxins, leachable organic compounds, and heavy metals and should be treated as hazardous waste.

Box 31: Small-scale incineration

Small-scale incinerators are designed to meet an immediate need for public health protection where there is no access to more sophisticated technologies. This involves a compromise between the environmental impacts from controlled combustion and an overriding need to protect public health if the only alternative is indiscriminate dumping. As far as possible, a small-scale facility should avoid burning PVC plastics and other chlorinated waste.

If small-scale incinerators are the only option available, the best practices possible should be used, to minimize operational impacts on the environment. Best practices in this context are (Batterman, 2004):

- *Effective waste reduction and segregation, ensuring only the smallest quantities of combustible waste types are incinerated;*
- *An engineered design with sufficient residence time and temperatures to minimize products of incomplete combustion;*
- *Siting incinerators away from health care buildings and residential areas or where food is grown;*
- *Construction using detailed engineering plans and materials to minimize flaws that may lead to incomplete destruction of waste and premature failures of the incinerator;*
- *A clearly described method of operation to achieve the desired combustion conditions and emissions;*
- *Periodic maintenance to replace or repair defective components (including inspection, spare parts inventory and daily record keeping);*
- *Improved training and management, possibly promoted by certification and inspection programs for operators, the availability of an operating and maintenance manual, visible management oversight, and regular maintenance schedules.*

8.3.5.2 Pyrolysis and gasification

Pyrolysis and gasification processes operate with substoichiometric air levels. It is the thermal decomposition of HCW in the absence of supplied molecular oxygen in the destruction chamber in which the said HCW is converted into gaseous, liquid, or solid form. Pyrolysis can handle the full range of HCW. Waste residues may be in form of greasy aggregates or slugs, recoverable metals, or carbon black. These residues are disposed of in a landfill.

8.3.6 Emerging Technologies

Developing and emerging technologies should be carefully evaluated before selection for routine use, because most do not have demonstrable track record in HCW application.

8.3.6.1 Ozone

Ozone (O₃) can be used for disinfecting waste. Ozone gas is a strong oxidizer and breaks down easily to a more stable form (O₂). Ozone systems require shredders and mixers to expose the waste to the bactericidal agent. Ozone has been used for water treatment and air purification. At concentrations greater than 0.1 ppm, ozone can cause eye, nose, and respiratory tract irritation. As with other chemical treatment technologies, regular tests should be conducted to ensure that the microbial inactivation standard is met.

8.3.6.2 Plasma Pyrolysis

Plasma pyrolysis makes use of an ionized gas in the plasma state to convert electrical energy to temperatures of several thousand degrees using plasma arc torches or electrodes. The high temperatures are used to pyrolyze waste in an atmosphere with little or no air.

8.3.6.3 Promession

Promession is a new technology that combines a mechanical process and the removal of heat to destroy anatomical waste. It involves cryogenic freeze-drying using liquid nitrogen and mechanical vibration to disintegrate human remains into powder before burial. The process speeds up decomposition, reduces both mass and volume, and allows the recovery of metal parts.

8.3.6.4 Pyroclave

The process involved in a pyroclave is a combination of pyrolysis and autoclave. The pyroclave can disinfect and reduce the mass and volume of the medical wastes by 95%. Like pyrolysis, wastes are thermally decomposed without direct contact to fire and without the presence of oxygen. HCW is placed inside a sealed rotating chamber. The pyroclave operates in intense heat (up to 1,200°C) to carbonize the HCW. A synthesized gas called "syngas", produced by the intense heat and decomposition process, is recycled and fed into the burners, thereby serving as added fuel to continue the process and help boost combustion. Through this process, disinfection, carbonization, and decomposition can be accomplished.

8.3.6.5 Superheated steam

Superheated steam at 500°C can be used to break down infectious, hazardous chemical or pharmaceutical wastes. The vapors are then heated further in a steam reforming chamber to 1500°C. This technology is expensive, and – like incineration – requires pollution control devices to remove pollutants from the exhaust gas.

8.4 On-site HCW Treatment Facilities

If the HCF opt to operate its own HCW treatment facility, the following factors must be considered for the location of the treatment facilities:

- Safe transfer routes must be provided from the storage area to the treatment facility;
- The HCW treatment facilities must be located within the HCF. However, the area must be located away from the dietary section, patient rooms, laboratories, hospital function/operation rooms or any public access areas;
- The facilities should be located in a way that it does not produce nuisance such as odor, noise, the visual impact of HCW operations on patients and visitors;
- Public access and security are provided;
- Consider the proximity of the treatment facility to the temporary or central storage;
- Be strategically placed so as not to cause traffic problems in the entry and exit of vehicles;
- Consider the volume of waste generated by the HCF when it comes to the size of the treatment facility;
- Be protected from rain, strong winds, floods, etc.;
- Have elevated, concrete finish flooring and with waterproofing, adequately sloped for easy cleaning;
- Have a good drainage system and connected to a WWTP.
- Have continuous water supply for cleaning purposes.
- Have locking device to prevent access by unauthorized persons.
- Be inaccessible to animals, insects, and birds.
- Have adequate ventilation and lighting
- Have supplies of cleaning implements (e.g., hose with spray nozzle, scrubber with long handle, disinfectant, protective clothing, waste bags or bins) and fire-fighting equipment/devices located conveniently close to the storage area.
- Have space allowances needed by workers to maneuver safely around the treatment facility.
- Have floors, walls, and ceilings that are clean at all times.

- Have a warning sign posted in a strategic place: "CAUTION: TREATMENT AREA: UNAUTHORIZED PERSONS KEEP OUT."

8.5 HCW Disposal

8.5.1 Encapsulation

Encapsulation involves filling containers with waste, adding an immobilizing material, and sealing the containers. A sample schematic diagram is shown in **ANNEX E 6**. The process uses either cubic boxes made of high-density polyethylene or metallic drums, which are three-quarters filled with sharps or chemical or pharmaceutical residues. The containers or boxes are then filled up with a medium such as plastic foam, bituminous sand, and cement mortar. After the medium has dried, the containers are sealed and disposed of in landfill.

This process, where the encapsulation materials are available, is appropriate for establishments for the disposal of sharps and chemical or pharmaceutical residues. Encapsulation alone is not recommended for non-sharps waste but may be used in combination with treatment of such waste. The main advantage of the process is its effectiveness in reducing the risk of scavengers gaining access to the hazardous HCW.

8.5.2 Inertization – Stabilization/Solidification

Inertization involves mixing waste with cement and other substances before disposal to minimize the risk of toxic substances contained in the waste migrating into surface water or groundwater. Inertization can be by the process of stabilization or solidification. Stabilization refers to the chemical changes of the hazardous substances in the waste while solidification means physical immobilization of the hazardous substances to reduce the vaporization or leaching to the environment.

This process is especially suitable for pharmaceuticals and for incineration ashes with a high metal content (in this case, the process is also called "stabilization"). For the inertization of pharmaceutical waste, the packaging should be removed, the pharmaceuticals ground, and a mixture of water, lime and cement added. A homogeneous mass is formed, and cubes or pellets are produced on-site. Subsequently, these can be transported to a suitable storage site. Alternatively, the homogeneous mixture can be transported in liquid state to a landfill and poured onto the surface of previously landfilled municipal waste, then covered with fresh municipal waste.

The process is reasonably inexpensive and can be performed using relatively unsophisticated mixing equipment. Other than personnel, the main requirements are a grinder or road roller to crush the pharmaceuticals, a concrete mixer and supplies of cement, lime, and water.

8.5.3 Sharps Pit/Concrete Vault

This method is especially suitable for the disposal of used sharps and syringes. The collected safety boxes filled with used sharps and needles will be deposited inside the concrete vault. Refer to **ANNEX E 7** for a sample concrete vault design.

Box 32: Construction of sharps pit/concrete vault

The following shall be observed when constructing the concrete vault:

- The site is isolated and at least 150 meters away from the water supply sources and dwelling units.
- Dig a pit (minimum size of 1m x 1m x 1.8m depth) enough to accommodate sharps/syringes for an estimated period of time without reaching the groundwater level.
- Construct concrete walls and slabs of pit.
- Provide slab with opening/manhole for easy deposition of collected sharps and syringes. Manhole shall be extended a few centimeters above soil surface to overcome infiltration of surface water.
- Install security fence around the site with signage.



8.5.4 Placenta Pit

In many communities, burying placentas is an important ritual and one option for disposal. If it is done safely, burial can protect the community from pathogens while respecting cultural norms and religious traditions. The disposal of the placenta can use concrete pits. The process of biodegradation in the pit can destroy pathogenic microorganisms as the waste is subjected to changes in temperature, pH, and a complex series of chemical and biological reactions. The degradation processes in a pit are anaerobic, with some aerobic decomposition in the upper layers where oxygen is available for aerobic bacteria. The waste should not be treated with chemical disinfectants such as chlorine before being disposed of, because these chemicals destroy the microorganisms that are important for biological decomposition.

In selecting the location of the placenta pit, the following should be considered:

- Should be as far away as possible from publicly accessible areas and from hygienically critically areas (e.g., water wells, kitchens);
- Placenta pits should not be built too close to buildings due to possible odors;
- A safety distance of at least 1.5 meters from the bottom of the pit to the groundwater level is recommended; and

- Placenta pits are not recommended in sites where the water table is near the surface or in areas prone to flooding.

The dimensions of the pit will be context specific and will depend on the average number of births and infiltration rate of the soil. In principle, allow 0.5 liters of soil infiltration per placenta, and a maximum of 5 liters of total space per placenta if all the bloody liquids are collected and no infiltration is occurring.

It is recommended that two placenta pits are built so that the second one is available as soon as the first is filled. Once a pit is filled up, it should be closed. Any sealed pits should be marked, and their locations recorded. However, it may be possible to reopen pits after enough time has passed and the material has been degraded. When pits are reopened, it may be necessary to remove some of the degraded material.

Refer to **ANNEX E 8** for a sample placenta pit design.

8.5.5 Safe On-site Burial at HCF Located in Remote Areas

Safe burial of HCW within the HCF as a disposal method is applicable only to treated infectious waste, sharps waste, pathological and anatomical waste, small quantities of encapsulated/inertized solid chemical and pharmaceutical wastes. Safe burial may be implemented but should be considered transitional, interim solution.

Safe burial of HCW shall only be allowed in the following situations:

- HCF is located in a remote and far-flung area;
- HCF does not have access to TSD facilities;
- HCF is located in a local government unit (LGU) with an income classification of 5th or 6th Class;
- HCF located in 1st to 4th Class LGU has available area within the HCF premises (only pathological, anatomical, expired drugs and sharps wastes can be buried);
- Safe burial of HCW within the HCF premises is the only viable option at a specific period of time, e.g., temporary refugee encampments and areas experiencing exceptional hardship.

The following shall be the characteristics for the safe burial site:

- Not located in flood prone areas;
- Downhill or down-gradient from any nearby wells and about 50 meters away from any water body such as rivers or lakes to prevent contaminating water source; new water wells should not be dug near the disposal pit;

- Bottom of the pit located at least 1.5 meters above groundwater level;
- Secured (e.g., fenced with warning signs); accessible only to authorized personnel;
- Lined with a material of low permeability, such as clay or HPDE, to prevent pollution of shallow groundwater that may subsequently reach nearby wells;
- Allow only hazardous HCW to be buried. If general HCW are also buried on the premises, available space would be quickly filled-up;
- Managed as a landfill, with each layer of waste covered with a layer of earth to prevent odor, as well as to prevent proliferation of rodents and insects; and
- Larger quantities (<1kg) of chemical wastes should not be buried at one time; however, burying small quantities occasionally is less likely to create adverse pollution.

Refer to **ANNEX E 9** for a sample on-site waste burial pit design. The HCF shall keep a permanent record of the size and location of all their on-site burial pits to prevent construction workers, builders, and others from digging in those areas in the future. The safe burial of waste depends critically on rational operational practices. It shall be noted that safe on-site burial is practicable only for relatively limited period, about 1 to 2 years, and for relatively small quantities of waste, about 5 to 10 tons in total. When these conditions have been exceeded, a long-term solution will be needed.

8.5.6 Sanitary Landfill Facility

HCW that is properly treated with the applicable technology as stated in this Manual can be disposed in a sanitary landfill but must not be mixed with the municipal wastes. Dedicated cells for the treated HCW must be provided in the sanitary landfill. To allow the disposal of the HCW to the sanitary landfill, the following must be met:

- The waste treatment facility/system for the treatment of infectious and sharps wastes passed the standards for microbial inactivation test; and the properly treated HCW passed the spore strip test;
- The waste treatment facility/system has a valid CPR from the DOH-Bureau of Health Devices and Technology (BHDT), and;
- The waste treatment facility is an EMB-registered TSD facility.

A sanitary landfill is an engineered method designed to keep the waste isolated from the environment. Appropriate engineering preparations and corresponding permits from DENR shall be completed before the site is allowed to accept waste. There shall be a trained staff present on-site to control and manage the operations. The landfill shall:

- Be accessible to site and working areas for easy passage of delivery access;
- Have landfill personnel capable of effective control of daily operations;
- Divide the site into manageable phases, which are appropriately prepared, before disposal of wastes;
- Have adequate sealing of the base and sides to minimize the movement of wastewater (leachate);
- Have adequate mechanisms for leachate collection and treatment systems;
- Have an organized deposit of waste in a small area, allowing waste to be spread, compacted, and covered daily;
- Have surface water collection trenches around site boundaries;
- Have a construction of a final cover to minimize rainwater infiltration when each phase of the landfill is completed.

Certain types of HCW, such as anatomical waste, will still have an offensive visual impact after treatment and preferably should not be landfilled. Disposing of such waste in landfill may also be culturally or religiously unacceptable in many countries. Such wastes should be placed in approved burial grounds or cremated. If this is not possible, these wastes could be placed in containers or rendered unrecognizable before disposal.

Table 5: Applications of treatment and disposal methods for specific HCW categories

Category of HCW	Treatment/Disposal Method Options
Sharps	<ul style="list-style-type: none"> • Disinfection: Autoclave, Microwave technology, Chemical disinfection • Mechanical shredding: On-site mechanical needle cutters or electric needle destroyers • Encapsulation in cement blocks • Sharps pits/Concrete vaults
Anatomical waste, pathological waste, placenta waste and contaminated animal carcasses	<ul style="list-style-type: none"> • Burning in crematoria or specially designed incinerators • Alkaline digestion, especially for contaminated tissues and animal carcasses • Promession • Interment (burial) in cemeteries or special burial sites • Placenta waste is composted or buried in placenta pits designed to facilitate natural biological decomposition.
Pharmaceutical waste	<ul style="list-style-type: none"> • Return to the original supplier (preferred option) • Encapsulation • Chemical decomposition in accordance with the manufacturer's recommendations if chemical expertise and materials are available; • Dilution in large amounts of water and discharge into a sewer for moderate quantities of relatively mild liquid or semi-liquid pharmaceuticals, such as solutions containing vitamins, cough syrups, intravenous solutions and eye drops and harmless liquids such as intravenous fluids.

Category of HCW	Treatment/Disposal Method Options
	<ul style="list-style-type: none"> • Incineration in kilns equipped with pollution-control devices designed for industrial waste and that operate at high temperatures; • Dilution and sewer discharge for relatively harmless liquids such as intravenous fluids (salts, amino acids, glucose). • Sanitary landfill for non-hazardous pharmaceutical waste
Cytotoxic Waste	<ul style="list-style-type: none"> • Incineration at high temperatures with gas-cleaning equipment • Chemical degradation in accordance with manufacturers' instructions. • Alkaline hydrolysis • Encapsulation or Inertization may be considered as a last resort • Return to the original supplier (preferred option)
Chemical Waste	<ul style="list-style-type: none"> • Large amounts of chemical waste should not be buried, because they may leak from their containers, overwhelm the natural attenuation process provided by the surrounding waste and soils, and contaminate water sources. • Encapsulation. (Large amounts of chemical disinfectants should not be encapsulated, because they are corrosive to concrete and sometimes produce flammable gases) • Where allowed by local regulations, non-recyclable, general chemical waste, such as sugars, amino acids and certain salts, may be disposed of with municipal waste or discharged into sewers. • An option for disposing of hazardous chemicals is to return them to the original supplier, who should be equipped to deal with them safely • Sanitary landfill (for small quantities only)
Waste containing heavy metals	<ul style="list-style-type: none"> • Wastes containing mercury or cadmium should not be burned or incinerated. Cadmium and mercury volatilize at relatively low temperatures and can cause atmospheric pollution. • If none of the above options are feasible, the wastes would have to go to a disposal or storage site designed for hazardous industrial waste. • Send back the waste to the suppliers of the original equipment, with a view to reprocessing or final disposal
Radioactive Waste	<ul style="list-style-type: none"> • The treatment and disposal of radioactive waste is generally under the jurisdiction of PNRI. • Return to supplier • "Decay in storage", which is the safe storage of waste until its radiation levels are indistinguishable from background radiation; a general rule is to store the waste for at least 10 times the half-life of the longest-lived radionuclide in the waste. • Long-term storage at an authorized radioactive waste disposal site. • It is not appropriate to disinfect radioactive solid waste by wet thermal or microwave procedures • Disposable syringes containing radioactive residues should be emptied in a location designated for the disposal of radioactive liquid waste. Syringes should then be stored in a sharps container to allow decay of any residual activity, before normal procedures for disposal of syringes and needles are followed. • Higher-level radioactive waste of relatively short half-life (e.g., from iodine-131 therapy) and liquids that are immiscible with

Category of HCW	Treatment/Disposal Method Options
	<p>water, such as scintillation-counting residues and contaminated oil, should be stored for decay in marked containers, under lead shielding, until activities have reached authorized clearance levels.</p> <ul style="list-style-type: none"> • Radioactive waste resulting from cleaning-up operations after a spillage or other accident should be retained in suitable containers, unless the activity is clearly low enough to permit immediate discharge. • Solid radioactive waste, such as bottles, glassware, and containers, should be destroyed before disposal to avoid reuse by the public

Box 33: Overview of treatment and disposal of HCW in primary care facilities

Treatment of wastes mainly aims at reducing direct exposure less dangerous to humans, at recovering recyclable materials, and at protecting the environment. For wastes from the primary care facilities, the main aim is to disinfect infectious waste, to destroy disposable medical devices, in particular used syringe needles, which should not be reused, or at least to render them inaccessible or sterile prior to plastic reprocessing. The table below shows the different possible treatment of different HCW.

Treatment/Disposal Options	Non-plastic Infectious Waste	Anatomical Waste	Sharps Waste	Pharmaceutical Waste	Chemical Waste
Waste Burial	Yes ¹	Yes ¹	Yes ¹	Small quantities	Small quantities
Sharp pit	No	No	Yes ¹	Small quantities	No
Placenta pit	No	Yes ¹	No	No	No
Encapsulation	No	No	Yes	Yes	Small quantities
Inertization	No	No	No	Yes	No
Low temp burning (< 800°C)	Yes (interim solution)	Yes (interim solution)	No	No	No
Med temp burning (800 – 1000°C)	Yes	Yes	Yes	No	No
High temp burning (> 1000°C)	Yes	Yes	Yes	Small quantities	Small quantities
Steam autoclave	Yes	No	Yes	No	No
Microwave	Yes	No	Yes	No	No
Chemical	Yes	No	Yes	No	No
Discharge to Sewer	No	No	No	Only non-hazardous	Small quantities
Others				Return expired drugs to supplier	Return unused chemicals to supplier

Note: ¹ Waste should be disinfected first

Source: Management of Solid Health-care Waste at Primary Health-Care Centers (WHO, 2005)

Box 34: Management of wastes from home care services

Home care wastes are typically the type of wastes normally encountered when administering home health care include needles, syringes, lancets, other sharp objects, soiled bandages, gauze, disposable sheets, tubings, and used medical gloves. The improper disposal of contaminated sharps is a serious safety concern for garbage collectors and landfill workers. If improperly thrown in trash bags along with regular trash, these sharps can puncture the bags and cause injury.

The disposal of clinical waste in a patient's home, where the patient is treated by a community nurse or a health care professional, is the responsibility of the nurse/health care professional giving the treatment. The health care professional / nurse needs to ask permission from the homeowner prior to disposing of waste into their rubbish bin.

It is important that hospitals and other HCFs shall provide instructions to the family and relatives of the patient prior to approval for homecare, the basic information on homecare waste management and disposal. Further, homecare waste management and disposal shall be monitored by the local health authorities in the area. The following must be observed for the proper management and disposal of HCW from home care:

- Dispose lancets, syringes and other sharp objects separately by placing in hard plastic or metal containers with screw-on or tightly secured lid. Many containers found in the household will do.
- Before disposal the tightly sealed lead must be reinforced with heavy-duty tape and labelled "NOT FOR RECYCLING".
- Do not place sharps in glass containers and those intended for re-use or recycling. Containers should have a small opening so that no one else is able to stick their hand into it.
- Do not recap, purposely bend, break, or otherwise manipulate needles before inserting them into the disposal container.
- Sharps should be disposed once container is three-quarters full. Be sure to keep all containers with discarded sharps of reach of children and pets. Drop all parts into the container. Before disposal the tightly sealed lead must be reinforced with heavy-duty tape and labelled "NOT FOR RECYCLING".
- Other hazardous infectious materials such as soiled bandages, gloves, disposable sheets must be placed in securely fastened yellow plastic bags prior to disposal.
- If the waste is classified as non-hazardous, (non-infectious) and as long as it is double bagged in a small translucent/white bag and sealed, it is acceptable for the waste to be disposed of with household waste. This is usually the case with plasters, small dressings, sanitary towels and incontinence products.
- If the waste is classified as hazardous in the patient's home, the health care professional can remove that waste and transport it in approved containers (i.e. rigid, leak proof, sealed, secured etc.) and take it to the nearest HCF with HCW disposal units. The caregivers who are family members can also do the same procedure to dispose of hazardous and infectious waste ensuring always to follow the required type of containers.

Source: Adapted from "Disposal Tips for Home Healthcare" (USEPA, 1998)

Box 35: Management of wastes from immunization campaign activities

Immunization activities generate sharps and infectious non-sharp wastes that should be properly managed on-site to avoid or reduce its negative health impacts on the community and the personnel working.

Waste Segregation and Packaging

- Always segregate sharps from non-sharps at the source
- Immediately after use, discard entire syringe with needle into a safety box without recapping needles
- Put safety boxes into plastic bags closed hermetically when full to avoid any leakage during transportation. Mark the bag clearly.
- Put empty vials into waste containers with plastic lining to avoid leakage. Seal/mark clearly when full.

Waste Treatment and Final Disposal

For Sharps (needles with syringe)

- Prepare sufficient number of sharps safety boxes for the day;
- Discard entire syringe and needle immediately after vaccination in safety box without recapping;
- When the sharps safety box is three-quarters full, put it aside and make sure that waste handlers close, seal it with adhesive tape and mark it before putting it in a plastic bag.
- Place plastic bags carefully in storage area or take to disposal system if ready to process immediately.

For Infectious non-sharps (empty or expired vials)

- Prepare sufficient numbers of waste containers with plastic lining for the day;
- Put empty vaccine flasks and cotton swabs in the waste container;
- Once nearly full, put it aside and make sure that waste handlers close, seal it with adhesive tape and mark it before taking it away to the storage or disposal area

Source: Management of wastes from immunization campaign activities (WHO, 2004)

Box 36: Minimum approach for management of liquid HCW

The following actions should be only carried out if no other way of hazardous waste disposal is available or during an emergency and should be considered transitional, interim solution. The use of appropriate PPE is of utmost importance in all situations:

- Body fluids and the contents of suction systems from non-infectious patients from an operating theatre should be discharged via the drain by staff wearing PPE and with all possible further precautions to avoid fluid splashing.
- Stool, vomit, and mucus from highly infectious patients (e.g., cholera patients) should be collected separately and thermally treated before disposal (e.g., by an autoclave reserved for waste treatment). Lime milk (calcium oxide) can be used during emergencies and if no appropriate autoclave or other disinfectant is available.
- Blood can be emptied into a septic or sewerage system if safety measures are followed (e.g., PPE and precautions against spatter). If no other disposal option is available, expired blood bags may be isolated from patients and staff by placing unopened into a protected pit excavated within the grounds of the HCF or at another secure location.
- Solid HCW, especially solid hazardous waste (pharmaceuticals, chemicals), should not be mixed into wastewater.
- Liquid laboratory hazardous waste (colorants, formalin) should be collected separately. Adsorbent (e.g., sawdust) should be used for easier handling. The solid mass should be rendered immobile or encapsulated.
- Chlorine-based disinfectant should be diluted to reach a concentration of <0.5% active chlorine and should be disposed of directly in a soak-away pit. Chlorine-based disinfectant should not be disposed of in a septic tank, because it will harm the biodegradation process.
- Liquid pharmaceuticals in vials (but not cytotoxic materials) can be crushed in a closed bucket, mixed with sawdust, and the solid mass incinerated or encapsulated.
- Glutaraldehyde should be stored after use and can be neutralized using glycine. Subsequently, it can be slowly disposed of via a soak-away pit.

9 Managing Wastewater Generated by Health Care Facilities

As stipulated in the Philippine Clean Water Act of 2004, all HCFs must have its own wastewater treatment plant or must be connected to a municipal or common wastewater treatment facility or an equivalent system for small HCFs (with bed capacity of 25 or less). In some cases, the HCF must provide a pretreatment to the wastewater prior to discharge to the municipal sewer. It is also important that sufficient sanitation facilities are provided in the HCF. The recommended minimum is one toilet per 20 users for inpatient medical areas, and at least four toilets per outpatient location.

9.1 Composition of HCF Wastewater

Health care wastewater is any water that has been adversely affected in quality during the provision of health care services. It is mainly liquid waste, containing some solids produced by humans (staff and patients) or during health care-related processes, including cooking, cleaning, and laundry. Health care wastewater can be divided into the following three categories:

- Blackwater (sewage) is heavily polluted wastewater that contains high concentrations of fecal matter and urine.
- Greywater (sullage) contains more dilute residues from washing, bathing, laboratory processes, laundry, and technical processes such as cooling water or the rinsing of X-ray films.
- Stormwater is technically not a wastewater itself, but represents the rainfall collected on hospital roofs, grounds, yards, and paved surfaces. This may be lost to drains and watercourses and as groundwater recharge, or used for irrigating hospital grounds, toilet flushing and other general washing purposes.

Box 37: Wastewater generation rate in HCFs

Wastewater generation in secondary- and tertiary-level hospitals is mainly measured on an inpatient ratio (liter of generated wastewater per patient treatment day). Typical generation rates are:

- Small—medium-sized hospitals: 300–500 L per inpatient per day
- Large health care settings: 400–700 L per inpatient per day
- University hospitals: 500–>900 L per inpatient per day

In primary health care clinics, the rate of waste generation is often measured as the sum of the number of inpatients and outpatients. Minimum water requirement in the health care setting are (WHO, 2008):

- 40–60 L per inpatient
- 5 L per outpatient
- 100 L per surgical procedure

9.2 Sources and Characteristics of HCF Wastewater

Wastewater from HCFs contains organic particles (feces, hairs, food, vomit, paper fibers, etc.), soluble organic material (urea, proteins, pharmaceuticals, etc.), inorganic particles (sand, grit and metal particles), soluble inorganic material (ammonia, cyanide, hydrogen sulphide, thiosulphates) and other substances. The quality depends on the source of origin.

Table 6: Sources and characteristics of HCF wastewater

HCF Department	Waste Source and Characteristics
Administration and Wards	Urine of patients from some wards (surgery wards, oncology, infectious disease ward, etc.) might contain higher amounts of antibiotics, cytotoxic and X-ray contrast media. These antibiotics and their metabolites are excreted with urine and feces and end up in the wastewater stream, a problem recently recognized worldwide. Hospital wastewaters are a source of bacteria with acquired resistance against antibiotics with a level of at least a factor of 2 to 10 times higher than in domestic wastewater.
Kitchen	Food leftovers, waste from food processing, disinfectants and detergents, starch, grease and oil.
Laundry	It is where greywater is mostly produced. The wastewater often is hot, has a high pH (alkaline) and might contain high amounts of phosphate, surfactants and AOX (adsorbable organically bound halogens) if chlorine-based disinfectants are used.
Operating Room and ICU	Higher contents of disinfectants, detergents and pharmaceuticals. Organic content can be high due to the disposal of body fluids and rinsing liquids (suction containers).
Laboratories	Halogenated and organic solvents, colorants from the histology and hematology (gram staining), cyanides (hematology) and formaldehyde and xylem (pathology) and other reagents, wastewater from autoclaves. Laboratories may also contribute to the presence of blood in wastewater from the emptying of samples into the sinks.
Radiology	Photochemical (developing and fixing solutions) containing wastewater and potentially contaminated rinsing water, fixers and developers. Developing solution can contain formaldehyde, which is a known human carcinogen.
Renal Department/Hemodialysis	Body fluids from machine, disinfectants, dialyzer solutions, wastewater from reverse osmosis process.
Dental Department	Mercury (amalgam) if no amalgam separators are installed; disinfectant, body fluids, wastewater from autoclaves. Mercury is a neurotoxin. It is environmentally persistent and bioaccumulates in the food chain
Central Sterilization Room	Disinfection solution, including aldehyde-based disinfectants. Hot water from the sterilizers and detergents from the CD Machine (Cleaning and Disinfection), wastewater from autoclaves and sterilizing equipment.

Source: Health Care Waste Management Manual, 3rd Edition (DOH, 2011)

9.3 Collection of HCF Wastewater

Segregation, minimization, and safe storage of hazardous materials are just as important for liquid wastes as they are for solid wastes. A wastewater management

must also be implemented by the HCF. The basic principle of effective wastewater management is a strict limit on the discharge of hazardous liquids to sewers.

Wastewater generated in the HCF are collected by sewer pipes, going to the wastewater treatment facility of the HCF or to the municipal sewer to be transported in a treatment facility together with the wastewater from the community. The preferred set-up is to construct separate sewerage systems for wastewater and stormwater (referred to as sanitary sewers and storm sewers). Combined sewerage systems that transport liquid waste discharges and stormwater together to a common treatment facility are no longer recommended. Stormwater or rainwater can be collected separately and used for gardens or other purposes that do not need highly processed water, such as toilet flushing, washing vehicles, or cleaning outdoor paved areas. Furthermore, the separate collection of greywater and blackwater is normally not recommended, because it can cause hydraulic problems (blockages) due to low flow volumes in the collection of the blackwater.

Chemical waste—especially photochemicals, aldehydes (formaldehyde and glutaraldehyde), colorants, and pharmaceuticals—should not be discharged into wastewater but should be collected separately and treated as a chemical HCW.

Radioactive wastewater from radiotherapy (e.g., urine of patients undergoing thyroid treatment) should be collected separately and stored in a secured place until the levels of radioactivity have decreased to background concentrations. After the required storage time, the wastewater can be disposed of into a sewer. A separate toilet facility must be provided to the patients that are given with high doses of radioactive isotopes for therapy.

Larger quantities of blood may be discharged in the sewers if a risk assessment shows that the likely organic loading in the wastewater does not require pre-treatment. Otherwise, blood should be first disinfected, preferably by a thermal method, or disposed of as pathological waste. Blood can also be disposed of directly to a septic tank system if safety measures are followed.

9.4 Treatment of HCF Wastewater

The HCF may provide its own wastewater treatment facility or may connect to a municipal or centralized wastewater treatment facility for the treatment of wastewater.

9.4.1 Connection to a Municipal/Centralized Wastewater Treatment Plant

If the HCF is to be connected in the municipal or in a centralized sewer system, the following are the minimum requirements for discharging to the municipal or centralized sewer system:

- The sewers should be connected to an efficient wastewater treatment plant with primary, secondary, and tertiary treatment;

- A central treatment plant ensures at least a 95% removal of bacteria;
- The sludge resulting from sewage treatment should be subjected to further treatment, such as anaerobic digestion, leaving no more than one helminth egg per liter in the digested sludge; and
- The waste management system of the HCF maintains high standards, ensuring only low quantities of toxic chemicals, pharmaceuticals, radionuclides, cytotoxic drugs, and antibiotics in the discharged sewage.

If the HCF is connected to a municipal sewer system, the HCF may need to provide a pre-treatment to the wastewater prior to discharging to the municipal sewer. The pre-treatment system depends on the quality of the wastewater to be pre-treated and the required quality of the wastewater that can be discharged to the municipal sewer.

Box 38: Pre-treatment of HCF wastewater

Pre-treatment is recommended for wastewater streams from departments such as medical laboratories. This pre-treatment could include acid–base neutralization, filtering to remove sediments, or autoclaving samples from highly infectious patient.

- Non-hazardous chemicals such as syrups, vitamins or eye drops can be discharged to the sewer without pre-treatment.
- A grease trap can be installed to remove grease, oil, and other floating materials from kitchen wastewater. The trap and collected grease should be removed every 2–4 weeks.
- Collected body fluids, small quantities of blood and rinsing liquids from theatres and intensive care can be discharged in the sewer without pre-treatment. Precautions against blood spatter should always be taken (e.g., wearing personal protective equipment [PPE] and following standardized handling procedures), and care should be taken to avoid blood coagulation that could block pipes. Expired blood bags shall not be emptied into a sink because of the risk of infection from blood splatters.
- The 5% sodium hypochlorite (NaOCl – bleach) is not effective for disinfecting liquids with a high organic content such as blood and stools. Sodium hypochlorite should never be mixed with detergents or used for disinfecting ammonia-containing liquids, because it might form toxic gases.
- Chlorine-based disinfectants (such as sodium hypochlorite) shall not be disposed of in a septic tank as it will harm the bacteria used for the biological treatment process.
- Lime milk (calcium oxide) can be used to destroy microorganisms in liquid wastes with high organic content requiring disinfection (e.g., stool or vomit during a cholera outbreak). In these cases, feces, and vomit should be mixed with the lime milk in a ratio of 1:2, with a minimum contact time of six hours. Urine can be mixed 1:1, with a minimum contact time of two hours (Robert Koch Institute, 2003).
- Wastewater from the dental department should be pre-treated by installing an amalgam separator in sinks, particularly those next to patient treatment chairs. Mercury waste must be safely stored.

9.4.2 On-site Wastewater Treatment Plant (WWTP)

Larger HCFs, particularly those that are not connected to any municipal treatment plant, should operate their own wastewater-treatment plant. This could include physical, chemical, and biological processes to remove contaminants from the raw sewage. The advantages and disadvantages of different types of WWTP

technology and the factors to consider for establishment of on-site WWTP are listed in **ANNEX B 7** and **ANNEX B 8**, respectively.

Typically, wastewater treatment involves three stages (refer to **ANNEX A 8** for the process flow diagram). The first stage is the removal of solids that are separated by sedimentation (primary treatment). Second, dissolved biological matter is progressively converted into a solid mass using indigenous waterborne bacteria. Some inorganic components will be eliminated by sorption to sludge particles, which are then separated from the liquid phase of the wastewater by sedimentation (secondary treatment). During the third stage (at the end of the treatment process), after the solid and liquid materials are separated, the treated water may be further treated to remove suspended solids, phosphates, or other chemical contaminants, or may be disinfected (tertiary treatment).

9.4.2.1 Disposal of treated effluent

The treated effluent of the on-site wastewater treatment plant must comply to the general effluent standards of DENR-EMB (DAO 2016-08) prior to discharge. The quality of the treated effluent required depends on the classification of the discharging water body. The significant effluent quality parameters for the HCFs according to DAO 2016-08 are shown in **Table 7**.

Table 7: Significant effluent parameters for HCFs

PSIC Code	Industry Category	Significant Parameters
86, 87	Hospitals, clinics, nursing homes and other health and residential care activities	<ul style="list-style-type: none"> • Color • Temperature • pH • Biochemical Oxygen Demand (BOD) • Total Suspended Solids (TSS) • Fecal Coliform • Ammonia • Nitrate • Phosphate • Oil and Grease • Surfactants
86900	Other human health activities- medical laboratories inside and outside of medical facilities	All significant parameters depending on the nature of their activity.

Source: DAO 2016-08

9.4.2.2 Disposal of sludge

The treatment process of the wastewater will generate sludge or biosolids that contains high concentrations of helminths and other pathogens and should be treated before disposal. The most common treatment options include anaerobic digestion, aerobic digestion, and composting. Composting or sludge de-watering and mineralization beds are most commonly used for on-site treatment in hospitals.

For composting, sludge is mixed with a carbon source such as sawdust, straw, or wood chips. In the presence of oxygen, bacteria digest the sludge and the carbon source, and create heat that will pasteurize the sludge. In dewatering and mineralization beds, sludge is applied on a horizontal system – flow reed bed (refer to **ANNEX E 10**). One part of the water is absorbed by the reeds, which then transpire moisture into the air; the other part is returned to the wastewater treatment plant through a drainage layer in the bottom of the reed bed. The de-watered sludge is incorporated into the microbiologically active top layers of the root zone of the reeds, where it is mineralized and turned into soil.

9.4.2.3 Re-use of wastewater effluent and sludge

The reuse of wastewater and sludge from hospitals with standard wastewater-treatment plants is generally not recommended and should only be done if knowledgeable staff and appropriate testing facilities are available. Wastewater treatment plants of HCF often face operational problems, due to concerns about chemicals and pharmaceuticals in wastewater and the potential hygiene risks. The use of treated health care wastewater should only be carried out if resources to meet environmental and safety standards can be assured and the relevant national or WHO guidelines on wastewaters and sludge can be followed. If the treated effluent will be reused for irrigation, the standards in DA Administrative Order 2007-26 must be complied.

If sludge is reused for agricultural purposes, it should be tested to confirm that it does not contain more than one helminth egg per gram of total solids and contains no more than 1000 fecal coliforms per gram of total solids (WHO, 2006). The sludge should be applied to fields in trenches and then immediately covered with soil.

9.4.3 Emerging Technologies

Membrane Biological Reactor (MBR) is a combination of activated sludge treatment with a membrane liquid–solid separation process. The membrane component uses low-pressure microfiltration or ultrafiltration membranes and eliminates the need for clarification and tertiary filtration. The membranes are typically immersed in the aeration tank (however, some applications use a separate membrane tank).

Anaerobic pre-treatment with reed beds is a process in which microorganisms convert organic matter into biogas in the absence of oxygen. An anaerobic system can be used for pre-treatment prior to discharging to a municipal wastewater treatment plant or before polishing in an aerobic process. Reed bed system for wastewater treatment has been proven to be effective and sustainable alternative for conventional wastewater treatment technologies. Use of macrophytes to treat wastewater is also categorized in this method.

9.4.4 Operation Monitoring and Maintenance of WWTP

The following elements must be in place for the efficient and effective operation and maintenance of the WWTP system:

- Awareness among the management and senior staff on wastewater problems;
- Physical Asset Management (PAM) and Preventive Maintenance Program (PMP);
- Basic tools to carry out regular maintenance;
- PPE and other safety equipment measures;
- Trained operators and workers; and
- Budget for operational costs and regular maintenance.

The management shall designate wastewater treatment operator who will be responsible for the operation and maintenance of the WWTP. A maintenance plan which includes corrective as well as preventive maintenance shall be set up for the collection, pre-treatment, and treatment of wastewater.

For monitoring, regular testing of the influent as well as the effluent shall be monitored to test the efficiency of the treatment plant. Parameters required by DAO 2016-08 Water Quality Guidelines and General Effluent Standards of 2016 will be tested based on the prescribed frequency.

9.4.5 Basic Wastewater Treatment System for Rural HCF

For HCFs, especially primary care facilities and HCFs located in the rural areas, that do not have an on-site wastewater treatment plant or a sewerage system in their area may opt to provide basic wastewater treatment system. This system consists of a primary and secondary treatment stage, which is considered as the minimum treatment for primary- and secondary- level rural hospitals.

Note that sludge and sewage from HCF generated by a basic wastewater management system should never be used for agricultural or aquaculture purposes. Effluents from the basic treatment should not be discharged into water bodies that are used nearby to irrigate fruit or vegetable crops or to produce drinking-water or for recreational purposes.

Basic systems can reduce the risk of waterborne diseases drastically if appropriately planned and implemented; more advanced systems reduce the risk further. Pharmaceuticals and other hazardous liquid wastes in wastewater may form a serious future problem and must be carefully observed and minimized. This includes reducing to an absolute minimum the presence of antibiotics and pharmaceutical residues in wastewater.

There are three basic wastewater management systems that can be used by the HCFs: (1) septic tank system; (2) centralized basic system; and (3) lagoon system.

The effluent from septic tank and centralized basic systems can be further treated but if not possible, a controlled discharge to soakaway pits or leachfields should be carried out. However, soakaway pits and leachfields present a threat of contamination to nearby wells. Both should be kept as far as practicable from shallow water wells and, where possible, they should be installed downstream of water abstraction sources. The distance between the bottom of the infiltration system and the groundwater table should be at least 1.5 meters (more in coarse sands, gravels, and fissured geological formations), and the system should be at least 30 meters from any groundwater source (Harvey, 2002).

9.4.5.1 Septic tank system

The minimum treatment method for wastewater is the septic tank, a watertight receptacle for the separation of solid and liquid components of wastewater and for the digestion of organic matter in an anaerobic environment. A septic tank also takes on the functions of storing solids and allowing clarified liquid to outflow for further treatment or discharge.

A septic tank normally consists of two or more chambers and can be divided into the following zones: (1) horizontal: inflow, settlement and clarifying zone; and (2) vertical: scum, detention, and sludge zone. The capacity of the septic tank should be equivalent to a total of two days' wastewater flow. If a two-chamber system is used, the first chamber should be two-thirds of the total capacity. The effective settling and floating of solids are directly dependent upon the retention time within the tank, which should be not less than 24 hours. Anaerobic bacteria partly break down this solid matter.

Note that excessive build-up of sludge and scum reduces the capacity of the detention zone, resulting in discharge of suspended solids to the effluent disposal system. Specific guidelines on the design, construction/installation, operation, and maintenance of septic tank systems are provided in the DOH AO No. 2019-0047 (see **ANNEX F 1** for link to the document). The operation and maintenance criteria are presented in **Box 38**.

Box 39: Septic tank systems operation and maintenance criteria

The national standard for septic tank systems operation and maintenance consists of the ff. criteria:

- Septic tank must be desludged every four (4) years to maintain its designed treatment efficiency.
- Keep a record of pumping, inspections, maintenance, and repairs.
- Inspect the tank for cracks, and check that baffles or tees are in place. Check for ponding of water near the treatment and disposal system.
- Refrain from using septic starters, additives, or feeders (i.e., enzymes).

- Practice water conservation to prevent overloading the septic tank system. Check for defective toilet tank valves, repair leaky fixtures, and install appliances and fixtures that use less water and avoid wasteful practices.
- Divert excess rainwater runoff away from the septic tank and leaching field system.
- Keep trees and deep-rooted plants and shrubs away from the immediate area that may intrude or clog the system.
- Do not park or drive heavy vehicles or equipment over the septic system or any of its components.

Reference: DOH AO No. 2019-0047 "National Standard on the Design, Construction, Operation and Maintenance of Septic Tank Systems"

9.4.5.2 Centralized basic system

Basic centralized systems consist of primary treatment (sand catchment and screen to remove large particles) and an anaerobic secondary treatment system. This is recommended for HCF to minimize maintenance, allow more advanced treatment, and improve the monitoring of the wastewater system. Typical secondary treatment systems include: (1) baffled flow reactors; (2) anaerobic filters; (3) Imhoff tank; and (4) upflow anaerobic sludge blanket reactor. Most of the systems allow for the harvesting of methane biogas if facilities are available. The effluents can be further treated. If this is not possible, a controlled discharge to soakaway pits or leachfields should be carried out.

A. Soakaway Pits

A soakaway pit should have one or more tanks, with the total volume equal to the wastewater-treatment plant. Effluents from the treatment plant are collected and allowed to infiltrate into the ground. The pit may be filled with stones, broken bricks or similar material or may be lined with open-jointed masonry. The top 0.5 meter of the pit should be lined solidly, to provide firm support for a reinforced concrete cover. Planting trees adjacent to or over a soakaway can improve liquid removal through transpiration and increased soil permeability.

B. Leachfields

When larger amounts of wastewater need to be infiltrated (e.g., district hospitals), a leachfield is often a better solution. Leachfields consist of gravel-filled underground trenches, called leachlines, which allow the liquid effluent from the wastewater treatment to permeate into the ground. A leachfield may be characterized by: open-jointed (stoneware) or perforated (polyvinyl chloride) pipes carry the liquid effluent into the leachfield; trenches that are usually 0.3–0.5 meter wide and 0.6–1.0 meter deep (from the top of the pipes) and laid with a 0.2–0.3% gradient of gravel (20–50mm diameter), covered by a 0.3–0.5 meter layer of soil.

9.4.5.3 Lagoon system

In an individual HCF that cannot afford sophisticated sewage-treatment plants, and where infiltration of the wastewater is not possible, a lagoon system is a basic

solution for treating wastewater, if enough land is available. There are two lagoon systems that can be considered; aerated lagoon and facultative lagoon.

A. Aerated Lagoons

Oxygen is supplied by mechanical surface aeration thus requires comparatively high operational costs due to electricity.

B. Facultative Lagoons

Oxygen is supplied primarily by algae. Facultative means the presence of an anaerobic bottom region below an aerobic top layer. Facultative lagoons consist of a shallow basin in which settleable solids carried by the wastewater fall to the bottom and form a sludge layer that decomposes anaerobically. Facultative lagoons can have the disadvantages of potentially generating pungent odors, variable effluent quality, and a need for a large land surface area.

Box 40: Guide to basic wastewater system

Basic systems can reduce the risk of waterborne diseases drastically if appropriately planned and implemented; more advanced systems reduce the risk further. Pharmaceuticals and other hazardous liquid wastes in wastewater may form a serious future problem and must be carefully observed and minimized. This includes reducing to an absolute minimum the presence of antibiotics and pharmaceutical residues in wastewater. A good, well-maintained sewerage system is as important as an efficient wastewater-treatment plant.

- *Enforce liquid hazardous waste management; segregate and pre-treat hazardous waste.*
- *Set up a maintenance system for the sewers and the septic tanks, provide maintenance equipment and clean septic tanks regularly.*
- *Set up a budget line to cover wastewater-treatment costs.*
- *Ensure that chemical disinfection is only used when the suspended organic matter in wastewater is >10 mg/l.*
- *Replace any broken or non-watertight septic tanks and install sewer pipes with watertight joints.*
- *Install grease traps for the kitchen wastewater and clean regularly.*
- *Regularly inspect the sewerage system and repair whenever necessary.*
- *Introduce tertiary treatment systems such as sand filtration or a subsurface horizontal gravel filter overplanted with vegetation to increase transpiration.*
- *Disinfect the wastewater by UV or change to chlorine dioxide or ozone (a combination of UV and ozone is most effective).*
- *Neutralize wastewater from laboratories before discharge into the sewerage system.*
- *Set up an "antibiotic committee" to minimize the usage of antibiotics within the HCF.*

10 Administrative Requirements

Appropriate HCWM practices depend largely on the administration and organization and require adequate legislative and financial support, as well as the active participation by trained and informed staff.

10.1 Oversight and Management at the National and Local Levels

In the Joint DENR-DOH Administrative Order No. 02, Series of 2005, specific duties and responsibilities have been indicated for the Department of Environment and Natural Resources (DENR) through the Environmental Management Bureau (EMB) and its regional offices, the National Solid Waste Management Commission (NSWMC) and the department of Health (DOH) through its Center for Health Development (CHD), Bureau of Health Devices and Technology (BHDT), Environmental and Occupational Health Office (EOHO) of the National Center for Disease Prevention and Control (NCDPC), the National Center for Health Facility Development (NCHFD), and the National Reference Laboratory (NRL) – East Avenue Medical Center, Quezon City.

Table 8: Responsibilities of implementing and cooperating agencies for HCWM

Agency	Responsibilities
DENR through the EMB and its regional offices	<ul style="list-style-type: none"> Formulate and implement pertinent rules and regulations on the management of HCW in the Philippines, particularly concerning the issuance of necessary permits and clearances for the Transport, Treatment, Storage and Disposal of such wastes, as governed by PD 1586, RA 6969, RA 8749, RA 9275, and RA 9003; Formulate policies, standards, and guidelines on the transport, treatment, storage, and disposal of HCW; Oversee compliance by generators, transporters, TSD facility operators, and/or final disposal facility operators with the proper transport, treatment, storage, and disposal of HCW; Conduct regular sampling and monitoring of wastewater in HCFs and TSD facilities to determine compliance with the provisions of RA 9275; Require TSD facility operators and on-site treaters to present to the DENR copies of the results of microbiological tests on the HCW treated using autoclave, microwave, hydroclave, and other disinfection facilities prior to the renewal of their Permits under RA 6969; Provide technical assistance and support to the advocacy programs on HCWM; and Notify the DOH on cases of non-compliance or notice of violation issued to HCF, institutions and establishments licensed by the DOH.
DOH	<ul style="list-style-type: none"> Include HCWM criteria in the licensing and accreditation requirements for HCFs; Formulate policies, plans, standards, guidelines, systems, and procedures on the management of HCW; Develop training programs and corresponding modules on HCWM; Provide technical and resource mobilization to ensure an effective and efficient implementation of HCWM program; Require all HCW TSD facility operators and HCW generators with on-site waste treatment facilities to use DOH-BHDT registered equipment or

Agency	Responsibilities
	<p>devices used for the treatment of HCW;</p> <ul style="list-style-type: none"> • Conduct regular performance evaluation of equipment/devices used for the treatment of HCW by the DOH-BHDT; • Monitor the microbiological test of treated wastes to ensure compliance with DOH standards; • Evaluate the HCF's compliance with proper HCWM program and provide incentive program for compliant hospital and for best practices; • Issue Department Circulars to ensure that all environmental requirements are complied with; and • Notify the DENR on actions taken on cases of non-compliance or notice of violation issued to HCF, institutions and business establishments.
DOH Centers for Health Development	<ul style="list-style-type: none"> • Advocate HCWM practices to the Local Chief Executives, key leaders, and other stakeholders; • Monitor HCWM implementation and compliance of DOH-licensed HCF and submit reports to DOH; and • Provide technical assistance on HCWM through: <ul style="list-style-type: none"> ○ Training ○ Issuance of advisory on the preparation of HCWM Plan as a requirement for licensing or renewal thereof ○ Dissemination of policies, guidelines, and information ○ Monitoring and validation of the implementation of HCWM ○ Development, reproduction, and dissemination of HCWM IEC materials ○ Participation in any public hearing related to HCWM
Philippine Health Insurance Corporation (PHIC) and other accrediting bodies/agencies	<ul style="list-style-type: none"> • Incorporate the following in the core indicator requirements for HCFs to qualify as Center of Safety, Center of Quality and/or Center for Excellence: <ul style="list-style-type: none"> ○ HCWM Plan being implemented and monitored within the HCF ○ Functional organized and established HCWM Committee ○ Proper waste management segregation and compliance to color-coding ○ On-site or off-site treatment disposal ○ Updated discharge permit ○ Waste generator ID ○ Adequate signage in place for HCW deposition and other established criteria for HCFs to meet the standards for safety, quality, and excellence
Department of Interior and Local Government (DILG) through the different Local Government Units (LGUs)	<ul style="list-style-type: none"> • Monitor the compliance of HCFs under its jurisdiction on the proper waste management, segregation, and disposal; • Provide assistance in the provision of an appropriate landfill, collection of waste, and installation of the WWTP within the municipality; and • Ensure HCF's compliance with mandatory requirements for the transport, treatment storage and disposal of HCW as governed by PD 1586, RA 6969, RA 8749, RA 9275, and RA 9003.

Source: Health Care Waste Management Manual, 3rd Edition (DOH, 2011)

10.2 Administrative Requirements at the Facility Level

The HCF has to comply with certain administrative requirements for a functional HCWM. The requirements include the overall aspect of HCWM in the facility including the organized committee and plan of operations.

The following are the administrative requirements for the HCF:

- 1) Organization of a HCWM Committee
 - a) Identification of functions, roles, and responsibilities

- b) Designation, identification, and appointment of core members
- 2) Formulation of a comprehensive HCWM Plan
 - a) Assessment of waste generation and waste disposal
 - b) Review of existing HCWM policies and procedures being implemented
 - c) Formulation and drafting of HCWM Plan
- 3) Adoption of different approaches to waste management as tools in the development of HCWM Plan:
 - a) Life Cycle Analysis (LCA) is a “cradle to grave” approach to estimate the cumulative environmental impacts associated with the life cycle (manufacture, use and maintenance to its final disposal) of a product, process, or service.
 - b) Environmental Management System (ISO 14001) is a continuous process of improvement which involves environmental planning, implementation, checking and management review on the programs being implemented within the HCF in compliance with existing environmental and HCWM laws and policies.
- 4) Monitoring and Evaluation of the HCWM Plan – This is to validate the effectiveness and the efficiency of the HCWM Plan. This includes using the designated tools such as Self-Monitoring Sheet (for links, please refer to **ANNEX D 4** of this Manual). The six major parameters that will be used to determine the extent of the plan implementation are the following:
 - a) Waste Minimization Practices
 - b) Waste Segregation
 - c) Waste On-Site Collection, Transport and Disposal
 - d) Waste Treatment On-Site (if applicable)
 - e) Wastewater Management
 - f) Administrative Control
- 5) Communication and Training – All HCFs, the DOH and the EMB-DENR have the responsibility and a “duty of care” for the environment and public health, particularly in the institutionalization of awareness among HCW and the general public. (please refer to **Chapter 11.6** for detailed discussion)
 - a) Methods of communication and training used
 - b) Training of health care workers
 - c) Training package for each target group

10.3 Budgetary Requirements to Implement the HCWM Program

The benefits of HCWM are in terms of infection control, protection of HCF workers, and the protection of the environment and the accreditation of the HCF with the national social health insurance scheme or PhilHealth. To realize these benefits and be compliant with the existing laws and policies, the HCF needs to identify the most cost-effective option that fits its needs and financial capacities. Consequently, each HCF should be financially responsible for the safe management of any waste it generates. This is in accordance with the widely accepted “polluter pays” principle and the obligation of the duty of care.

10.3.1 Investment and Operations Cost

The costs of separate collection, packaging and on-site handling are internal to the establishment; while costs of off-site transport, treatment and final disposal are external and paid to the contractors who provide the service. The costs that will be incurred by the HCF in managing HCW will include:

10.3.1.1 Waste segregation and on-site handling

Proper segregation and on-site handling of wastes includes the cost for the following materials, goods, and services:

- Waste bins, color-coded plastic liners that shall be placed in appropriate locations in the hospital, transport trolleys and collection bins;
- Proper labels for the waste bins, tags for the plastic liners and signage/posters;
- Training of personnel to place wastes in the appropriate containers and to handle them in a safe manner;
- IEC materials;
- Storage spaces for HCW within the HCF, spill kits and measure to secure and protect the wastes when needed;
- PPE needed to safely and properly handle wastes;
- Occupational health and safety measures such as immunization;
- Sealer for plastic liners and packing the wastes for transport if the treatment facility is located at a distance from the HCF;
- Transportation borne by the HCF; and
- Operating and maintenance costs including salaries and wages.

Segregation of wastes effectively reduces the amount of wastes needed for transport (if located off-site), treatment and disposal at the treatment facility. Investments in training and equipment may not be offset by lower costs. However,

total costs to the environment will diminish because the inclusion of materials that may release harmful substances to the environment during treatment processes is lessened.

10.3.12 Waste treatment

Establishing and operating an on-site waste treatment include the investment and operating costs listed below:

- Non-burn waste treatment technology and its accessories and related processes;
- Microbiological testing equipment and supplies;
- Installation and facility costs: installation labor, facility modifications – cement pad/s, curb cuts, sewers, electricity, space, security, etc.;
- Costs of pollution control equipment if required to control emissions and effluents from the facility (e.g., wastewater treatment plant);
- Construction of temporary storage and hauling areas for treated wastes;
- Direct labor costs: number of HCF workers needed to operate the treatment and disposal equipment;
- “Down time” costs: including repair (parts and labor) and alternative treatment;
- Operating costs if the facility uses special chemicals and catalysts;
- Utility costs;
- Permitting and compliance fees: water and air monitoring fees, Environmental Compliance Certificate (ECC), Discharge Permit (DP), Permit to Operate (PTO) Pollution Source Equipment (e.g., generator sets), and registration with the DENR as waste generator, treater and/or transporter;
- Fines: depending on permit requirements, national and local regulations; violations of permits or emissions which may result to the payment of fines;
- All transportation, processing, and tipping fees;
- Supply costs – personal protective equipment, spill supplies, special bags (e.g., some autoclaving systems require specific bags), collection containers (boxes or reusable containers);
- Community approval cost if a public hearing is required; and
- Sterilization equipment.

In cases where the HCF enters into a contract with a DENR-accredited TSD, the costs that will be incurred by the HCF will be charges of the waste treater and the

associated transportation costs. Investment in on-site treatment facilities may be costly but allows the HCF to control how the waste is treated as well as the costs associated with treatment. Off-site treatment facilities, when available, may be more costly in the long run but it allows the HCF to concentrate on its basic occupational function and not on operations it is not built to do, which is the treatment of waste.

10.3.1.3 Disposal

Disposal to a sanitary landfill is considerably more costly than disposal in open dumpsites; sanitary landfills may charge a higher fee for waste coming from HCFs. In evaluating treatment options, costs with relation to final disposal shall be considered since treatment systems can almost eliminate wastes altogether (pyrolysis) but some even increase the weight of wastes (steam systems without dryers). Care shall also be taken to render the wastes unrecognizable.

The following are some costs that should be considered when using an on-site facility for the disposal of treated waste:

- Construction of temporary storage and hauling areas for treated waste;
- Costs related to wastes not handled by the hauler;
- Cost of encapsulation, inertization, septic vault;
- Labor costs for hauling, labelling, waste documentation, security, and maintenance of temporary storage areas;
- Hauling costs;
- Transport containers; and
- Landfill tipping fees.

10.3.2 Costing Tools

The WHO prepared two (2) costing tools to help calculate the true cost of setting up an HCWM system: the Costing Analysis Tool (CAT), which estimates the costs of HCWM at the national and HCF levels; and the Expanded Costing Analysis Tool (ECAT), which is a modified version of the CAT and estimates costs at the HCF, central treatment facility, or cluster and national levels.

Both costing tools require some basic data, such as the amounts of waste generated and the number of facilities, and then apply assumptions to compute average annualized capital and operating costs for HCFs of different bed sizes, as well as costs on the national level. Users can input specific values (such as the unit price of a wheeled cart or the wage rate) or use the default values in the tool. CAT deals only with on-site treatment. ECAT expands on CAT by differentiating between low-, middle-, and high-income countries; providing more size categories for HCFs (based on number of beds); presenting more treatment options (autoclaves and autoclave shredders, incinerators, microwave treatment, and hybrid steam

treatment systems); and allowing the user to define a mix of centralized and decentralized treatment.

Links to these tools are provided in **ANNEX F 1** of this Manual.

10.3.3 Measures to Reduce Costs

In the long run, cost reductions can be achieved by implementing the following measures at the different stages in the management of wastes:

A. Comprehensive Planning

- Development and implementation of a comprehensive HCWM Plan which includes the recommendations below on on-site management;
- Designing all elements of the system to be of adequate capacity in order to obviate the need for subsequent costly modifications;
- Anticipating future trends in waste production and the likelihood of legislation becoming more stringent;
- Planning collection and transport in such a way that all operations are safe and cost-efficient;
- Possible cooperative use of regional waste treatment facilities, including private sector facilities when appropriate; and
- Establishment of wastewater disposal plan

B. On-site Management (Source Reduction, Recycling, and Re-Use)

- Comprehensive management of chemicals and pharmaceuticals stores, which includes centralized purchase and use of chemicals and pharmaceuticals; and the centralized monitoring of chemical flows within the HCF;
- Improved waste identification to simplify segregation, treatment, and recycling;
- Reduction of the amount of material used to accomplish tasks (e.g., use of email instead of paper and the use of smaller amounts of disinfectant to clean rooms);
- Reduction of toxicity of the materials used in order to reduce the disposal costs and the hazards to the HCF workers. Purchase of materials that may be reused and recycled such as in the case of disposable medical care items and reusable salad plates for the hospital cafeteria;
- Practice just in time delivery in order to minimize on wastes incurred due to the expiry of items like drugs and chemicals; and
- Adequate segregation of waste to avoid costly or inadequate treatment of waste that does not require it.

C. Adequate Treatment and Disposal Method

- Selection of a treatment and disposal option that is appropriate for waste type and local circumstances;
- Use of treatment equipment appropriate type and capacity; and
- Possible cooperation between local HCFs.

D. Measures at Worker Level

- Establishment of training programs for HCF workers to improve the quality and quantity of work; and
- Protection of HCF workers against occupational risks.

E. Documentation

- Documentation of waste management and assessment of the true costs makes it easier to identify priorities for cost reduction and to monitor progress in the achievement of objectives.

10.4 Options for Financing

HCWM may be financed through in-house funds of the HCF, revenues from recyclable waste, loans from credit facilities and through sub-contracting, partnerships or joint venture with other institutions providing TSD services (sharing WWTP, waste treatment, mercury storage).

Government-owned or private HCF may use internal revenues to pay for the cost of the HCWM system. The costs of managing HCW shall be covered by a separate budget line item in the HCF budget. In case in-house funds are not available, HCF and TSD facilities can avail of credit financing for the investment and operation costs of HCW treatment, wastewater treatment, and air pollution control devices from loan facilities, such as the Environmental Infrastructure Support Credit Program (EISCP) of the Development Bank of the Philippines (DBP).

Privatization is a method of financing various types of public works, including HCWM. Under such an arrangement a private entity finances, designs, builds, owns, and operates the treatment facilities and sells its collection and disposal services to government and private HCF. Privatization is an option that may be considered under the following conditions:

- Inability of hospitals to raise the needed capital;
- Expected greater efficiency in the private sector because of fewer constraints than in the public sector (e.g., greater flexibility in purchasing and personnel policies, allowing for more rapid adaptation to changing needs); and
- Transfer of responsibility for proper operation and maintenance to an

organization with more resources for minimizing risk.

However, a perceived disadvantage of privatization is the potential loss of overall control of waste management operations by the HCF. The risk of a service failure is minimized where a facility has a well-functioning contract management team in place and has negotiated a contract with penalties for poor service.

In contracting with the private sector, the agreement between the private operator and the HCF shall include agreements on the following issues:

- Minimum risk level of service, especially with regards to reliability, safety, public health risk and future expansions;
- Future increases in cost resulting from factors that cannot be fully assessed at the outset;
- Environmental concerns;
- Future transfer of ownership of the facilities; and
- Regular inspection and regulatory control.

11 Health and Safety Practices

HCWM policies, plans, and programs shall include provision for the health and safety of HCF workers. Educating the HCF workers on the risks associated with HCW shall be part of this policy. Established policies and procedures ensuring the health and safety of HCF workers from generation, segregation, storage, to collection, transport, treatment, and disposal of HCW shall be consistently implemented and complied by all concerned. The purpose of this chapter is to explain the hazards and infection risks they may encounter, and the prevention and control of exposure to them. HCWM policies or plans should include arrangement for the continuous monitoring of workers' health and safety.

11.1 Principles

Sensible occupational health and safety measures include the following:

- Develop a standardized set of management rules and operating procedures for HCW, when respected by personnel and monitored by the hospital management, can dramatically reduce the risk of accidents. Hospital staff should be taught and kept informed about the HCWM system and procedures in place.
- Inform and train waste workers so that they perform their duties properly and safely. Training in health and safety is intended to ensure that workers know of and understand the potential risks associated with HCW, and the rules and procedures they are required to respect for its safe management.
- Involve waste workers in hazards identification and recommendations for prevention and control. Workers at risk from infection and injury include health care providers, cleaners/maintenance staff, treatment equipment operators, and all personnel involved in waste handling and disposal within and outside HCFs.
- Provide equipment and clothing for personal protection. They should be informed on the importance of consistent use of personal protective equipment (PPE) and should be aware of where to obtain post-exposure follow-up in case of a needle-stick injury or other blood exposure.
- Establish an occupational health program that includes information, training, and medical measures when necessary, such as immunization, post-exposure prophylactic treatment and regular medical surveillance. Health care personnel should be trained for emergency response if injured by a waste item, and the necessary equipment should always be readily available. Written procedures for the different types of emergencies

should be drawn up.

To limit the risks, the hospital management must set up management rules and operating procedures for HCW and establish standardized emergency procedures. It is the responsibility of everybody involved in handling waste to know the emergency procedures and to act accordingly.

11.2 Occupational Health Risks

11.2.1 Cytotoxic Safety

In hospitals that use cytotoxic products, specific guidelines on their safe handling should be established for the protection of personnel. These guidelines should include rules on the following waste handling procedures:

- Separate collection of waste in leak-proof bags or containers and labelling for identification;
- Return of outdated drugs to suppliers;
- Safe separate storage of genotoxic waste away from other HCW;
- Arrangements for the disposal of contaminated material, the decontamination of reusable equipment and the clean-up of spillages; and
- Arrangements for the treatment of infectious waste contaminated with cytotoxic products, including excreta from patients, disposable linen, and absorbent material for incontinent patients.

The following measures are important to minimize exposure:

- Written procedures that specify safe working methods for each process;
- Data sheets, based on the suppliers' specifications, to provide information on potential hazards and their minimization;
- Established procedure for emergency response in case of spillage or other occupational accident (such as needle prick injury—refer to **ANNEX C 7**); and
- Appropriate education and training for all personnel involved in handling of cytotoxic drugs.

Hospital staff should ensure that the families of patients undergoing chemotherapy at home are aware of the risks and know how they can be minimized or avoided. The senior pharmacist at the HCF should be made responsible for ensuring the safe use of cytotoxic drugs. Large oncological hospitals may appoint a full-time genotoxic safety officer, who should also supervise the safe management of cytotoxic waste.

11.2.2 Other Health Hazards

Actual cases of non-sharps waste being demonstrated to cause an infection in health care personnel and waste workers are rarely documented. HCW handlers are at greatest risk from infectious hazards, which include chemical exposures such as chemotherapeutic drugs, disinfectants, and sterilants; physical hazards such as ionizing radiation; and ergonomic hazards. The risk of acquiring a secondary infection following needle-stick injury from a contaminated sharp depends on the amount of the contamination and nature of the infection from the source patient. The risk of infection with hepatitis B is more than 10 times greater than for hepatitis C, and up to 100 times greater than for HIV.

Table 9: Hazards to health care workers

Hazards	Health Effects	Control Measures
Sharps injuries and resulting exposure to bloodborne pathogens	<ul style="list-style-type: none"> Infections with hepatitis B or C, HIV, malaria or other bloodborne infections (Prüss-Ustün, Rapiti & Hutin, 2005) 	<ul style="list-style-type: none"> Immunization against Hepatitis B virus (WHO, 2009) Appropriate disposal of sharps at site of use into a puncture-resistant container without recapping (Hutin et al., 2003; WHO, 2010); Use of engineered needles that automatically retract, blunt re-sheath, or disable the sharp (CDC, 1997; Lamontagne et al., 2007)
Other biological hazards	<ul style="list-style-type: none"> SARS (WHO, 2007a, 2009b) Tuberculosis, Influenza 	<ul style="list-style-type: none"> Exhaust ventilation (natural or mechanical) (WHO, 2009c, 2009d)
Chemicals Chlorine disinfectants (sodium hypochlorite)	<ul style="list-style-type: none"> Skin and respiratory sensitization (International Programme on Chemical Safety, 1999; Zock et al., 2007) Eye and skin irritation, weakness, exhaustion, drowsiness, dizziness, numbness and nausea 	<ul style="list-style-type: none"> Substitute soap and water for cleaning chemicals Avoid soaking of sharps in chlorine when they will receive autoclaving or incineration before disposal Dilute chemicals appropriately according to manufacturer for less toxic exposure (Zock, Vizcaya & Le Moulal, 2010)
High-level disinfectant glutaraldehyde	<ul style="list-style-type: none"> Irritation of the eyes, nose and throat Skin sensitization Occupational asthma where the symptoms in affected individuals include chest tightness and difficulty in breathing (Mirabelli et al., 2007) 	<ul style="list-style-type: none"> Substitute steam sterilization except for pressure sensitive instruments (Harrison, 2000; Pechter et al., 2005) Ensure appropriate dilution and use in closed, ventilated system
Sterilants: ethylene oxide (International Programme in Chemical Safety, 2003)	<ul style="list-style-type: none"> Eye and skin irritation, difficulty breathing, nausea, vomiting, and neurological problems such as headache and dizziness. Reproductive hazard, linked to nerve and genetic damage, spontaneous abortion and muscle weakness Carcinogen (IARC, 1999) 	<ul style="list-style-type: none"> Substitute steam sterilization for ethylene oxide except for pressure-sensitive instruments (EPA, 2002) Use only in a closed and ventilated system
Heavy lifting	<ul style="list-style-type: none"> Back injuries and 	<ul style="list-style-type: none"> Reduce mass of objects or number of

Handling heavy loads over long periods	musculoskeletal disorders (Schneider & Irastorza, 2010) Degenerative diseases of the lumbar spine	loads carried per day (Nelson, 2003) • Use waste carts with wheels, automated waste transfer from cart to truck and treatment Use lifts and pulleys to assist in transferring loads
Ionizing radiation	• Irreversible damage of cells, anemia, leukemia, lung cancer from inhalation (Niu, Deboodt & Zeeb, 2010)	• Safe waste management, in full compliance with all relevant regulations. must be considered and planned for at the early stages of any projects involving radioactive materials It should be established from the outset that the waste can be properly handled, treated and ultimately disposed of See International Atomic Energy Agency for national regulatory standards and safety guidance (IAEA, 1995)
Source: Safe Management of Wastes from Health-Care Activities, 2nd Edition (WHO, 2014)		

11.3 Exposure Prevention and Control

A proper and safe segregation system for hazardous waste is the key to occupational safety and environmental sound handling. Implementing a proper segregation system must be accompanied by safe and standardized handling procedures.

11.3.1 Hierarchy of Controls for Bloodborne Pathogens

Methods to control occupational hazards have traditionally been discussed in terms of hierarchy and presented in order of priority for their effectiveness in preventing exposure to the hazard or preventing injury resulting from exposure to the hazard. Controlling exposures to occupational hazards is the fundamental method of protecting workers. Hierarchy of controls has been used as a means of determining feasible and effective controls. One representation of this hierarchy can be summarized as follows.

11.3.1.1 Elimination and Substitution

Complete removal of a hazard from the work area. Elimination is the method preferred in controlling hazards and should be selected whenever possible. While most effective at reducing hazards, also tend to be the most difficult to implement in an existing process. If the process is still at the design or development stage, elimination of hazard and substitution of control may be inexpensive and simple to implement.

On existing process, major changes in equipment and procedures may be required to eliminate hazards or substitute control. Examples include removing sharps and needles and eliminating all unnecessary injections. Jet injectors may substitute for syringes and needles. All unnecessary sharps, such as towel clips, should also be eliminated, and needleless systems should be used.

11.3.12 Engineering Control

Engineering control is used to remove a hazard or place a barrier between the worker and the hazard. This includes designing the facility, equipment and processes to eliminate or minimize the hazards; substituting the processes, equipment, devices, materials or other factors to lessen the hazards; isolating the hazard by enclosing the source or putting barriers between the source of hazard and the exposed workers; using interlocks, machine guards, blast sheets, protective curtains and/or other means; removing or redirecting the hazard using local exhaust ventilation; and adopting complete mechanization or computerization.

Well-designed engineering controls can be highly effective in protecting workers and are typically independent of worker interactions. The initial cost of engineering controls can be higher than the cost of administrative controls or PPE, but over the long term, operating costs are frequently lower, and in some instances, can provide cost savings in other areas of the process.

11.3.13 Administrative Control

Policies to limit exposure to a hazard (e.g., universal precautions). Includes assessment of risks, medical controls including provision of PPEs, establishment of waste management policies, procedures, guidelines, and activities, conduct of regular and effective training, management of human resources and procurement of appropriate equipment and supplies. Administrative controls and PPE are frequently used with existing processes where hazards are not particularly well controlled. While relatively inexpensive to establish, it can be very costly to sustain over the long term.

Examples include allocation of resources demonstrating a commitment to staff safety, an infection-control committee, an exposure control plan, replacement of all unsafe devices and consistent training on the use of safe devices. These methods for protecting workers have also proven to be less effective than other measures, requiring significant effort by the affected workers. Medical control includes written policies with standard operating procedures on the following:

- Patient Safety which includes proper patient identification, assurance of blood safety, safe clinical and surgical procedures, provision and maintenance of safe quality drugs and technology, strengthening of infection control, maintenance of environment care standards and energy/waste management standards. Administrative Order 2008-0023 of the DOH requires Patient Safety program to have the key elements of leadership, institutional development, reporting system, feedback and communication, adverse event prevention and risk management, disclosure of reported serious events, professional development, and a patient centered care and empowerment.

- Occupational Health and Safety which includes physical examination (pre-employment and annual), regular immunization, health education and wellness, and continuous medical monitoring and periodic evaluation of safety measures.

11.3.14 Work Practice Controls

These are controls that reduce exposure to occupational hazards through the behavior of workers. Examples include no needle recapping, placing sharps containers at eye level and at arm's reach, emptying sharps containers before they are full, and arranging for the safe handling and disposal of sharps devices before beginning a procedure.

11.3.15 Personal Protective Equipment (PPE)

This refers to specialized clothing or equipment worn by a worker designed to protect against infectious materials or from exposure to infectious agents thus, preventing injury or illness from a specific hazard. Adequate and appropriate PPE shall be provided to HCF workers who are exposed to hazardous waste. This includes protection for the whole body – head, face, body, arms, legs, and feet.

The most effective PPE in reducing risk of injury are gloves to protect from exposure to blood, other potentially infectious materials, and chemicals; particulate masks (respirators) to protect from respiratory infections hazards and particulates from burning waste; and boots for waste handlers to protect from sharps injuries to the foot. Availability and access to soap and water, and alcohol hand rub, for hand hygiene are also important to maintain cleanliness and inhibit the transfer of infection via dirty hands.

Box 41: Required PPEs for health care workers

The type of protective clothing used will depend to an extent upon the risk associated with the HCW, but the following should be made available to all personnel who collect or handle waste:

Obligatory

- disposable gloves (medical staff) or heavy-duty gloves (waste workers)
- industrial aprons
- overalls (coveralls)
- leg protectors and/or industrial boots

Depending on type of operation

- eye protectors (safety goggles)
- face masks (if there is risk of splash into eyes)
- helmets, with or without visors.

Industrial boots and heavy-duty gloves are particularly important for waste workers. The thick soles of the boots offer protection in the storage area, as a precaution from spilt sharps, and where floors are slippery. If segregation is inadequate, needles or other sharps items may have been placed in plastic bags; such items may also pierce thin-walled or weak plastic containers.

If it is likely that HCW bags will come into contact with workers' legs during handling, leg protectors may also need to be worn.

Source: *Safe Management of Wastes from Health-Care Activities, 2nd Edition (WHO, 2014)*



HCF workers should know the correct usage and maintenance of the equipment. PPE shall conform to established standards. Training on PPE shall include:

- Description on the type of hazard and the condition of the work environment – determination of waste management concerns, working conditions, materials, equipment, and substances used, the exposed populations and conditions of exposure, taking into account the adverse effects on human health and to the environment.
- Explanation on why a certain type of PPE has been selected – based on the hazards present, the type of materials used and the manner in which they will be handled.
- Explanation on its proper use, maintenance, and storage – PPE shall be kept safe and in good condition. Defective PPE shall be discarded. Since PPEs have limitations and useful life, these must be regularly inspected for its effectiveness.

11.4 Hospital Hygiene and Infection Control

Management of HCW is an integral part of hospital hygiene and infection control. HCW can be considered as a reservoir of pathogenic microorganisms, which – if someone is exposed – could give rise to an avoidable infection. If waste is inadequately managed, these microorganisms can be transmitted by direct contact, by inhalation or by a variety of animal vectors (e.g., flies, rodents, roaches), which could come into contact with waste.

A basic infection-control principle is to know the chain of infection and identify the most effective points to prevent potential disease transmission. Transmission of infectious diseases in an HCF requires at least six elements: an infectious agent, a reservoir, a portal of exit, a means of transmission, a portal of entry, and a susceptible host. This concept has been discussed in **Chapter 3** of this Manual.

11.4.1 Epidemiology of nosocomial infections

Nosocomial infections (also known as hospital-acquired infections, hospital-associated infections, and hospital infections) are infections that are not present in the patient at the time of admission to the HCF but develop during the course of the patient's stay.

Nosocomial infections occur as a result of medical procedures performed on patients that lead to infections from a patient's own (endogenous) flora or as a result of exposure to items contaminated with infectious agents. Additionally, the risk of acquiring an infection increases for patients with altered or compromised immunity.

11.4.1.1 *Transition from exposure to infection*

Whether an infection will develop after an exposure to microorganisms depends upon the interaction between the microorganisms and the host. Healthy individuals have a normal general resistance to infection. Patients with underlying disease, newborn babies and the elderly have less resistance and are at greater risk to develop an infection after exposure.

Local resistance to infection also plays an important role: the skin and the mucous membranes act as barriers in contact with the environment. Infection may occur when these barriers are breached. Local resistance may also be overcome by the long-term presence of an irritant, such as a cannula or catheter. The likelihood of infection increases daily when a patient has a catheter attached.

The most important determinants of infection are the nature and number of the infectious agents. Microorganisms range from the completely innocuous to the extremely pathogenic; the former will never cause an infection even in immunocompromised individuals, while the latter will cause an infection in virtually every case of exposure.

When only a few organisms are present, an infection will not necessarily develop. However, when a critical number is exceeded, it is very likely that an infection will become established. For every type of microorganism, the minimal infective dose can be determined. This is the lowest number of bacteria, viruses or fungi that cause the first clinical signs of infection in a healthy individual. For most causative agents of nosocomial infections, the minimal infective dose is relatively high.

11.4.1.2 Sources of infection

In an HCF, the sources of infectious agents may be the personnel, the patients, or the inanimate environment.

- The hospital environment can be contaminated with pathogens. *Salmonella* or *Shigella* spp., *Escherichia coli* O157:H7 or other pathogens may be present in the food and cause an outbreak.
- Waterborne infections may develop if the water-distribution system breaks down.
- Pharmaceuticals may become contaminated during production or preparation; an outbreak of infection by *Pseudomonas aeruginosa*, *Burkholderia cepacia* or *Serratia marcescens* may occur as a consequence.
- The source of a nosocomial infection may also be a health care worker who is infected or colonized (a carrier) with an infectious agent.
- The source of most hospital epidemics is infected patients; that is, patients infected with pathogenic microorganisms are often released into the environment in very high numbers exceeding the minimal infective dose, and exposing other patients, who subsequently develop hospital-acquired infections.

11.4.1.3 Routes of transmission

In health care settings, the main modes of transmission from a source to a new host are as follows:

- Contact Transmission
 - Direct contact (e.g., a surgeon with an infected wound on a finger performs a wound dressing);
 - Indirect contact (e.g., secretions transferred from one patient to another via hands in contact with a contaminated waste item);
 - Fecal–oral via food
- Bloodborne Transmission
 - Blood is transferred via sharps or needle stick injuries, transfusion, or

injection.

- Droplet Transmission
 - Infectious droplets expelled into the air or onto a surface (e.g., when sneezing, coughing, vomiting); the droplets are too heavy to remain in suspension in the air and typically fall <2 meters from the source;
 - Direct droplet transmission – droplets reach mucous membranes or are inhaled;
 - Droplet-to-contact transmission – droplets contaminate surfaces/hands and are transmitted to another site (e.g., mucous membranes); indirect droplet transmission is often a more efficient transmission route than direct transmission (examples are the common cold, respiratory syncytial virus)
- Airborne Transmission
 - Small particles carrying microbes are transferred as aerosols via air currents for >2 meters from the source (e.g., droplet nuclei or skin scales); direct airborne transmission can be from particles in suspension in air (e.g., varicella zoster) or from deposition on to contaminated wounds (e.g., staphylococcus aureus) (Siegel et al., 2007).
- Vector Transmission
 - Typical in areas where insects, arthropods and other pests are widespread; these vectors become exposed to a disease organism (such as on the feet of flying insects) through contact with excreta or secretions from an infected patient and transmit the infective organisms directly to other patients.

11.4.2 Prevention of Nosocomial Infection

Two basic principles govern the main control measures to prevent the spread of nosocomial infections in HCFs: 1) Separate an identified source of infection from other patients and medical areas; and 2) Eliminate all obvious routes of transmission.

The separation of the source has to be interpreted in a broad sense. It includes the isolation of infected patients and implements aseptic conditions by introducing measures intended to act as a barrier between infected or potentially contaminated tissue and the environment, including other patients and medical staff.

11.4.2.1 Standard Precautions

These should be taken with every patient, independent of any known condition (e.g., infected or colonized), to protect health care workers from exposure to infectious disease. It is impossible to avoid all contact with infected tissue or

potentially contaminated body fluids, excreta, and secretions. Even when they are not touched with the bare hands, they may come in contact with instruments, containers, linen or similar items.

11.4.2.2 Isolation

The first measure in preventing the spread of nosocomial infections is the isolation of infected patients. Maintaining isolation is expensive, labor-intensive, and usually inconvenient for both patients and health care personnel. Its implementation should be adapted to the severity of the disease and to the causative agent.

11.4.2.3 Cleaning

Cleaning is one of the most basic measures for maintaining hygiene in the health care environment. It is essentially a mechanical process whereby the dirt is dislodged from a surface, suspended, or dissolved in a water film, diluted until it is no longer visible, and rinsed off. Soaps and detergents act as solubility-promoting agents. Cleaning should be carried out in a standardized manner and preferably by automated means that will guarantee an adequate level of cleanliness. Diluting and removing the dirt also removes the breeding ground or culture medium for bacteria and fungi. Most non-sporulating bacteria and viruses survive only when they are protected by dirt or a film of organic matter; otherwise, they dry out and die.

11.4.2.4 Sterilization and disinfection

The effectiveness of disinfection and sterilization is increased by prior or simultaneous cleaning. Self-evidently, an object should be sterile (i.e., free of microorganisms) after sterilization. However, sterilization is never absolute; by definition, it reduces the number of microorganisms by a factor of more than 10⁶ (i.e., more than 99.9999% of microorganisms are killed).

The term "disinfection" is difficult to define, because the activity of a disinfectant process can vary widely. The guidelines for environmental infection control in HCFs (CDC, 2003) allow the following distinctions to be made:

- High-Level Disinfection: can be expected to destroy all microorganisms, except for large numbers of bacterial spores;
- Intermediate Disinfection: inactivates *Mycobacterium tuberculosis*, vegetative bacteria, most viruses, and most fungi; does not necessarily kill bacterial spores;
- Low-Level Disinfection: can kill most bacteria, some viruses, and some fungi; cannot be relied on to kill resistant microorganisms such as tubercle bacilli or bacterial spores.

There is no ideal disinfectant, and the best compromise should be chosen according to the situation. A disinfectant solution is considered appropriate when the compromise between the antimicrobial activity and the toxicity of the product

is satisfactory for the given application. The principal requirements for a good antiseptic are absence of toxicity, rapid action, and adequate activity on natural flora and pathogenic bacteria and other microorganisms after a very short exposure time. Essential requirements for a disinfectant are somewhat different. There must be adequate activity against bacteria, fungi and viruses that may be present in large numbers and protected by dirt or organic matter. In addition, since disinfectants are applied in large quantities, they should be of low ecotoxicity. In general, use of the chosen disinfectant, at the appropriate concentration and for the appropriate time, should kill pathogenic microorganisms, rendering an object safe for use in a patient, or rendering human tissue free of pathogens to exclude cross-contamination. An overview of the list of different disinfectants are given on **ANNEX B 6**.

11.4.3 Measures for Improving Infection Control

Infection control can be improved in three ways: 1) avoiding wasteful practices; 2) using good infection-control practices; and 3) using good cost-effective practices.

Table 10: Ways to improve infection control

Eliminate Wasteful Practices That Just Increase Costs	Use Good, No-Cost Infection Control Practices	Use Good, Low-Cost Infection Control Practices
<p>Avoid:</p> <ul style="list-style-type: none"> • routine swabbing of health care environment to monitor standard of cleanliness • routine fumigation of isolation rooms with formaldehyde • routine use of disinfectants for environment cleaning, e.g., floors and walls • inappropriate use of PPE in intensive-care units, neonatal units and operating theatres • use of overshoes, dust-attracting mats in the operating theatres, and intensive-care and neonatal units • unnecessary intramuscular and intravenous (IV) injections • unnecessary insertion of invasive devices (e.g., IV lines, urinary catheters, nasogastric tubes) • inappropriate use of antibiotics for prophylaxis and treatment • improper segregation and disposal of clinical waste 	<p>You should:</p> <ul style="list-style-type: none"> • use aseptic technique for all sterile procedures • remove invasive devices when no longer needed • isolate patients with communicable diseases or a multidrug-resistant organism on admission • avoid unnecessary vaginal examination of women in labor • minimize the number of people in operating theatres • place mechanically ventilated patients in a semi-recumbent position 	<p>You should:</p> <ul style="list-style-type: none"> • provide education and practical training in standard infection control (e.g., hand hygiene, aseptic technique, appropriate use of PPE, use and disposal of sharps) • provide hand-washing material throughout the HCF (e.g., soap and alcoholic hand disinfectants) • use single-use disposable sterile needles and syringes • use sterile items for invasive procedures • avoid sharing multi-dose vials and containers between patients • ensure equipment is thoroughly decontaminated between patients • provide hepatitis B immunization for health care workers • develop a post-exposure management plan for health care workers • dispose of sharps in robust containers

Source: **Safe Management of Wastes from Health-Care Activities, 2nd Edition (WHO, 2014)**

11.4.4 Minimum Approach to Hygiene and Infection Control

Infection control is a team effort. Therefore, at a minimum, a multidisciplinary infection-control committee must be organized, comprising (but not limited to): a senior physician to provide leadership; a clinical microbiologist; an infection-control nurse; an antibiotic specialist; and a director of environmental services.

The committee should set clear aims that are time specific and measurable, and that target a specific population of patients, location, or employees. Aims could include implementing a hand hygiene program and implementing an environmental cleaning and disinfection program. In summary, the minimum approach to good hospital hygiene and infection control includes:

- setting modest aims;
- establishing baseline rates;
- implementing evidence-based interventions shown to be effective elsewhere;
- carrying out daily process surveillance (or clinical audit) throughout the project period to monitor compliance with the interventions by staff;
- measuring rates again at the end of the project period;
- if desired improvements have not occurred, analyzing the reasons (e.g., poor compliance with the interventions); and
- implementing necessary changes and repeating the cycle.

11.5 Occupational Health and Safety Program

11.5.1 Immunization

A. Pre-employment Immunization

HCF workers shall be given immunization to prevent or ameliorate the effects of infection by many pathogens such as virus causing hepatitis B and tetanus infection. Many HCF workers are at risk of exposure to and possible transmission of vaccine-preventable diseases because of their contact with infectious materials from patients such as HCW. Maintenance of immunity is therefore an essential part of the prevention and infection control programs for HCF workers.

B. Post-exposure Prophylaxis (PEP)

Post-exposure prophylaxis (PEP) is short-term antiretroviral treatment (for HIV) or immunization (for hepatitis B) to reduce the likelihood of infection after potential exposure. Within the health sector, PEP should be provided as part of a comprehensive universal precautions package that reduces staff exposure to infectious hazards at work. PEP for HIV comprises a set of services to prevent

development of the infection in the exposed person. These include first-aid care; counselling and risk assessment; HIV blood testing; and, depending on the risk assessment, the provision of short-term (28 days) antiretroviral drugs, with follow-up and support. Most incidents linked to occupational exposure to bloodborne pathogens occur in HCFs.

Box 42: Summary of PEP recommendations

The WHO and the International Labor Organization have published guidelines on PEP to prevent HIV infection. A summary of PEP recommendations from these guidelines are as follows:

- *PEP should be provided as part of a package of prevention measures that reduce staff exposure to infectious hazard.*
- *PEP should be available to health care workers and patients.*
- *Occupational PEP should also be available to all workers who could be exposed while performing their duties (such as social workers, law enforcement personnel, rescue workers, refuse collectors).*
- *Countries should include occupational PEP in national health care plans.*

11.5.2 Hand Hygiene

The hands of health care workers are the most frequent transmission route for nosocomial infections. Hand hygiene, both hand washing and hand disinfection, should be seen as the primary preventive measure that is the responsibility of all health care personnel. Provision for washing facilities (with soap and warm water) and instruction shall be made available at the point needed to ensure that proper handwashing is observed.

Thorough hand washing with adequate quantities of water and soap removes more than 90% of the transient (i.e., superficial) flora, including all or most contaminants. An antimicrobial soap will further reduce the transient flora, but only if used for several minutes. Hand washing with (non-medicated) soap is essential when hands are dirty and should be routine after every physical contact with a patient. Killing all transient flora within a short time (a few seconds) necessitates hygienic hand disinfection: only alcohol or alcoholic preparations act sufficiently fast. Hands should be disinfected with alcohol when an infected tissue or body fluid is touched without gloves.

The WHO guidelines on hand hygiene in health care (WHO, 2009) include a recipe for alcohol hand rub. The WHO (2009) guidelines also include the following guidance for hand washing and use of alcohol-based hand rubs:

- If hands are not visibly soiled, use an alcohol-based hand rub for routine antisepsis (hygienic hand disinfection). Rub until hands are dry.
- Wash hands before starting work, before entering an operating theatre, before eating, after using a toilet, and in all cases where hands are visibly soiled.

- Keep nails short and clean.
- Do not wear artificial fingernails, nail polish or jewelry.
- Do not wash gloves between uses with different patients.
- Multiple-use cloth towels of the hanging or roll type are not recommended for health care establishments.
- When bar soap is used, soap racks that facilitate drainage and only small bars should be used; liquid detergents in dispensers are preferred.
- To prevent contamination, do not add soap to a partially empty liquid-soap dispenser. Empty the dispenser completely and clean it thoroughly before refilling.
- Hand hygiene products should have low skin irritation, particularly in multiple-use areas, such as intensive care or operating rooms.
- Ask personnel for their views regarding the tolerance of any products under consideration.
- For surgical scrub, preferably use an alcohol-based hand rub.
- When using an alcohol-based surgical hand rub, pre-wash with soap, and dry hands and forearms completely (including removal of debris from underneath the nails using a nail cleaner) once a day before starting surgery and when hands become soiled (e.g., glove perforation) or sweaty. Brushes are not necessary and can be a source of contamination. Hand washing immediately before every rub does not improve its efficacy and should be abandoned. Rub for 1–5 minutes according to the manufacturer's recommendation after application and rub until hands are dry before donning sterile gloves.
- Hands must be fully dry before touching the patient or patient's environment/equipment for the alcohol hand rub to be effective. This will also eliminate the extremely rare risk of flammability.
- Use hand lotions frequently to minimize the possibility of irritant contact dermatitis.

See **ANNEX C 2** and **ANNEX C 3** for sample information materials on proper hand rubbing and handwashing, respectively.

Box 43: “My Five Moments of Hand Hygiene” in HCF

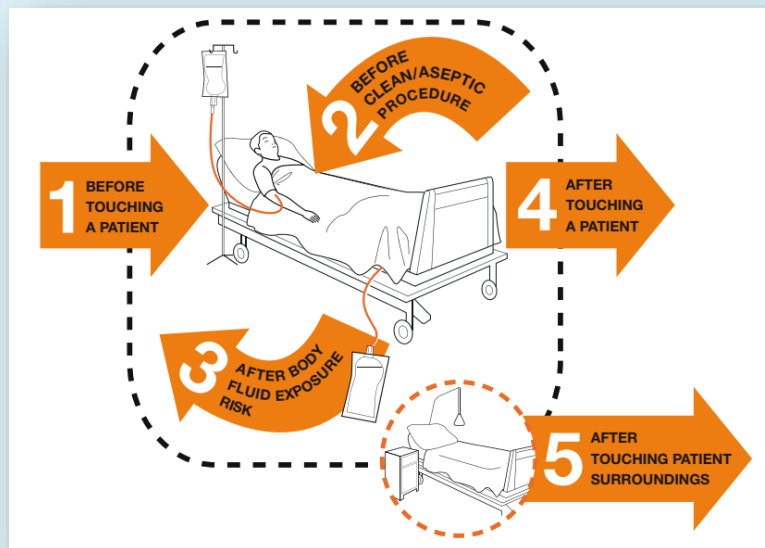

The “My Five Moments for Hand Hygiene” approach defines the key moments when health care workers should perform hand hygiene. This evidence-based, field-tested, user-centered approach is designed to be easy to learn, logical and applicable in a wide range of settings. This approach recommends health-care workers to clean their hands: 1) before touching a patient; 2) before clean/aseptic procedures; 3) after body fluid exposure/risk; 4) after touching a patient; and 5) after touching patient surroundings.

Reference: “WHO Guidelines on Hand Hygiene in Health Care” (WHO, 2009)

11.6 Education, Communication, Training and Awareness

Everyone within the HCF plays a vital role in the management of HCW, for this reason, the training program shall cast a wide network. Every HCF worker shall be made aware of the policy, the significant health and environmental impacts of their work activities, their roles and responsibilities, the procedure that apply to their work and the importance of conformance with the requirements. The worker shall understand the potential consequences of NOT following the requirements.

Training and continuing education are integral parts of the HCWM system. When health care personnel are properly sensitized to the importance of waste management, they become advocates for best practices and help to improve and sustain a good waste management system. Importantly, training should be institutionalized and become part of the standard functions of the HCF.

A training module shall be part of the Orientation/Re-orientation Program for newly hired and existing workers to ensure consistency in compliance by all HCF workers. The use of IEC materials, issuances and advisories shall be utilized to raise

awareness and ensure effective implementation of the program. The overall goals of training are to:

- a) Prevent occupational and public health exposures to the hazards associated with HCW;
- b) Raise awareness of the health, safety, and environmental issues relating to HCW;
- c) Ensure that health care personnel are knowledgeable about best practices and technologies for HCWM and are able to apply them in their daily work; and
- d) Foster responsibility among all health care workers for HCWM.

11.6.1 Training of Health Care Workers

Training is essentially the transferring of knowledge, skills, and capacity building of targeted participants. In any HCF, it is mandatory to implement education and training programs to make all the HCF workers aware of the hazards involved in HCW and their specific roles. All HCF workers shall receive training tailored to their different needs at various levels or functions in the HCF.

The overall aim of the training is to develop awareness on the health, safety and environmental issues relating to HCW, and how these can affect HCF workers in their daily work. It shall also highlight the roles and responsibilities of the HCF workers. Separate training activities shall be designed for each of the following targeted categories of personnel:

- HCF managers and administrative staff responsible for implementing regulations on HCWM;
- Medical doctors;
- Nurses and assistant nurses; and
- Cleaners, porters, auxiliary staff, and waste handlers.

The training for waste generators as well as waste handlers is equally important. Medical doctors may be educated through senior staff workshops and general hospital staff through formal seminars. The training of waste managers and regulators could take place outside the hospital at public health schools or university departments. Basic education program for HCF worker shall include:

- Information on and justification for all aspects of the HCW policy;
- Information on the role and responsibilities of each HCF worker in implementing the policy; and
- Technical instructions, relevant for the target group, on the application of waste management practices.

All HCF workers must receive initial and annual training. A trained individual must be available during training sessions. The instructors shall have experience in teaching and training and be ideally familiar with the hazards and practices of HCWM; they should also have experience in waste handling.

11.6.2 Integrating Public Education on Risk Awareness

Promotion of safe and sensible waste handling and disposal is relevant both to users of HCFs and to the wider community as one approach to achieve a better understanding of health public. All HCFs, the DOH and the EMB-DENR have the responsibility and a “duty of care” for the environment and public health.

The need to promote appropriate handling and disposal of HCW is important to public health. Every member of the HCF and the community has the right to be informed about the potential health hazards associated with HCW. Inadequate handling of HCW may have serious public health consequences and impacts on environmental health protection. Public awareness through formal or informal education plays an important role in HCWM. Development of information, education, and communication (IEC) programs and materials shall be given due course with the following objectives: 1) to transmit the basic skills and knowledge in establishing a healthy, secure, and safe environment for HCW and the general public; 2) to inform the public about the risks linked to HCW, focusing on people either living or working near or visiting HCF, families of patients being treated at home and scavengers on waste dumps; 3) to foster responsibility among hospital patients and visitors to HCF regarding hygiene and HCWM; 4) to prevent exposure to HCW and related health hazards, this exposure may be voluntary in the case of scavengers or accidental as a consequence of unsafe disposal methods; 5) to increase awareness of the impact of HCW on environment and ecology; and 6) to influence behavior of patients, watchers, HCF workers to implement proper HCWM.

In developing the education, training, information and communication tools, there are several concerns that need to be addressed. These are specific targeted subjects or participants, including their level of understanding and involvement in the implementation of the HCWM Plan; availability of funds and logistics to sustain the program; and support of the HCF management to the program. Training package suggestions for each target group are provided in **ANNEX B 9**.

Box 44: Methods of communication and training

Various methods can be used to promote public education on HCW. Commonly used approaches include the following:

- Graphics and audio-visuals which may be in the form of brochures, posters, display boards, video tapes, slides, CD/DVDs, flyers, flip charts, leaflets, etc.
- Use of tri-media such as announcements or commercial ads featured in radios, movies, television, newspaper, magazines, and the internet.
- Orientation/re-orientation seminars, training, and workshops; community and health teachings for hospital patients, watchers and other clients using IEC materials and didactic exercise.
- Issuance of written HCF policies to disseminate the information and awareness among HCF workers. There shall be corresponding sanctions to be implemented for non-compliance with issued policies.

For maximum effectiveness, all information should be displayed or communicated in an attractive manner to hold people's attention and increase the likelihood they will remember the important messages to be conveyed by an information campaign. In medical areas, general HCW bins should be easily accessible for patients and visitors, and signs should explain clearly what they should do with other categories of waste. HCFs should set an example to society by demonstrating that they are managing their waste in a manner designed to protect health and the environment.

12 Health Care Waste Management in Emergencies

Natural disasters and conflicts, by their nature, are highly disruptive and dangerous events. Their consequences are unpredictable, and it is inevitable that many essential public services will be interrupted. HCFs, public health and municipal services, such as waste management, may totally or partially cease due to destroyed buildings, damaged equipment, dislocation of staff and blocked roads.

In such situations, all forms of wastes including hazardous HCW remains uncollected and untreated. It is inevitable that wastes will accumulate, and serious environment and health hazards (e.g., hepatitis B and C) may affect communities. Therefore, measures need to be taken to remove wastes as soon as possible after an emergency. The purpose is to reduce the proximity of people to accumulated wastes and so reduce the potential for disease transmission.

12.1 Emergency Management Plan

As defined by the WHO "contingency planning and emergency preparedness is a program of long-term development activities whose goals are to strengthen the overall capacity and capability of a country to manage efficiently all types of emergency and to bring an orderly transition from relief through recovery and back to sustain development. The phases for the safe management of HCW in emergencies are described in the succeeding sub-sections.

12.1.1 Phase 1: Rapid Initial Assessment

Rapid assessments immediately following a disaster or other emergency are designed to be swift and to inform emergency responders about critical and immediate needs. An initial rapid assessment is likely to be unrefined and should be updated as more data become available. An assessment team shall conduct this initial phase which may include relief or awareness activities.

To work effectively, the team shall have a clear-cut disposition and priority whether to gather information or perform relief actions. Personnel carrying out assessments are likely to provide initial advice and awareness-raising activities simultaneously. However, a pragmatic balance must be found between the need to act quickly and the need to gather sufficient information to ensure assistance is effective, appropriate to the problems found and sustainable into the future.

Issues to remember when collecting information in emergencies:

- Collect information from as many sources as possible to reduce bias and inaccuracies;

- Be aware of local conditions so as not raise unrealistic expectations;
- Use the data collected as evidence to inform the decisions that must be made;
- Keep good records of what has been learned and from whom; and
- Situations change rapidly in an emergency, and the solutions proposed should be robust and flexible.

More detailed assessments are required during the later disaster management phases as the needs and capabilities of local communities and public organizations evolve. The purpose is to prepare the contributors to the wider relief effort to change over from short-term initial response activities to longer term rehabilitation.

Table 11: Key issues in rapid initial assessment

Aspect	Key Issues
General information	<ul style="list-style-type: none"> • Nature and history of the emergency • Organization carrying out the assessment • Name and position of assessors • Dates of the assessment • Location of the affected area • Logistical resources available • Government involvement • Existing potential donors • Other organizations working in the area, including current and planned activities • Institutions and NGOs providing emergency medical care • Existing policies, regulations, or guidelines on HCW management • Locations and nature of emergency medical care interventions (in tents, field hospitals, mobile HCFs, non-damaged hospitals and health care centers, HCFs outside of the affected area)
Demographic data	<ul style="list-style-type: none"> • Total population in the affected area • Approximate number of affected people
Geographical information	<ul style="list-style-type: none"> • A sketch should be produced, and the following features identified and located: <ul style="list-style-type: none"> ○ Location and type of existing operational medical care activities ○ Location and type of existing operational waste treatment and disposal facilities ○ Burial or cremation sites ○ Location of emergency dumping of HCW ○ If possible, groundwater water levels near the locations of the operational health care operations
General description of the management of HCW in the affected area	<ul style="list-style-type: none"> • The categories of HCW generated by medical care activities • Provide any information about HCW quantities. If none exists, make a rough estimation • Describe the process of HCW handling in the location of the emergency medical activities • Describe the type and number of waste-related equipment available for managing HCW • Explain how HCW is disposed • Identify any sites near the emergency health care activities for controlled burial of HCW • Identify who is involved in the handling and disposal of HCW • Identify financial resources allocated for handling and disposal of HCW • Describe any reported injuries related to HCW (e.g., sharps injuries)

Source: Safe Management of Wastes from Health-Care Activities, 2nd Edition (WHO, 2014)

12.12 Phase 2: Emergency Response

Based on the rapid initial assessment, a simple action plan with clear roles and responsibilities for individuals and emergency response organizations (international bodies, national authorities, civil society) can be developed and resources allocated from the aid effort for implementation. The purpose of HCWM in an emergency is to avoid wastes from being scattered indiscriminately around medical buildings and their grounds and reduce the likelihood of secondary infections.

As a basic starting point and to avoid sharps injuries, HCW generated by emergency medical care activities (in tents, field hospitals, mobile hospitals) should be segregated using a “two-bin solution” – that is, sorting waste into used sharps and non-sharps wastes (including general wastes and infectious, pathological and pharmaceutical residues). The two bins should be kept segregated until final disposal.

Basic considerations in emergency response in HCWM:

- All non-sharps wastes, without exception, should be collected in medical areas in rigid containers, such as plastic buckets with a cover, to prevent waste items from being exposed to disease transmission by contact by hand, airborne particles, and flying insects.
- Containers and covers should be washed and disinfected daily after being emptied.
- Reuse of rigid waste containers after disinfection with a chlorine (0.2%) solution may be the most practical option to introduce quickly in an emergency and is low cost at a time when resources for better forms of waste segregation and storage may be scarce.
- Sharps wastes should be stored safely in puncture-proof and leak-proof containers.
- Burial of non-sharps and sharps wastes in pits or trenches may be considered as a pragmatic option in emergency situations. Burning of HCW is less desirable, but if it is genuinely the only realistic option in an emergency it should be undertaken in a confined area (burning within a dugout pit, followed by covering with a layer of soil).

The following preventive measures can also be implemented during an emergency response phase to reduce public and occupational health risks:

- Provide hepatitis B vaccination to all health care personnel and waste handlers;
- Encourage hand hygiene (washing, preferably followed by disinfection);
- Use gloves for handling HCW;
- Raise the awareness of staff about simple post exposure prophylaxis in the

event of an occupational injury (e.g., needle-stick injury);

- Contain and promptly clean up spillages of infectious materials and disinfect quickly to avoid pathogen transmission;
- Disinfect body fluids before their discharge; and
- Conduct on-site awareness-raising activities (whenever possible) to remind health care personnel about occupational exposures and the safe practices for managing HCW.

As an emergency response progresses and more aid resources become available, the management of HCW can be improved by establishing a three-bin system (see **Box 23**).

Table 12: Segregation of HCW in emergencies

Waste Category	Typical Waste Items	Type of Container	Color or Mark/Sign
Non-sharps wastes	Infectious, pathological waste and some pharmaceutical and chemical residues	Leak-proof container or plastic bag in a holder	Yellow or special mark or sign
Used sharps	Syringes with needles, sutures, blades, broken glass	Leak- and puncture proof sealable container, box or drum bearing the word "contaminated sharps"	Yellow or special mark or sign
General waste	Similar to municipal wastes, not contaminated by hazardous substances	Container or plastic bag in a holder	Black or special mark or sign

Source: Safe Management of Wastes from Health-Care Activities, 2nd Edition (WHO, 2014)

Segregated waste should be kept separated until final disposal. General waste should follow a municipal waste disposal route, if available, and sharps and non-sharps wastes should be treated and disposed of using the best available practices based on the minimum options described in the preceding chapters of this Manual.

12.1.2.1 Minimum treatment and disposal options

A. On-site burial in pits

Dig a pit 1–2 meters wide and 2–3 meters deep. The bottom of the pit should be at least 2 meters above the groundwater. Line the bottom of the pit with clay or permeable material. Construct an earth mound around the mouth of the pit to prevent water from entering. Construct a fence around the area to prevent unauthorized entry. Inside the pit, place alternating layers of waste, covered with 10cm of soil (if it is not possible to layer with soil, alternate the waste layers with lime). When the pit is within about 50cm of the ground surface, cover the waste with soil and permanently seal it with cement and embedded wire mesh. See **ANNEX E 9** for illustration of pit construction for on-site waste burial.

B. Burial in special cells in dumping sites (if available in the affected area)

Cells to contain waste can be used when burying waste in dumping sites. The cell should be at least 10 meters long and 3 meters wide, and 1–2 meters deep. The bottom of the cell should be at least 2 meters above the groundwater. The bottom of the cell should be covered by soil or a material with low permeability. The waste in the cell should be covered immediately with 10-cm layers of soil to prevent access by people or animals (in diseases outbreaks, preferably spread lime on waste before covering with the soil). It is strongly recommended that HCW be transported in a safe manner to minimize public exposure to bio-contaminated wastes.

C. Low-cost double-chamber incinerators

Double-chamber incinerators may reach a temperature of about 800°C with a residence time of more than one second in the second chamber to kill pathogens and break down some of the particulates in the outlet gases. The incinerators should be built at a convenient distance away from buildings. Such incinerators need to be heated with paper, wood, or dry non-toxic waste (small quantities of kerosene may be added, if available) before adding infectious wastes.

D. Encapsulation

Place sharps wastes or pharmaceutical wastes in hard containers, such as metal drums, and add an immobilizing material, such as cement, bituminous sand, or clay. When dry, the drum or container can be sealed and buried in local landfill or a pit in the HCF.

Table 13: Summary of pharmaceutical disposal methods in and after emergencies

Disposal Method	Type of Pharmaceutical	Comments
Return to donor or manufacturer, transfrontier transfer for disposal	All bulk waste pharmaceuticals, particularly antineoplastics	Usually not practical- transfrontier procedures may be time consuming
Highly engineered sanitary landfill	Limited quantities of untreated solids, semi-solids and powders PVC plastics	Immobilization of waste pharmaceuticals is preferable before disposal
Engineered landfill	Waste solids, semi-solids and powders PVC plastics	Immobilization of solids, semi-solids and powders is preferable before disposal
Open, uncontrolled, non-engineered dump	Untreated solids, untreated semi-solids and untreated powders	As last resort, untreated solids, semi-solids and powders must be covered immediately with municipal waste Immobilization is preferable before disposal.; Not for untreated controlled substances
Immobilization: waste encapsulation or inertization	Solids, semi-solids, powders, liquids, antineoplastics and controlled substances	Immobilization: not applicable; Chemical decompositions are not recommended unless special expertise and materials are available
High-temperature incineration (>1200°C)	Solids, semi-solids, powders, antineoplastics and controlled substances	Expensive, particularly for purpose-built incinerators; Use of existing industrial plants may be more practical
Medium-temperature incineration with two-	In the absence of high-temperature incinerators,	Antineoplastics best incinerated at high temperatures

Disposal Method	Type of Pharmaceutical	Comments
chamber incinerator, min. temperature of 850°C	solids, semi-solids, powders and controlled substances	
Burning in open containers	Packaging, paper and cardboard	As last resort; Not acceptable for PVC plastics or pharmaceuticals
Sewer or fast-flowing watercourses	Diluted liquids, syrups, intravenous fluids, small quantities of diluted disinfectants (supervised)	Not recommended for antineoplastics, undiluted disinfectants or antiseptics
Chemical decomposition	NA	Not recommended unless special expertise and materials are available Not practical for quantities of more than 50kg

Source: Safe Management of Wastes from Health-Care Activities, 2nd Edition (WHO, 2014)

Table 14: HCWM practice in emergencies

Aspect	Measures
Segregation and packaging	<ul style="list-style-type: none"> All containers and bags should be filled to three-quarters of their capacities to avoid spillage and kept covered to prevent casual access by people or disease vectors. Should color coding of plastic bags and containers not be possible, signs or marks can be put on containers to differentiate between hazardous HCW and general waste. Segregated waste should be regularly removed and safely stored to reduce the risk of transmission of pathogens and improve general standards of cleanliness and hygiene in medical areas. If plastic bags are not available, containers for non-sharps wastes should be washed and disinfected after being emptied. Body parts should be safely stored and disposed of according to local culture and customs.
Collection	<ul style="list-style-type: none"> Exclusively allocated carts or trolleys with lids should be used to collect and transport HCW. Carts should be regularly cleaned and disinfected. Highly infectious wastes (e.g., laboratory wastes and wastes from persons with contagious diseases) should be collected quickly and carried to a single, secure central storage area; on no account should collected waste be left anywhere other than at a central storage point.
Storage	<ul style="list-style-type: none"> Segregated waste should preferably be stored in specific restricted areas. The storage area should be a locked room or guarded enclosure. If this is not available, large containers with lids may be used for temporary storage of segregated waste and should be placed in restricted areas to minimize contact with people and animals. Mark the storage area with the biohazard symbol or put a sign or mark that is understood locally to differentiate between hazardous and non-risk wastes.
Treatment and Disposal	<ul style="list-style-type: none"> Should resources not be available, minimal treatment and disposal practices should continue to be used as follows: <ul style="list-style-type: none"> onsite burial in pits or trenches; disposal in special cells in municipal dumping sites; burning in pits and then covering with soil; incineration in low-cost double-chamber incinerators; encapsulation of sharps waste or small quantities of pharmaceuticals followed by onsite burial or burial in special cells in municipal dumping sites; incineration in high-temperature industrial incinerators (provided that there is a safe means of transportation); disinfection of infectious and sharps wastes with a small autoclave

Aspect	Measures
	(when resources are available); non-sharps disinfected wastes should join the general waste stream.
Source: Safe Management of Wastes from Health-Care Activities, 2nd Edition (WHO, 2014)	

12.1.2.2 Spill control

Spillages require clean-up of the area contaminated by the spilt waste. For spillages of highly infectious material, it is important to determine the type of infectious agent, because immediate evacuation of the area may be necessary in some cases.

In general, the most hazardous spillages occur in laboratories rather than in medical care departments. The Infection Control Officer can be asked for assistance regarding proper management and clean-up of the spill due to infectious waste.

Procedures for dealing with spillage (refer to **ANNEX C 4** and **ANNEX C 5**) shall specify safe handling operation and appropriate protective clothing. In case of skin and eye contact with hazardous substance, there shall be immediate decontamination. The exposed person shall be removed from the area of the incident for decontamination, generally with copious amounts of water. Special attention shall be paid to the eyes and any open wounds. In case of eye contact with corrosive chemicals, the eyes shall be irrigated continuously with clean water for 10 – 30 minutes; the entire face shall be washed in a basin, with the eyes being continuously opened and closed. An eye wash assembly can be installed in the unit for immediate response.

Emergency response procedures for specific waste spills are provided in **ANNEX C 6**.

12.1.3 Phase 3: Recovery Phase

The recovery phase can be characterized as a longer-term program of assistance to return an affected community to a normal situation similar to that which existed before the disaster or, potentially, better. As resources become available, a more detailed assessment can be conducted for planning and fundraising for future improvements, and for setting priorities in the affected area.

The results of the assessment and the identified needs and priorities are the starting point for ensuring that a sustainable approach to HCWM is created after an emergency. Start by preparing simple, locally applicable action plans to define the improvements to be achieved, and gradually improve these action plans whenever the resources become available. Key points to address during a recovery phase:

- Existing procedures and practices of HCWM;
- Responsibility for the management of HCW;
- Presence of an infection-control committee to oversee improvements and training;
- Dedicated equipment for storage, collection, and on-site and off-site

transportation of HCW;

- Availability of on-site and off-site HCW treatment facilities;
- Availability of on-site and off-site disposal facilities;
- Level of health care personnel awareness about the risks associated with HCW;
- Staff health protection (protective clothing, vaccination); and
- Financial aspects related to HCWM and associated infection-control procedures, and a means to sustain funds to operate waste management in the future.

Recovery phase activities in the HCF after an accident, incident and emergencies can include the following:

- Preparation of incident/accident report (Refer to **ANNEX D 6** for a sample Occupational Incident/Accident Report (OIR) Form);
- Inventory of used items;
- Provision of new supplies to replace the used items in the kit; and
- Psychosocial debriefing of the injured person, as necessary.

All waste management staff should be trained in emergency response and made aware of the correct procedure for prompt reporting. Accidents or incidents, including near misses, spillages, damaged containers, inappropriate segregation, and any incidents involving sharps, should be reported to the WMO (if waste is involved) or to another designated person. The report should include details of:

- The nature and magnitude of the accident or incident;
- The place, date and time of the accident or incident;
- The staff who is directly involved;
- Immediate response taken;
- Any other relevant circumstances; and
- Recommendations, if any.

The WMO or other responsible officer, who shall take possible action to prevent recurrence, shall investigate the cause of the accident or incident. The records of the investigation and recommendations must be submitted to the management for review and approval. Any amendment in the policies and procedural guidelines must be integrated in the HCWM Plan of the HCF. Updates shall be disseminated to all HCF workers for information and guidance. All records of spill management must be kept for future reference. A sample flowchart on the management of occupational accident/incident for tertiary hospitals is provided in **ANNEX A 9**.

There shall be an established reporting system in all HCWM-related incidents. A clear investigating system must be ensured, and effective corrective action must be employed.

12.2 Contingency Planning and Emergency Preparedness

At the HCF level, action plans on HCWM should include temporary measures to apply during emergency situations.

The contingency plans should address the following questions:

- What standards will be used to guide a response?
- What are the current capacities of the agencies or organizations to respond?
- What initial assessment arrangements are needed?
- What actions will be taken as an immediate response to the situation?
- Who does what and when? Who is coordinating and leading?
- What resources would be needed?
- How will information flow between the various levels (local and national)?
- Have specific preparedness actions be agreed on and practiced?

Contingency planning needs to be seen as a continuing process that is regularly reviewed and updated to ensure that all partners are familiar with their various roles, responsibilities and actions to be undertaken. Contingency plans should be in line with existing national policies and legislation.

Box 45: Emergency contingency plan for HCW transporter

The development of a plan of action shall be considered in the event of an accidental spill, loss of containment, equipment failure or other unexpected circumstances. The owner/operator of vehicles used in the transport of HCW shall carry contingency plans for emergencies that address the following:

- *Emergency response intervention cards (ERICards or ERICs) kept inside the driver's cab provide guidance on initial actions for responders and fire crews, because they are often the first to arrive at the scene of a hazardous waste transport accident. These cards provide reliable product-specific emergency information that otherwise may not be immediately available. Sample is provided in ANNEX --- of this Manual.*
- *Plan for the disinfection of the truck and any contaminated surface if a leaking container is discovered.*
- *A notification list of individuals or agencies to be contacted in the event of a transport accident.*
- *Clean-up and decontamination of potentially contaminated surfaces, designation of back-up transport for the HCW, a description of the plans for the repackaging and labelling of HCW where bins are no longer intact.*
- *Procedures for the management of leaking container/s.*
- *Other EMB-DENR requirements.*

12.3 Emerging Issues

12.3.1 Emerging Diseases and Multidrug-resistant Organisms

Among the most important diseases are those becoming increasingly resistant to the established medical treatments. These include extremely drug-resistant tuberculosis, methicillin-resistant and vancomycin-resistant *Staphylococcus aureus*, and malaria (chloroquine-resistant *Plasmodium falciparum*, and strains that are resistant to the antifolate combination drugs and to atovaquone). *Clostridium difficile* too has recently caused much concern as a resistant nosocomial infection (Loo et al., 2005).

Waste-treatment practices may need to be adapted to ensure that novel organisms are inactivated properly. Standardized test strips containing heat-resistant bacterial spores are assumed to demonstrate that processes to inactivate the spores will also be effective with other pathogens. However, some pathogens – such as prions – are difficult to inactivate. Testing protocols, including test strip design, need to be updated regularly in the light of new data on pathogen resistance.

12.3.2 Pandemics

Pandemics have always occurred periodically. They may be catalyzed by factors including the increase in international travel and movement of populations or disease vectors. It is generally assumed that the amount of HCW will increase during pandemics, but if non-emergency medical operations and other treatments are postponed, the amount of wastes may be lower. The mode of transmission will be another significant factor. If a pandemic is spread by contact, even general waste from medical areas may potentially have to be classified as infectious HCW.

Where a vaccine is available, the quantity of sharps waste and empty vials will increase significantly. Fortunately, these wastes are comparatively easy to store and so should not create an insurmountable HCW problem, unless produced in underdeveloped regions. Any increase in vaccination waste may be partially offset by a reduction in routine injections. The status of waste management staff should be considered. Unlike health workers, they are generally not included in lists of essential workers who should be prioritized for vaccination. Consequently, there may be significant staff shortages and subsequent loss of capacity for waste management staff. This would be most acute where HCW treatment and disposal are conducted at centralized plants away from HCFs.

In their contingency plans to address medical emergencies, HCFs should include the use of HCW engineering advice, realistic transportation and disposal arrangements, and the regular vaccination of waste workers. This is a prudent approach to maintaining a sufficient level of public health protection through prompt waste removal and processing during an emergency.

12.3.3 Climate Change

Climate change is likely to affect all aspects of life, and waste management is no exception. Gradual climatic trends and extreme weather events can disrupt services in the short term and affect long-term capacity requirements. Waste-disposal sites are often built on marginal sites, such as marshlands, flood plains and coastal areas, and many may become increasingly vulnerable to flooding where average sea and river levels rise, or more frequent extreme weather events inundate the land.

Shorter duration weather changes, such as seasonal floods and heatwaves, may be particularly problematic in rural areas, where resilience in waste-collection systems may be lower. This can be countered by decentralizing waste treatment and increasing storage capacity, as well as undertaking contingency or continuity planning at the facility and national levels. Fuel and power costs are predicted to rise, and power shortages may become more common. Planners should promote the adoption of lower energy technologies wherever possible. Installation of renewable energy generation capacity, particularly at remote installations, would reduce vulnerability.

Table 15: Key points relating to climate change

Issues	Response Options
<ul style="list-style-type: none"> • Sea level rise and increased flooding will affect routine waste-collection and treatment services and access to sites. • Heatwaves and other extreme weather events will increase the burden on HCFs, increase waste production, and lengthen storage times for wastes before disposal. • Fuel and energy costs will increase. • Geographical disease patterns will change. • Greater health consequences will result from an increasing likelihood of more large-scale population movements. 	<ul style="list-style-type: none"> • Avoid siting waste-handling and disposal sites on locations that are vulnerable to flooding. • Ensure extra clearance during planning and design between subsurface constructions (landfills, septic systems, composting pits) and the subsurface water table. • Consider the possibility of being cut off from waste-collection services by floods when planning waste-storage and treatment needs for remote facilities. • Plan for reduced storage periods during heatwaves. • Install temperature controls in waste-storage areas, noting that extreme weather events may result in power failures. • Select low-energy waste-treatment options. • Install renewable energy sources where possible. • Reduce overall resource requirements through waste-minimization practices. • Develop contingency plans for impacts likely at facility, regional, national, and international levels.
<p>Source: Safe Management of Wastes from Health-Care Activities, 2nd Edition (WHO, 2014)</p>	

12.3.4 Other Environmental Issues

The list of pharmaceuticals, other hospital-derived chemicals and disinfection by-products present in wastewater and the environment is increasing. Their impacts on human and ecosystem health vary but are becoming more widely understood.

Overuse of antimicrobials can simultaneously drive bacterial resistance and cause pollution. Glutaraldehyde, triclosan and silver are among the best known. Silver is now found in many medical devices, soaps, textiles, furnishings, and construction materials targeted at hospitals. However, some bacteria rapidly build up resistance to silver by a mechanism that could also make them resistant to antibiotics, particularly the beta-lactams.

Resistance can also build up in bacteria in sewage treatment works and the wider environment if they are polluted with antimicrobials released from products. The only way to avoid these twin problems is through the segregation and treatment of wastes containing these antimicrobials, or their recovery from wastewaters. Since this is currently not practiced and is unlikely to be feasible in the near future, use of these products should be kept to a minimum.

Chlorine-based disinfectants are widely used. However, chlorine can cause pollution through reacting with organic chemicals in liquid wastes to create toxic organochlorines. If materials such as infected plastics have been soaked in chlorine before incineration, the amount of chlorinated dioxins and furans produced will be elevated. Alternatives that can be equally or even more effective as disinfectants include hydrogen peroxide or ozone, either alone or in combination with ultraviolet light.

Table 16: Key points relating to environmental issues

Issues	Response Options
<ul style="list-style-type: none"> • There is a need to reduce toxic chemicals in wastewater and in other emissions from HCW disposal. • Overuse of antimicrobials increases pathogen resistance. • The availability of authorized landfill capacity is decreasing, and the costs of operation are increasing. • Environmental protection requirements and costs will increase. 	<ul style="list-style-type: none"> • Prioritize pollution prevention over pollution control and avoid the use of toxic materials wherever possible. • Improve wastewater treatment and avoid disposing of chemicals to the sewer. • Avoid overuse of microbial chemicals, especially silver triclosan and glutaraldehyde. • Replace chlorine as a disinfectant with hydrogen peroxide, ozone, and ultraviolet alternatives.
<p>Source: Safe Management of Wastes from Health-Care Activities, 2nd Edition (WHO, 2014)</p>	

12.3.5 Waste Technology

The use of more complex medical procedures and the continuing trend towards single-use products in medical practice will lead to marked changes in the composition of waste. Using single-use products would necessitate disposal of the device itself and its packaging, neither of which may be recyclable. Increases in waste volumes can be guarded against by selecting reusable products where possible without compromising patient care or worker safety.

New and environmentally friendly technologies for HCW treatment include microwave and ozone for sterilizing, and alkaline hydrolysis and supercritical water oxidation for treating chemical and pharmaceutical wastes. Their implementation is

hampered by cost and sometimes a reluctance by decision-makers to invest in technologies without a history of successful operation. Another factor limiting the widespread implementation of these technologies is the paucity of models available for smaller facilities and those in remote areas.

Controlling pollution through technological means is a costly process and costs will inevitably rise as national and international pollution control legislation is tightened. Avoiding pollution through upstream measures such as better design of products will be more cost-effective. Procurement policies should favor products that are reusable or recyclable, are non-toxic and have a lower environmental impact when disposed of.

Table 17: Key points relating to waste technology

Issues	Response Options
<ul style="list-style-type: none"> • Little independent information is available on new waste-treatment technologies. • Many products are not recyclable. • Increased use of disposables will increase waste production. • Some products (e.g., polyvinyl chloride [PVC], broken mercury thermometers) produce toxic emissions if incinerated. • Technologies for low-income or remote regions need further development. 	<ul style="list-style-type: none"> • Improve information dissemination for an informed debate on technology evaluations. • Set standards for waste treatment that relate to the level of microbial inactivation required. • Phase out mercury and PVC products used in health care. • Replace disposable products with reusable and recyclable options wherever it can be achieved without affecting patient care or worker safety. • Design new products for easier reuse and recycling. • Improve segregation of wastes so that each waste stream is sent to the most appropriate waste-treatment system.
<p>Source: Safe Management of Wastes from Health-Care Activities, 2nd Edition (WHO, 2014)</p>	

12.3.6 Social, Cultural, and Regulatory Changes

As countries develop economically, populations tend to gravitate to the cities, increasing the pressure on all types of infrastructure. The movement to the cities is likely to be exacerbated by climate change, as people may be driven off the land by drought, flooding or other changes that cause the failure of previously stable environments and agricultural systems. This will also increase the possibility of conflict and cross-border migration and exert pressure on disposal systems.

The Stockholm Convention aims to eliminate pollution from persistent organic pollutants, including dioxins and furans, which are produced by the combustion process in HCW incinerators. Capacity-building plans should consider alternatives, such as autoclaving of infectious waste, which may become cheaper in the future. Regulations are also tightening on the use and disposal of mercury-containing products, PVC, diethylhexyl phthalate (DEHP), pharmaceuticals, hazardous wastes and scrapped electronic equipment. In the future, “extended producer responsibility” legislation may make more product and waste producers legally responsible for ensuring the proper disposal of many types of waste.

The range of alternatives to medical products that pose elevated pollution risks during disposal is increasing, while the cost of many is decreasing. For example, more PVC- and DEHP-free devices are being brought to market. The price of mercury-free electronic thermometers and retractable syringes has decreased significantly, and syringe manufacturers are redesigning their products to make them more easily recyclable. Careful procurement can reduce the effort and expense of waste disposal. Improved information technology also makes it easier for decision-makers to identify and source the best available technologies from across the world.

HCWM currently suffers in many areas from a lack of attention by decision-makers and a lack of funding. Hopefully, this lack will be remedied as the health and environmental benefits of proper treatment are better appreciated. Minimization of the amount and toxicity of waste should take ever greater priority at all stages of the medical product design, manufacture, procurement, use and disposal cycle. At the same time, more recycling of non-hazardous wastes and the wider use of efficient and less polluting waste-disposal practices should reduce the impact on the environment and wider community health and maintain protection from transmission of infections.

Table 18: Key points relating to social, cultural, and regulatory changes

Issues	Response Options
<ul style="list-style-type: none"> • The Stockholm Convention and other regulations may restrict incinerator use. • Hazardous chemicals will be increasingly tightly regulated. • New designs of medical equipment (e.g., retractable syringes, digital thermometers) are more costly than established products. • Pressure on health care services will increase as urban populations increase. • There will be increasing globalization of medical device manufacture and procurement. 	<ul style="list-style-type: none"> • Develop and implement non-incinerator technologies. • Build capacity for technology transfer and knowledge sharing. • Encourage health care providers to cooperate to bulk purchase improved designs of medical products that are less expensive to dispose of. • Build research collaborations to design and promote new environmentally beneficial products for the health care sector.
<p>Source: Safe Management of Wastes from Health-Care Activities, 2nd Edition (WHO, 2014)</p>	



**FOOD
LEFTOVERS**

Vegetables, Fruits, Nuts, Meat, Bones, Seeds, etc.

RESIDUALS

Hard Candy Wrappers, Teryx Pails, Cans, and Metal Pails, Cans, Etc.

PART IV – GLOSSARY, ANNEXES, AND REFERENCES

Definition of Terms

Unless otherwise specified, the following terms shall have the meaning provided for in this Manual:

<p>Ambulatory Surgical Clinic (ASC)</p>	<p>A specialized health facility that is primarily organized, constructed, renovated, or otherwise established for the purpose of providing elective surgical treatment of outpatients whose recovery, under normal and routine circumstances, will not require inpatient care. (DOH AO No. 183, s. 2004; DOH AO No. 24, s. 1994)</p> <p>See related: Specialized Health Facility.</p>
<p>Antineoplastic</p>	<p>Inhibiting the development of neoplasms or abnormal tissue growth.</p>
<p>Autoclaving</p>	<p>Method of sterilization using an equipment for effective sterilization by steam under pressure and temperature.</p>
<p>Barangay Health Station (BHS)</p>	<p>A government primary health facility that provides primary care services at the barangay level; is focused on preventive and promotive population-based health service; assists in patient navigation as a satellite health facility of the Rural Health Unit (RHU) and Urban Health Unit (UHU); and follows the standards set by the DOH. The BHS is equivalent to the Barangay Health Center of the Local Government Code of 1991. The term 'health center' is sometimes used by communities to refer to these facilities. (DOH-HFDB Health Facilities Dictionary)</p> <p>See related: Primary Care Facility.</p>
<p>Birthing Home</p>	<p>A short-stay non-hospital-based health facility that provides maternity services including prenatal and postnatal care, normal spontaneous delivery, and care of newborn babies to low-risk mothers and babies. (DOH-HFDB Health Facilities Dictionary)</p> <p>See related: Primary Care Facility.</p>
<p>Blood Service Facility (BSF)</p>	<p>A unit, agency, or institution providing blood products. The types of BSF are Blood Station (BS), Blood Collecting Unit (BCU), Hospital Blood Bank (BB), and Blood Center (BC)—regional, sub-national, and national. (DOH AO No. 2008-008)</p> <p>See related: Specialized Health Facility.</p>
<p>Clinical Laboratory</p>	<p>A health facility where tests are done on specimens from the human body to obtain information about the health status of a patient for the prevention, diagnosis, and treatment of diseases. These tests include, but are not limited to, the following disciplines: clinical chemistry, hematology, immunohematology, molecular biology, and cytogenetics. The total testing process includes pre-analytical, analytical, and post-analytical procedures. (RA 4688; DOH AO No. 2007-0027)</p> <p>a) General Clinical Laboratory—provides the following minimum service capabilities such as, but not limited to, routine hematology, qualitative platelet determination, routine urinalysis, routine fecalysis, blood typing, etc.</p> <p>b) Specialized Clinical Laboratory—offers highly specialized laboratory services that are not provided by a General Clinical Laboratory.</p> <p>See related: Diagnostic Facility.</p>
<p>Collection</p>	<p>Act of safe transporting of HCW from source or from a central storage area.</p>

Custodial Care Facility	<p>A health facility that provides long-term care, including basic human services like food and shelter to patients with chronic or mental illness, patients in need of rehabilitation owing substance abuse, people requiring ongoing health and nursing care due to chronic impairments and a reduced degree of independence in activities of daily living. (DOH AO No. 2012-0012)</p> <p>See related: Transitional Care Facility.</p>
Cytotoxic	<p>A substance possessing a specific destructive action on certain cells; used particularly in referring to the lysis (disintegration or dissolution) of cells brought about by immune phenomena and to antineoplastic drugs that selectively kill dividing cells.</p>
Decontamination	<p>Reduction of microbiological contamination to a safe level.</p>
Dental Clinic	<p>A section or clinic in a hospital or non-hospital-based facility with standard dental equipment, instruments, and supplies plus all the anesthetic and sterilization apparatus that provides basic and/or expanded outpatient services for oral health education, oral examination, fluoride application, oral prophylaxis, tooth filling, tooth extraction, root canal, minor surgeries. May also offer specialized dentistry services such as orthodontic treatment, cosmetic dentistry, prosthodontic dentistry, and diagnostic dental services. (DOH-HFDB Health Facilities Dictionary)</p> <p>See related: Primary Care Facility.</p>
Diagnostic Facility	<p>A type of health facility that examines the human body or specimens from the human body (except laboratory for drinking water analysis) for the diagnosis, sometimes treatment, of diseases. The test covers the pre-analytical, analytical, and post-analytical phases of examination. (DOH AO No. 2012-0012)</p>
Dialysis Clinic	<p>A health facility where a cleansing process using dialyzing equipment (artificial kidney) and appropriately recognized procedures are performed. (DOH AO No. 2012-0001)</p> <p>See related: Specialized Health Facility.</p>
Disinfection	<p>Reduction or removal of disease-causing microorganisms (pathogens) in order to minimize the potential for disease transmission.</p>
Disposal	<p>Discharge, deposit, placing or release of any HCW into or on any air, land, or water.</p>
Drug Abuse Treatment and Rehabilitation Center	<p>A health facility that provides comprehensive patient drug treatment and rehabilitation services that range within a spectrum of medical and psychological management. This is further classified into: (DOH-HFDB Health Facilities Dictionary)</p> <ul style="list-style-type: none"> a) Non-residential Treatment and Rehabilitation Center / Outpatient Center—a health facility that provides diagnosis, treatment, and management of drug dependents on an outpatient basis. It may be a drop-in/walk-in center, recovery clinic, or any other facility with consultation and counseling as the main services provided; or may be an aftercare service facility. Patients diagnosed with moderate substance use disorder are oftentimes referred to this center. b) Residential Treatment and Rehabilitation Center / Inpatient Center—a health facility that provides comprehensive and rehabilitation services utilizing any of the accepted modalities as described in the Manual of Operations towards the rehabilitation of a person with substance use disorder in an inpatient basis. Patients diagnosed with severe substance use disorder are oftentimes admitted to this center. c) Residential Treatment and Rehabilitation Center with Outpatient

	<p>Service Capability—a health facility that provides both outpatient and inpatient services.</p> <p>See related: Specialized Health Facility.</p>
Drug Testing Facility	<p>A health facility that is capable of testing a specimen to determine the presence of dangerous drugs therein. (DOH-HFDB Health Facilities Dictionary)</p> <p>a) Screening Laboratory—a laboratory capable of drug screening test to eliminate negative specimen from further consideration and to identify the presumptively positive specimen.</p> <p>b) Confirmatory Laboratory—a laboratory that performs qualitative and quantitative examination of a specimen independent from that of a drug screening test.</p> <p>See related: Diagnostic Facility.</p>
General Hospital	<p>A type of hospital that provides services for all kinds of illnesses, diseases, injuries, or deformities. A general hospital shall provide medical and surgical care to the sick and injured, maternity, newborn, and child-care. It shall be equipped with the service capabilities needed to support board-certified/eligible medical specialist and other licensed physicians rendering services in, but not limited to, clinical services (family medicine; pediatrics; internal medicine; obstetrics and gynecology; surgery), emergency services, outpatient services, ancillary and support services such as clinical laboratory, imaging facility, pharmacy. (DOH AO No. 2012-0012)</p> <p>a) Level 1 Hospital—Non-departmentalized hospital that provides clinical care and management on the prevalent diseases in the locality with clinical services that include general medicine, pediatrics, obstetrics and gynecology, surgery and anesthesia. Provides appropriate administrative and ancillary services (clinical laboratory, radiology, pharmacy) and provides nursing care for patients who require intermediate, moderate, and partial category of supervised care for 24 hours or longer.</p> <p>b) Level 2 Hospital—Departmentalized hospital that provides clinical care and management on the prevalent diseases in the locality, as well as particular forms of treatment, surgical procedures, and intensive care. Same clinical services provided in Level 1 Hospital, as well as specialty clinical care. Provides appropriate administrative and ancillary services (clinical laboratory, radiology, pharmacy), gives total nursing and intensive skilled care.</p> <p>c) Level 3 Hospital—Teaching and training hospital that provides clinical care and management on the prevalent diseases in the locality, as well as specialized forms of treatment, surgical procedure, and intensive care. Same clinical services provided in Level 2 Hospital, as well as sub-specialty clinical care. Provides appropriate administrative and ancillary services (clinical laboratory, radiology, pharmacy), nursing care, and continuous and highly specialized critical care.</p> <p>See related: Hospital.</p>
Genotoxic	<p>A substance that can interact directly with genetic material, causing DNA damage that can be assayed. It may refer to carcinogenic, mutagenic, or teratogenic substances.</p>
Half-life	<p>Specific period that a radiation element decays.</p>
Halfway House	<p>A community-based, short-term, housing facility for those in recovery from physical, mental, and emotional disabilities, including those suffering from mild to moderate drug and alcohol dependence, with a structured</p>

	environment and crucial support in reintegrating into society. (DOH-HFDB Health Facilities Dictionary) See related: Transitional Care Facility .
Hazardous Waste	All waste generated by HCF except general waste.
Health Care Facility (HCF) / Health Facility	An institution that has health care as its core service, function, or business. Health care pertains to the maintenance or improvement of the health of individuals or populations through the prevention, diagnosis, treatment, rehabilitation, and chronic management of disease, illness, injury, and other physical and mental ailments or impairments of human beings. (DOH-HFDB Health Facilities Dictionary)
Health Care Workers	All staff in the HCF, i.e., doctors, nurses, administrative staff, paramedical, ancillary workers, institution workers, nursing attendants, dental aides, laboratory aides, janitors, maintenance, radiology aide, social workers, etc.
Health Office	A barangay, municipal, city, province, regional government or private office that does not provide direct health services or with health services not defined as its core service, function, or business. These include administrative and management offices of municipal, city, provincial, and regional health units. Examples: Municipal Health Office, City Health Office, Provincial Health Office, Regional Health Office, research offices, etc. (DOH-HFDB Health Facilities Dictionary)
Highly Infectious Waste	Cultures and stocks of highly infectious agents; waste from autopsies, animal bodies, and other waste items that have been inoculated, infected or in contact with such agents; wastes contaminated with organisms belonging to Biosafety Levels 3 and 4; wastes contaminated with pathogens mentioned in DOH AO 2010-0033.
Human Immunodeficiency Virus (HIV) Testing Center	A health facility credited by the Health Facilities and Services Regulatory Bureau (HFSRB), capable of performing HIV Testing by medical technologists that have undergone the training on HIV Testing Proficiency. (DOH AO No. 2014-0005) See related: Diagnostic Facility .
Hospice	A health facility that provides hospice care defined as a component of palliative care of a chronically ill, terminally ill, or seriously ill patient's pain and symptoms, otherwise known as end-of-life care that consists of medical, psychological, spiritual, and practical support or patients unable to perform self-care and with declining conditions despite definitive treatment and other disease-modifying interventions. (IRR of RA 11215) See related: Transitional Care Facility .
Hospital	A place devoted primarily to the maintenance and operation of facilities for the diagnosis, treatment, and care of individuals suffering from illness, disease, injury, deformity, or in need of obstetrical or other medical and nursing care. The term 'hospital' shall also be construed as any institution, building, or place where there are installed beds, or cribs, or bassinets for 24-hour use or longer by patients in the treatment of diseases, diseased-conditions, injuries, deformities, or abnormal physical and mental states, maternity cases, and all institutions such as those for convalescence, sanatoria or sanatoria care, infirmaries, nurseries, dispensaries, and such other names by which they may designated. (RA 4226)
Household Waste	Wastes produced from activities within the household.
Human Stem Cell Clinic (Cellular Therapy Facility)	A facility that may act as an entity providing the service of cellular therapy product collection and a location where cellular therapy product processing activities are performed in support of its clinical program. The facility may also serve as the storage area for cellular therapy product for

	<p>future processing, distribution, or administration. (DOH AO No. 2013-0012)</p> <p>See related: Specialized Health Facility.</p>
Infectious Waste	<p>Waste that contains pathogens like bacteria, viruses, parasites or fungi in sufficient concentration or quantity to cause disease in susceptible hosts.</p>
Infirmary	<p>A health facility that provides emergency treatment and care to the sick and injured, as well as clinical care and management to mothers and newborn babies. It provides basic, non-complex inpatient, diagnostic, and treatment services usually by general practitioners. The need for infirmaries is decided according to the local context. (RA 4226; DOH AO No. 2012-0012)</p> <p>See related: Transitional Care Facility.</p>
Leachate	<p>Liquid produced when HCW undergoes decomposition, and when water percolates through solid waste undergoing decomposition. It is a contaminated liquid that contains dissolved and suspended materials.</p>
Medical Facilities for Overseas Workers and Seafarers	<p>A health facility that conducts Pre-Employment Medical Examination (PEME), which refers to a complete medical examination during screening to determine physical and mental fitness to work for overseas workers and seafarers for inter-island/overseas employment. (DOH AO No. 101-2004)</p> <p>See related: Primary Care Facility.</p>
Medical Outpatient Clinic	<p>A health facility that provides ambulatory general or specialized outpatient care to patients with injuries or infirmity requiring the range of non-urgent to immediate care, commonly addressing minor and non-life-threatening illness and injuries. Examples: Family Planning Clinic, HIV Clinic, Social Hygiene Clinic, School Clinic, Office Clinic, etc. (DOH-HFDB Health Facilities Dictionary)</p> <p>See related: Primary Care Facility.</p>
Mental Health Facility	<p>Any establishment or unit of an establishment, which has as its primary function the provision of mental health services. (RA 11036)</p> <p>See related: Transitional Care Facility.</p>
National Reference Laboratory	<p>The highest level of laboratory in the country, mandated to provide laboratory confirmatory services, provide training, perform surveillance, do outbreak response, provide External Quality Assurance, perform kit evaluation, and do research. NRL may have designated Sub-National Laboratories (SNL).</p> <p>See related: Diagnostic Facility.</p>
Newborn Hearing Screening Reference Center	<p>The central facility at the National Institutes of Health (NIH) that defines testing and follow-up protocols, maintains an external laboratory proficiency testing program, oversees the national testing database and case registries, assists in training activities in all aspects of the program, and oversees content of educational materials. (RA 9709)</p> <p>See related: Diagnostic Facility.</p>
Newborn Screening Reference Center (NSRC)	<p>The central facility at the National Institutes of Health (NIH) that defines testing and follow-up protocols, maintains an external laboratory proficiency testing program, oversees the national testing database and case registries, assists in training activities in all aspects of the Newborn Screening (NBS) program, oversees content of educational materials, recommends establishment of Newborn Screening Centers (NSCs) and acts as the Secretariat of the Advisory Committee on Newborn Screening. (IRR of RA 9288)</p>

	See related: Diagnostic Facility .
Non-Hazardous Waste	Waste that has not been in contact with infectious agents, hazardous chemicals, or radioactive substances, and that does not pose a sharps hazard.
Nuclear Medicine Facility	A health facility, presently regulated by Philippine Nuclear Research Institute (PNRI), embracing all applications of radioactive materials in diagnosis, treatment, or in medical research, with the exception of the uses of sealed radiation sources in radiotherapy. (DOH AO No. 2012-0012) See related: Diagnostic Facility .
Nursing Home	A residential facility providing a high level of long-term custodial, personal, or nursing care for persons such as the aged or the chronically ill. The facility may also provide palliative and/or hospice care at the end of life. (DOH-HFDB Health Facilities Dictionary) See related: Transitional Care Facility .
Off-site Collection	Collection and transfer of segregated HCW from the HCF-Central Storage Area (CSA) to DENR Accredited Transporter/Municipal Waste Collector/Supplier.
Off-site Transport	Transport of segregated HCW from HCF to Treatment Facilities or to Final Disposal on-site collection area.
Office Clinic	A medical outpatient clinic inside a professional work or employment environment that provides primary care services including treatment of minor ailments, immediate management of emergency cases, health education, health promotion, and referral to an appropriate facility. (DOH-HFDB Health Facilities Dictionary) See related: Primary Care Facility .
On-site Collection	Collection of segregated HCW from the point of generation to designated color-coded bins.
On-site Transport	Transport of collected segregated HCW from the designated color-coded bins to CSA.
Pharmaceutical Outlet	Refer to entities licensed by appropriate government agencies, and which are involved in compounding and/or dispensing and selling of pharmaceutical products directly to patient or end-users. (RA 10918) See related: Specialized Health Facility .
Physical Therapy and Rehabilitation Facility	A health facility concerned with the maximal restoration or development of physical, physical, psychological, social, occupational, and vocational functions in persons whose abilities have been limited by disease, trauma, congenital disorders, or pain to enable people to achieve their maximum functional abilities. It involves the diagnosis, evaluation, and management of people of all ages physical and/or cognitive impairment and disability (DOH AO No. 2012-0012) See related: Specialized Health Facility .
Primary Care Facility	A type of health facility that provides population- and individual-based health services that accessible, continuous, comprehensive, and coordinated care that is accessible at the time of need, including a range of services for all presenting conditions. It also serves as the initial point of contact for individual-based services, through its ability to navigate and coordinate referrals to other health care providers in the health care delivery system, when necessary. (DOH-HFDB Health Facilities Dictionary)
Pyrolysis	Thermal decomposition of substance and materials in the absence of supplied molecular oxygen in the destruction chamber in which the said

	material is converted into gaseous, liquid, or solid form.
Quarantine Clinic	A designated health facility for referral of suspect/s or probable case/s of public health emergency of international concern where people who have been exposed to an illness, usually an infection, but are not ill or have not yet shown any sign of the illness are restricted to. (IRR RA 9271) See related: Specialized Health Facility .
Radioactive Waste	Material that contains, or is contaminated with, radionuclides at concentrations or activities greater than clearance levels.
Radiologic Facility	A health facility concerned with the use of imaging techniques in the study, diagnosis, and X-ray guided treatment of disease. This includes the use of x-rays in in general radiography and fluoroscopy, interventional radiology, lithotripsy, computed tomography, mammography, bone densitometry, and tumor localization and simulation. (DOH-HFDB Health Facilities Dictionary) See related: Diagnostic Facility .
Re-use	Process of recovering materials intended for the same or different purpose without the alteration of physical and chemical characteristics.
Recovery Clinic	A non-residential treatment facility where specialized consultations, evaluations, and treatment may be provided for those recovering from drug use. (DOH-HFDB Health Facilities Dictionary) See related: Specialized Health Facility .
Recyclable	Any waste material retrieved from the waste stream and free from contamination that can still be converted into suitable and beneficial use or for other purposes, including, but not limited to cardboard, glass, office paper, drink cans, newspapers, magazines and polyethylene or polypropylene plastics (PE and PET).
Recycling	Processing of used materials (waste) into new products to prevent waste of potentially useful materials, reduce the consumption of fresh raw materials, reduce energy usage, reduce air pollution and water pollution (from land filling) by reducing the need for 'conventional' waste disposal, and lower greenhouse gas emissions as compared to virgin production.
Rural Health Unit (RHU) / Urban Health Unit (UHU)	A government primary health facility that serves as first contact primary care services in the municipality or city delivering health promotion, disease prevention, health maintenance, counseling, patient education, diagnosis, management, and treatment of acute and chronic illnesses and referrals. It ensures a follow-through course of treatment of a person as a whole and provides both population- and individual-based health services. It provides leadership in patient navigation and coordination in a network and follows the standards set by the DOH. The RHU/UHU is equivalent to the Municipal or City Health Center of the Local Government Code of 1991. The term 'health center' is sometimes used by communities to refer to these facilities. (DOH-HFDB Health Facilities Dictionary) See related: Primary Care Facility .
Sanitarium	An institution established to make available hospital services specifically for Hansenites (Hansen's Disease). The sanitarium serves as the referral center for the management of complications, patient and family counseling, and community education for leprosy and also for the integration of its Multi-Drug Therapy (MDT) treatment. (DOH AO No. 2005-2013) See related: Transitional Care Facility .
Sanitary Landfill Facility (SLF)	An engineered method designed to keep the waste isolated from the environment.

School Clinic	A medical outpatient clinic inside school, college, or university premises that provides primary care services including, but not limited to, oral care, health education, health promotion, treatment of minor ailments, immediate management of emergency cases, and referral to an appropriate facility, following the standards set by the DOH. (DOH-HFDB Health Facilities Dictionary) See related: Primary Care Facility .
Segregation	Separating the waste generated by the HCF according to the specific treatment and disposal requirements.
Sludge	Accumulated solids that separate from liquids such as water or wastewater during processing, or deposits on the bottom of streams or other bodies of water.
Specialized Health Facility	A type of health facility that provides highly specialized care addressing particular conditions and/or providing specific procedures and management of cases requiring specialized training and/or equipment. Specialized health facilities within hospitals are recognized as a service/unit and not as a separate stand-alone facility. (DOH-HFDB Health Facilities Dictionary)
Specialty Hospital	A hospital that specializes in a particular disease or condition or in one type of patient. A specialized hospital may be devoted to any of the following: (DOH-HFDB Health Facilities Dictionary) a) Treatment of a particular type of illness or for a particular condition requiring a range of treatment. Examples: Philippine Orthopedic Center, National Center for Mental Health, San Lazaro Hospital b) Treatment of patients suffering from diseases of a particular organ or groups of organs. Examples: Lung Center of the Philippines, Philippine Heart Center, National Kidney and Transplant Institute c) Treatment of patients belonging to a particular group such as children, women, elderly, and others. Examples: Philippine Children's Medical Center, National Children's Hospital, Dr. Jose Fabella Memorial Hospital See related: Hospital .
Sterilization	Destruction of all microbial life
Storage	Area or place where HCW is temporarily stored after generation and prior to collection for ultimate recovery or disposal.
Traditional and Complementary Medicine Clinic	A health facility that provides a broad set of health care practices that are not integrated into dominated the dominant health care system. Examples are, but not limited to, the following services: acupuncture; chiropractic; naturopathy, etc. (PITAHC Order No. 2018-109)
Transitional Care Facility	A type of health facility that oversees the continuity of care during the course of chronic or acute illness. The transitional care facilities also encompass both the sending and receiving aspects of transfers including, but not limited to, logistical arrangements, patient and family health education, and coordination among health professionals involved in the transition. (DOH-HFDB Health Facilities Dictionary)
Waste Disposal	Refers to the intentional burial, deposit, discharge, dumping, placing, or release of any waste material into or on air, land, or water.
Waste Generator	Any person, organization, or facility engaged in activities that generate waste.
Waste Management	All the activities, administrative and operational, involved in the handling, treatment, storage, collection, transportation, and disposal of wastes.

Waste Treatment	Any method, technique, or process for altering the biological, chemical, or physical characteristics of waste to reduce the hazards it presents and facilitate or reduce the costs of disposal. The basic treatment objectives include volume reduction, disinfection, neutralization, or other change of composition to reduce hazards including removal of radionuclides from radioactive wastes.
-----------------	---

ANNEX A: Process Flow Diagrams

Annex A 1: Health Care Waste Management per Type of Waste

Annex A 2: Process Flow for Waste Minimization for Urban Area With Access to a Legally Approved Modern Waste Treatment Facility

Annex A 3: Process Flow for Waste Minimization for Urban Area Without Access to a Legally Approved Modern Waste Treatment Facility

Annex A 4: Process Flow for Waste Minimization for Rural Area Without Access to a Legally Approved Modern Waste Treatment or Disposal Facility

Annex A 5: Process Flow for Needle-Syringes Waste Management – Immunization at PHC

Annex A 6: Process Flow Needle-Syringes Waste Management - Outreach Immunization Activities

Annex A 7: Incineration Process with Flue Gas

Annex A 8: Wastewater Process Flow

Annex A 9: Sample Flowchart on the Management of Occupational Accident/Incident for Tertiary Hospitals

Annex A 1: Health Care Waste Management per Type of Waste

Sharps Waste

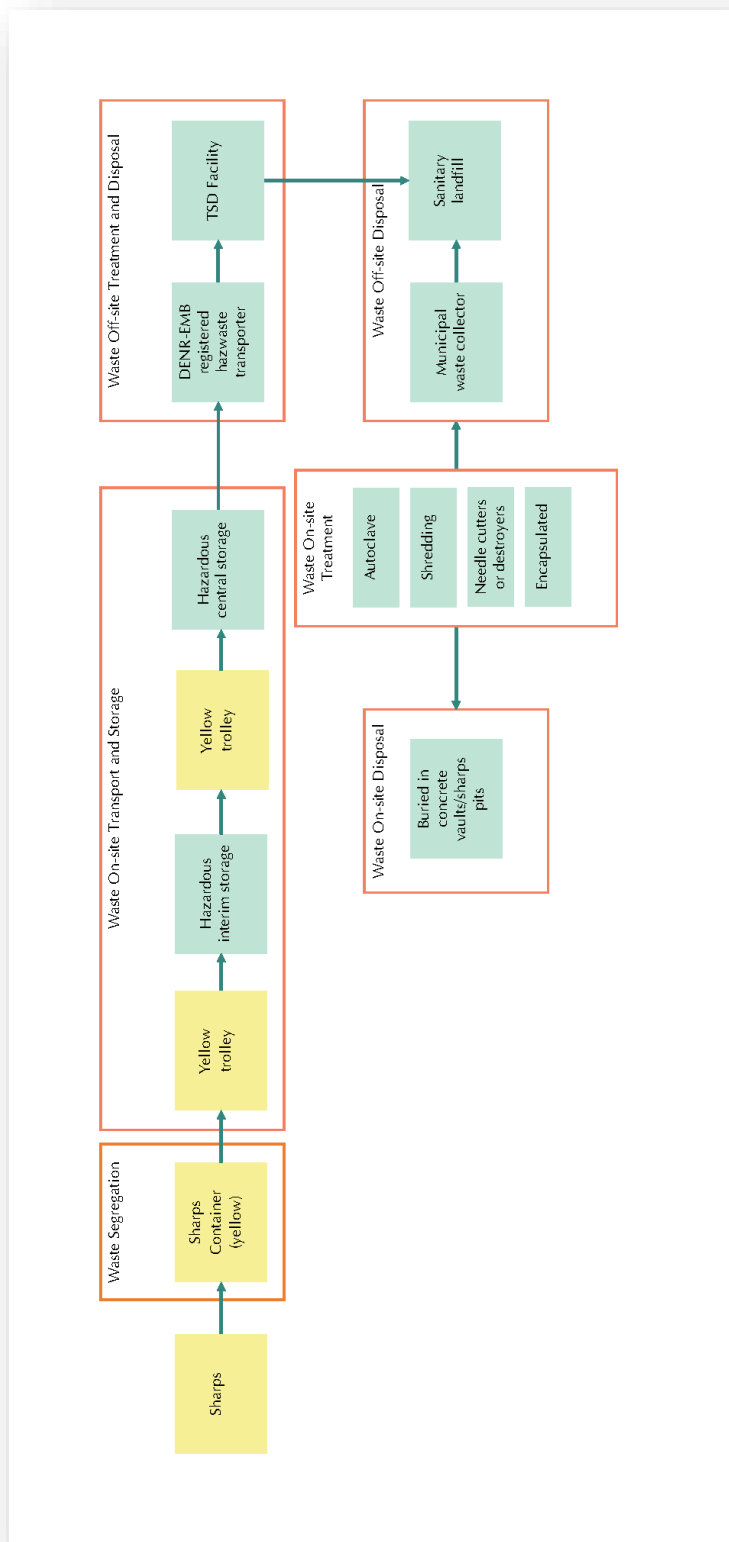

Chemical Waste

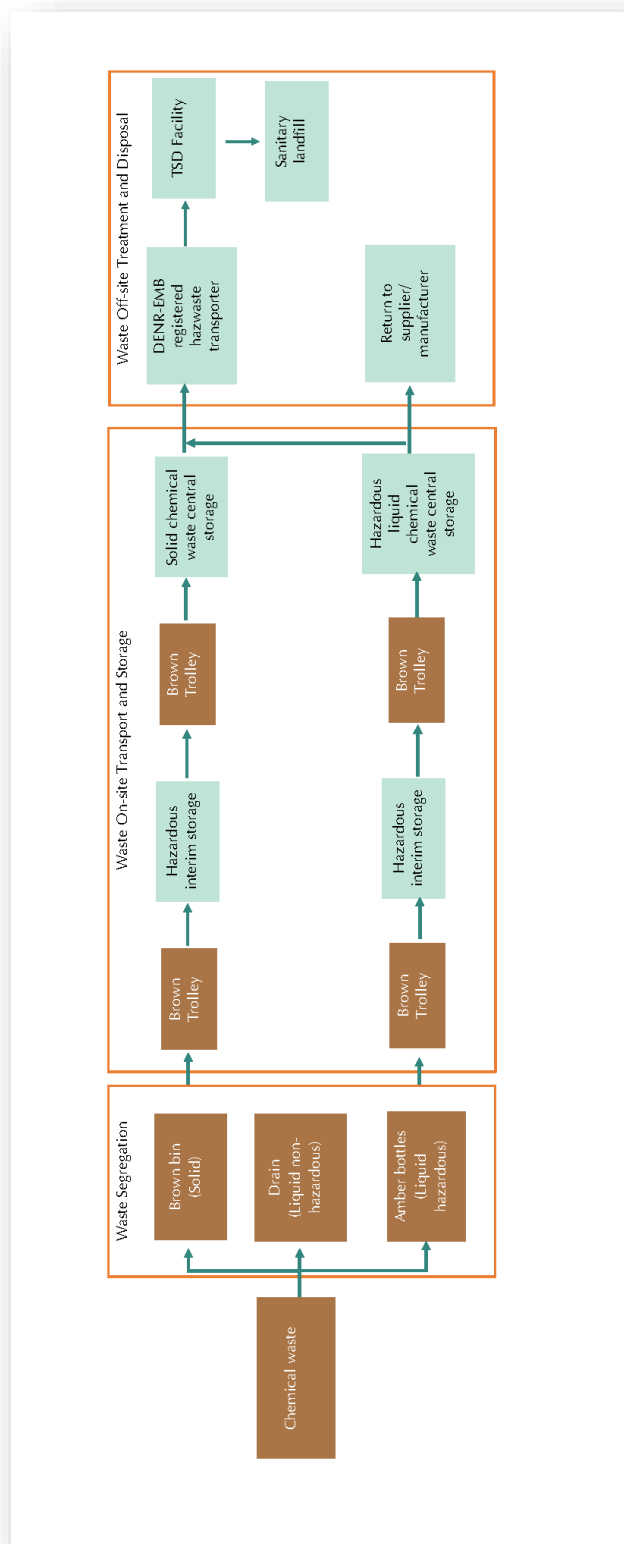

Pharmaceutical Waste

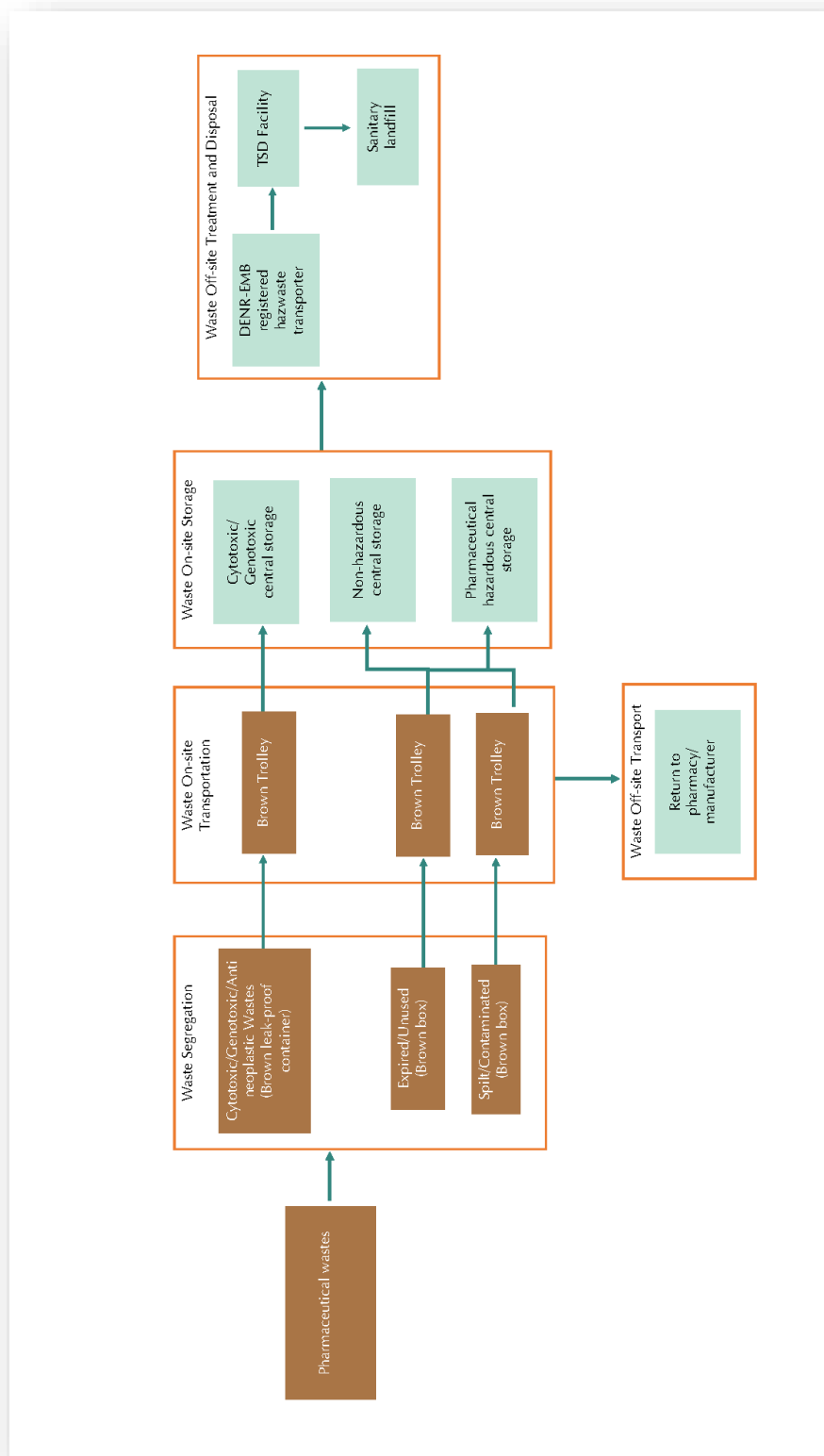

Radioactive Waste

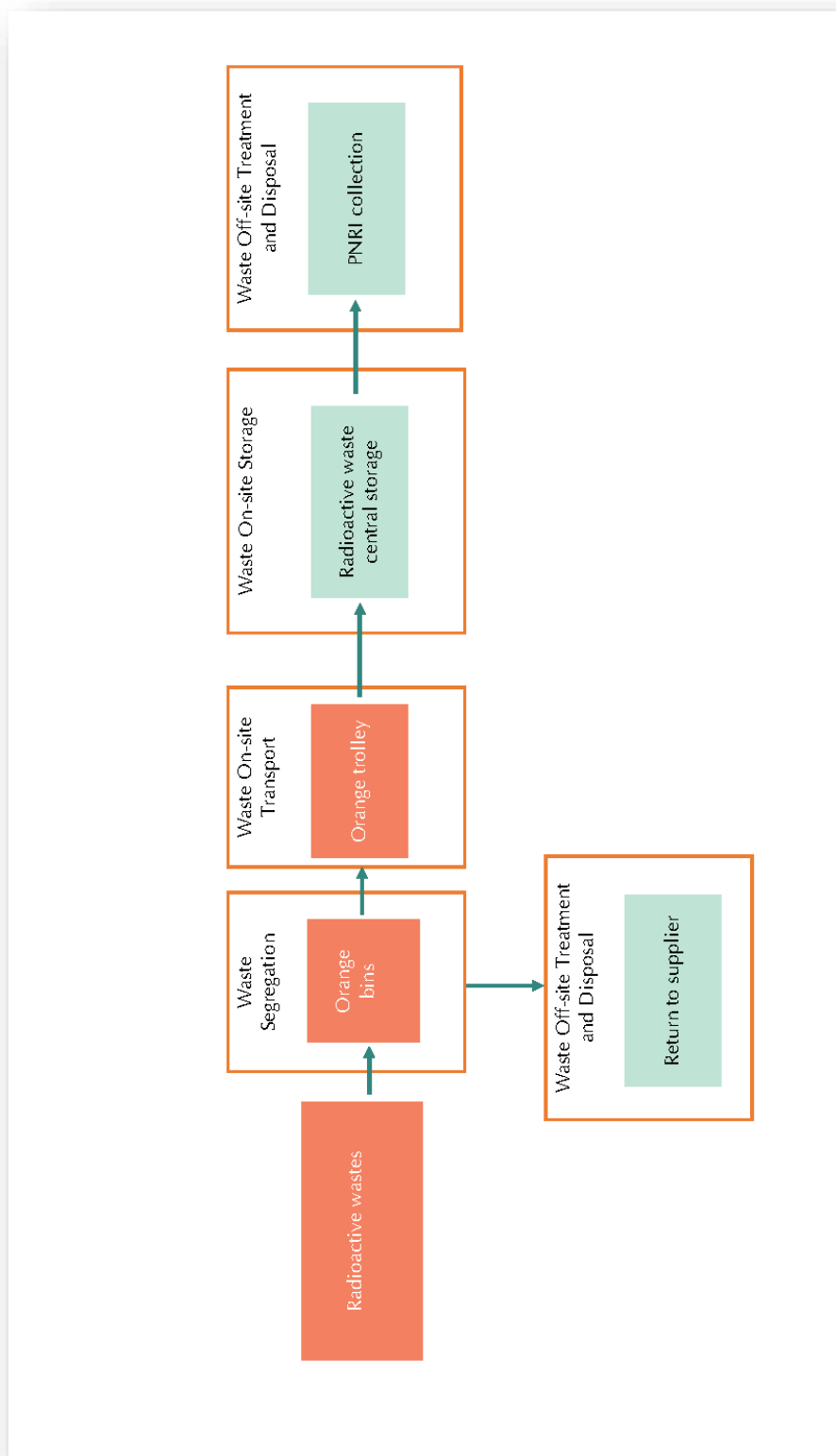

Pathological Waste

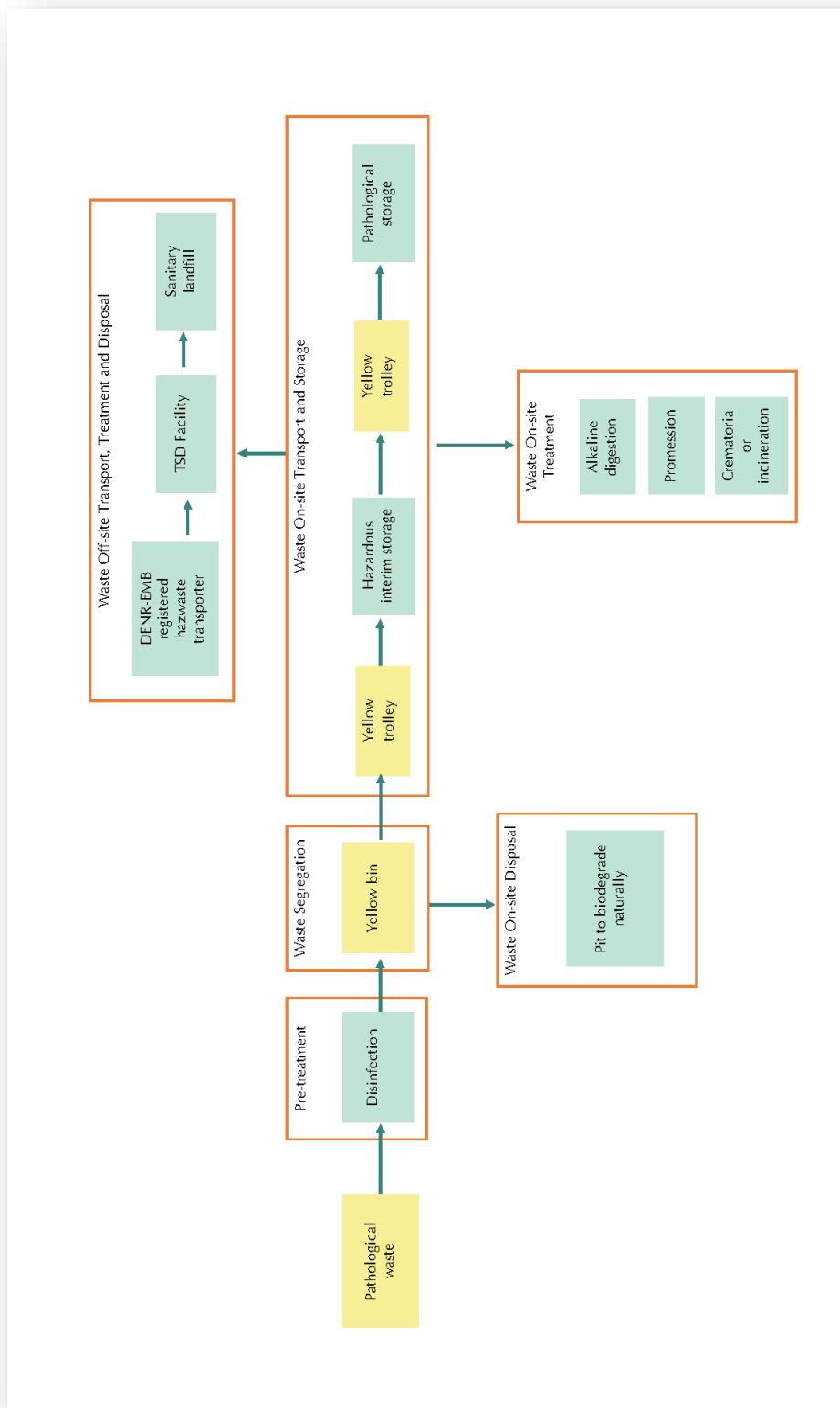

Anatomical Waste

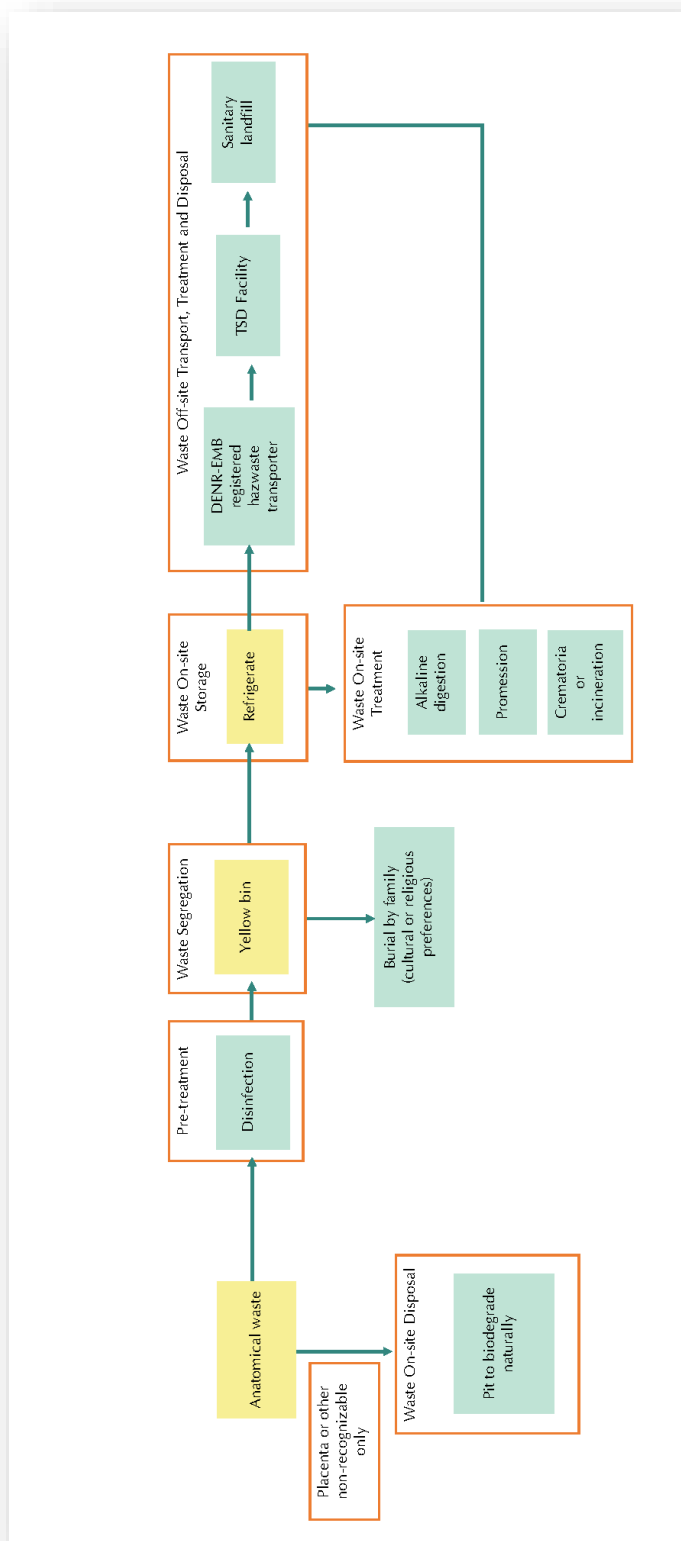

Highly Infectious Waste

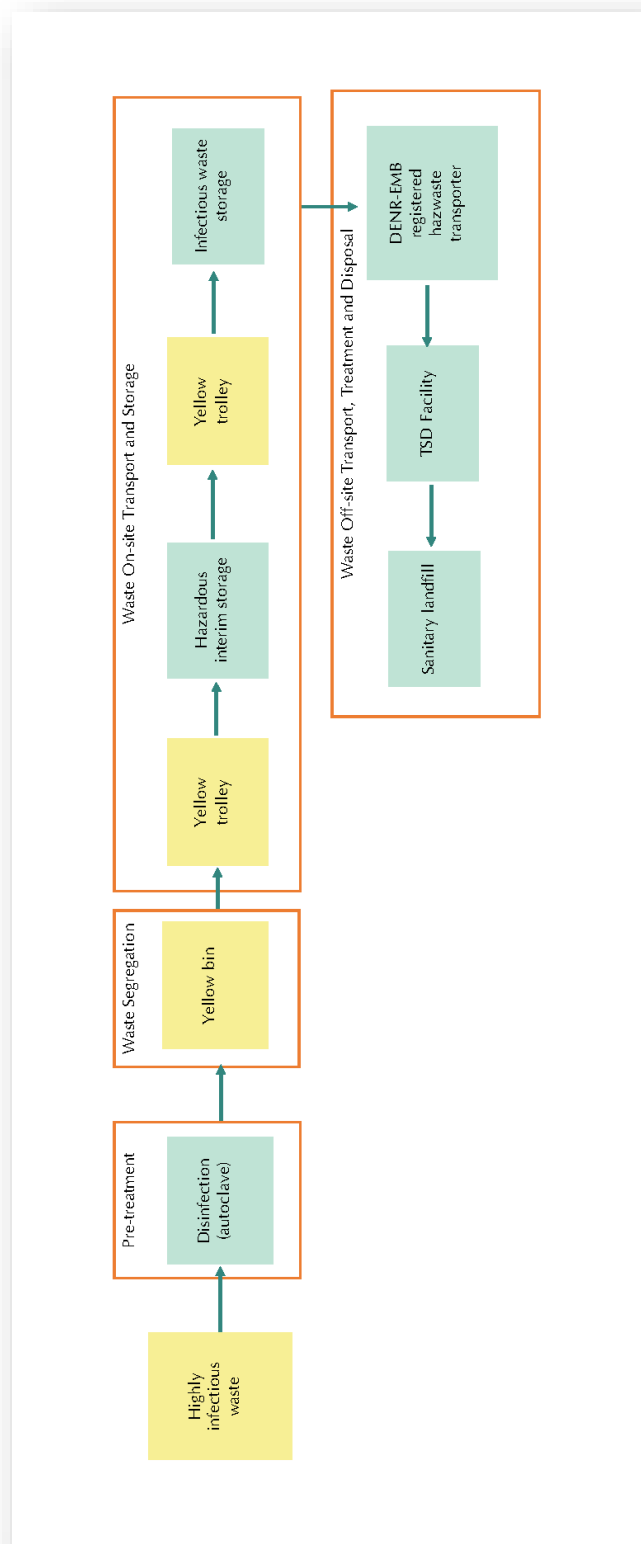

General Waste (Non-hazardous)

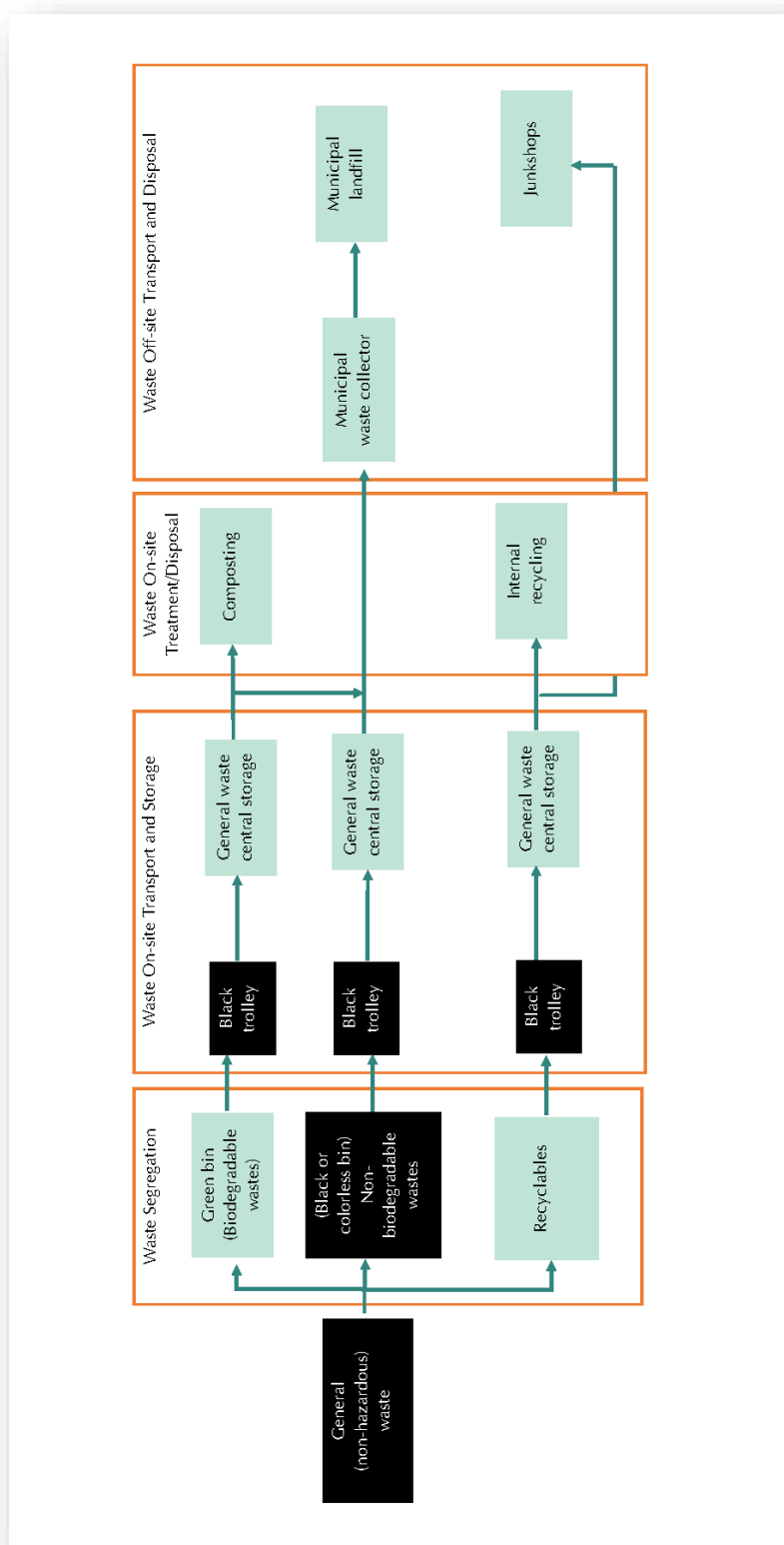

Annex A 2: Process Flow for Waste Minimization for Urban Area With Access to a Legally Approved Modern Waste Treatment Facility

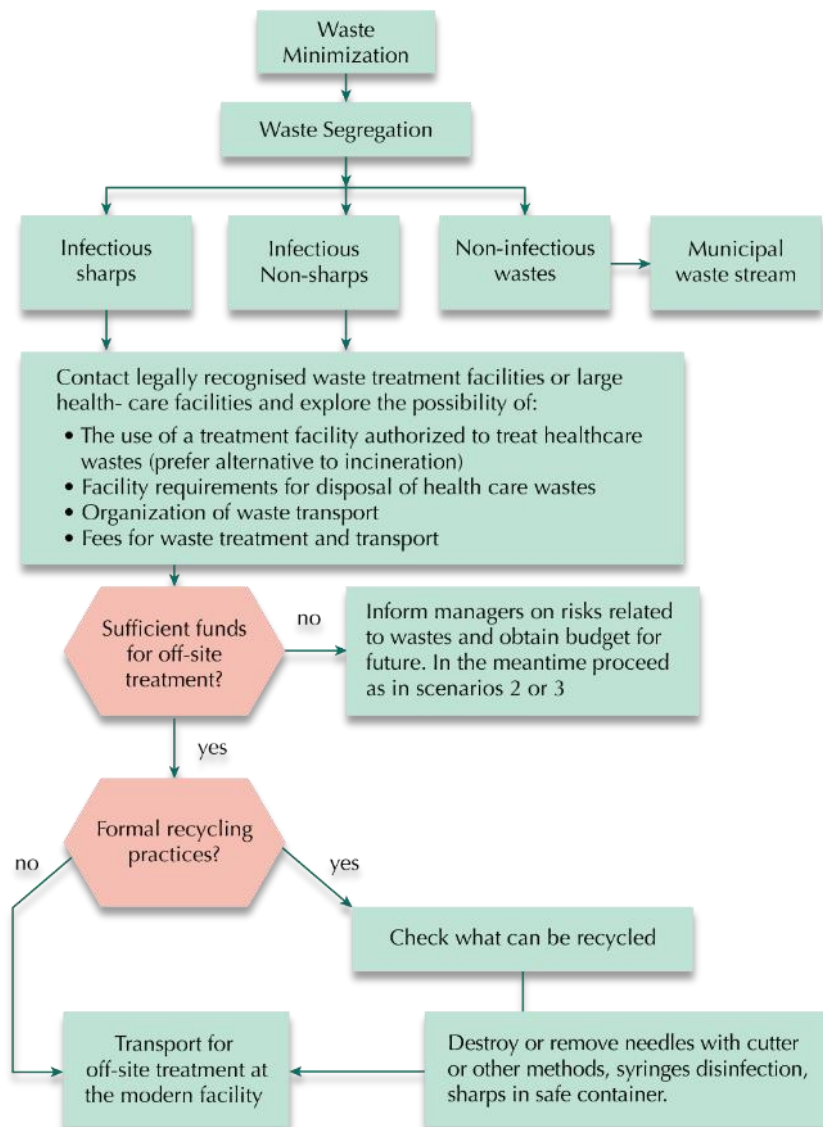

Source: Management of solid health-care waste at primary health-care centres (WHO 2005)

Annex A 3: Process Flow for Waste Minimization for Urban Area Without Access to a Legally Approved Modern Waste Treatment Facility

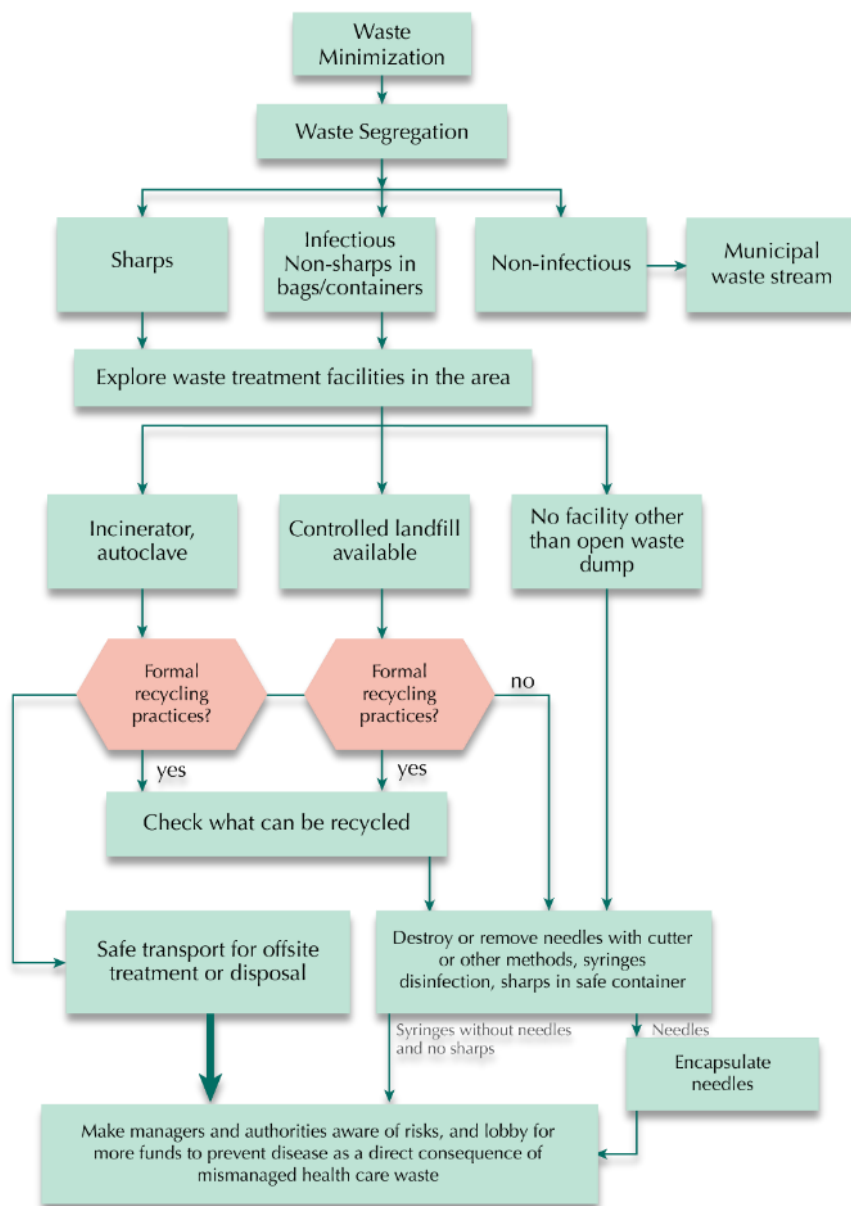

Source: Management of solid health-care waste at primary health-care centres (WHO 2005)

Annex A 4: Process Flow for Waste Minimization for Rural Area Without Access to a Legally Approved Modern Waste Treatment or Disposal Facility

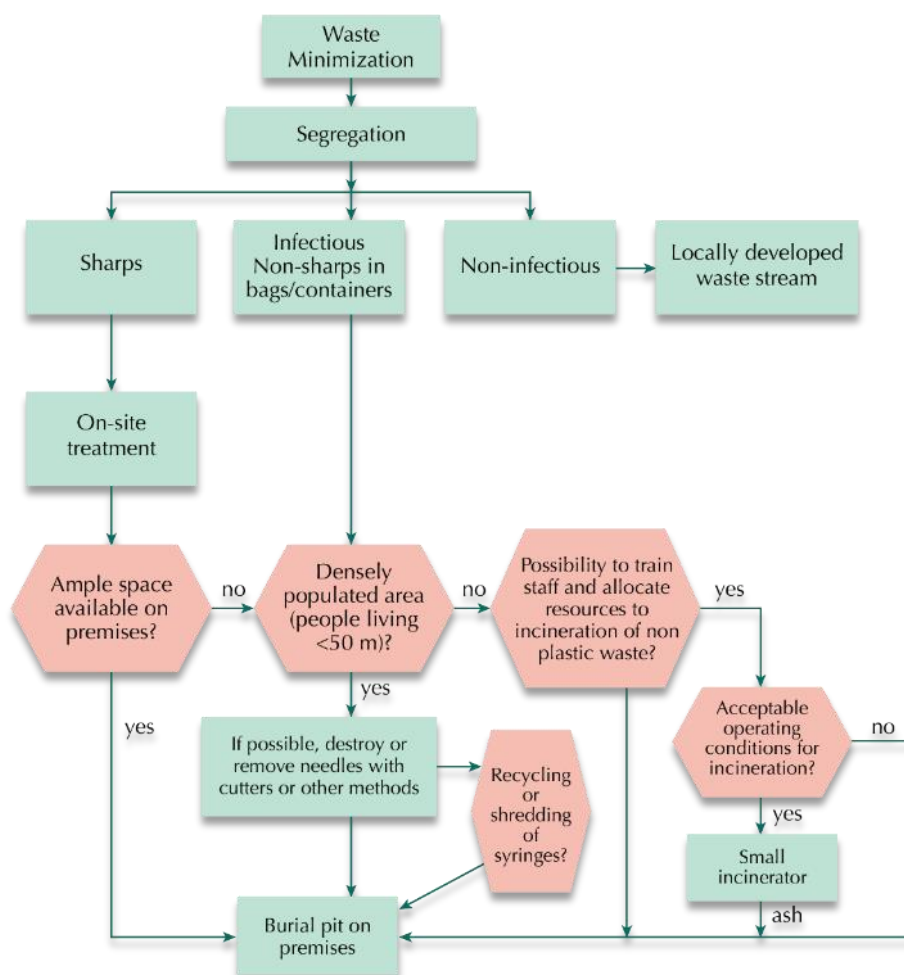

Source: Management of solid health-care waste at primary health-care centres (WHO 2005)

Annex A 5: Process Flow for Needle-Syringes Waste Management – Immunization at PHC

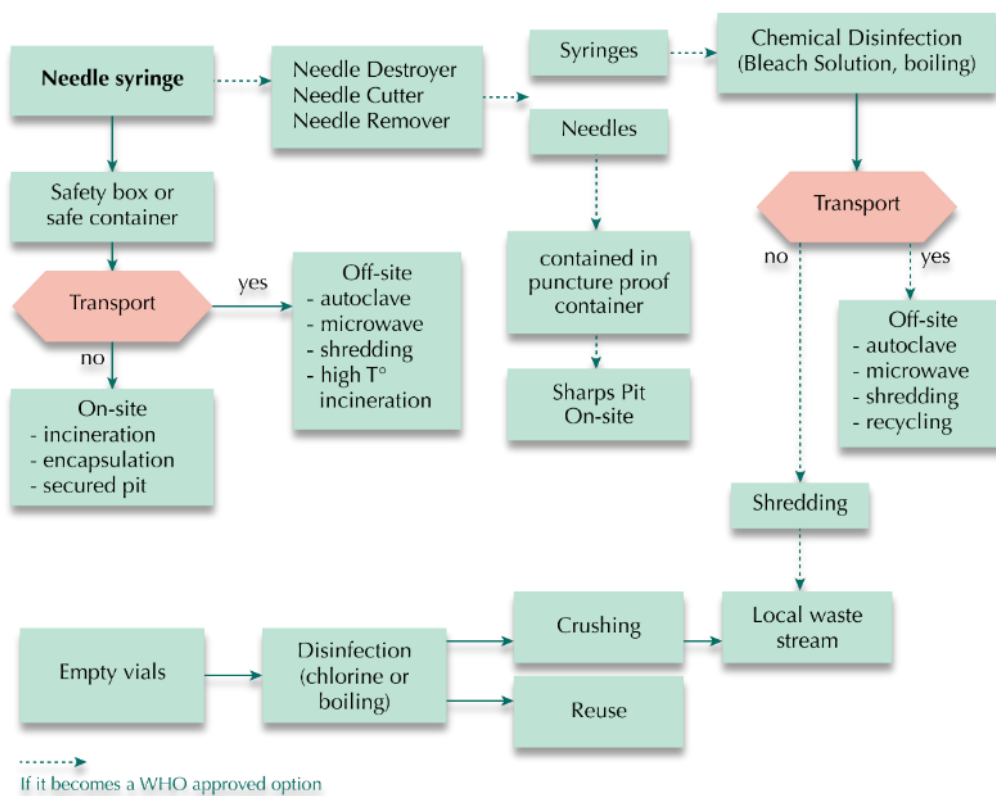

Source: Management of solid health-care waste at primary health-care centres (WHO 2005)

Annex A 6: Process Flow Needle-Syringes Waste Management - Outreach Immunization Activities

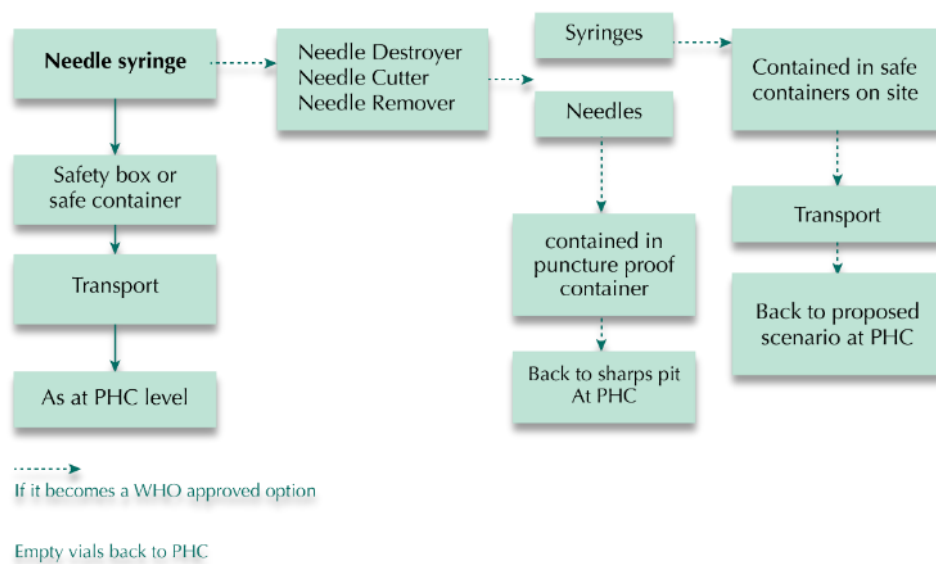

Source: Management of solid health-care waste at primary health-care centres (WHO 2005)

Annex A 7: Incineration Process with Flue Gas

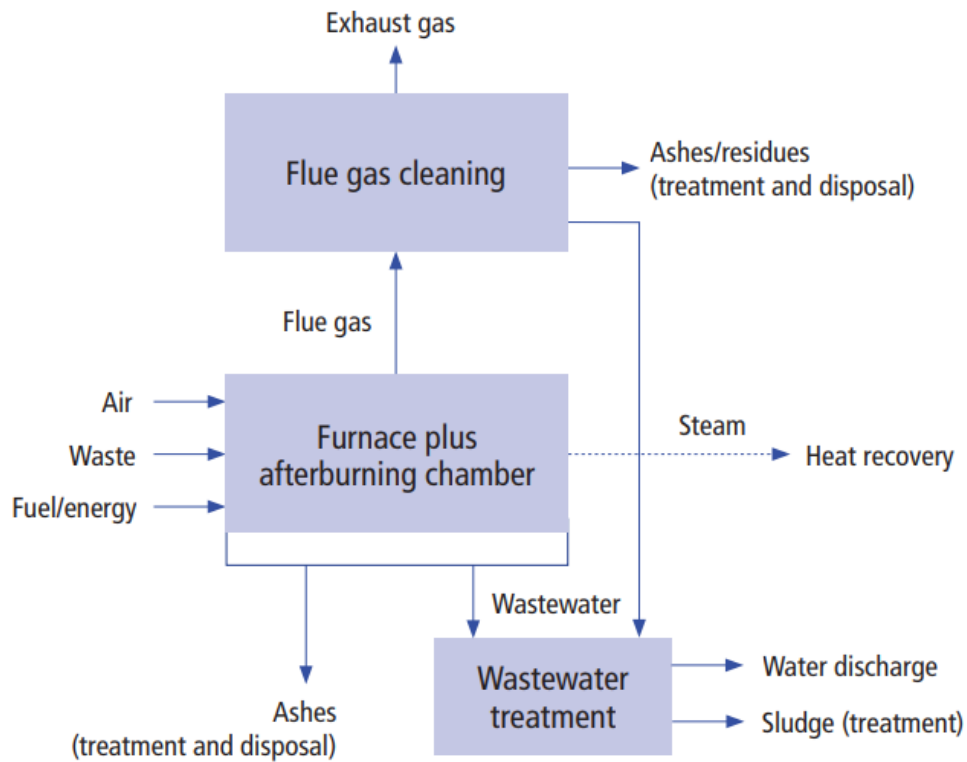

Source: Safe Management of Wastes from Health-Care Activities, 2nd Edition (WHO, 2014)

Annex A 8: Wastewater Process Flow

Flow of wastewater from HCF departments to WWTP

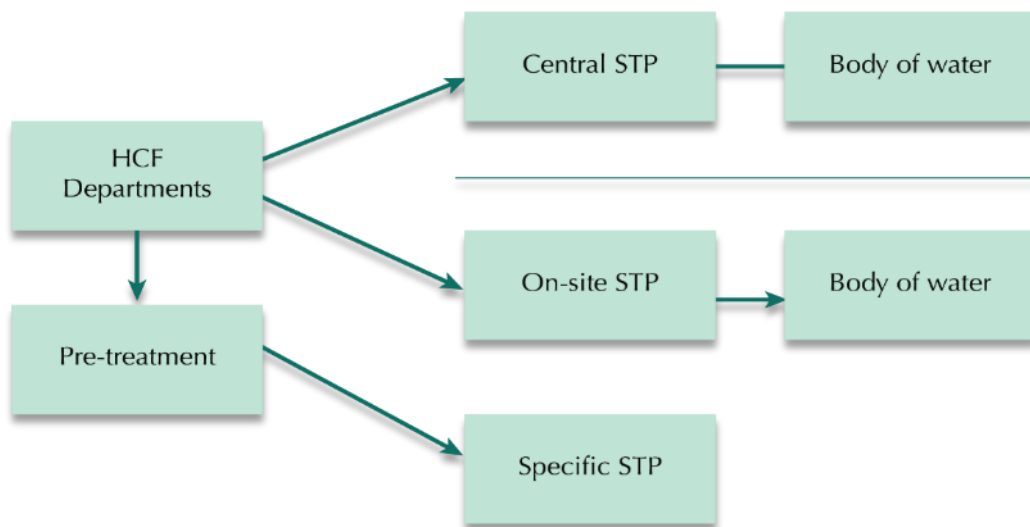

Flow of wastewater within the WWTP

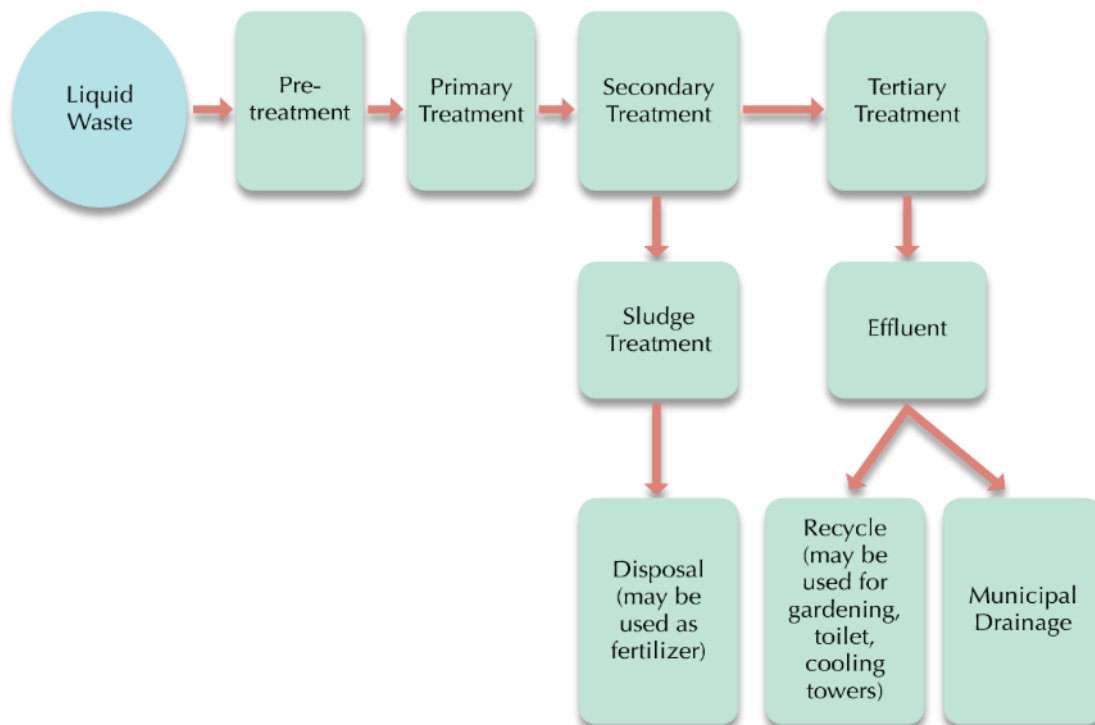

Source: Health Care Waste Management Manual, 3rd Edition (DOH, 2011)

Annex A 9: Sample Flowchart on the Management of Occupational Accident/Incident for Tertiary Hospitals

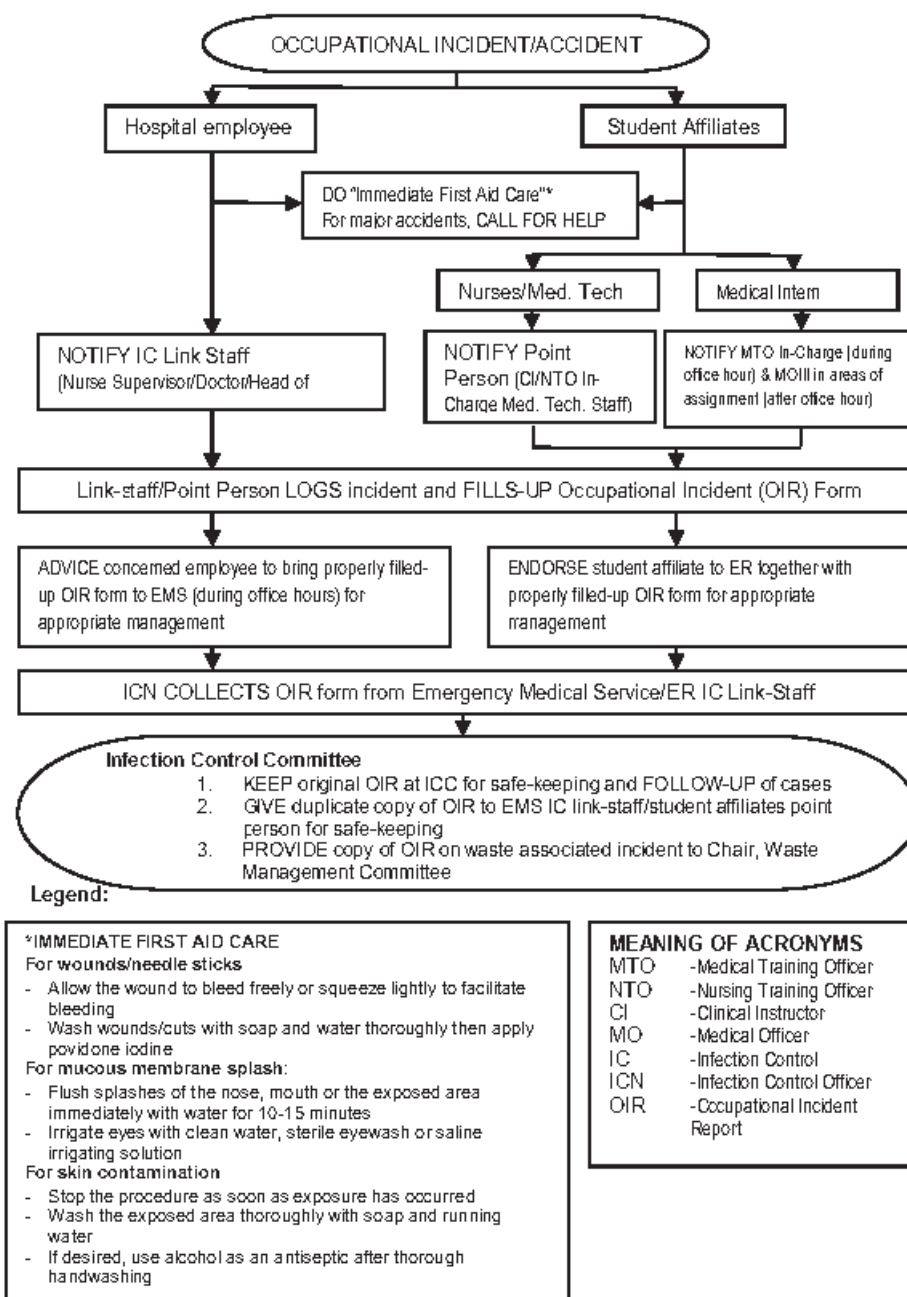

Source: Health Care Waste Management Manual, 3rd Edition (DOH, 2011)

ANNEX B: Requirements and Guides

Annex B 1: Duties and Functions of HCWM Committee Members

Annex B 2: Requirements for Consignment Notes

Annex B 3: Requirements of Off-site Transport Vehicles

Annex B 4: Guide Questions for Selection of Treatment Technology

Annex B 5: Advantages and Disadvantages of Different Treatment Technologies

Annex B 6: Characteristics of the Main Disinfectant Groups

Annex B 7: Advantages and Disadvantages of Different Types of Wastewater Treatment Plant

Annex B 8: Factors to Consider for Establishment of On-Site WWTP

Annex B 9: Suggested Training Package for HCWM Target Group

Annex B 1: Duties and Functions of HCWM Committee Members

CORE TEAM

- A. Waste Management Officer (WMO) – designated as Co-Chair of the HCWM Committee will be responsible for the day to day operation and monitoring of the waste management system in the hospital. The WMO is directly responsible to the Head/Administrator of the HCF. He or she shall establish linkage with the Infection Control Officer, the Chief Pharmacist and the Radiation Officer in order to become familiar with the correct procedures for handling and disposing of pathological, pharmaceutical, chemical and radioactive waste. The duties and responsibilities of the WMO shall include the following:
- Ensure that the internal regular collection of waste observe the proper waste segregation, collection and transport policies and guidelines;
 - Observe and direct the provision of continuous availability of waste bins, plastic liners, personal protective equipment and collection bins/carts and direct supervision of collection crews;
 - Check and direct correct use of central storage facility, which shall be kept locked but accessible to authorized staff at all times;
 - Coordinate and monitor waste treatment, disposal operations, waste transport for both on-site and off-site;
 - Coordinate with the Senior Nursing Officer and Department Heads to ensure that nursing staff and medical assistants as well as doctors and other qualified clinical staff are aware of their responsibilities for segregation and storage of waste; and
 - Ensure that written emergency procedures are available and that personnel are aware of the action to be taken in the event of an emergency. Investigate and review reported incidents concerning the handling of HCW.
- B. Designated Pollution Control Officer (PCO) – shall be responsible for the HCF compliance to the requirements mandated by EMB-DENR and other regulatory agencies. He/she shall be responsible for the following duties and responsibilities:
- Attend to requirements of the HCF prior to the construction or installation of pollution control facilities including the application and securing of necessary pollution permits and renewal;
 - Monitor activities pertaining to the installation or construction of pollution source and control facilities with the end in view of ensuring their compliance with air, noise and water quality standards; the PCO and the head of the HCF shall be held responsible for any violations of PD 984 and its IRR committed by the establishment where the officer is employed;
 - Supervise the proper operation and maintenance of pollution control facilities of the establishment or agency;
 - Report within reasonable time to the EMB-DENR the breakdown of any pollution control facility and the estimated and actual date of completion/repair and operation;
 - Promptly submit validated/certified as correct by the HCF Administrator periodic reports as required by the EMB-DENR;
 - Act as liaison officer and maintain linkage with the DOH, DENR, EMB and designated PCO of other agencies including the local government unit;
 - Keep himself abreast with the requirements of DENR-EMB and the latest available technology on the prevention, control and abatement of pollution; and
 - Attend the meetings for PCO's which may from time to time be called by the monitoring agency.
- C. Designated / Appointed Infection Control Officer (ICO) / Safety Officer (SO) shall be responsible for the following duties and responsibilities:
- Maintain linkage with the WMO on a continuous basis and provide advice concerning the control of infection and the standards of the waste disposal system.
 - Identify training requirements according to staff grade and occupation;
 - Organize and supervise staff training courses on safe waste management;
 - Liaise with the department heads and Senior Nursing Officer regarding the training of their staff;

- Handle the overall responsibility for chemical disinfection, sound management of chemical stores and chemical waste minimization.
 - Ensure that all chemical used in the HCF has a Material Safety Data Sheet (MSDS).
- D. Finance / Budget Officer and Supply Officer -shall be responsible in assuring the provision of continuous logistics, maintaining and sustaining the programs and activities of the HCWM Committee and including them in the annual procurement plan:
- Liaise with the WMO to ensure a continuous supply of the items required for waste management (plastic liners and bins of the right specifications, spare parts for the on-site waste treatment equipment, etc.). These items shall be ordered within a reasonable time to ensure that these are readily available at the HCF at all times. However, excessive accumulation of these items should be avoided.
 - Investigate the possibility of purchasing environmental-friendly products (e.g. PVC-free plastic items) by adopting the principles of Green Procurement Policy.

HCWM COMMITTEE MEMBERS

All HCF management and support staff play a vital part in the success of the program. Equally important are the specific roles and contribution of the following specific key personnel in any HCF:

- A. Division Heads of the Medical, Nursing and Administrative Services shall:
- Ensure strict compliance of their respective staff with the policies and guidelines being implemented by the HCWM Committee;
 - Disseminate policies and guidelines down the line including all the support staff in the HCF;
 - Conduct regular orientation and reorientation among their HCF workers;
 - Maintain linkage with designated WMO
- B. Department Heads are responsible within their respective areas of concern to ensure that all members of their department are aware of the hospital waste management plan as to segregation and storage procedures and that strict compliance is observed. They shall also:
- Ensure that all doctors, nurses, clinical and non-clinical professional staff in their departments are aware of the segregation and storage procedures and that all personnel comply with the highest standards in HCWM;
 - Liaise with the WMO to monitor working practices against failures or mistakes;
 - Ensure that key staff members in their department are given training in waste segregation and disposal procedures; and
 - Encourage medical and nursing staff to be vigilant to ensure that hospital attendants and ancillary staff follow correct procedures at all times.
- C. The Senior Nursing Officer is responsible for the training of the nursing staff, medical assistants, hospital attendants and ancillary staff on the correct procedures for the segregation, storage, transport and disposal of waste. He/she shall:
- Liaise with the WMO and the advisers (Infection Control Officer, Chief Pharmacist, and Radiation Officer) to maintain the highest standards in HCWM;
 - Participate in staff introduction to and continuous training in the handling and disposal of waste; and
 - Liaise with the Department Heads to ensure coordination of training activities, other waste management issues specific to particular departments.
- D. The Chief Pharmacist is responsible for the sound management of pharmaceutical storage and for pharmaceutical waste minimization. He/she shall:
- Liaise with the Department Heads, the WMO, the Senior Nursing Officer and give advice, in accordance with the national policy and guidelines, on the appropriate procedures for pharmaceutical waste disposal;
 - Coordinate continuous monitoring of compliance with procedures for the storage and disposal of pharmaceutical waste;
 - Ensure that personnel involved in pharmaceutical waste handling and disposal receive adequate training; and,
 - Ensure safe utilization of genotoxic products and safe management of genotoxic waste.

- E. The Radiation Officer shall:
- Ensure proper waste management of radioactive waste;
 - Liaise with the Department Heads, the WMO, the Senior Nursing Officer and give advice, in accordance with the national policy and guidelines, on the appropriate procedures for radioactive waste disposal including its continuous monitoring;
 - Ensure that personnel involved in radioactive waste handling and disposal receive adequate training.
- F. The Head of the General Services including the unit heads of housekeeping and janitorial services shall:
- Maintain cleanliness and orderliness of the HCF premises for aesthetic reasons;
 - Assist in the preparation of the HCWM Plan;
 - Initiate a sanitary manner of implementing the pre-treatment process, appropriate collection system/procedures and disposal of waste either by TSD or municipal system;
 - Establish baseline data, ensure generation of data for regular recording and monitoring; and maintain proper filing system and update program records;
 - Maintain constant good working relationship with all HCF workers for their support and full participation in implementing the program;
 - Enhance or provide continuous training for housekeeping/janitorial services on waste management and government policies.
- G. Maintenance and Ground Services shall:
- Assist in the proper collection, pre-treatment and disposal of HCW;
 - Carry out directly the activities related to the operation and maintenance of pre-treatment, collection and disposal system with importance to the drainage system and plumbing facilities of the establishment;
 - Attend immediately to problems arising from the repair/installation of waste equipment.
- H. The Motor Pool and Ground Services shall:
- Assist in the provision of vehicle for transporting HCW to transfer station or disposal sites;
 - Prepare and plan the collection system routes and frequency of collection of HCW;
 - Inspect and schedule maintenance work on vehicles used for transporting HCW;
 - Observe proper infection control measures in the maintenance of vehicles used for the transportation of HCW
- I. The HCF Engineer or the designated in-charge of engineering services shall:
- Be responsible for installing and maintaining waste storage facilities and comply with the specifications of the national guidelines;
 - Be accountable for the adequate operation and maintenance of any on-site waste treatment equipment;
 - Be responsible for compliance with mandatory requirements of pollution control;
 - Be responsible for the staff involved in waste treatment; ensure that the staff designated to operate the on-site waste treatment facilities are trained in their operation and maintenance.

Annex B 2: Requirements for Consignment Notes

- All HCW to be transported to an approved off-site waste treatment facility shall be transported only by a DENR-accredited transporter or carrier, except non-hazardous HCW which are collected by the municipal collection system.
- The authorized transporter/carrier shall maintain a completed consignment note of all HCW for treatment or disposal and an updated transport permit.
- Upon the receipt of the wastes, the transporter shall provide the waste generator with a copy of the consignment note for the generator's waste records.
- The transporter and generator shall separately maintain a copy of the consignment note. The consignment note shall include, but is not limited to the following information:
 - The name, address, telephone number and accreditation number of the transporter, unless the transporter is the generator.
 - The type and quantity of HCW transported;
 - The name, address, and telephone number of the generator;
 - The name, address, telephone number, permit number and the signature of an authorized representative of the approved facility receiving the HCW.
 - The date that the HCW is collected or removed from the generator's facility, the date that the HCW is received by the transfer station or point of consolidation (if applicable) and the date that the HCW is received by the treatment facility.
- If the HCW generator transports the waste or directs a member of its staff to transport the HCW to an approved waste treatment and disposal facility, the consignment note for the HCW shall show the name, address and telephone number of the HCW generator when the HCW are transported to the waste treatment and disposal facility.
- The transporter or generator transporting the HCW shall have the consignment note in his or her possession in the vehicle while transporting the waste. The tracking document shall be available upon demand by any traffic enforcement agency personnel. The transporter shall provide the facility receiving the waste with a copy of the original tracking document.

Annex B 3: Requirements of Off-site Transport Vehicles

A. Logistic Staff Requirements

Drivers of vehicles carrying hazardous HCW should have appropriate training about risks and handling of hazardous waste. Training on the following issues should be included:

- relevant legal regulations
- waste classifications and risks
- safe handling of hazardous waste
- labelling and documentation
- emergency and spillage procedures.

In addition, drivers should be declared medically fit to drive vehicles. In case of accident, contact numbers or details of the emergency services and other essential departments should be carried in the driver's cab. For safety reasons, vaccination against tetanus and hepatitis A and B is recommended, and vaccination and training details of staff should be recorded.

B. Requirements for Off-site Transport Vehicles

- Transport vehicles for HCW shall not be used for the transport of any other materials that could be seriously affected by contamination such as food, livestock, or retail goods.
- The vehicle shall have an enclosed leak-proof body and capable of being locked to secure the HCW. Open-topped skips or containers are unsuitable because they fail to isolate waste from the general public during transportation and should not be used for HCW.
- HCW can be loaded directly to a specially designed vehicle, but it is safer to place them first in containers (e.g. cardboard boxes or wheeled, rigid, lidded plastic or galvanized bins).
 - The design of the collection vehicle must conform to the following:
 - The body shall be of suitable size commensurate with the design of the vehicle.
 - It shall have a totally enclosed car body with the driver's seat separated from the load to prevent coming into contact with the HCW in the event of a collision/ accident.
 - The body of the vehicle shall display the international biohazard sign including emergency telephone number.
 - The body shall be marked with the name and address of the waste carrier.
 - It shall have a suitable system for securing the load during transport.
 - It shall be easy to clean. The internal surface of the body shall be smooth enough to allow it to be cleaned with wet steam or hot water.
 - The internal finish of the vehicle and internal angles should be rounded to eliminate sharp edges to permit more thorough cleaning and prevent damage to waste containers.
 - It shall be equipped with a separate compartment containing empty plastic bags, suitable protective clothing, cleaning equipment, tools, disinfectants and special kits for dealing with liquid spills.
 - It shall strictly comply with EMB-DENR requirements.
 - The same safety measures should apply to the collection of hazardous HCW from scattered small sources, such as clinics and general practice surgeries.
- The transport vehicle should be labelled according to the type of waste that is being transported. The label that is displayed will depend on the United Nations classification of the waste. No specific vehicle labelling is required if less than 333kg (i.e. the "gross dangerous goods charge") of infectious waste (UN 3291) is transported – although labelling is recommended. Vehicles transporting more than

333kg gross weight of infectious waste must be provided with warning plates.

- A warning plate should:
 - be not less than 250mm by 250mm, with a line of the same color as the symbol running 12.5mm inside the edge and parallel with it;
 - correspond to the label required for the dangerous goods in question with respect to color and symbol;
 - display the numbers prescribed for the dangerous goods on the corresponding label, in digits not less than 25mm high.

C. Emergency Contingency Plan for HCW Transporter

The development of a plan of action shall be considered in the event of an accidental spill, loss of containment, equipment failure or other unexpected circumstances. The owner/operator of vehicles used in the transport of HCW shall carry contingency plans for emergencies that address the following:

- Emergency response intervention cards (ERICards or ERICs) kept inside the driver's cab provide guidance on initial actions for responders and fire crews, because they are often the first to arrive at the scene of a hazardous waste transport accident. These cards provide reliable product-specific emergency information that otherwise may not be immediately available. (PROVIDE SAMPLE OF ERICs in the Annex)
- Plan for the disinfection of the truck and any contaminated surface if a leaking container is discovered.
- A notification list of individuals or agencies to be contacted in the event of a transport accident.
- Clean-up and decontamination of potentially contaminated surfaces, designation of back-up transport for the HCW, a description of the plans for the repackaging and labelling of HCW where bins are no longer intact.
- Procedures for the management of leaking container/s.
- Other EMB-DENR requirements.

Annex B 4: Guide Questions for Selection of Treatment Technology

- How important is volume reduction in choosing a technology? What is the ratio of HCW produced by your HCF to the HCW treated by the treatment technology? Is the technology dependent on the volume of waste?
- How would waste reduction programs affect the process? If the waste volume changes radically for any reason (e.g., reduced patient-days, merger, better waste minimization efforts) will this technology still be the treatment needed?
- Have workers from your HCF talked to colleagues at other HCFs about their treatment options, made comparisons, discussed technologies, contracts and services, as well as violation histories and ranges of service costs?
- What is the Philippine regulatory climate for on-site treatment technologies? (Some types of technologies require more complicated permits than others)
- Does your HCF have workers on-site that are trained and certified to fulfil the testing requirements, time, etc. involved in these permits? If not, consider those staffing and testing costs in your evaluation.
- How long has the treatment technology been effectively in use and where?
- What is the estimated "life" of this equipment?
- What volume of waste can the technology handle and treat?
- Will it always be operating at peak capacity or will there be wide variations in the amount of HCW treated?
- What are the operational cost implications of using this technology?
- What are the environmental and fiscal impacts of utilities usage (electricity, water, and sewer)?
- What is the safety and repair history of the waste treatment equipment?
- What worker safety and on-going equipment education are required and who provides it?
- What is/are the cost/s of equipment failure and need for a back-up or alternative system?
- Is waste fed into the treatment system automatically (by machine) or by hand (stop feed)?
- What impact does this have on your HCF workers limitations?
- Can equipment repair be completed within 24 hours without an emergency clause and/or additional costs?
- Does the technology require ancillary equipment such as shredders? Are they an integral part of the treatment process?
- What are the total associated costs for this equipment?
- Are there any worker-safety concerns with this equipment?
- How is the volume and weight of the HCW measured? Who measures it? Is it cost-effective to weigh the wastes on-site?

Annex B 5: Advantages and Disadvantages of Different Treatment Technologies

ADVANTAGES	DISADVANTAGES	HEALTH AND ENVIRONMENTAL IMPACT
Autoclave		
<ul style="list-style-type: none"> • Low environmental impacts • No hazardous residues • Complies with Stockholm Convention • Some treated wastes can be recycled 	<ul style="list-style-type: none"> • Reliable solid waste collection required • Reliable water and electricity connection needed • Water needs to be of certain quality to protect the equipment • Temperature resistant waste bin or bags are needed • Residue recognizable, can cause injuries (e.g., sharps) 	Autoclaving is an environmentally friendly technology. Low-heat thermal processes like autoclaving produce significantly less air pollution than incineration processes, therefore there are no specific pollutant emission limits for autoclaves. However, the air evacuated from the treatment chamber needs to be filtered and the condensate decontaminated to prevent occupational health hazards.
Autoclaves with Integrated Shredding		
<ul style="list-style-type: none"> • Low environmental impacts • No hazardous residues • Complies with Stockholm Convention • Reduction of Volume • Residue is unrecognizable 	<ul style="list-style-type: none"> • Reliable water and electricity connection needed • Water needs to be of certain quality to protect the equipment • Higher cost and maintenance • Requires skilled operator 	Since low-heat thermal processes like hybrid autoclaves produce significantly less air pollution than incineration processes, there are no specific pollutant emission limits for hybrid autoclaves. The system needs to be completely enclosed to prevent emitting aerosols during the waste shredding process
Batchwise Microwave		
<ul style="list-style-type: none"> • Low environmental impacts • No hazardous residues • Complies with Stockholm Convention 	<ul style="list-style-type: none"> • Reliable solid waste collection required • Reliable electricity connection needed • Waste needs a minimum humidity or water needs to be added • Special waste bins are needed 	Microwaving is an environmentally friendly technology. Wastewater is decontaminated during the process. Air emissions from microwave units are minimal. There are no pollutant emission limits specific for microwaves.
Continuous Microwave		
<ul style="list-style-type: none"> • Low environmental impacts • No hazardous residues • Residue is unrecognizable • Reduction of waste volume • Complies with Stockholm Convention 	<ul style="list-style-type: none"> • Reliable electricity connection needed • Waste needs a minimum humidity or water needs to be added • Higher cost and maintenance 	Microwaving is an environmentally friendly technology. Wastewater is decontaminated through the process. Air emissions from microwave units are minimal. There are no pollutant emission limits specific for microwaves. The system needs to be completely enclosed to prevent emission of aerosols during the waste shredding process.
Incineration		
<ul style="list-style-type: none"> • Reduction of waste volume • Residue is unrecognizable • Fully destroys infectious and sharps wastes 	<ul style="list-style-type: none"> • High environmental and health impact (air emissions and risk of burns) * • Bottom and fly ash is potentially hazardous • Not in accordance with 	Incinerators release a wide variety of pollutants, including dioxins and furans, into the atmosphere. Pollutants vary according to the composition of the waste. Bottom ash residues are also generally contaminated with dioxins, leachable organic compounds, and

ADVANTAGES	DISADVANTAGES	HEALTH AND ENVIRONMENTAL IMPACT
<ul style="list-style-type: none">• Applicable to some pharmaceutical and chemical wastes	<p>the Stockholm Convention*</p> <ul style="list-style-type: none">• *if no flue gas treatment	<p>heavy metals and must be treated as hazardous waste. The ash should be disposed in sites designed for hazardous wastes, e.g., designated cells at engineered landfills, encapsulated and placed in specialized monofill sites, or disposed in the ground in ash pits.</p>

Annex B 6: Characteristics of the Main Disinfectant Groups

SPECTRUM	ADVANTAGES	DISADVANTAGES
<p>Alcohols (60-90%) including ethanol or isopropanol</p> <ul style="list-style-type: none"> Used for some semicritical and noncritical items (e.g., oral and rectal thermometers and stethoscopes) Used to disinfect small surfaces such as rubber stoppers of multidose vials Alcohols with detergent are safe and effective for spot disinfection of countertops, floors and other surfaces 		
Low- to intermediate level disinfectant	<ul style="list-style-type: none"> Fast acting No residue No staining Low cost Readily available in all countries 	<ul style="list-style-type: none"> Volatile, flammable, and irritant to mucous membranes Inactivated by organic matter May harden rubber, cause glue to deteriorate, or crack acrylate plastic
<p>Chlorine and chlorine compounds: the most widely used is an aqueous solution of sodium hypochlorite 5.25- 6.15% (household bleach) at a concentration of 100-5000 ppm free chlorine</p> <ul style="list-style-type: none"> Used for disinfecting tonometers and for spot disinfection of countertops and floors Can be used for decontaminating blood spills Concentrated hypochlorite or chlorine gas is used to disinfect large and small water-distribution systems such as dental appliances, hydrotherapy tanks, and water-distribution systems in hemodialysis centers 		
Low- to high-level disinfectant	<ul style="list-style-type: none"> Low cost Fast acting Readily available in most settings Available as liquid, tablets or powders 	<ul style="list-style-type: none"> Corrosive to metals in high concentrations (>500 ppm) Inactivated by organic material Causes discoloration or bleaching of fabrics Releases toxic chlorine gas when mixed with ammonia Irritant to skin and mucous membranes Unstable if left uncovered, exposed to light or diluted; store in an opaque container
<p>Glutaraldehyde: ≥2% aqueous solutions buffered to pH 7.5- 8.5 with sodium bicarbonate Novel glutaraldehyde formulations include glutaraldehyde, phenol-sodium-phenate, potentiated acid glutaraldehyde, stabilized alkaline glutaraldehyde.</p> <ul style="list-style-type: none"> Used in automated endoscope reprocessors Can be used for cold sterilization of heat-sensitive critical items (e.g., hemodialyzers) Also suitable for manual instrument processing (depending on the formulation) 		
High-level disinfectant/sterilant	<ul style="list-style-type: none"> Rapid sterilization cycle time at low temperature (30–45 min. at 50–55°C) Active in presence of organic matter Environment friendly byproducts (oxygen, water, acetic acid) 	<ul style="list-style-type: none"> Corrosive to some metals Unstable when activated May be irritating to skin, conjunctiva and mucous membranes
<p>Orthophthalaldehyde (OPA) 0.55%</p> <ul style="list-style-type: none"> High-level disinfectant for endoscopes 		
High-level disinfectant/sterilant	<ul style="list-style-type: none"> Excellent stability over wide pH range No need for activation Superior mycobactericidal 	<ul style="list-style-type: none"> Expensive Stains skin and mucous membranes May stain items that are not

SPECTRUM	ADVANTAGES	DISADVANTAGES
	activity compared with glutaraldehyde Does not require activation	<p>cleaned thoroughly</p> <ul style="list-style-type: none"> • Eye irritation with contact • May cause hypersensitivity reactions in bladder cancer patients following repeated exposure to manually processed urological instruments • Slow sporicidal activity • Must be monitored for continuing efficacy levels
<p>Hydrogen peroxide 7.5%</p> <ul style="list-style-type: none"> • Can be used for cold sterilization of heat-sensitive critical items • Requires 30 min at 20°C 		
High-level disinfectant/sterilant	<ul style="list-style-type: none"> • No odor • Environment friendly byproducts (oxygen, water) 	<ul style="list-style-type: none"> • Material compatibility concerns with brass, copper, zinc, nickel/silver plating
<p>Hydrogen peroxide 7.5% and peracetic acid 0.23%</p> <ul style="list-style-type: none"> • For disinfecting hemodialysis 		
High-level disinfectant/sterilant	<ul style="list-style-type: none"> • Fast-acting (high-level disinfection in 15 min) • No activation required • No odor 	<ul style="list-style-type: none"> • Material compatibility concerns with brass, copper, zinc, and lead • Potential for eye and skin damage
<p>Glucoprotamin</p> <ul style="list-style-type: none"> • Used for manual reprocessing of endoscopes • Requires 15 min at 20°C 		
High-level disinfectant	<ul style="list-style-type: none"> • Highly effective against mycobacteria • High cleansing performance • No odor 	<ul style="list-style-type: none"> • Lack of effectiveness against some enteroviruses and spores
<p>Phenolics</p> <ul style="list-style-type: none"> • Have been used for decontaminating environmental surfaces and noncritical surfaces • Should be avoided 		
Low to intermediate level disinfectant	<ul style="list-style-type: none"> • Not inactivated by organic matter 	<ul style="list-style-type: none"> • Leaves residual film on surfaces • Harmful to the environment • No activity against viruses • Use in nurseries should be avoided due to reports of hyperbilirubinemia in infants
<p>Iodophores (30-50 ppm free iodine)</p> <ul style="list-style-type: none"> • Have been used for disinfecting some non-critical items (e.g., hydrotherapy tanks); however, they are used mainly as an antiseptic (2-3 ppm free iodine) 		
Low-level disinfectant	<ul style="list-style-type: none"> • Relatively free of toxicity or irritancy 	<ul style="list-style-type: none"> • Inactivated by organic matter • Adversely affects silicone tubing • May stain some fabrics

Annex B 7: Advantages and Disadvantages of Different Types of Wastewater Treatment Plant

WWTP TECHNOLOGY	ADVANTAGES	DISADVANTAGES
Anaerobic Baffled Reactor (ABR)	<ul style="list-style-type: none"> • Suitable for smaller and larger settlements • Little space required due to underground construction • Low investment costs • Very low operation and maintenance costs. No moving parts power needed. Hardly any blockage • Simple and durable • High treatment efficiency 	<ul style="list-style-type: none"> • Experts are required for the design and supervision • Master mason is required for water-tight plastering • Effluent is not completely odorless • Slow growth rate of anaerobic bacteria means long start-up period • Less efficient with weak wastewater
Waste Stabilization Ponds	<ul style="list-style-type: none"> • Simple to build, reliable and easy to maintain • Provides pathogen removal which is better than the conventional treatment • Used in small communities • Low in construction and operating cost 	<ul style="list-style-type: none"> • Large area requirement • Poor quality of treated effluent • May promote breeding of insects in the pond • Needs to be located far from communities
Engineered Reed Bed	<ul style="list-style-type: none"> • Easy and simple to maintain and operate • Low-cost secondary treatment option • Pleasant landscaping is possible 	<ul style="list-style-type: none"> • Requires larger land area • Low treatment efficiency • Professional/specialist needed in design and construction
Sequencing Batch Reactor (SBR)	<ul style="list-style-type: none"> • Efficient treatment • Tolerates hydraulic and organic shock loads (high inlet variation) • Modular construction facilitates future expansion Provides a simple, reliable, automatic, wastewater treatment process with a basin (simple design and construction) • Fully automatic (simple and easy control and operation) • Relatively small space requirement 	<ul style="list-style-type: none"> • Most of the component parts are patented and comes from abroad • Capacities are fixed and no flexibility • More expensive than other treatment methods • In case of power failure, reactor may overflow • Requires more skilled attention
Rotating Biological Contractors (RBC)	<ul style="list-style-type: none"> • Low space requirement • Can withstand hydraulic and organic surges more effectively • High treatment efficiency • Low energy and maintenance requirement • Well drainable excess sludge 	<ul style="list-style-type: none"> • Contact media are not readily available in the market • High capital cost of equipment • Must be covered for protection against rain, wind, sunlight, and vandalism • Failures in shaft and media • Odor problems
Sludge Drying Bed	<ul style="list-style-type: none"> • Simple to operate • Lowest cost option among sludge dewatering methods • Energy-saving 	<ul style="list-style-type: none"> • Filtrate/seepage water must be treated • Requires solar power • May produce odor and flies nuisance

Annex B 8: Factors to Consider for Establishment of On-Site WWTP

- a) Regulatory Requirements: Prior to application for Discharge Permit, the following shall be secured:
- b) Environmental Compliance Certificate (ECC) or Certificate of Non-Coverage
- c) Application Form from DENR or LLDA
- d) Designated and Accredited Pollution Control Officer (PCO - Curriculum Vitae - Undergo 40 hours accreditation training course by DENR or LLDA 4. Working Plan signed by Professional Mechanical Engineer (PME)
- e) Engineer's Report
- f) Submission of Quarterly Self-Monitoring Report to LLDA
- g) Location of the treatment and disposal facility: Under the latest Fire Code of the Philippines, underground or basement WWTP must be avoided for the following reasons:
- h) Possible accumulation of methane gas during breakdown
 - i) Difficult to access, thus delaying the response during emergency
 - j) Risk on the part of the full time WWTP operator due to the poor indoor air quality in basements
- k) Space Availability: This determines the technology/type or treatment given the volume and characteristic of wastewater. Smaller space available requires a more compact type of WWTP.
- l) Infrastructure Requirements: Generally, upon construction, WWTP chambers shall be waterproofed and can withstand pressure of air blowers and pumping during operation. It is necessary to provide an air vent in air diffusers to avoid fatigue of the blower component. Proper ventilation and lighting illumination are also necessary. Proper warning and signage in strategic areas must be provided.
- m) Locally available equipment and parts: In selecting WWTP technology, the Terms of Reference (TOR), should include the criteria that the equipment parts must be readily available in the local market for at least five (5) years. This will ensure that there will be a supply of equipment parts in cases when repairs are needed.
- n) Treatment Efficiency: The main objective of treating wastewater is to prevent pollution and protect the receiving body of water. This can be achieved by maintaining treatment efficiency that meets the DENR/EMB/LLDA effluent standards.
- o) Quantity of Wastewater for Treatment and Disposal: The influent of wastewater for treatment and disposal depends on the day to day consumption of water.
- p) Reuse of Treated Wastewater: Treated wastewater can be used for cooling towers, watering of ornamental plants and trees, cleaning of hospital buildings and grounds and for flushing of urinals and toilets. Separate piping for toilets is necessary in using treated wastewater. By using treated wastewater, over extraction of groundwater and preserved water resources can be prevented.
- q) Characteristic of Wastewater for Treatment: In order to select the best technology option, there is need to know the characteristics of the HCF's wastewater through water analysis.
- r) Sludge and Septage Disposal: Disposal of accumulated sludge and septage shall be included in the selection of WWTP technology in compliance with the IRR of Chapter 17 of PD856 and the Operational Manual on Sludge and Septage Treatment.
- s) Operation and Maintenance: It is important to hire a WWTP Operator or a service provider for the efficient operation and maintenance, monitoring and recording of parameters. It is a must to have a readily available consumable stock of needed equipment and treatment materials for continuous WWTP operation.
- t) Training Requirement for Operation: It is the responsibility of the awarded contractor to conduct the on-site or off-site training for the service, operation and proper preventive maintenance of the WWTP. In compliance with the DENR requirements, the WWTP operator shall undergo training before renewal of the discharge permit. A newly hired or newly assigned operator must first undergo training with the DENR.
- u) Investment and Operating Cost: Since it is a mandatory requirement of the government, the management of the HCF shall allocate a budget for the acquisition and maintenance of the WWTP. Maintenance cost, manpower and operational (electrical and water) costs of the WWTP shall be included in the annual budget of the HCF.

Annex B 9: Suggested Training Package for HCWM Target Group

The development of a training package shall be suitable for the various types of HCFs.

For Personnel Providing Health Care

The training course shall provide an overview of the waste management policy and underlying rationale and information on practices relevant to trainees' responsibilities. Waste segregation is a key element for this training in waste management. All HCF workers that generate HCW shall be responsible for its segregation and shall therefore receive training in the basic principles and practical applications of segregation. Training shall make the staff aware of the potentially serious implications of the mismanagement of waste to the health of waste handlers and patients; provide them with an overview of the fate of waste after collection and removal from the ward and teach them the importance of proper segregation.

For Waste Handlers

Topics covered may include the waste management policy, health hazards, on-site transportation, storage, safety practices and emergency response. Among staffs who routinely handle HCW, awareness of the need for safety may decrease with time, which will increase the risk of injury. Periodic refresher course is therefore recommended.

For Health Care Waste Management Operators

The training course shall include:

- Information of the risk associated with the handling of HCW;
- Procedures for dealing with spillage and other accidents;
- Correct use of protective clothing.

For Staff Who Transport the Waste

In carrying out the responsibility of waste transportation, the drivers and waste handlers shall be aware of the nature and risk of the transported waste. Transport staff shall be able to carry out all procedures for:

- Handling, loading and unloading of waste bags and bins;
- Dealing with spillage or accidents;
- The use of PPE; and
- Documentation and recording of HCW, e.g. by means of consignment note system to allow waste to be traced from the point of collection to the final place of disposal.

For Treatment Plant Operators

HCFs shall make arrangements to provide training to prospective treatment plant operators specifically on the following areas:

- General operations of the treatment facility;
- Health, safety and environmental implications of treatment operations;
- Technical procedures for plant operations;
- Emergency response, in case of equipment failures and/or alarms;
- Maintenance of the plant and record keeping;
- Surveillance of the quality of emissions and discharges, according to the specifications.

Orientation Module for Patients

HCF shall provide patients and watchers an orientation of the HCWM policies and system of the hospital as part of the admission procedure. The orientation will include, at the minimum:

- Policies on HCWM relevant to patients and watchers such as the ban on Styrofoam and non-reusable plastic food containers, proper segregation of waste
- Impact of improper segregation and Styrofoam/non-reusable plastic food containers on health, safety and environment.

ANNEX C: Procedures

Annex C 1: Standard Precaution in Health Care

Annex C 2: Procedure for Proper Hand Rubbing

Annex C 3: Procedure for Proper Hand Washing

Annex C 4: Procedures for Spill Control

Annex C 5: General Procedure for Emergency Response to Spills

Annex C 6: Procedures for Emergency Response to Specific Waste Spills

Annex C 7: Procedure for Emergency Response to Needle Prick Injury

Annex C 1: Standard Precaution in Health Care

AIDE-MEMOIRE

OCTOBER 2007 INFECTION CONTROL

Standard precautions in health care

Background

Standard precautions are meant to reduce the risk of transmission of bloodborne and other pathogens from both recognized and unrecognized sources. They are the basic level of infection control precautions which are to be used, as a minimum, in the care of all patients.

Hand hygiene is a major component of standard precautions and one of the most effective methods to prevent transmission of pathogens associated with health care. In addition to hand hygiene, the use of **personal protective equipment** should be guided by **risk assessment** and the extent of contact anticipated with blood and body fluids, or pathogens.

In addition to practices carried out by health workers when providing care, all individuals (including patients and visitors) should comply with infection control practices in health-care settings. The control of spread of pathogens from the source is key to avoid transmission. Among source control measures, **respiratory hygiene/cough etiquette**, developed during the severe acute respiratory syndrome (SARS) outbreak, is now considered as part of standard precautions.

Worldwide escalation of the use of standard precautions would reduce unnecessary risks associated with health care. Promotion of an **institutional safety climate** helps to improve conformity with recommended measures and thus subsequent risk reduction. Provision of adequate staff and supplies, together with leadership and education of health workers, patients, and visitors, is critical for an enhanced safety climate in health-care settings.

Important advice

- Promotion of a safety climate is a cornerstone of prevention of transmission of pathogens in health care.
- Standard precautions should be the minimum level of precautions used when providing care for all patients.
- Risk assessment is critical. Assess all health-care activities to determine the personal protection that is indicated.
- Implement source control measures for all persons with respiratory symptoms through promotion of respiratory hygiene and cough etiquette.

✓ Checklist

Health policy

- Promote a safety climate.
- Develop policies which facilitate the implementation of infection control measures.

Hand hygiene

- Perform hand hygiene by means of hand rubbing or hand washing (see detailed indications in table).
- Perform hand washing with soap and water if hands are visibly soiled, or exposure to spore-forming organisms is proven or strongly suspected, or after using the restroom. Otherwise, if resources permit, perform hand rubbing with an alcohol-based preparation.
- Ensure availability of hand-washing facilities with clean running water.
- Ensure availability of hand hygiene products (clean water, soap, single use clean towels, alcohol-based hand rub). Alcohol-based hand rubs should ideally be available at the point of care.

Personal protective equipment (PPE)

- ASSESS THE RISK of exposure to body substances or contaminated surfaces BEFORE any health-care activity. **Make this a routine!**
- Select PPE based on the assessment of risk:
 - clean non-sterile gloves
 - clean, non-sterile fluid-resistant gown
 - mask and eye protection or a face shield.

Respiratory hygiene and cough etiquette

- Education of health workers, patients and visitors.
- Covering mouth and nose when coughing or sneezing.
- Hand hygiene after contact with respiratory secretions.
- Spatial separation of persons with acute febrile respiratory symptoms.



EPIDEMIC AND PANDEMIC ALERT AND RESPONSE

© World Health Organization 2007

Health-care facility recommendations for standard precautions

KEY ELEMENTS AT A GLANCE

1. Hand hygiene¹

Summary technique:

- Hand washing (40–60 sec): wet hands and apply soap; rub all surfaces; rinse hands and dry thoroughly with a single use towel; use towel to turn off faucet.
- Hand rubbing (20–30 sec): apply enough product to cover all areas of the hands; rub hands until dry.

Summary indications:

- Before and after any direct patient contact and between patients, whether or not gloves are worn.
- Immediately after gloves are removed.
- Before handling an invasive device.
- After touching blood, body fluids, secretions, excretions, non-intact skin, and contaminated items, even if gloves are worn.
- During patient care, when moving from a contaminated to a clean body site of the patient.
- After contact with inanimate objects in the immediate vicinity of the patient.

2. Gloves

- Wear when touching blood, body fluids, secretions, excretions, mucous membranes, nonintact skin.
- Change between tasks and procedures on the same patient after contact with potentially infectious material.
- Remove after use, before touching non-contaminated items and surfaces, and before going to another patient. Perform hand hygiene immediately after removal.

3. Facial protection (eyes, nose, and mouth)

- Wear (1) a surgical or procedure mask and eye protection (eye visor, goggles) or (2) a face shield to protect mucous membranes of the eyes, nose, and mouth during activities that are likely to generate splashes or sprays of blood, body fluids, secretions, and excretions.

4. Gown

- Wear to protect skin and prevent soiling of clothing during activities that are likely to generate splashes or sprays of blood, body fluids, secretions, or excretions.
- Remove soiled gown as soon as possible, and perform hand hygiene.

5. Prevention of needle stick and injuries from other sharp instruments²

Use care when:

- Handling needles, scalpels, and other sharp instruments or devices.
- Cleaning used instruments.
- Disposing of used needles and other sharp instruments.

6. Respiratory hygiene and cough etiquette

Persons with respiratory symptoms should apply source control measures:

- Cover their nose and mouth when coughing/sneezing with tissue or mask, dispose of used tissues and masks, and perform hand hygiene after contact with respiratory secretions.

Health-care facilities should:

- Place acute febrile respiratory symptomatic patients at least 1 metre (3 feet) away from others in common waiting areas, if possible.
- Post visual alerts at the entrance to health-care facilities instructing persons with respiratory symptoms to practise respiratory hygiene/cough etiquette.
- Consider making hand hygiene resources, tissues and masks available in common areas and areas used for the evaluation of patients with respiratory illnesses.

7. Environmental cleaning

- Use adequate procedures for the routine cleaning and disinfection of environmental and other frequently touched surfaces.

8. Linens

Handle, transport, and process used linen in a manner which:

- Prevents skin and mucous membrane exposures and contamination of clothing.
- Avoids transfer of pathogens to other patients and/or the environment.

9. Waste disposal

- Ensure safe waste management.
- Treat waste contaminated with blood, body fluids, secretions and excretions as clinical waste, in accordance with local regulations.
- Human tissues and laboratory waste that is directly associated with specimen processing should also be treated as clinical waste.
- Discard single use items properly.

10. Patient care equipment

- Handle equipment soiled with blood, body fluids, secretions, and excretions in a manner that prevents skin and mucous membrane exposures, contamination of clothing, and transfer of pathogens to other patients or the environment.
- Clean, disinfect, and reprocess reusable equipment appropriately before use with another patient.

¹ For more details, see: WHO Guidelines on Hand Hygiene in Health Care (Advanced draft), at: http://www.who.int/patientsafety/information_centre/ghhad_download/en/index.html.

² The SIGN Alliance at: http://www.who.int/injection_safety/sign/en/

Annex C 2: Procedure for Proper Hand Rubbing

How to Handrub?

RUB HANDS FOR HAND HYGIENE! WASH HANDS WHEN VISIBLY SOILED

 Duration of the entire procedure: 20–30 seconds



1a Apply a palmful of the product in a cupped hand, covering all surfaces



2 Rub hands palm to palm



3 Right palm over left dorsum with interlaced fingers and vice versa



4 Palm to palm with fingers interlaced



5 Backs of fingers to opposing palms with fingers interlocked



6 Rotational rubbing of left thumb clasped in right palm and vice versa



7 Rotational rubbing, backwards and forwards with clasped fingers of right hand in left palm and vice versa



8 Once dry, your hands are safe

 **World Health Organization**

Patient Safety
A World Alliance for Safer Health Care

SAVE LIVES
Clean Your Hands

All reasonable precautions have been taken by the World Health Organization to verify the information contained in this document. However, the published material is being distributed without warranty of any kind, either expressed or implied. The responsibility for the interpretation and use of the material lies with the reader. In no event shall the World Health Organization be liable for damages arising from its use.
WHO acknowledges the Instituto Universitario de Genova (IUGG), in particular the members of the Infection Control Programme, for their active participation in developing this material.

May 2009

Source: WHO (2009)

Annex C 3: Procedure for Proper Hand Washing

How to Handwash?

WASH HANDS WHEN VISIBLY SOILED! OTHERWISE, USE HANDRUB

 Duration of the entire procedure: 40–60 seconds



0 Wet hands with water



1 Apply enough soap to cover all hand surfaces



2 Rub hands palm to palm



3 Right palm over left dorsum with interlaced fingers and vice versa



4 Palm to palm with fingers interlaced



5 Backs of fingers to opposing palms with fingers interlocked



6 Rotational rubbing of left thumb clasped in right palm and vice versa



7 Rotational rubbing, backwards and forwards with clasped fingers of right hand in left palm and vice versa



8 Rinse hands with water



9 Dry hands thoroughly with a single use towel



10 Use towel to turn off faucet



11 Your hands are now safe



World Health
Organization

Patient Safety

A World Alliance for Safer Health Care

SAVE LIVES

Clean Your Hands

All reasonable precautions have been taken by the World Health Organization to verify the information contained in this document. However, the published material is being distributed without warranty of any kind, either expressed or implied. The responsibility for the interpretation and use of the material lies with the reader. In no event shall the World Health Organization be liable for damages arising from its use.

WHO acknowledges the Hospitales Universitarios de Córdoba (HUCO), in particular the members of the Infection Control Programme, for their active participation in developing this material.

May 2009

Annex C 4: Procedures for Spill Control

General procedure for dealing with spillages:

- a) Vacate and secure the area to prevent further exposure of other individuals.
- b) Provide first aid and medical care to injured individuals.
- c) Inform WMO who shall coordinate the necessary actions.
- d) Determine the nature of the spill. Refer to the MSDS if necessary.
- e) Provide appropriate clothing to personnel involved in cleaning-up.
- f) Limit the spread of the spill.
- g) Activate exhaust system or keep the area well-ventilated particularly if the spill is due to volatile organic solvents or corrosive agents.
- h) Neutralize or disinfect the spilled or contaminated material if indicated.
- i) Collect all spilled and contaminated materials (sharps shall never be picked up by hand; brushes and pans or other suitable tools shall be used). Spilled materials and disposable contaminated items for cleaning shall be placed in appropriate waste bags or containers and properly labelled and documented before final disposal.
- j) Decontaminate or disinfect the area, wiping with absorbent cloth. The cloth (or other absorbent material) shall NOT be turned during this process, because this will spread the contamination. Work from the least to the most contaminated part of the spill while changing cloth at each stage to carry out the decontamination. Dry cloth shall be used in the case of liquid spillage and spillage of solids, while wet cloth shall be used for acidic, base or neutral chemicals.
- k) Decontaminate or disinfect all tools used.
- l) Seek medical attention if exposure to hazardous material has occurred during the operation.
- m) Normal operation may continue once the disinfected area is thoroughly cleaned and dried.

The clean-up kit for spill shall contain the following items:

- a) One (1) pair of latex gloves
- b) One (1) N95 mask (for blood, body fluids and chemotherapeutics/cytotoxics spills)
- c) Respirator with specific filter for the type of chemicals
- d) One (1) Zip lock bag – small
- e) One (1) Zip lock bag – big
- f) Absorbable cloth
- g) Appropriate disinfectant solution for spills due to blood, body fluids and chemotherapeutics/cytotoxics
- h) Neutralizing solution specific for acids or alkali
- i) Eye goggles (for big spill)
- j) Labeling materials
- k) Small pail with putty clay at the bottom (for chemical spill)
- l) Miscellaneous items which the HCF may require to meet their need

Annex C 5: General Procedure for Emergency Response to Spills

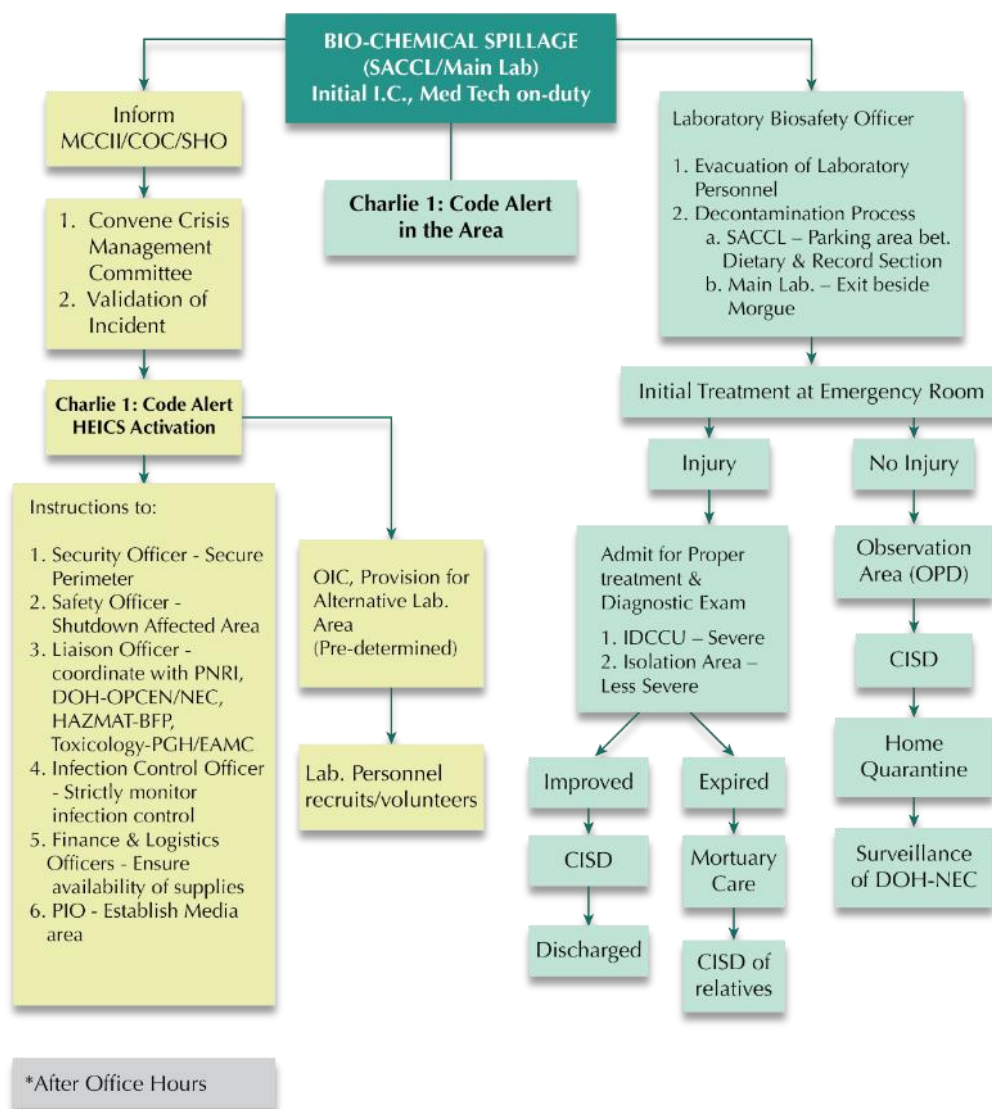

Annex C 6: Procedures for Emergency Response to Specific Waste Spills

TYPE OF WASTE SPILL	IMMEDIATE RESPONSE	FOLLOW-UP PROCEDURES	PERSON IN-CHARGE
Biohazardous Waste Spill			
Minor spill - occurs inside biosafety cabinet, no one is exposed	<ul style="list-style-type: none"> • Make sure that the biosafety cabinet continues to operate • If only a small quantity is spilled, decontaminate the surfaces within the cabinet, wearing gloves and using 16% bleach solution • If a large quantity is spilled, entire cabinet including fans, filters, airflow plenums, will need to be decontaminated (40% solution required) 	<ul style="list-style-type: none"> • Know the nature of the organism involved • Report to the person-in-charge 	Infection Control Office
Major spill – occurs outside the biosafety cabinet, people are exposed	<ul style="list-style-type: none"> • Evaluate the room, breathing as little as possible of any aerosols • Close the door of the room. Remove any and all contaminated clothing and place it in sealed plastic containers • Thoroughly wash hands and face with disinfectant soap. Shower if necessary. 	<ul style="list-style-type: none"> • Know the nature of the organism involved • Report to the person-in-charge 	Infection Control Office
Chemical Waste Spills			
Corrosive (acids and bases)	<ul style="list-style-type: none"> • If corrosive gets contact with eyes, go immediately to eyewash stations • Remove contact lenses, if any • Flush eyes for 15-20 minutes 	<ul style="list-style-type: none"> • Do not apply any neutralizers or ointments to the eyes • Seek medical attention 	Safety Officer
Reactive (explosives, oxidizers, unstable chemicals)	<ul style="list-style-type: none"> • Leave the area quickly • Close the doors • Go directly to the eyewash stations, shower or fresh air area 	<ul style="list-style-type: none"> • Inform person-in-charge • Seek medical attention 	Safety Officer
Toxins and Poisons	<ul style="list-style-type: none"> • If inhaled, go to fresh air area right away • If swallowed, seek medical help immediately • If it got into your eyes, go to the nearest eyewash station. Remove contact lenses, if any. Flush eyes for 15-20 minutes. • If on skin, don't rub the affected area. Rinse with running water for 15-20 minutes. • Remove all contaminated clothing. 	<ul style="list-style-type: none"> • Get medical help. • If swallowed, do not induce vomiting nor eat/drink anything unless instructed to do so in the MDS or by medical personnel. 	Safety Officer

Annex C 7: Procedure for Emergency Response to Needle Prick Injury

Needle stick safety shall always be a priority. The following steps in handling a needle stick injury are highly recommended.

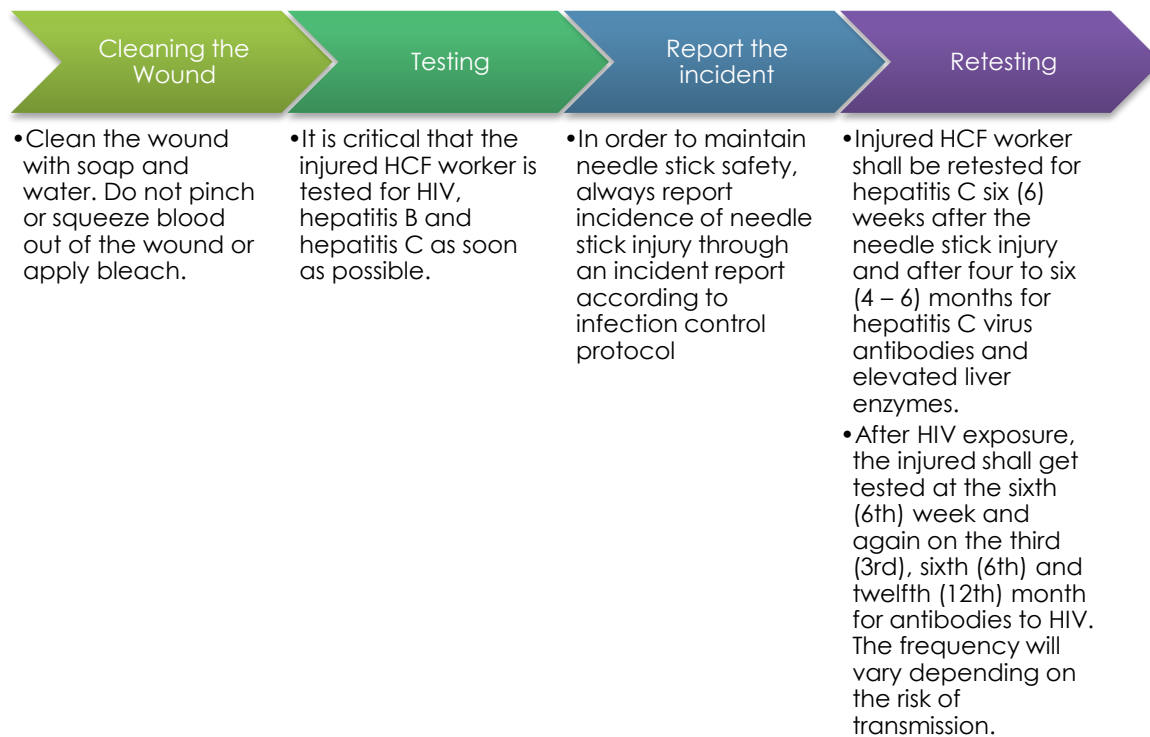

ANNEX D: Sample Checklists and Forms

- Annex D 1: Sample Assessment Checklist for Small HCFs for the Development of HCWM
- Annex D 2: Sample Sheet for Assessment of Waste Generation
- Annex D 3: Sample Consignment Note Template
- Annex D 4: HCWM Program Self-Monitoring Sheet
- Annex D 5: Sample Monitoring Tool for Waste Collector
- Annex D 6: Occupational Incident/Accident Report (OIR) Form

Annex D 1: Sample Assessment Checklist for Small HCFs for the Development of HCWM

Name of HCF: Type of HCF: Location:	
General Information	
Number of employees/workers	
Bed capacity	
Bed occupancy rate	
List all medical and supporting departments of the facility. (including pharmacy, laboratories, kitchen etc.)	
Health Care Waste Management	
What are the wastes generated daily by each department or ward/lab in the HCF? (Please check)	<input type="checkbox"/> General non-infectious wastes <input type="checkbox"/> Sharps <input type="checkbox"/> Pharmaceutical wastes <input type="checkbox"/> Chemical wastes <input type="checkbox"/> Pathological wastes <input type="checkbox"/> Anatomical wastes
How much is generated per type of waste by each department or ward/lab in the HCF? (kg/day)	<input type="checkbox"/> General non-infectious wastes <input type="checkbox"/> Sharps <input type="checkbox"/> Pharmaceutical wastes <input type="checkbox"/> Chemical wastes <input type="checkbox"/> Pathological wastes <input type="checkbox"/> Anatomical wastes
Is the HCF practicing segregation at point source?	
Are there functional waste collection containers in close proximity to all waste generation points for non-infectious wastes, infectious waste and sharp wastes?	
How and where is the facility's HCW stored before collection?	
Are the wastes stored separately?	
Are all the infectious wastes stored in a protected area before treatment for no longer than the default and safe time?	
How is hazardous liquid waste handled? Specify for chemical waste, cytotoxic waste, reagents, and used x-ray film processing liquids. If the liquid waste is discharged in the sanitation system, where does the latter discharge and what is its capacity?	
HCWM Treatment and Disposal	
What acceptable treatment technology (if any) are done to the wastes before disposal?	
Is the HCW disposed of at the HCF or off-site?	
If the wastes are disposed at the facility: Are concrete vaults used for the disposal of sharp wastes? Are placentas disinfected prior to disposal to placenta pit? Are treated infectious wastes, sharps, chemical and pharmaceutical waste encapsulated/inertized and disposed through	

safe burial?	
If any waste is taken off-site, are the wastes transported for treatment by a DENR-accredited transporter? How is the waste packaged? What types of vehicles are used to transport the waste?	
Is any of the waste taken to a dump or landfill site? If so, what happens to the waste at this facility? Is the HCW buried immediately after arriving at the landfill/dump? Is it burned on the site? Is it left unattended at any time after being unloaded? Do waste pickers, children, or others have access to the HCF?	
Wastewater Management	
What are the uses of water in the facility?	
What departments/wards in the HCF that generate wastewater? Estimate volume generated.	
Is the wastewater treated on-site or treated in a centralized wastewater treatment facility?	
Management	
Is there a trained person responsible for the management of health care wastes in the health care facility?	
How many people are involved in waste collection and are special skills required by the HCF? What sort of worker safety measures are in place?	
What are the current operational standards for HCW and what are the applicable national, regional, and local policies?	
Are there any written standard operating procedures for the segregation, storage, treatment and disposal of the health care wastes?	
Are appropriate protective equipment provided to all staff in charge of the waste management?	
Is procurement of new health care materials reviewed to reduce the waste stream and to avoid potential treatment problems (such as PVC)?	
What are the daily waste collection routines, including waste packaging?	
How much does HCW management cost the facility? Does the budget provision cover these costs?	
Risks of the current waste management system	
Does the management of the HCF have concerns about the facility's current HCW practices? If so, what problems do they identify?	
Does the assessment above indicate that the facility's current waste management practices	

pose any health risks to patients, nurses or doctors, other staff, or visitors? If yes, what kind of risks?	
Does the waste pose any risk to waste collectors? If yes, what kind?	

Source:

Health Care Waste Management Guidance Note (World Bank, 2000)

Water and Sanitation for Health Facility Improvement Tool (WHO, 2018)

Annex D 2: Sample Sheet for Assessment of Waste Generation

Name of the facility:								
Week:								
Waste collection point: Department/location	Waste category	Quantity of waste generated per day (weight/volume)						
		Mon	Tue	Wed	Thurs	Fri	Sat	Sun

Annex D 3: Sample Consignment Note Template

<p>A. <u>TRANSPORTER</u></p> <p>Name: _____</p> <p>Address: _____</p> <p>Telephone No.: _____ Accreditation No.: _____</p> <p>Type of Waste Transported: _____ Quantity (kg): _____</p> <p>B. <u>GENERATOR</u></p> <p>Name: _____</p> <p>Address: _____</p> <p>Telephone No.: _____</p> <p>C. <u>TREATMENT FACILITY</u></p> <p>Name of Manager/Authorized Representative: _____</p> <p>Address: _____ Telephone No.: _____</p> <p>Permit to Operate: (Permit No.) _____</p> <p>Signature of Manager/Authorized Representative:</p> <p>_____</p> <p>D. <u>DATE WASTES ARE COLLECTED/TRANSPORTED/RECEIVED</u></p> <p>Date Collected/Removed from Generator's Facility:</p> <p>_____</p> <p>Date Received by the Transfer Station (Point of Consolidation):</p> <p>_____</p> <p>Date Received by the Treatment Facility:</p> <p>_____</p>
--

Annex D 4: HCWM Program Self-Monitoring Sheet

AREA OF THE HOSPITAL: _____			
DATE OF INSPECTION: _____		MONITORING RATING: _____	
	SCORE		INDICATORS
	Reference	Actual	
A. WASTE MINIMIZATION PRACTICES	20%		
1. Re-uses/recycles used containers, articles, papers, etc.	10		% of recyclable wastes that were recycled multiplied to 0.10
2. Use of only environment friendly products and materials	10		No Styrofoam (polystyrene) and plastic (PVC) = 5, otherwise, the score is 0; and No mercury containing devices used = 5, otherwise, the score is 0
B. WASTE SEGREGATION	25%		
1. Waste properly segregated in correct plastic liners • <i>Black/Clear:</i> Non-Biodegradable General Waste • <i>Green:</i> Biodegradable General Waste • <i>Yellow:</i> Infectious Waste	5		No mixed wastes seen at all times= 5, otherwise, the score is 0
2. Color-coded plastic liners with proper tagging and labeling	4		Color coding and proper tagging and labeling strictly followed at all times= 4, otherwise, the score is 0
3. Use puncture-resistant and leak- proof sharps container for sharps	4		Only puncture-resistant and leak-proof sharps container used for sharps waste = 4, otherwise the score is 0
4. Waste bins strategically placed in designated area	4		Waste bins are placed in strategically designated areas = 4, otherwise, the score is 0
5. Proper segregation of recyclable items	4		Proper segregation practiced at all times= 4, otherwise, the score is 0
6. Empty vials brought to the pharmacy section by the nursing attendant/personnel-in-charge for proper recording and crushing (logbook available)	4		Proper management of empty vials practiced at all times= 4, otherwise, the score is 0
C. WASTE ON-SITE COLLECTION, TRANSPORT AND STORAGE	20%		
1. On-site collection scheduled strictly followed	2		Strict adherence to on-site collection schedule = 2, otherwise, the score is 0
2. Janitorial Service uses standard trolley with enclosure in collecting waste	3		Standard trolley is used to collect waste on- site= 3, otherwise, the score is 0
3. Janitorial Service directly transports waste collected to Central Storage Area	3		Waste is directly transported to Central Storage Area= 3, otherwise, the score is 0
4. No presence of spillage during collection and transport	3		No occurrence of spillage during collection and transport= 3, otherwise, the score is 0
5. Waste bins thoroughly cleaned/ washed by janitors	3		Waste bins thoroughly cleaned at all times= 3, otherwise, the score is 0
6. Waste transportation route followed	3		Waste transportation route

			strictly followed at all times= 3, otherwise, the score is 0														
7. Final disposal of waste in approved DENR facility	3		Final disposal of waste in accredited DENR facility= 3, otherwise, the score is 0														
D. WASTE TREATMENT ON SITE (If applicable)	10%																
1. Treatment of highly infectious waste conducted	4		Highly infectious waste treated at all times= 4, otherwise, the score is 0														
2. In case of chemical disinfection, used only allowed chemicals such as Sodium Hypochlorite, Chlorine Dioxide and Hydrogen Peroxide	3		Only the allowed chemicals are used for chemical disinfection= 3, otherwise, the score is 0														
3. In case of the use of microwave or autoclave, the equipment has passed the validation test	3		Equipment has passed the validation test= 3, otherwise, the score is 0														
E. WASTEWATER MANAGEMENT (Personnel in- charge)	15%																
1. Regular testing of effluents	5		Effluents tested regularly= 5, otherwise, the score is 0														
2. Preventive maintenance schedule for Sewage Treatment Plant (STP) followed	10		Strict adherence to STP maintenance schedule= 10, otherwise, the score is 0														
F. ADMINISTRATIVE	10%																
1. Staff with formal training and education on proper health care waste management (HCWM)	2		Staff had undergone formal training and education on proper HCWM= 2, otherwise, the score is 0														
2. Infection control protocol observed and practiced	4		Strict adherence to infection control protocols at all times= 4, otherwise, the score is 0														
3. Posters and other IEC materials available on-site	2		On-site presence and visibility of posters and other IEC materials= 2, otherwise, the score is 0														
4. Accident/incident reports submitted if any	2		Prompt submission of complete accident/ incident reports, if any= 2, otherwise, the score is 0														
TOTAL PERCENTAGE	100%																
Monitoring Team: _____																	
Signature of Area Supervisor: _____																	
<table border="1"> <thead> <tr> <th colspan="2">Monitoring Rating</th> </tr> <tr> <th colspan="2">Grade/Actual Score/Interpretation</th> </tr> </thead> <tbody> <tr> <td>100%</td> <td>Excellent with full compliance</td> </tr> <tr> <td>91%-99%</td> <td>Highly satisfactory with highly adequate compliance</td> </tr> <tr> <td>81%-90%</td> <td>Satisfactory with adequate compliance</td> </tr> <tr> <td>75%-80%</td> <td>Fair with compliance</td> </tr> <tr> <td>74% and below</td> <td>Poor with low compliance</td> </tr> </tbody> </table>				Monitoring Rating		Grade/Actual Score/Interpretation		100%	Excellent with full compliance	91%-99%	Highly satisfactory with highly adequate compliance	81%-90%	Satisfactory with adequate compliance	75%-80%	Fair with compliance	74% and below	Poor with low compliance
Monitoring Rating																	
Grade/Actual Score/Interpretation																	
100%	Excellent with full compliance																
91%-99%	Highly satisfactory with highly adequate compliance																
81%-90%	Satisfactory with adequate compliance																
75%-80%	Fair with compliance																
74% and below	Poor with low compliance																

Annex D 5: Sample Monitoring Tool for Waste Collector

Part 1															
AREA OF THE HOSPITAL: _____															
MONTH OF COLLECTION: _____ AREA SUPERVISOR: _____															
Date	Time	Volume of Waste													
		I	S	P	A	PH (A)	PH (B)	PH (C)	C	Hg	R	G(A)	G(B)	G(C)	G (D)
Legend															
I – Infectious Waste								C – Chemical Waste							
S – Sharps								Hg – Mercury and Other Heavy Metals							
P – Pathological Waste								R – Radioactive Waste							
A – Anatomical Waste								G (A) – Biodegradable/ Food Waste							
PH (A) – Pharmacological Waste (Expired/Used Drugs)								G (B) – Non-biodegradable/ Recyclable Waste							
PH (B) – Pharmacological Waste (Cytotoxic/Genotoxic/Antineoplastic)								G (C) – Non-biodegradable/ Non-Recyclable Waste							
PH (C) – Pharmacological Waste (Empty Vials/Ampoules)								G (D) – Aerosol and Pressurized Containers							

Part 2			
DATE	TIME	CHECK IF "YES" IF NOT, PROVIDE EXPLANATION	NAME AND SIGNATURE OF COLLECTOR
		Is proper segregation practiced? If not Improper practice/s:	
		Is the supply of liners adequate? # of liners left: Yellow: ___ Green: ___ Black: ___ Brown: ___ If not, # liners needed: Yellow: ___ Green: ___ Black: ___ Brown: ___	
		Are bins cleaned after collection? If not:	
		Are trolleys cleaned after collection? If not:	
		Is disinfectant used? Type of disinfectant: Concentration of disinfectant:	
		Are the bins in good condition? If not, repairs needed:	
		Are PPEs used? If not:	
		Are the PPEs in good condition? If not, repairs/new equipment needed:	
		Is proper segregation practiced? If not Improper practice/s:	
		Is the supply of liners adequate? # of liners left: Yellow: ___ Green: ___ Black: ___ Brown: ___ If not, # liners needed: Yellow: ___ Green: ___ Black: ___ Brown: ___	
		Are bins cleaned after collection? If not:	
		Are trolleys cleaned after collection? If not:	
		Is disinfectant used? Type of disinfectant: Concentration of disinfectant:	
		Are the bins in good condition? If not, repairs needed:	
		Are PPEs used? If not:	
		Are the PPEs in good condition? If not, repairs/new equipment needed:	

Annex D 6: Occupational Incident/Accident Report (OIR) Form

Part 1 (NOTE: ALL MEDICAL DATA IS CONFIDENTIAL)

1. Name: _____ Date of Incident/Accident: _____ Time: _____

2. Describe the incident fully

a. Actual task during the incident: _____

b. Area of assignment during the incident: _____

c. Type of Exposure: (tick only the box that apply)

- | | | | |
|---|---|---|--|
| <input type="checkbox"/> Sharp Injury | <input type="checkbox"/> Blood/body fluids | <input type="checkbox"/> Chemicals | <input type="checkbox"/> Others, please specify: |
| <input type="checkbox"/> Needle | <input type="checkbox"/> Splash | <input type="checkbox"/> Splash | |
| <input type="checkbox"/> Surgical Instrument | <input type="checkbox"/> Spillage | <input type="checkbox"/> Spillage | |
| <input type="checkbox"/> Glass | <input type="checkbox"/> Vomitus | <input type="checkbox"/> Others, specify: | |
| <input type="checkbox"/> Other sharp item, specify: | <input type="checkbox"/> Sputum | | |
| | <input type="checkbox"/> Saliva | | |
| | <input type="checkbox"/> Blood/blood products | | |
| | <input type="checkbox"/> CSF | | |
| | <input type="checkbox"/> Pleural Fluids | | |
| | <input type="checkbox"/> Urine | | |
| | <input type="checkbox"/> Feces | | |
| | <input type="checkbox"/> Others, specify: | | |

d. Location of Exposure/Injury of the body part (tick only the box that apply)

- | | | | |
|--------------------------------------|-------------------------------|--------------------------------|---|
| <input type="checkbox"/> Intact Skin | <input type="checkbox"/> Eyes | <input type="checkbox"/> Mouth | <input type="checkbox"/> Others, specify: |
| <input type="checkbox"/> Wound | <input type="checkbox"/> Nose | | |

e. Personal Protective Equipment worn at the time of exposure (tick all the boxes that apply)

- | | | | |
|--|--|--|---|
| <input type="checkbox"/> Gloves, single pair | <input type="checkbox"/> Goggles | <input type="checkbox"/> Disposable gown | <input type="checkbox"/> Others, specify: |
| <input type="checkbox"/> Gloves, double pair | <input type="checkbox"/> Face shield | <input type="checkbox"/> N95 respirator | |
| | <input type="checkbox"/> Surgical mask | <input type="checkbox"/> Lab coat/gown | |

f. Immunization Status:

- | | | | |
|--------------------------------------|--|--|---|
| <input type="checkbox"/> _____ Hep B | <input type="checkbox"/> _____ Tetanus | <input type="checkbox"/> _____ Unknown | <input type="checkbox"/> Others, specify: |
|--------------------------------------|--|--|---|

3. Risk Assessment (tick one only)

- High Risk Exposure (source of exposure from HIV x ans HBV/air-borne diseases)
 Low Risk Exposure (source of exposure from HIV x ans HBV/air-borne diseases)

Corrective actions undertaken: _____

Plans to prevent similar incidents from occurring in the future: _____

4. Referred to Emergency Medical Service/Emergency Room Physician?

- | | |
|------------------------------|---------------|
| <input type="checkbox"/> Yes | Date: _____ |
| <input type="checkbox"/> No | Reason: _____ |

Accomplished by:

Name and Signature: _____ Date: _____

Department/Section: _____

Part 2 (To be filled-up by ICN)

Name of Attending Physician: _____

Advice/Treatment Given: _____













Additional recommendation/suggestions: _____

Note: For HIV exposure, refer to HACT for further evaluation and management.

ANNEX E: Drawings and Illustrations

- Annex E 1: EMB and Other Universally Accepted Hazard Symbols
- Annex E 2: Sample Transport Route Plan
- Annex E 3: Sample Layout of Chemical Storage Room
- Annex E 4: Sample Layout of Waste Storage Area
- Annex E 5: Sample Placard for Off-Site Transport Vehicle
- Annex E 6: Sample Schematic Diagram of Encapsulation
- Annex E 7: Sample Design of Concrete Vault
- Annex E 8: Sample Design of Placenta Pit
- Annex E 9: Sample Design of Safe On-site Waste Burial Pit
- Annex E 10: Schematic Diagram of a Horizontal Reed Bed System for Wastewater System
- Annex E 11: Schematic Diagram of a Natural Pond System for Wastewater Treatment
- Annex E 12: Schematic Diagram of a Sequencing Batch Reactor (SBR) System for Wastewater Treatment

Annex E 1: EMB and Other Universally Accepted Hazard Symbols

 <p>RECYCLABLE SYMBOL</p>	 <p>BIOHAZARD SYMBOL</p>
 <p>OLD RADIATION SYMBOL</p>	 <p>NEW RADIATION SYMBOL / IONIZING RADIATION SIGN</p>
 <p>CYTOTOXIC</p>	 <p>INFECTIOUS SYMBOL</p>
 <p>FLAMMABLE LIQUID</p>	 <p>FLAMMABLE SOLID</p>
 <p>CORROSIVE</p>	 <p>EXPLOSIVE</p>
 <p>REACTIVE</p>	 <p>POISON/TOXIC</p>

Annex E 2: Sample Transport Route Plan

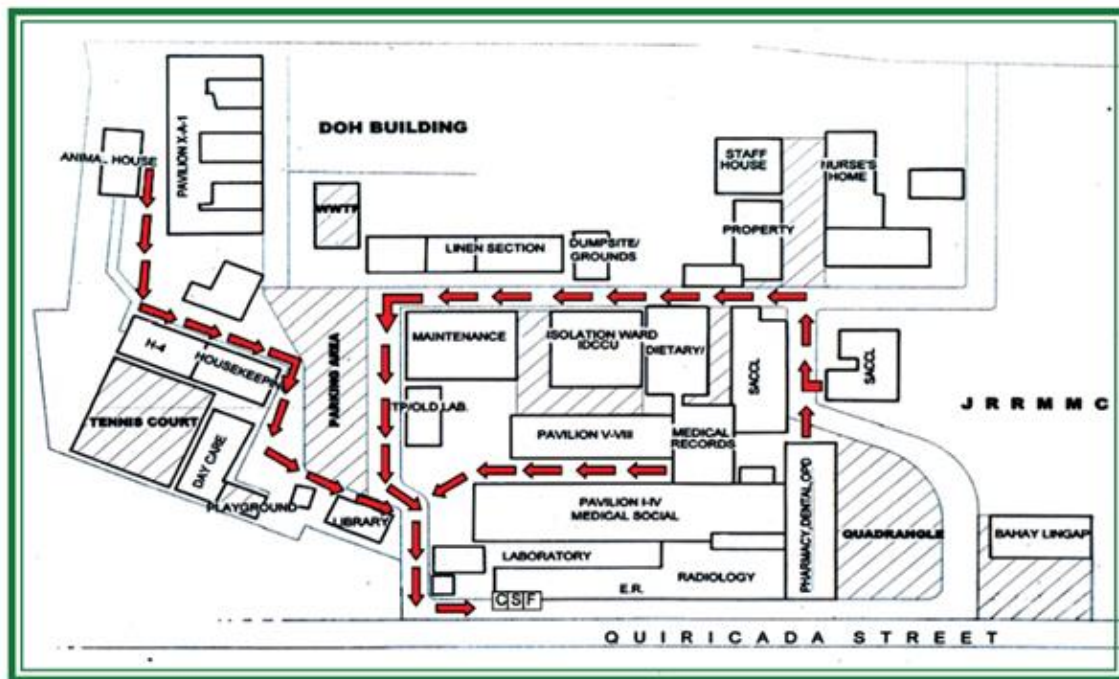

Source: Health Care Waste Management Manual, 3rd Edition (DOH, 2011)

Annex E 3: Sample Layout of Chemical Storage Room

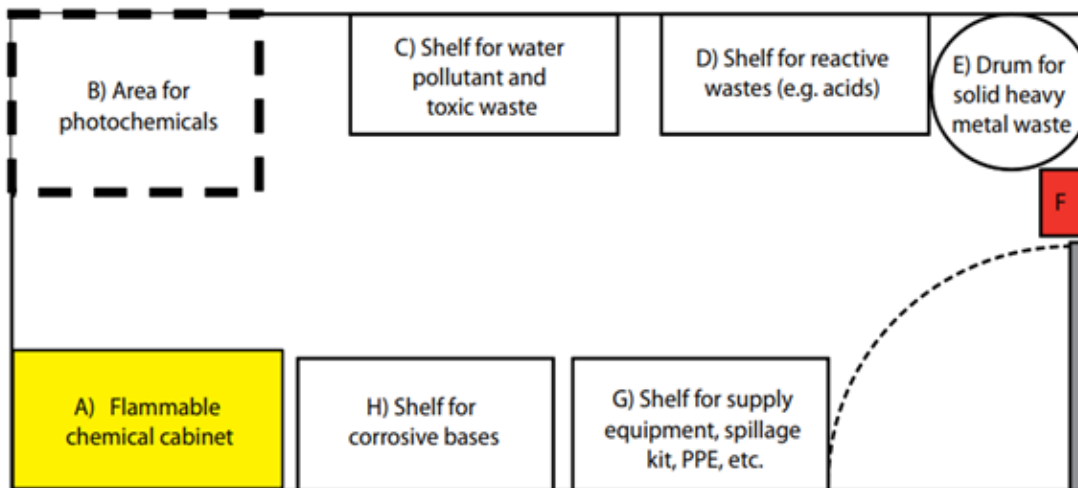

Source: Safe Management of Wastes from Health-Care Activities, 2nd Edition (WHO, 2014)

Annex E 4: Sample Layout of Waste Storage Area

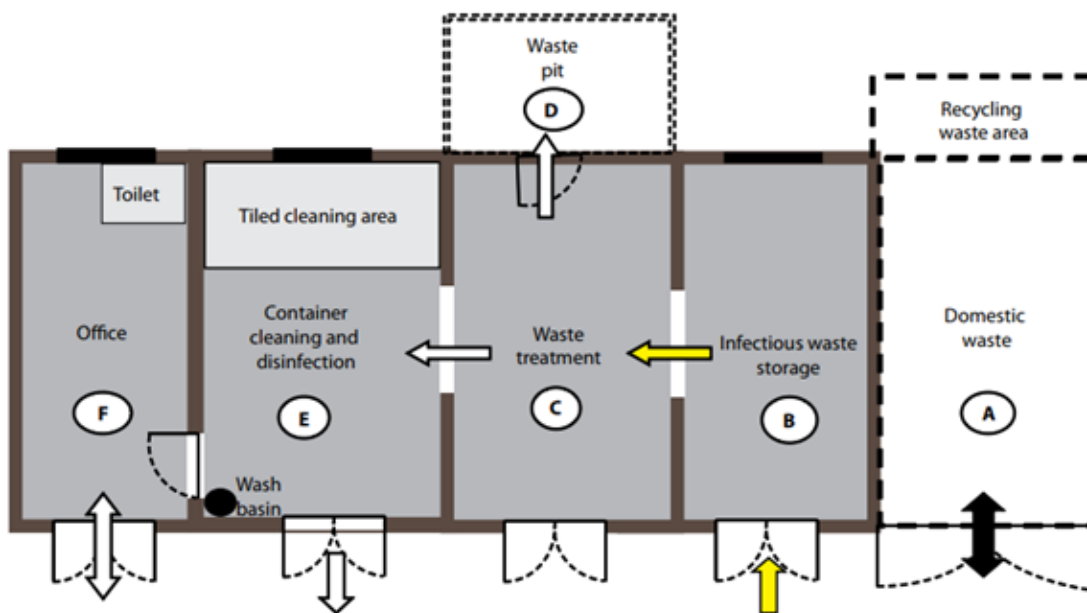

Source: Safe Management of Wastes from Health-Care Activities, 2nd Edition (WHO, 2014)

Annex E 5: Sample Placard for Off-Site Transport Vehicle

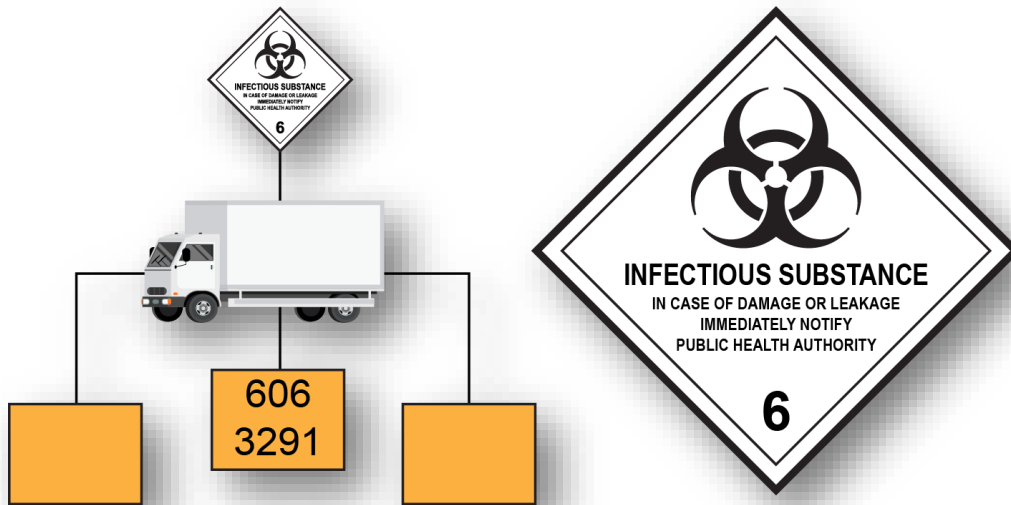

Reference: Safe management of wastes from health-care activities (WHO, 2014)

Annex E 6: Sample Schematic Diagram of Encapsulation

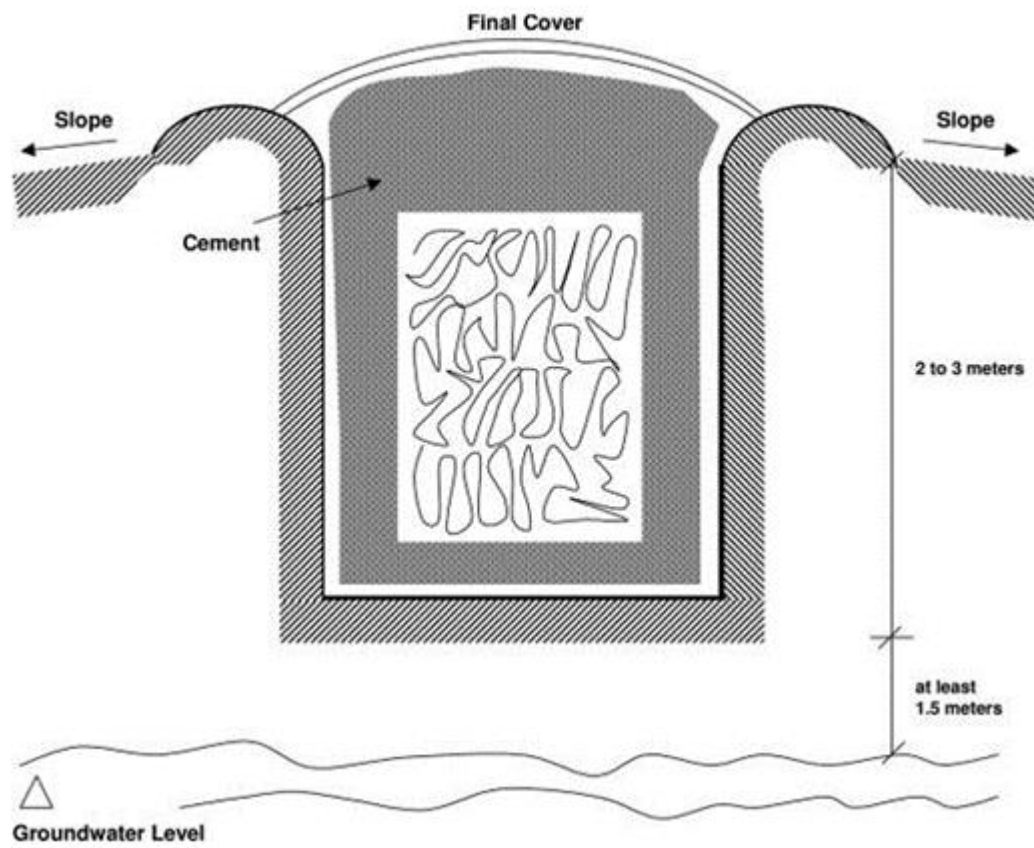

Source: https://www.who.int/water_sanitation_health/facilities/waste/module15.pdf

Annex E 7: Sample Design of Concrete Vault

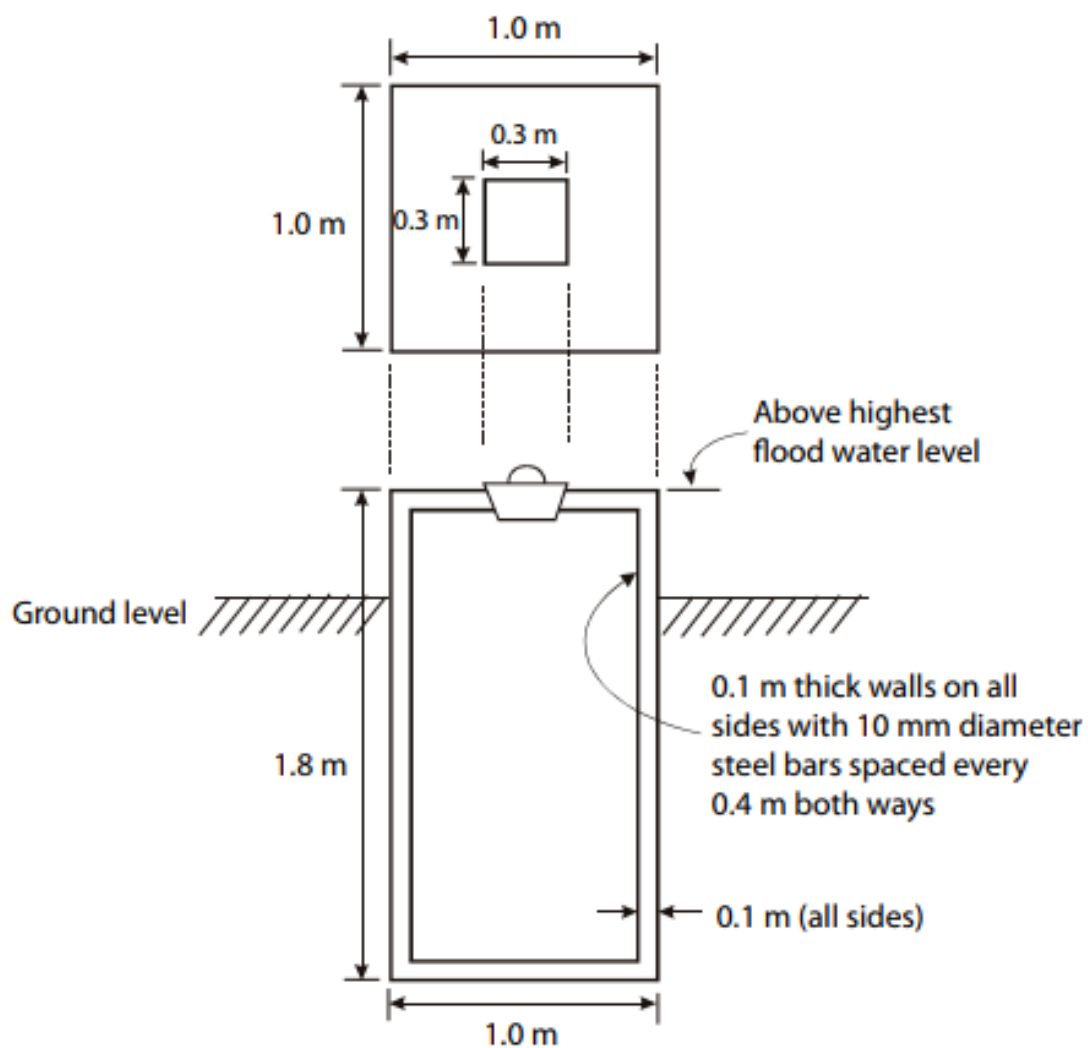

Source: Safe Management of Wastes from Health-Care Activities, 2nd Edition (WHO, 2014)

Annex E 8: Sample Design of Placenta Pit

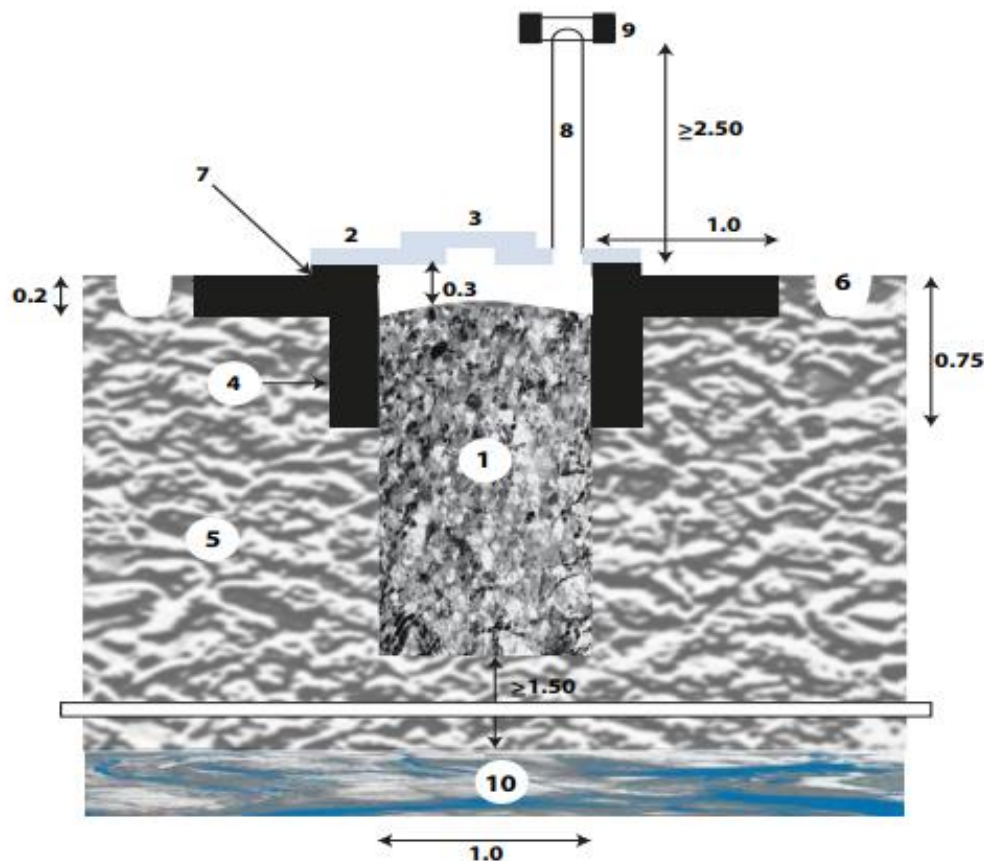

The top 50 cm (or more) of the pit should be reinforced with concrete to prevent surface water infiltration. The base of the pit should be made from concrete to stabilize the structure and to slow the downward movement of liquid towards the water table. Placenta pits can be also constructed from a standard concrete ring with a diameter of about 1 m. The top slab should be above ground level and made from watertight concrete to prevent surface water infiltration. The top should be closed by a lockable hatch and a vent pipe installed to ensure that the generated gases can escape and air can get in. Where soil is particularly sandy, extra precautions may need to be taken to protect the water table and to prevent the pit from collapsing: the sides may be reinforced with bricks, laid with gaps between them so that the liquids can still escape.

1. Pit: string line, sticks and measuring tape
 2. Slab: shovel, hoe, pick axe, miner's bar
 3. Lid: fired bricks or cement blocks
 4. Base or lining: sand, cement, gravel and clean water
 5. Permeable soil: reinforcement bars (diameter 8 mm)
 6. Drainage channel: tools to prepare and cast concrete; masons' tools
 7. Mortar layer (at least 10 mm thick): jute sacking or plastic sheeting
 8. Ventilation pipe: prefabricated slab with lid
 9. Tee with mosquito netting: protective clothing for operators
 10. Water table: polyvinyl chloride (PVC) pipe (preferably diameter 150 mm), piece of stainless steel or nylon mosquito net
- Dimensions are indicated in metres; labour requirements are for an experienced mason and one or two labourers
Source: Médecins Sans Frontières (2010)

Source: Safe Management of Wastes from Health-Care Activities, 2nd Edition (WHO, 2014)

Annex E 9: Sample Design of Safe On-site Waste Burial Pit

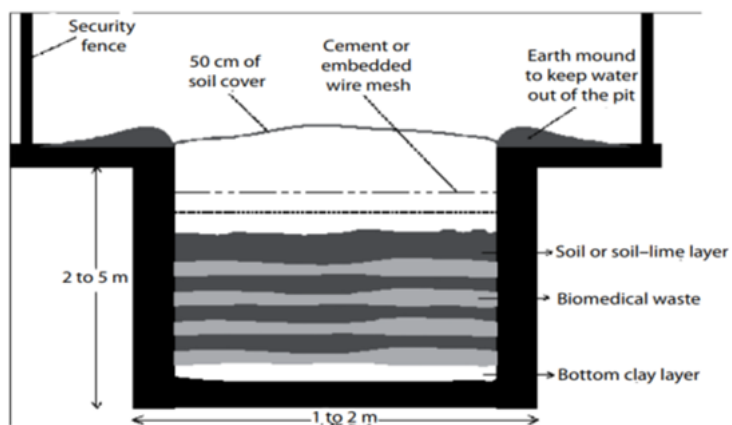
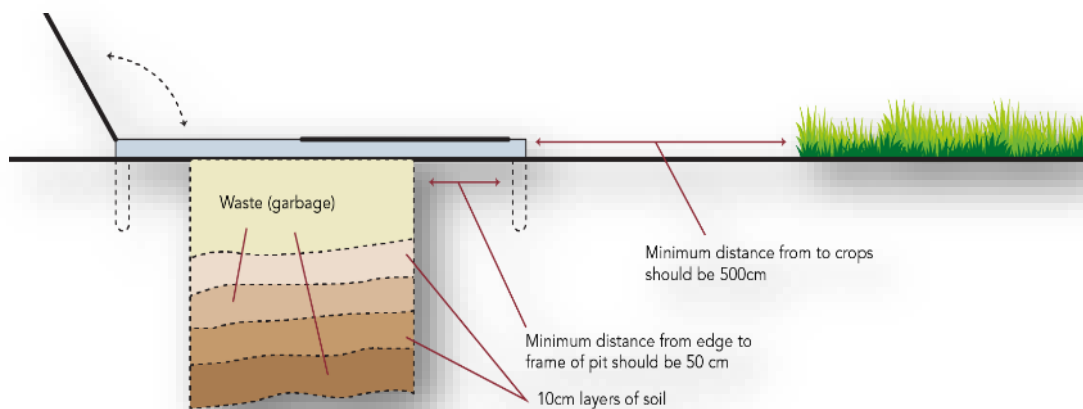
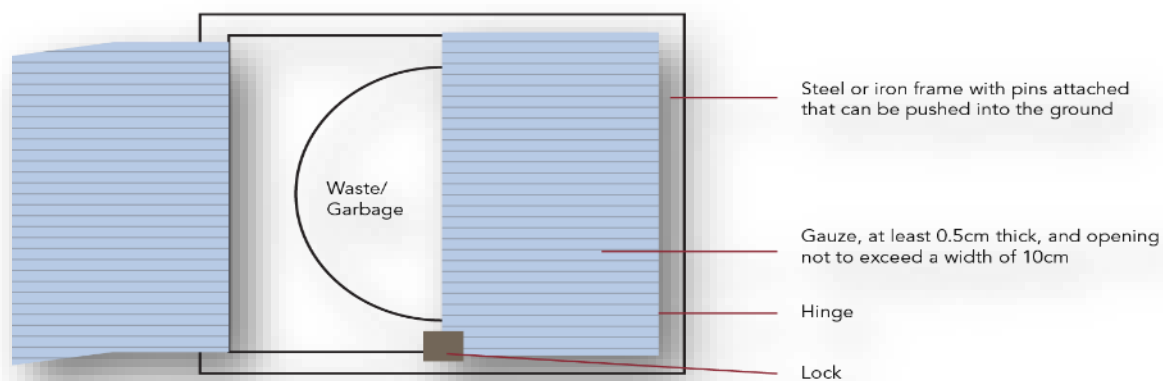

Source: Safe Management of Wastes from Health-Care Activities, 2nd Edition (WHO, 2014)

Annex E 10: Schematic Diagram of a Horizontal Reed Bed System for Wastewater System

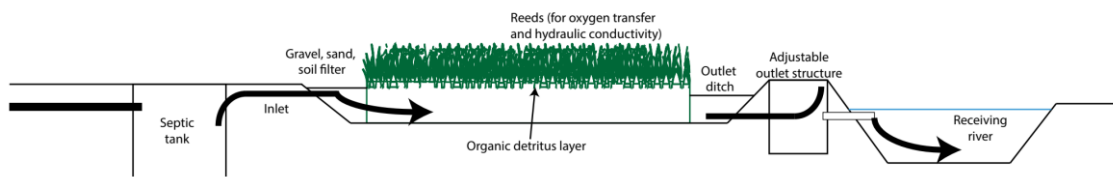

Source: Safe Management of Wastes from Health-Care Activities, 2nd Edition (WHO, 2014)

Annex E 11: Schematic Diagram of a Natural Pond System for Wastewater Treatment

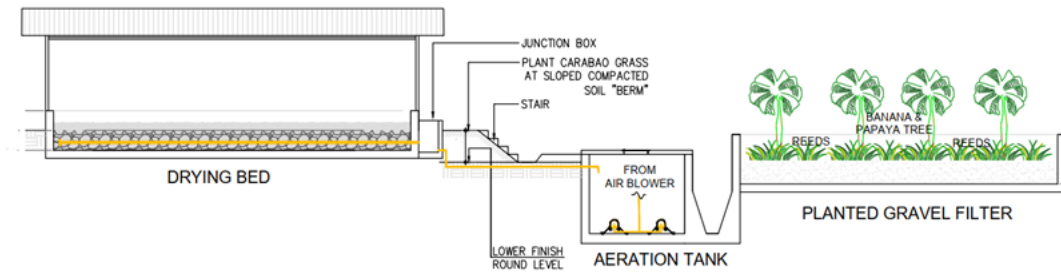

Source: LCI Envi Corporation

Annex E 12: Schematic Diagram of a Sequencing Batch Reactor (SBR) System for Wastewater Treatment

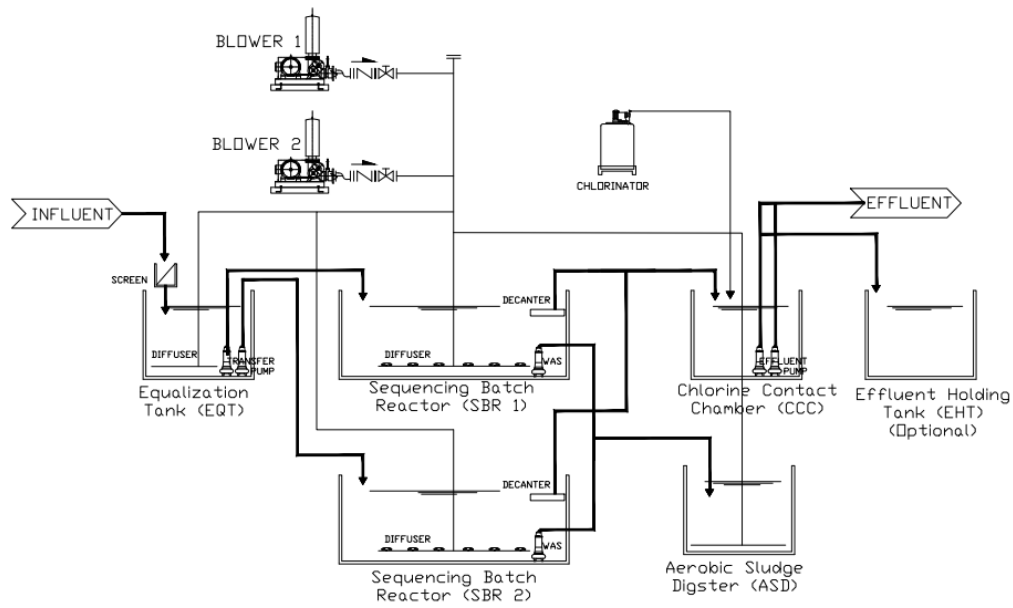

Source: LCI Envi Corporation

ANNEX F: Links

Annex F 1: Online Links to Relevant Legislations, Policies, and Guidelines

Annex F 2: List of Necessary Forms and Reports to be submitted by the HCF

Annex F 1: Online Links to Relevant Legislations, Policies, and Guidelines

Laws/Policies/Guidelines	Links
INTERNATIONAL AGREEMENTS	
The Montreal Protocol on Substances that Deplete the Ozone Layer (1987)	https://unep.ch/ozone/pdf/Montreal-Protocol2000.pdf
The Basel Convention on the Control of Transboundary Movements of Hazardous Wastes and Their Disposal (1989)	https://www.basel.int/Portals/4/Basel%20Convention/docs/text/BaselConventionText-e.pdf
The United Nations Framework Convention on Climate Change (1992)	https://unfccc.int/resource/docs/convkp/conveng.pdf
The Kyoto Protocol to the United Nations Framework Convention on Climate Change (1997)	https://unfccc.int/resource/docs/convkp/kpeng.pdf
The Stockholm Convention on Persistent Organic Pollutants (2001)	https://www.wipo.int/edocs/lexdocs/treaties/en/unep-pop/trt_unep_pop_2.pdf
The Minamata Convention on Mercury (2013)	http://www.mercuryconvention.org/Portals/11/documents/Booklets/COP3-version/Minamata-Convention-booklet-Sep2019-EN.pdf
World Health Assembly Resolution on Water, Sanitation and Hygiene (WASH) in Health Care Facilities (2019)	https://apps.who.int/gb/ebwha/pdf_files/WHA72/A72_R7-en.pdf
NATIONAL LAWS AND POLICIES	
<i>Republic Acts</i>	
Republic Act 4226 "Hospital Licensure Act" (1965)	
Republic Act 6969 "An Act to Control Toxic Substances and Hazardous and Nuclear Wastes (1990)	https://www.officialgazette.gov.ph/1990/10/26/republic-act-no-6969/
Republic Act 8749 "The Philippine Clean Air Act" (1999)	https://emb.gov.ph/wp-content/uploads/2015/09/RA-8749.pdf
Republic Act 9003 "Ecological Solid Waste Management Act" (2000)	https://www.officialgazette.gov.ph/2001/01/26/republic-act-no-9003-s-2001/
Republic Act 9275 "The Philippine Clean Water Act" (2004)	https://www.officialgazette.gov.ph/2004/03/22/republic-act-no-9275/
Republic Act 11223 "Universal Health Care Act" (2018)	https://www.officialgazette.gov.ph/2019/02/20/republic-act-no-11223/
<i>Presidential Decrees</i>	
Presidential Decree 856 "The Code of Sanitation of the Philippines" (1975)	https://www.officialgazette.gov.ph/1975/12/23/presidential-decree-no-856-s-1975/
Presidential Decree 984 "Providing for the Revision of Republic Act 3931, Commonly known as the Pollution Control Law, and for Other Purposes" (1976)	http://r12.emb.gov.ph/wp-content/uploads/2016/04/presidential-decree-no984.pdf
Presidential Decree 1586 "Environmental Impact Statement System" (1978)	https://emb.gov.ph/wp-content/uploads/2015/09/PD-1586.pdf
<i>Executive Orders</i>	
Executive Order 301 "Establishing a Green Procurement Program for all Departments, Bureaus, Offices, and Agencies of the Executive Branch of the Government"	https://www.officialgazette.gov.ph/2004/03/29/executive-order-no-301-s-2004/
<i>DOH Administrative Orders</i>	
Joint DENR-DOH AO No. 2005-02 "Policies and Guidelines on Effective and Proper Handling, Transport, Treatment and Disposal of Health Care Waste"	
DOH AO No. 2007-0014 "Guidelines on the Issuance of Certificate of Product Registration for	

Equipment or Devices Used for Treating Sharps, Pathological and Infectious Waste"	
DOH AO No. 2007-0027 "Revised Rules and Regulations Governing the Licensure and Regulation of Clinical Laboratories in the Philippines"	http://lcp.gov.ph/images/Admin_Order_2007_0027.pdf
DOH AO No. 2008-0021 "Gradual Phase-Out of Mercury in All Philippine Health Care Facilities and Institutions"	https://ww2.fda.gov.ph/index.php/issuances-2/others-laws-and-regulations-not-applicable-to-the-above-categories/others-administrative-order/15780-ao2008-21
DOH AO No. 2008-23 "National Policy on Patient Safety"	
DOH AO No. 2010-0033 "Revised Implementing Rules and Regulations of PD 856 Code on Sanitation of the Philippines"	
DOH AO No. 2012-012 "Rules and Regulations Governing the New Classification of Hospitals and Other Health Facilities in the Philippines"	https://hfsrb.doh.gov.ph/wp-content/uploads/2019/07/ao2012-0012-1.pdf
DOH AO No. 2019-0047 "National Standard on the Design, Construction, Operation and Maintenance of Septic Tank Systems"	https://www.scribd.com/document/434777656/DOH-AO-2019-0047-National-Standard-on-the-Design-Construction-Operation-and-Maintenance-of-a-Septic-Tank-System
DENR Administrative Order	
DENR AO No. 2001-34 "Implementing Rules and Regulations of Republic Act 9003"	
DENR AO No. 2006-10 "Guidelines on the Categorized Final Disposal Facilities (Sanitary Landfills)"	https://server2.denr.gov.ph/uploads/rmdd/dao-2006-010_706.pdf
DENR AO No. 2013-22 "Revised Procedures and Standards for the Management of Hazardous Wastes (Revising DAO 2006-036)"	https://server2.denr.gov.ph/uploads/rmdd/dao-2013-22.pdf
DENR AO No. 2014-02 "Revised Guidelines for Pollution Control Officer Accreditation"	https://server2.denr.gov.ph/uploads/rmdd/dao-2014-02.pdf
DENR AO No. 2016-08 "Water Quality Guidelines and General Effluent Standards of 2016"	https://server2.denr.gov.ph/uploads/rmdd/dao-2016-08.pdf
OTHER RELEVANT ISSUANCES AND GUIDELINES	
BFAD Circular No. 16 series of 1999 "Amending BFAD MC #22 dated September 8, 1994 regarding Inventory, Proper Disposal and/or Destruction of Used Vials or Bottles"	https://ww2.fda.gov.ph/attachments/article/17106/bc%2016%20s%201999.pdf
Bench book on performance improvement of health services (Philippine Health Insurance Corporation, 2004)	https://www.philhealth.gov.ph/partners/providers/benchbook/QualityAssuranceProgram_Benchbook.pdf
Operations Manual on the Rules and Regulations Governing Domestic Sludge and Septage (Department of Health, 2008)	http://open_jicareport.jica.go.jp/pdf/11948882_24.pdf
Health Care Waste Management Manual – 3 rd edition (Department of Health, 2011)	
Safe management of wastes from health-care activities, 2 nd edition (World Health Organization, 2014)	https://apps.who.int/iris/bitstream/handle/10665/85349/9789241548564_eng.pdf?sequence=1
Water and Sanitation for Health Facility Improvement Tool (WASH FIT) (World Health Organization, 2018)	https://apps.who.int/iris/bitstream/handle/10665/254910/9789241511698-eng.pdf?sequence=1
Overview of technologies for the treatment of infectious and sharp waste from health care facilities (World Health Organization, 2019)	https://apps.who.int/iris/bitstream/handle/10665/328146/9789241516228-eng.pdf?ua=1

Annex F 2: List of Necessary Forms and Reports to be submitted by the HCF

Forms and Reports Needed	Links
Environmental Compliance Certificate (ECC)	eia.emb.gov.ph
EMB Quarterly Self-Monitoring Report	Please refer to the website of your respective regional DENR-EMB office.
LLDA Clearance	http://llda.gov.ph/llda-clearance/
LLDA Discharge Permit	http://llda.gov.ph/discharge-permit-dp-new/ http://llda.gov.ph/discharge-permit-dp-renewal/
LLDA Self-Monitoring Report	http://llda.gov.ph/wp-content/uploads/dox/forms/smr/frm_smr.pdf
Hazardous Waste Generator Registration Form	https://emb.gov.ph/wp-content/uploads/2018/09/Form_Generator_ver2018.pdf
Hazardous Waste Transporter Registration Form	https://emb.gov.ph/wp-content/uploads/2018/09/Form_Generator_ver2018.pdf
Hazardous Waste Treater Registration Form	https://emb.gov.ph/wp-content/uploads/2018/09/Form_TSD_ver2018.pdf
Hazardous Waste Generator Quarterly/ Annual Report Form	Please refer to the website of your respective regional DENR-EMB office.
Hazardous Waste Transporter Checklist	https://emb.gov.ph/wp-content/uploads/2018/09/checklist_Generator2018.pdf
Hazardous Waste Treater Checklist	https://emb.gov.ph/wp-content/uploads/2018/06/checklist_TSD2018.pdf
Hazardous Waste Transporter Affidavit	https://emb.gov.ph/wp-content/uploads/2018/06/affidavit_HWtransporter.pdf
Hazardous Waste Treater Affidavit	https://emb.gov.ph/wp-content/uploads/2018/06/affidavit_TSDFacility.pdf
Source: Health Care Waste Management Manual, 3rd Edition (DOH, 2011)	

References

- AEA Technology, "Metro Manila Solid Waste Management Project Final Report" ADB, September 2003
- American Society for Hospital Engineering: "Safety Policies and Procedures for Health Care Facilities" by John S. Klare, 1992
- Asian Institute of Technology: "Healthcare Waste in Asia: Intuitions and Insights", 2008
- Basel Convention on the Control of the Trans-boundary Movements of Hazardous Wastes and Their Disposal (1989)
- BFAD Memorandum Circular No. 22 Series of 1994, "Inventory, Proper Disposal and/or Destruction of Used Vials or Bottles" and BFAD Bureau Circular No. 16 Series of 1999: "Amending BFAD MC No. 22 dated September 8, 1994, Regarding Inventory, Proper Disposal and/or Destruction of Used Vials or Bottles"
- Center for Disease Control and Prevention: "Handwashing: Clean Hands Save Lives" <http://www.cdc.gov/handwashing/>
- DENR Administrative Order No. 34, Series 1990 – "Revised Water Usage and Classification/ Water Quality Criteria Amending Section Nos. 68 and 69, Chapter III of the 1978 NPCC Rules and Regulations"
- DENR Administrative Order No. 35, Series 1990, "Effluent Regulations"
- DENR Administrative Order No. 36, Series 2004, "Revising DENR Administrative Order No. 29, Series 1992, to Further Strengthen the Implementation of Republic Act 6969 and Prescribing the Use of the Procedural Manual"
- DOH-DENR Joint Administrative Order No. 02 series of 2005 dated August 24, 2005 "Policies and Guidelines on effective and Proper Handling, Collection, Transport, Treatment, Storage, and Disposal of HCW"
- DOH Administrative Order No. 70-A series of 2002 "Revised Rules and Regulations Governing the Registration, Licensure, and Operation of Hospitals and Other Health Facilities in the Philippines"
- DOH Administrative Order No. 2005-0029 dated December 12, 2005, "Amendment to Administrative Order No. 70-A series of 2002 re: Revised Rules and Regulations Governing the Registration, Licensure and Operation of Hospitals and Other Health Facilities in the Philippines"
- DOH Administrative Order No. 2007-0014, "Guidelines on the Issuance of Certificate of Product Registration for Equipment or Devices Used for Treating Sharps, Pathological and Infectious Waste"
- DOH Administrative Order No. 2007-0027 dated August 22, 2007 "Revised Rules and Regulations Governing the Licensure and Regulation of Clinical Laboratories in the Philippines"
- DOH Administrative Order No. 2008-0021 dated July 30, 2008, "Gradual Phase out of Mercury in all Philippine Health Care Facilities and Institutions"
- DOH Administrative Order No. 2008-0023 dated July 30, 2008, "National Policy on Patient Safety"
- DOH Administrative Order 2010-0033 "Revised Implementing Rules and Regulations of PD 856 Code on Sanitation of the Philippines Chapter XXI Disposal of Dead Persons" December 2010
- DOH Department Memorandum 2011-0145, "Guidelines for the Temporary Storage of Mercury Wastes in Health Care Facilities in Accordance with AO No. 0021 s. 2008 on the Gradual Phase-out of Mercury in All Philippine Health Care Facilities and Institutions"
- DOH "Health Care Waste Management Manual" in 2004 (Revising the 1997 Hospital Waste Management Manual)
- DOH: Operation Manual on the Rules and Regulations Governing Domestic Sludge and Septage, June 2008
- Executive Order No. 301 (2004) "Establishing a Green Procurement Program for All Departments, Bureaus, Offices, and Agencies of the Executive Branch of Government"
- ISO 14001 Environmental Management Guide
- Kyoto Protocol to the United Nations Framework Convention on Climate Change (1997)
- McCay, P.H., Ocampo-Sosa, A.A. & Fleming, G.T.A. (2010). Effect of subinhibitory concentrations of benzalkonium chloride on the competitiveness of *Pseudomonas aeruginosa* grown in continuous culture. *Microbiology* 156: 30-38
- Montreal Protocol on Substances that Deplete the Ozone Layer (1987)
- PNRI Administrative Order 1990-0001: Radioactive Wastes by Philippine Nuclear Research Institute (PNRI) from Off-Site Waste Generators
- PhilHealth Benchbook for Quality Assurance in Health Care (2006)
- Presidential Decree 813 (1975) and Executive Order 927 (1983). "Strengthening the Functions of LLDA"
- Presidential Decree 856 "The Code on Sanitation of the Philippines" (1975)
- Presidential Decree No. 984 "Providing for the Revision of Republic Act No. 3931, Commonly Known

- as the Pollution Control Law, and for Other Purposes" (1976)
- Presidential Decree No. 1586 "Environmental Impact Statement (EIS) System" (1978)
- Republic Act No. 4226 "Hospital Licensure Act" (1965)
- Republic Act No. 6969 - "An Act to Control Toxic Substances and Hazardous and Nuclear Wastes" (1990)
- Republic Act No. 8749 - "The Philippine Clean Air Act of 1999"
- Republic Act No. 9003 - "Ecological Solid Waste Management Act of 2000"
- Republic Act No. 9275 - "The Philippine Clean Water Act of 2004"
- Sanez, Geri Geronimo: "Health Care Waste Management in the Philippines", for the Thematic Working Group on Solid and Hazardous Wastes, 2008
- Scientific Applications International Corporation: "Life Cycle Assessment: Principles and Practice", 2006
- Stockholm Convention on Persistent Organic Pollutants (2001)
- UN: "Globally Harmonized System of Classification and Labeling of Chemicals (GHS)" Third Revised Edition, 2009
- United Nations Framework Convention on Climate Change (1997)
- WB Water and Sanitation Program: "Philippine Sanitation Sourcebook and Decision Aid", 2005
- WHO: Safe Management of Wastes from Health Care Activities, 1999
- WHO: Safe Management of Wastes from Health Care Activities, draft second edition
- WHO: Practical Guidelines for Infection Control in Health Care Facilities, 2004
- WHO: Laboratory Safety Manual, Third Edition, 2004
- WHO: Guidance Manual for the Preparation of National Health Care Waste Management Plans in Sub-Saharan Countries
- WHO: Guidelines for the Safe Use of Wastewater, Excreta, and Greywater, Volume II, Wastewater Use in Agriculture, 2006
- WHO Guidelines on Hand Hygiene in Health Care, 2009
- WHO: http://www.who.int/gpsc/5may/How_To_HandWash_Poster.pdf
- WHO: http://www.who.int/gpsc/5may/How_To_HandRub_Poster.pdf
- WHO: "Risks and Costs Associated with the Management of Infectious Wastes" by L.F. Diaz and G.M. Savage, 2003
- WHO: Philippines: Environmental Health and Country Profile, 2005



Health Care Waste Management Manual
Fourth Edition
2020