

Introduction to Low Cost Sanitation

Planning, Promotion, Design & Construction





12, 2916 – 5th Avenue
Calgary, Alberta, T2A 6K4, Canada
Phone: + 1 (403) 243-3285, Fax: + 1 (403) 243-6199
E-mail: cawst@cawst.org, Website: www.cawst.org

CAWST is a Canadian non-profit organization focused on the principle that clean water changes lives. Safe water and basic sanitation are fundamentals necessary to empower the world's poorest people and break the cycle of poverty. CAWST believes that the place to start is to teach people the skills they need to have safe water in their homes.

CAWST transfers knowledge and skills to organizations and individuals in developing countries through education, training and consulting services. This ever expanding network can motivate individual households to take action to meet their own water and sanitation needs.

One of CAWST's core strategies is to make knowledge about water common knowledge. This is achieved, in part, by developing and freely distributing education materials with the intent of increasing its availability to those who need it most. You should feel free to copy and distribute this document in any form, printed or electronic. If you wish to use any parts of this document in the creation of your own materials, please ensure that CAWST is properly acknowledged. Please include our website address: www.cawst.org.

Feel free to include a link from your website to the CAWST website. Please do not host this document to download from your website as we will have updated versions from time to time. Please email us if you have any questions or feedback.

This document is open content and licensed under the Creative Commons Attribution Works 3.0 Unported License. To view a copy of this license, visit: <http://creativecommons.org/licenses/by/3.0>

You are free to:

- Share – to copy, distribute and transmit this document
- Remix – to adapt this document

Under the following conditions:

- Attribution. You must give credit to CAWST as the original source of the document

CAWST and its directors, employees, contractors, and volunteers do not assume any responsibility for and make no warranty with respect to the results that may be obtained from the use of the information provided.

Table of Contents

1	Introduction to Low Cost Sanitation	1
1.1	The Need for Sanitation	1
1.2	What is Sanitation?.....	3
1.3	Contributing to the Millennium Development Goals.....	3
1.4	Improving Sanitation	6
1.5	Health Impacts.....	9
1.5.1	Pathogenic Bacteria.....	10
1.5.2	Pathogenic Viruses	10
1.5.3	Pathogenic Protozoa.....	10
1.5.4	Pathogenic Helminths	11
1.6	Non-Health Impacts	12
2	Promoting and Implementing Sanitation Projects	15
2.1	Behaviour Change	15
2.1.1	Why Do People Act As They Do?	16
2.1.2	Factors That Influence People to Change.....	19
2.1.3	Helping People to Change	21
2.2	Choosing a Promotion Method.....	23
2.3	Promotion Methods.....	24
2.3.1	Awareness and Education	24
2.3.2	Health Education and Subsidies	26
2.3.3	Incentive Based Sanitation.....	27
2.3.4	Integrated / Holistic Approaches	27
2.3.5	PHAST.....	28
2.3.6	Social Marketing	29
2.3.7	Community Led Total Sanitation	35
2.3.8	Water and Sanitation Users Group	40
2.3.9	Schools and Youth Clubs.....	40
3	Selection of Appropriate Sanitation Options	42
3.1	Social and Cultural Factors	42
3.2	Physical, Environmental and Technical Factors	46
3.2.1	Space Availability	46
3.2.2	Soil and Groundwater Conditions.....	47
3.2.3	Water Availability	50
3.2.4	Local Availability of Materials	50
3.2.5	Structure Design	51
3.3	Stakeholders.....	53
4	Latrine Design, Construction and Maintenance Guidelines.....	55
4.1	Common Elements	55
4.1.1	Pits.....	55
4.1.2	Slabs.....	56
4.1.3	Hole Covers	56
4.1.4	Superstructure	57
4.2	Maintenance	57
4.3	Safe Emptying of Latrines.....	57
4.4	Designing for Children and Schools.....	60
4.5	Designing for Special Needs Users	63
4.6	Feminine Hygiene Considerations	64
4.7	Further Information	67
5	Excreta Management Options	69

5.1	Open Defecation.....	69
5.1.1	Cat Scrape Latrine.....	69
5.1.2	Bucket Latrine/Nightsoil Collection.....	70
5.2	Pit Latrine Options.....	70
5.2.1	Simple Pit Latrine.....	71
5.2.2	Ventilated Improved Pit Latrine.....	71
5.2.3	Pour Flush Pit Latrine.....	72
5.2.4	Twin-Pit Latrines.....	72
5.3	Ecological Sanitation for Excreta Disposal.....	73
5.3.1	Composting Latrine (Without Urine Diversion).....	77
5.3.2	Dehydrating Latrine (With Urine Diversion).....	78
5.3.3	Arborloo.....	80
5.3.4	Biogas Digester.....	80
5.4	Tank Options for Excreta Disposal.....	81
5.4.1	Aqua Privy.....	81
5.4.2	Septic Tank.....	81
5.4.3	Cess Pit.....	82
5.5	Low-Cost, Small Bore, Settled Sewage Systems.....	82
5.6	Further Information.....	83
6	Excreta Disposal in Difficult Conditions.....	85
6.1	Areas with Difficult Conditions Due to Water.....	85
6.1.1	Solutions for Areas with Difficult Conditions Due to Water.....	86
6.2	Rocky ground (Difficult Excavation).....	89
6.3	Space Limitations.....	89
6.3.1	Solutions for Areas with Space Limitations.....	89
6.4	Cold Climate.....	90
7	Domestic Wastewater Reuse and Disposal.....	93
7.1	Grease Traps.....	94
7.1.1	Grease Trap Designs.....	95
7.1.2	Determining the Size of a Grease Trap.....	97
7.1.3	Construction.....	97
7.1.4	Maintenance.....	97
7.2	Soak Pits.....	98
7.3	Surface Water Drainage.....	100
8	Improved Hygiene.....	101
8.1	Hand Washing Facilities.....	103
8.1.1	Hand Washing Wastewater Disposal.....	103
8.1.2	Soap and Ash.....	104
9	Solid Waste Management.....	105
9.1	Generation and Collection.....	106
9.2	Processing.....	107
9.2.1	Recycling.....	107
9.2.2	Compost.....	107
9.2.3	Burning.....	109
9.3	Disposal.....	109
9.4	Hazardous Waste.....	110
9.5	Solid Waste Attitudes.....	111
9.6	Further Information.....	111
10	Vector Control.....	113
10.1	Mosquito Control.....	113

10.1.1	Mosquito Disease Transmission.....	115
10.1.2	Control Strategies	116
10.2	Flies.....	119
10.3	Rodents	120
10.3.1	Passive Control Measures	120
10.3.2	Active Control Measures	121
11	Review Activities.....	125
11.1	Shtole Case Study	127
11.1.1	Shtole Case Study – Solutions	130
11.2	Kashgar, Xinjiang, China Case Study	131
11.2.1	Kashgar, Xinjiang, China Case Study – Solutions.....	133
11.3	Urbanizacao, Maputo, Mozambique Case Study	135
11.3.1	Urbanizacao, Maputo, Mozambique Case Study – Solutions	137
11.4	Tal Camp, Bangladesh Case Study	139
11.4.1	Tal Camp, Bangladesh Case Study – Solutions.....	142
12	References.....	145

Appendix 1: Latrine Fact Sheets

Appendix 2: Design Calculations for Latrine Pits

Appendix 3: Design Calculations for Soak Pits and Infiltration Trenches

Glossary

The following website is an online water and sanitation thesaurus compiled by IRC and partners in 2008: www.thesaurus.watsan.net/en/index.html.

Bacteria

Very small single-celled organisms that are present everywhere and are the most common microorganism found in human and animal feces. Drinking water that contains feces is the main cause of water-related diseases. The most common water-related diseases caused by pathogenic bacteria have diarrhea as a major symptom, including cholera, shigellosis (also known as bacillary dysentery) and typhoid.

Black water

Wastewater that has been used to flush a toilet or latrine that contains excreta. Also called sewage. This contains a large amount of pathogens.

Clarification

The process used to settle out suspended solids in wastewater using gravity.

Community Led Total Sanitation (CLTS)

A method to encourage improved sanitation within a community. Emphasis is put on facilitating increased awareness of the current sanitation condition in the community and the associated impacts on health and well-being; and generating a sense of disgust resulting from open defecation. This is intended to lead to self-mobilization of the community to stop open defecation and to improve their sanitation facilities by building and using latrines.

Defecation

How a person relieves themselves and where feces are deposited, whether in the open (e.g. in a field, bush) or using a latrine.

Diarrheal Diseases

A disease that affects the intestines by producing watery stools, including cholera, typhoid and shigellosis. The victims of these diseases, frequently children in low- and middle-income countries, may die from dehydration. Dehydration is prevented by orally rehydrating with fluids and rehydration salts or solutions.

***E. coli* (*Escherichia coli*)**

E. coli is the most important indicator used in drinking water quality testing and has been used for over 50 years. It is a coliform bacteria found predominantly in the feces of warm-blooded animals. The majority of *E. coli* is harmless; however there are some strains (such as O157:H7) that are known to cause severe diarrhea and other symptoms.

Environmental Sanitation

Combined management of: excreta, wastewater, household solid waste and drainage of storm water.

Excreta

Urine and feces.

Feces

Solid human waste from defecation. Also called poop, poo, or shit.

Grey water

All other types of wastewater from domestic activities (e.g. laundry, dish washing, bathing, cleaning). This contains some pathogens..

Hardware

Infrastructure, technology, construction materials and physical products (e.g. pipe, latrine slab, septic tank, water tank, pumps, filters).

Helminth

Pathogenic worms that are generally passed through human and animal feces. Some spend part of their life in hosts that live in water before being passed on to people through the skin. For others, the infection route is by ingestion or by vectors such as mosquitoes. Common types of pathogenic helminths that cause illness are round worms, pin worms, hook worms and guinea worms. Schistosomiasis, also known as bilharzia, is caused by the trematode flatworm.

Hygiene

Practices, such as frequent hand washing, that help ensure cleanliness and good health.

Hygienic Latrine

A latrine that eliminates any contact between humans and feces, where no feces are present around/on the floor or seat, and there are few or no flies (IRC, 2004; Billig, 1999).

Impact

The extent to which a program or project has made a long-term change.

Improved Sanitation

Hygienically separates human excreta from human contact, and includes the following latrine types: pit latrine with slab; ventilated improved pit (VIP) latrine; composting toilet; flush or pour-flush discharging to pit latrine, septic tank, piped sewer system (WHO/UNICEF JMP, 2010).

Implementation

Implementation is a phase in the project cycle which takes place after planning. It is the process of putting all project functions and activities into place to reach a specific goal.

Infectious Disease

A disease that can be passed from one person to another.

Infiltration

The process by which water on the ground surface enters the soil. Infiltration rate is a measure of the rate at which soil is able to absorb water. It is measured in millimetres per hour. The infiltration rate decreases as the soil becomes saturated.

Input

The financial, human, and material resources required for the operation and implementation of the project.

Microorganism

Organisms that are too small to be seen with the naked eye, such as bacteria, viruses and protozoa. Also called microbe, germ, bug, or pathogen (disease-causing microorganism).

Open Defecation

The practice of defecating in a field, a forest, behind a tree, in the street, in a water body (lake, pond or river), in an open drain or out in the open; not using a latrine or covered pit.

Oral Rehydration Therapy (ORT)

A simple, cost-effective treatment for diarrheal dehydration that can be given at home using either packets of Oral Rehydration Salts (ORS) or a simple solution of sugar, salt and water. ORT has saved millions of children's lives.

Outcomes

The medium-term results of the activities.

Outputs

The short-term achievement of the activities.

Pathogens

Disease causing organisms.

Protozoa

Single celled organisms that are larger than bacteria and viruses. Some protozoa are parasites that need a living host to survive. They weaken the host by using up their food and energy, damaging their internal organs or causing immune reactions. Amoeba, cryptosporidium and giardia are some of the pathogenic protozoa found in water. Malaria is a protozoa that is passed on by mosquitoes.

Safe Water

Safe water does not have any detectable fecal contamination in any 100 ml sample and meets the WHO Guidelines for Drinking Water Quality (2006).

Sanitation

Generally refers to the provision of facilities and services, such as latrines, for the safe disposal of human urine and feces. Also refers to wastewater disposal, garbage collection and disposal and insect/rodent control.

Sanitation Demand

The motivators behind and barriers against people constructing their own latrines. Each household and community may have different needs, knowledge, attitudes and beliefs that influence their decision to construct or not construct a toilet at home.

Understanding the demand for sanitation means learning what the perceived motivators and barriers are to constructing toilets at the household and community levels. *Creating* or increasing sanitation demand in a community refers to creating conditions such that more people choose to construct toilets, i.e., creating sufficient motivators or removing barriers (or providing alternatives) so that constructing toilets becomes attractive to people.

Sanitation Facilities

Buildings and other infrastructure that allow people to practice improved sanitation. Generally refers to latrines, sewer systems and hand washing stations, but may also include bath/washing areas, dish washing stations, wastewater collection and infiltration/treatment systems and solid waste disposal pits.

Sewage

A suspension of liquid and solid waste, largely comprised of water and excreta, transported by sewer pipes or channels for treatment or disposal.

Soak Pit

Dug pit that allows wastewater to be safely infiltrated into the ground.

Software

Training, education, awareness, skills. Includes projects designed to transfer such knowledge, curriculum and teaching materials.

Stakeholders

Groups or individuals with different levels of knowledge, influence, activity and roles within a community with respect to sanitation. Have the potential to affect or are affected by the sanitation situation in a community.

Unimproved Sanitation

Defecation systems that do not eliminate contact between feces and humans and/or the open environment, thereby not protecting human and environmental health. Unimproved sanitation systems include: open defecation; public facilities (largely because they are often poorly maintained and unhygienic); hanging latrines; bucket latrines; pit latrines without a slab or with open pits; and pour-flush/flush latrines that discharge to a street, open drain, waterway or other open area (WHO & UNICEF, 2008).

Vectors

An insect or any living carrier that transmits an infectious disease. Common vectors include mosquitoes, flies, ticks, rats, and mice.

Water-Borne Diseases

Diseases spread through drinking contaminated water.

Water-Insect-Vector Diseases

Diseases passed on by insects that breed or live in water, such as mosquitoes.

Wastewater

Water that has been used by some human activity (e.g. hand washing, bathing, dish washing, food washing, household cleaning) and contains waste products.

Wastewater Treatment

Physical, chemical, and biological processes used to remove contaminants from waste water before discharging it into source water.

Acronyms

CAWST	Centre for Affordable Water and Sanitation Technology
CLTS	Community Led Total Sanitation
HWT	household water treatment
INGO	international non-governmental organization
IRS	indoor residual spraying
MDG	Millennium Development Goals
NGO	non-governmental organization
Nd	no date
O&M	operation and maintenance
ORS	oral rehydration salts
ORT	oral rehydration therapy
SLTS	School Led Total Sanitation
UN	United Nations
UK	United Kingdom
UV	ultra violet
UNDP	United Nations Development Program
UNICEF	United Nations Children's Fund
VIP	ventilated improved pit latrine
WASH	water, sanitation and hygiene
WatSan	water and sanitation
WEDC	Water Engineering and Development Centre, UK
WHO	World Health Organization
WSUG	Water and Sanitation Users Group

1 Introduction to Low Cost Sanitation

1.1 The Need for Sanitation

Access to safe drinking water is a fundamental human need and human right for every man, woman and child. People need clean water to maintain their personal health and dignity.

Health can be compromised when pathogens--microorganisms that cause disease such as bacteria, viruses, protozoa and helminths--contaminate drinking water. The majority of the microorganisms that contaminate drinking water come from human feces. One gram of feces may contain 10 million viruses, one million bacteria, 1000 protozoan cysts and 100 worm eggs (WHO/UNICEF JMP, 2010).

Leading Causes of Deaths from Infectious Diseases

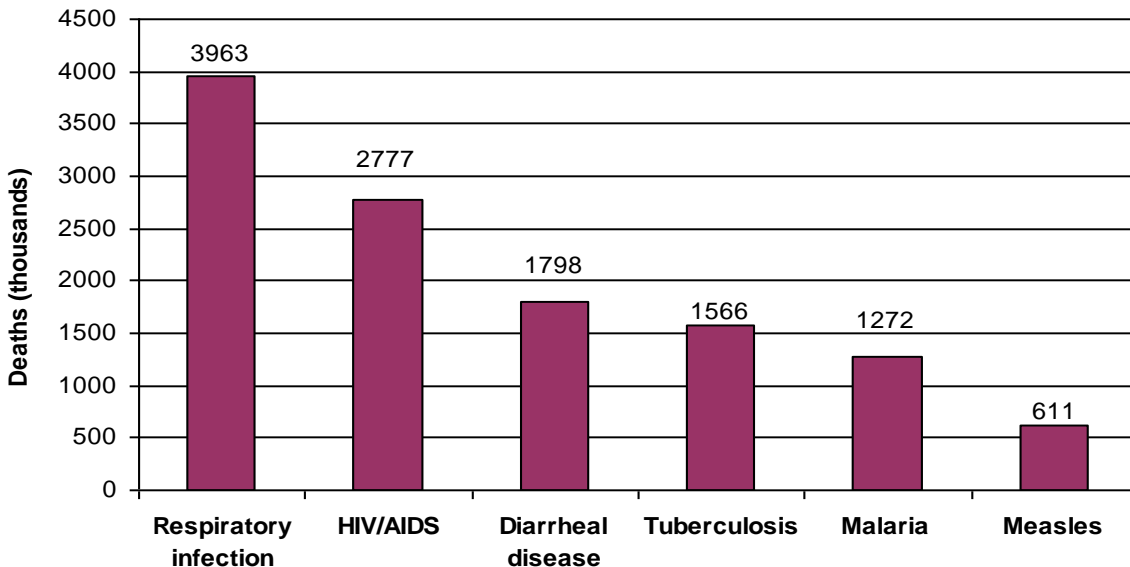

(WHO, 2004)

Around 2.6 billion people lack access to adequate sanitation globally (WHO/UNICEF JMP, 2010). Inadequate access to sanitation facilities forces people to defecate in the open, thus increasing the risk of transmitting disease through fecal contamination. At any given time close to half the people in the developing world are suffering from one or more of the main diseases associated with inadequate provision of safe water and sanitation, such as diarrhea, guinea worm, trachoma and schistosomiasis (UNDP, 2006). Diarrhea is one of the leading diseases that causes death and illness, killing 1.8 million people and causing approximately 4 billion cases of illness every year. Ninety percent of diarrheal deaths are children under the age of five, mostly in developing countries (UN-Water, 2009).

For every child that dies, countless others suffer from poor health and lost educational opportunities that lead to poverty in adulthood. Every episode of diarrhea reduces a child's calorie and nutrient uptake which sets back growth and development. UNDP estimates that parasitic infection retards the learning potential of more than 150 million children and water-related illness causes the loss of 443 million school days each year (UNDP, 2006).

Access to safe drinking water is one of the most important factors to break the cycle of disadvantage and poverty. Access to safe water improves health, increases a child's ability to go to school and allows adults to keep the strength they need to work. WHO estimates that 94% of diarrheal cases are preventable through modifications to the environment, including interventions to increase the availability of clean water and to improve sanitation and hygiene (Prüss-Üstün and Corvalan, 2006).

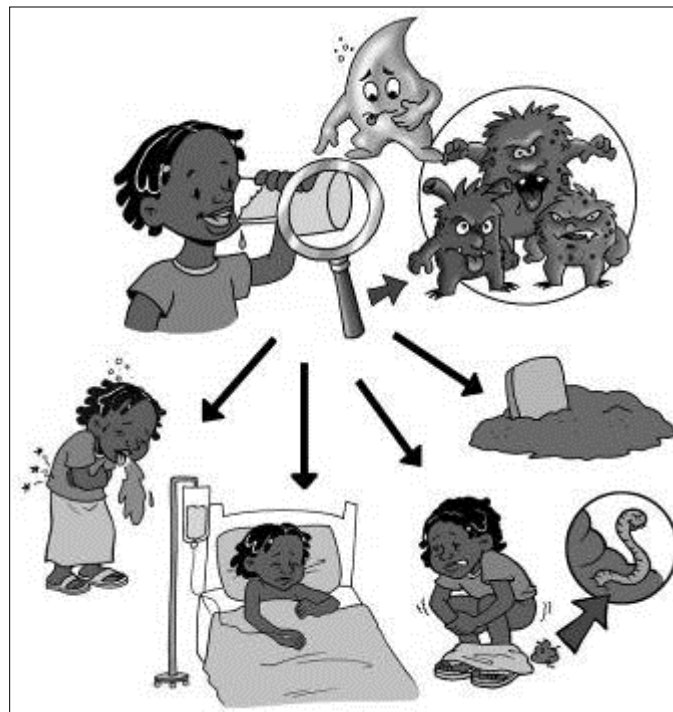

Contaminated water contains microbes that make us sick

Providing basic sanitation to the 2.6 billion people who currently lack access is an essential long-term goal that will yield great health and economic benefits. Basic sanitation is critical to improving public health because it keeps pathogens out of drinking water, food and the living environment, which in turn reduces the risk of disease transmission. Studies have shown that improved sanitation can reduce diarrheal incidence by a third. When combined with safe water and improved hygiene, a reduction of 60-70% in diarrheal incidence can occur (Esrey et al., 1991; Fewtrell et al., 2005).

The economic benefits of sanitation are also persuasive. Every US\$ 1 invested in improved sanitation sees an average of US\$ 9 return in value. Those benefits are experienced specifically by poor children and in the disadvantaged communities that need them most (WHO, 2008).

1.2 What is Sanitation?

Sanitation is a system of interventions used to reduce human exposure to disease by creating a clean living environment and instituting measures to break the cycle of disease. These interventions usually involve hygienically managing human and animal excreta, solid waste, and wastewater; controlling disease vectors; and providing washing facilities for personal and domestic hygiene. Environmental sanitation requires that both behaviours and facilities work together to form a hygienic environment. (EAWAG & WSSCC, 2000)

There are many simple, affordable sanitation technologies and practices that are appropriate for use in developing countries. This manual covers the following topics:

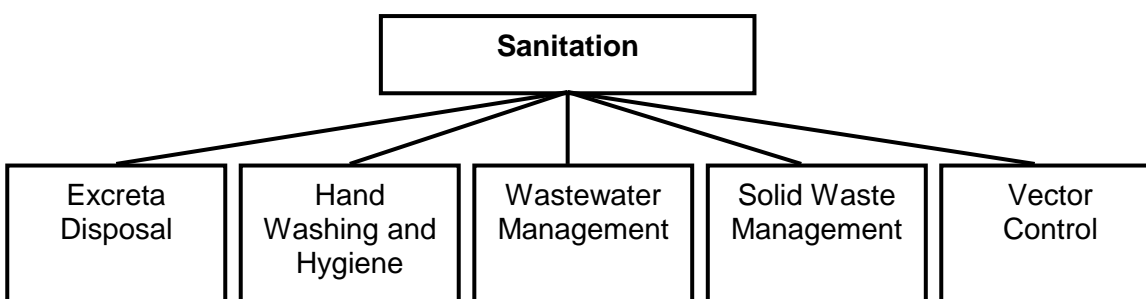

1.3 Contributing to the Millennium Development Goals

The Millennium Development Goal (MDG) Target 7c calls for a reduction by half the proportion of people without sustainable access to basic sanitation by 2015. The target is to reduce the percentage of people without sustainable access to basic sanitation to 23% by 2015 (WHO/UNICEF JMP, 2010). Progress towards meeting the target is tracked by the WHO/UNICEF Joint Monitoring Programme for Water Supply and Sanitation (JMP). In order to estimate access to basic sanitation, the JMP is required to use the MDG indicator of the proportion of a population using an improved sanitation facility, urban and rural.

Because definitions of improved sanitation facilities can vary widely within and among countries and regions, the JMP has defined a set of categories for “improved” and “unimproved” sanitation facilities.

An **improved sanitation facility** is defined as one that hygienically separates human excreta from human contact. Unimproved sanitation facilities are considered unsatisfactory because of their adverse effects on public health; however, existing facilities may be upgraded in various ways to prevent human contact with excreta.

What Are Improved Sanitation Facilities?

Improved Sanitation Facilities	Unimproved Sanitation Facilities
<ul style="list-style-type: none"> • Pit latrine with slab • Ventilated improved pit (VIP) latrine • Composting toilet • Flush or pour-flush discharging to: <ul style="list-style-type: none"> - pit latrine - septic tank - piped sewer system 	<ul style="list-style-type: none"> • Pit latrine without slab, or open pit • Bucket • Hanging latrine • Flush or pour-flush discharging to elsewhere • Shared facilities of any type • No facilities, bush or field

(WHO/UNICEF JMP, 2010)

Most of the 2.6 billion people who do not have access to improved sanitation facilities live in South Asia; however, there are also large numbers in East Asia and Sub-Saharan Africa.

2.6 billion people – 72% of whom live in Asia – do not use improved sanitation facilities

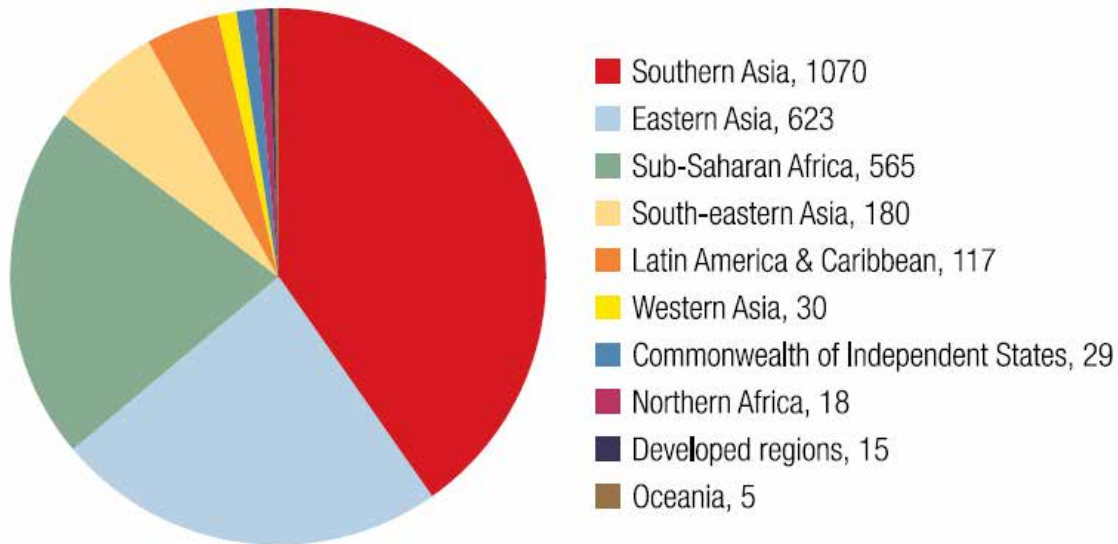

Figure – Regional distribution of the 2.6 billion people not using improved sanitation facilities in 2008, population (millions)

(WHO/UNICEF JMP, 2010)

As of 2008, the JMP reports that the proportion of the population using improved sanitation facilities is increasing in all developing regions. South Asia and Sub-Saharan Africa are the only regions where less than half the population use improved sanitation facilities. Open defecation is declining in all regions and has decreased worldwide from 25% in 1990 to 17% in 2008. Open defecation is still most widely practiced in South Asia and Sub-Saharan Africa at 44% and 27% of the population respectively. By contrast, open defecation is now practiced by only 4% of the population in North Africa and East Asia and 3% in West Asia (WHO/UNICEF JMP, 2010).



Figure – Worldwide use of improved sanitation facilities in 2008

(WHO/UNICEF JMP, 2010)

Significant disparities exist between rural and urban access to sanitation. Rural areas continue to see a lower percentage of the population using improved sanitation and a higher number of people without improved facilities. Of the approximately 1.3 billion people who gained access to improved sanitation during the period 1990-2008, 64% live in urban areas. However, urban areas, though better served than rural areas, are struggling to keep up with the growth of the urban population.

Even at the current rate of progress, the world will miss the MDG target by 13 percentage points. Unless huge efforts are made, the proportion of people without access to basic sanitation will not be halved by 2015. Even if the MDG target is met, there will still be 1.7 billion people without access to basic sanitation. If the trend remains as currently projected, an additional billion people who should have benefited from MDG progress will miss out, and by 2015 there will be 2.7 billion people without access to basic sanitation (WHO/UNICEF JMP, 2010).

Summary of Key Facts



- 2.6 billion people do not use improved sanitation
- Proportion of people using improved sanitation facilities is increasing in all developing regions
- Use of improved sanitation is higher in urban areas than in rural areas
- At the current rate of progress the world will miss the MDG target by 13 percent
- Major progress in the use of improved sanitation is undermined by population growth

(WHO/UNICEF, 2010)

1.4 Improving Sanitation

Defecation and sanitation practices are a result of many factors including:

- Tradition
- Habit
- Cultural norms
- Local norms
- Economics
- Knowledge

Traditional sanitation practices may no longer work due to population increase, lack of space and changing environmental conditions. The risk of disease transmission rises as the number of people defecating, living and working in the same area increases. People are often unaware that their defecation and hygiene practices are making them sick.

Achieving basic sanitation in a community relies on introducing new technology such as latrines and changing people's behaviour. It can be very difficult to get people to talk about their behaviour and it may take months or years to change habits that have been rooted in tradition or that have taboos and superstitious beliefs attached to them.

Consistent use, proper operation and maintenance and good hygiene practices are critical to achieving long lasting benefits from improved sanitation. Awareness and education within the community is essential to ensuring that sanitation improvements are accepted, adopted, correctly practiced and consistently used.

Components Required for Improving Sanitation

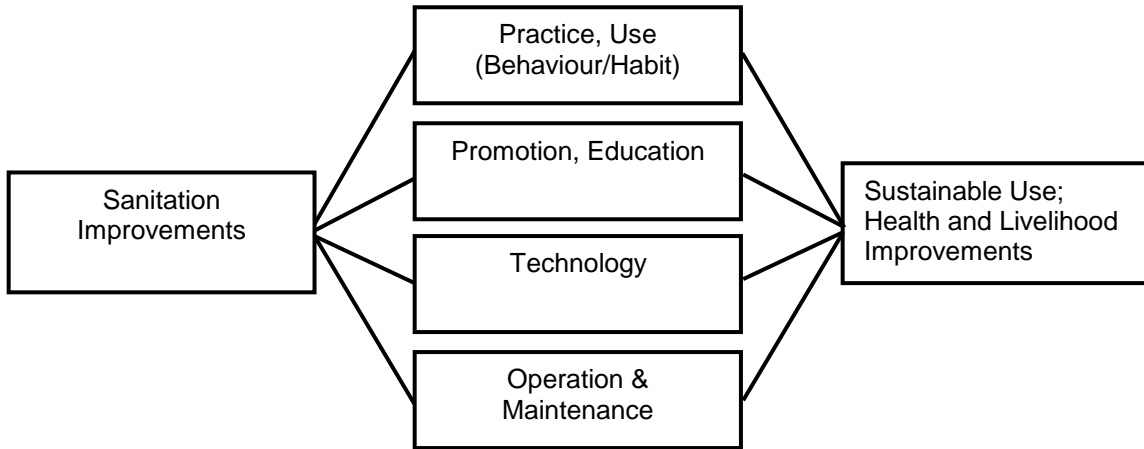

1.5 Health Impacts

The majority of the infectious diseases affecting the world's poor are linked to unsafe defecation practices, poor solid waste management and inadequate wastewater disposal. The pathogens from these wastes can spread across the ground's surface where they come into contact with people or food and eventually enter surface waters. They can also seep into the ground and contaminate ground water.

There are four different categories of pathogens that will be explained in the following sections: **bacteria, viruses, protozoa and helminths**. These pathogens can be transferred to humans in different ways. The following table explains the four ways pathogens are passed to a human and the diseases they can cause as well as how to prevent contact with them.

Water-Related Diseases

Type	How We Get Sick	Possible Diseases	How to Stop Getting Sick
Water-borne	Drinking water with pathogens	Diarrhea, cholera, typhoid, shigellosis, hepatitis A and E	Improve drinking water quality by removing or killing pathogens.
Water-washed	Pathogens touch the skin or eye	Trachoma, scabies	Provide enough water needed for basic hygiene. Improve basic hygiene practices.
Water-based	Pathogens go through the skin	Schistosomiasis, guinea worm	Do not bath or swim in water that is known to be contaminated. Improve water quality by removing or killing source of pathogens.
Water-insect vector	Pathogens are passed on by insects that breed or live in water, such as mosquitoes	Malaria, dengue, yellow fever, filariasis, river blindness, sleeping sickness	Prevent insects from breeding in water. Use pesticides to control insects. Prevent insects from biting by using bed nets and wearing long clothes.

1.5.1 Pathogenic Bacteria

Bacteria are very small single-celled organisms that are present everywhere and are the most common living things found in human and animal feces. Drinking water that contains feces is the main cause of water-related diseases.

Diarrhea is a major symptom of the most common water-related diseases caused by pathogenic bacteria. These diseases include *cholera*, *shigellosis* (also known as bacillary dysentery) and *typhoid*. About 1.5 million people die every year from diarrheal diseases (WHO/UNICEF, 2008).

Cholera is no longer an issue in countries that have basic water, hygiene and sanitation standards. However, it is still a problem where access to safe drinking water and adequate sanitation practices are limited. Almost every developing country in the world experiences cholera outbreaks or lives under the threat of a cholera epidemic (WHO, 2007).

Typhoid is also common in places that do not have safe drinking water and proper sanitation. Typhoid symptoms include diarrhea and fever. There are an estimated 17 million cases of typhoid worldwide resulting in 600,000 deaths (WHO, 2007).



1.5.2 Pathogenic Viruses

Viruses are the smallest of microorganisms. Viruses are unable to reproduce by themselves and must use another living thing to make more viruses. It is difficult and expensive to study viruses so we know less about them than other pathogens.

Some pathogenic viruses found in water can cause *hepatitis A* and *hepatitis E*. Hepatitis A affects the liver and is common throughout the developing world. It afflicts 1.5 million people every year (WHO, 2004).

There are other viruses that are passed on by certain types of mosquitoes. Mosquitoes spread viral diseases such as *Dengue Fever* (symptoms include fever, rash, joint pain), *West Nile Fever* (symptoms include fever, joint pain, inflammation in the brain), and *Japanese Encephalitis* (symptoms include fever, weakness, inflammation in the brain). Most of these diseases occur in tropical regions where the types of mosquitoes that transmit these diseases exist.

1.5.3 Pathogenic Protozoa

Protozoa are larger than bacteria and viruses. Some protozoa are parasites that need a living host to survive. They weaken the host by using up the host's food and energy, damaging its internal organs or causing immune reactions.

Amoeba, *cryptosporidium* and *giardia* are some of the pathogenic protozoa found in water that can cause diarrhea. They are found mainly in tropical countries. Amoebic dysentery is the most common illness and it affects around 500 million people each year.

Some protozoa like *cryptosporidium* are able to form cysts which allow them to stay alive without a living host and to survive in harsh environments. The protozoa cysts become active once the environmental conditions are optimal for their development.

Malaria is another protozoa that is passed on by mosquitoes. About 1.3 million people die each year of malaria, 90% of whom are children under the age of five. There are 396 million cases of malaria every year, most of them occurring in sub-Saharan Africa (WHO, 2004).

1.5.4 Pathogenic Helminths

Helminths are worms. Pathogenic helminths are generally passed through human and animal feces. Some spend part of their life in hosts that live in water before being passed on to people through the skin. For others, the infection route is by ingestion or by vectors such as mosquitoes. Many can live for several years in a human body. The WHO estimates that 133 million people suffer from worms and about 9,400 people die from them each year (WHO, 2000).

Common types of pathogenic helminths that cause illness in developing countries are *round worms*, *pin worms*, *hook worms* and *guinea worms*. *Schistosomiasis*, also known as bilharzia, is caused by the trematode flatworm. This disease affects about 200 million people worldwide and causes severe symptoms such as liver and spleen enlargement, fever, rash, abdominal pain and painful urination. *Schistosomiasis* is often associated with large water resource projects--such as the construction of dams and irrigation canals--which provide an ideal breeding ground for the worm.

Reflection – What health problems might be associated with inadequate sanitation in your community?

1.6 Non-Health Impacts

The benefits of improved sanitation extend beyond just better health. No one wants to live in dirty, smelly, unsanitary conditions. A sense of comfort, pride and well-being within the entire community can be created by making improvements to sanitation practices such as:

- Containing and properly disposing of excreta
- Improving wastewater drainage around the home
- Collecting and properly disposing of solid waste

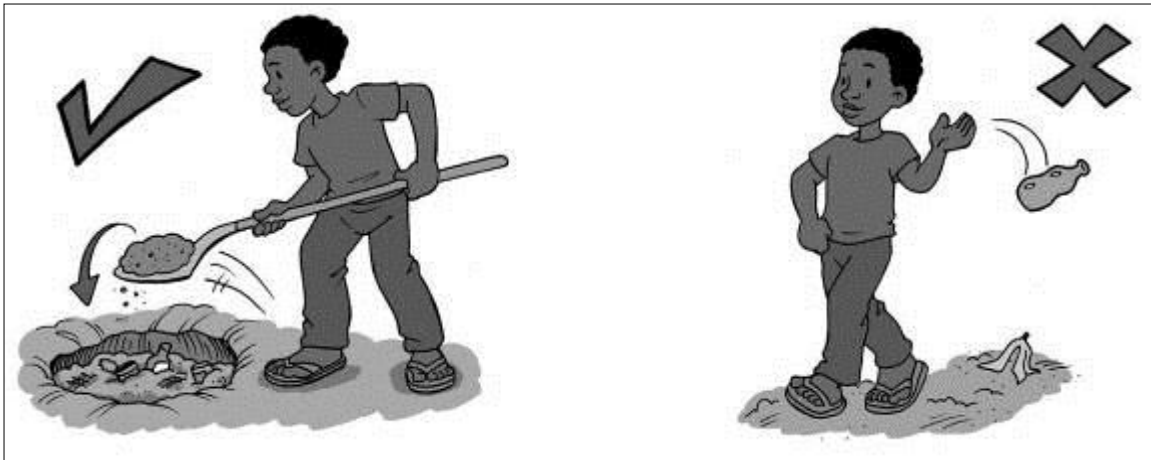

Surveys have shown that people perceive other important benefits from improved sanitation such as:

- Convenience
- Social status
- Modernization
- Privacy
- Security

Increased privacy and security can be a very important impact of improving sanitation facilities, especially for women and girls. Women and girls often wait until it is dark to defecate in areas where there are few or no sanitation facilities, and open defecation is the norm. This can put them at risk of being harassed, abused, or raped.

Also, this practice of delaying defecation and urination for many hours causes great discomfort and can result in physical harm. Women and girls may limit their food and fluid intake to lessen the discomfort and the need to defecate and urinate during the day. Women who have access to household or safe public latrines say that they have

increased dignity, privacy and comfort because they are able to use the facilities whenever they need to.

Why People Want Latrines

A survey of rural households in the Philippines found the following reasons for satisfaction with a new latrine, listed in order of importance:

1. Lack of flies
2. Cleaner surroundings
3. Privacy
4. Less embarrassment when friends visit
5. Reduced gastrointestinal disease

This survey result is not particular to the Philippines. In most parts of the world the top perceived benefits of improved sanitation include improved living conditions, convenience and dignity. There is less emphasis on improved health. The perceived benefits are good motivators when promoting improved sanitation.

(WHO, 1997)

Reflection – What other non-health issues are associated with poor sanitation practices in your community?

2 Promoting and Implementing Sanitation Projects

Changing sanitation habits can be a long-term and complex undertaking because it requires behaviour change and the introduction of new technologies. Organizations and governments have tried several methods and approaches to changing sanitation habits in many places throughout the world. These approaches promote sanitation and try to achieve long-lasting behaviour changes within the community. In general, the most successful approaches include:

- Community participation in decision making
- Motivation to change
- Appropriate technology selection

Before starting any new sanitation program, it is very important to understand the existing attitudes and beliefs connected to excreta and sanitation. Many sanitation improvement programs have not been successful even though they have offered appropriate technological solutions. This is probably due more to cultural unacceptability rather than a failure in technology or a lack of available options.

This section will discuss behaviour change and various methods that can be used to encourage it. It is important to remember that each community is different and so the approach must be tailored to what will motivate the community. The following methods will be discussed and can be combined to achieve the best outcome for a particular community.

- Awareness and education
- Health education and subsidized sanitation
- Incentive-based sanitation
- Integrated/holistic approaches
- PHAST
- Social marketing
- Community Led Total Sanitation
- Water and Sanitation Users Groups

2.1 Behaviour Change

Before going on to practical issues, it is important to understand the factors that influence behaviour. Human behaviour is the way people act, especially in relation to the situation they are in or the people they are with. Habits are ingrained and sustained behaviours—often developed in childhood—which are not easily lost.

The only way to change long held habits is to understand the factors that shape the behaviour and intentions of any individual. Once it is understood why people act the way they do, then the focus can move to what they need. Having their perspectives in mind will determine the kinds of promotion activities that will be best.

Model of Behaviour Change

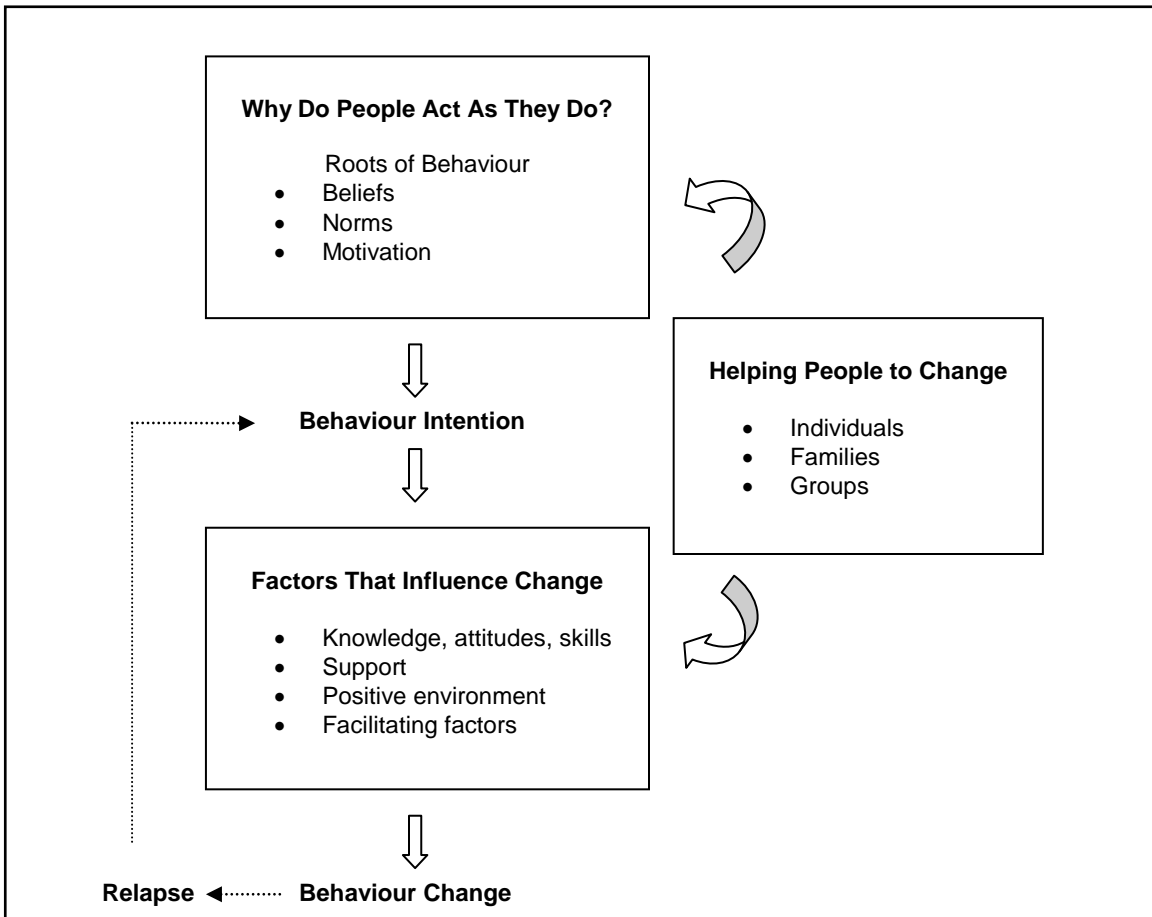

(Adapted from Network Learning, 2003)

2.1.1 Why Do People Act As They Do?

Beliefs

Each person has a set of beliefs that were learned in childhood. These include religious beliefs and beliefs about behaviour, but they cover almost every action and decision. Some beliefs lead to healthy behaviour. For example, many people believe that fruit is good for you—and it is—so they eat lots of fruit. Some beliefs may not lead to healthy behaviour. For example, some may think that at the end of a day of hard work, a plate full of rice is good food; it fills the stomach. In terms of meeting nutritional needs, it is indeed appropriate for people doing hard outside work. However, if you sit behind a desk all day, eating a bowl of rice for dinner may cause you to put on weight.

Norms

Norms are the normal ideas and behaviours in a society or community. When dealing with sanitation, a norm may be to anal cleanse with water while another may be to wipe with soft materials. In some communities it is to defecate in the river, in others it is to use a latrine.

Motivation

If people are motivated to do or have something, they are likely to take action to accomplish it. If they are not motivated they will not take this action. For example, earning a good salary and having chances for advancement will motivate workers to do their work properly. If they are not paid and recognized for their efforts, they will probably put less effort into their work. In school, students who get compliments for doing their best will be motivated to work even harder. For parents, knowing that keeping sanitary conditions in the home will mean their children will be sick less often which will motivate them to build a latrine, keep their home clean and promote household hand washing.

Self Reflection - Chose an activity that you do regularly, something you would consider a habit. Some examples include how you exercise, how you greet someone, or how you eat a meal. Think about WHY you act the way you do. What are the beliefs, norms and motivations behind your behaviour?

Beliefs:

Norms:

Motivations:

2.1.2 Factors That Influence People to Change

Thinking about behaviour change in the form of a continuum—as shown in the following illustration Understanding Resistance to Change—is very helpful. Sanitation programs will be trying to reach a community of individuals who are all at different stages of beliefs, norms and motivation. Successfully influencing people's behaviour depends on understanding how their existing beliefs, norms and motivations affect where they are on the continuum.

While habitual behaviours are often learned at an early age, there are opportunities for change, especially at life-changing events. Key events for women are the birth of a baby and moving to a husband's home after marriage and learning the habits of the new household.

The Resistance to Change Continuum illustrates the stages that a person may go through while adopting a change in behaviour.

SARAR Resistance to Change Continuum

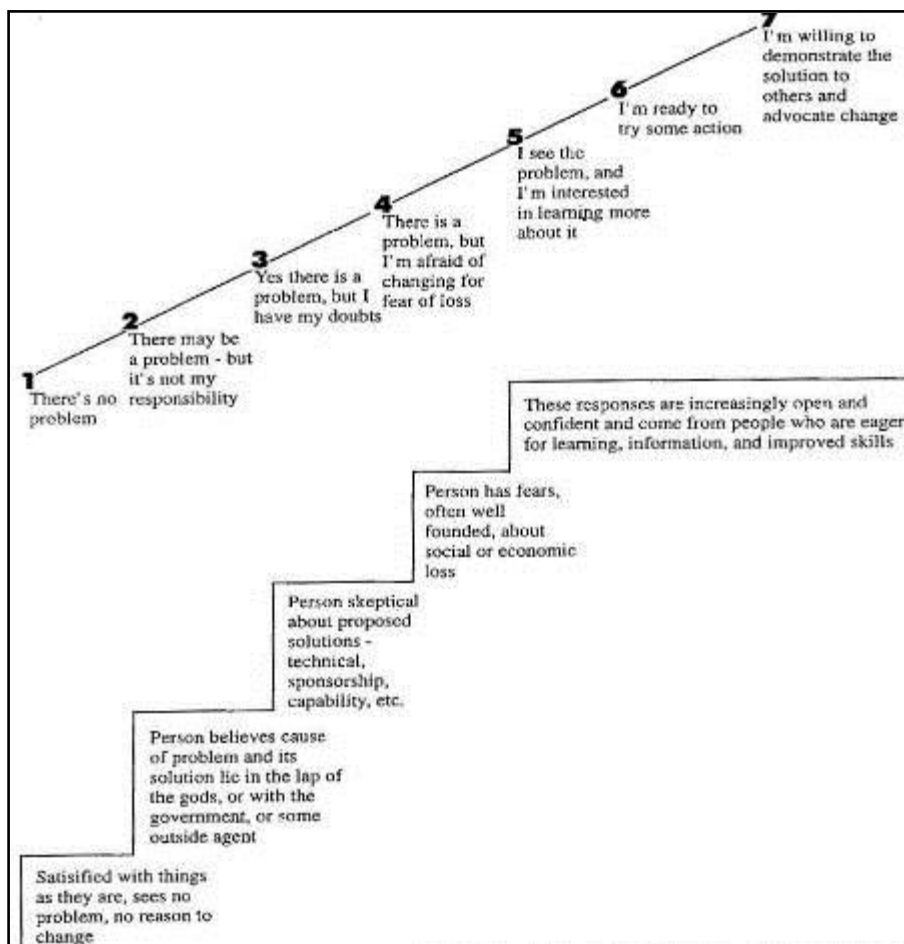

(UNICEF, 1997)

Knowledge, Attitude and Skills

When faced with people who need to adopt a healthier behaviour, ask yourself the following questions:

- What do these people need in order to change their behaviour?
- Do they need more knowledge about the subject or do they need to adopt a different attitude?
- What skills do they need?
- Where do they need assistance?
- Will this behaviour require more time or money?

Activity – What is Needed to Change?

Read silently or have a group member read out the following story:

A woman, who lives in a poor neighbourhood, has told you that she is tired of her family being sick with diarrhea. She believes that it is because of the drinking water she fetches from the local pond, but is unsure why. Her mother has told her it is because the water has been poisoned by an evil spirit. There is no other water supply available within walking distance of her community so she does not know what else to do. You have observed that the family's latrine is in poor condition and they lack water for basic hygiene, such as washing hands. Both she and her husband work hard all day to support their four children.

Identify the information you should give her to make it possible for her family to be healthier.

Knowledge:

Attitude:

Skills:

Support

Proper support from family, friends, community health promoters and peers can influence the motivation of people and help them to change behaviour. Some people can only be convinced to change their behaviour when someone they know well and trust tells them that it would be beneficial to make the change.

Positive Environment

Behaviour change does not happen until people experience the benefits that result from the change. A negative experience early on with the new behaviour or technology can hurt a person's desire to change. You need to make sure that a person's first experience is positive.

Experiences with a technology at a neighbour's or relative's home, a school, institution or workplace can also leave a strong positive or negative impression. Latrines constructed at community facilities such as schools and health clinics can be used as demonstrations to gain interest. However, these facilities must be well maintained and kept extremely clean. Past experiences with poorly maintained, smelly and dirty toilets may make people not want one near their home. Demonstration latrines that show the different stages of construction can also be useful to show the simplicity of design and construction. These can also be used to encourage discussion which leads to action.

As well, hearing positive stories about benefits that other people have experienced can act as a catalyst for someone to change their own behaviour. It is easier to convince people if they are told stories of benefits already achieved elsewhere. An example is, "More children are attending school now that latrines have been installed in the village" or, "There are fewer flies in the village since people started using latrines and disposing of their garbage properly."

Facilitating Factors

These go beyond the individual's own physical environment and affect everyone in the community. They include policy and laws that support healthy behaviour. For example, a community could choose to charge fines for defecating in public.

2.1.3 Helping People to Change

Community Health Promoters can help people as individuals, as members of families or as part of a group. In some cases, it is possible to help people on an individual basis only; in other cases it may be more useful and even necessary to help through the family or group, or to use all three levels at the same time.

We need to understand that the adoption of a new behaviour or technology in a community does not happen all at once. Instead, adoption starts with a few people and gradually spreads to the rest of the community over time.

The next graph shows how different types of people will adopt a new behaviour or technology earlier or later than others.

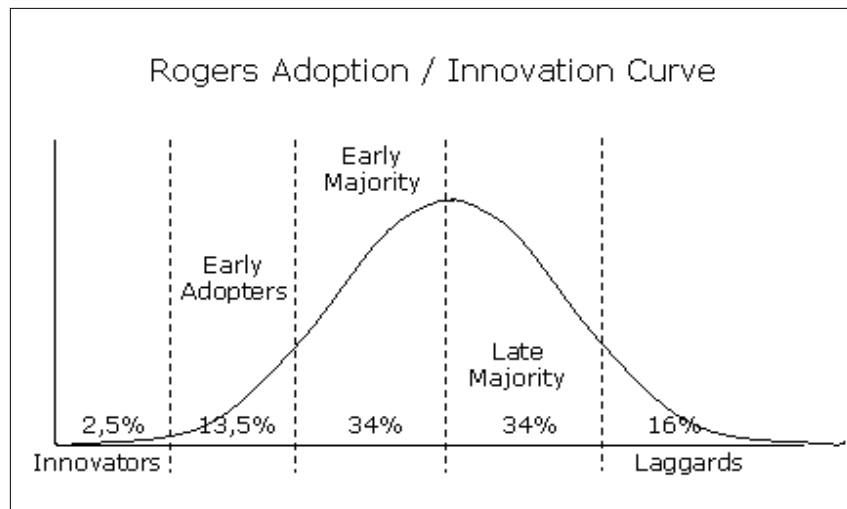

Source Unknown

The innovators and early adopters are open to new ideas and ready to take action. The early majority tend to be careful but more accepting of change than the average person. The late majority are skeptics who will adopt a new idea after the majority are already using it. The laggards are traditional people who are satisfied with things as they are and see no reason to change. They tend to be critical towards new ideas and will only adopt a new behaviour or technology if it has become mainstream or even tradition (Rogers, 1995).

Category	Values	Communication behaviour
Innovators	<ul style="list-style-type: none"> Obsessed with new ideas Risk taker Not constrained by the community 	<ul style="list-style-type: none"> Actively seeks new information through various channels
Early adopters	<ul style="list-style-type: none"> Open to new values Favourable to change High aspirations for advancement in the community 	<ul style="list-style-type: none"> Informal influence over the behaviour of others Active contact with those who positively influence decisions
Early majority	<ul style="list-style-type: none"> Deliberate in their actions 	<ul style="list-style-type: none"> Frequent interaction with local community
Late majority	<ul style="list-style-type: none"> Skeptical to new ideas Cautious Unwilling to take risks 	<ul style="list-style-type: none"> Passively receive information from local community
Laggards	<ul style="list-style-type: none"> Resists change Traditional, conservative Suspicious of innovations 	<ul style="list-style-type: none"> Somewhat isolated from the local community

(Adapted from Rogers, 1995)

A time will come in the process when enough people in a community have adopted the new behaviour or technology that the rate of adoption becomes self-sustaining. This is called the “critical mass” or “tipping point.” When this happens, the social pressure is great enough to encourage the late majority and laggards to change. They feel that they have no choice but to adopt the behaviour or technology or else they will be excluded from the community.

The “tipping point” can be used as an advantage when trying to encourage positive behaviour change in a community. A good strategy is to initially identify and help the innovators and early adopters. Providing incentives for early adoption can help create the momentum in the community needed to reach the tipping point. After these people have adopted the behaviour or technology, you can then change your focus to helping the late adopters and laggards.

Behaviour can also change gradually over the course of a few generations. Children tend to be early adopters because they learn new information and develop new expectations that they bring back to their family. Teaching and practicing good sanitation and hygiene in school and doing home visits with students can be effective ways to create awareness, increase household knowledge through the children and achieve change.

2.2 Choosing a Promotion Method

A project should start with a stakeholder analysis to understand the needs and preferences of the community and the current demand for sanitation. The community may not want a sanitation project because they do not realize the benefits of better sanitation or there are other priorities for projects such as drinking water. If there is no demand, you may have to create it and this can be a part of your plan. Your stakeholder analysis will help define appropriate methods and ensure local issues are addressed.

An important consideration is the starting point of the community, i.e. what the current practices are. Attitudes to sanitation are different around the world and can even vary from community to community. In some communities, open defecation is unacceptable and every household has a latrine which is consistently used. In other communities there is no tradition of latrine ownership and it is normal for people to defecate in the open. Taking these two scenarios as an example, the promotion approach would be different for the community that is introducing improved sanitation for the first time (starting from open defecation with no latrine use)



than it would be for the community that is upgrading existing sanitation technology and practices. Introducing latrines and stopping open defecation may require more of a shift in thinking and practice than simply encouraging people to upgrade. It seems logical that encouraging a series of small improvements would be the best approach. However, depending on circumstances it may be more appropriate to encourage large improvements to ensure that they are actually seen and identified as worthy of the time and effort invested. Having a clear vision of the current and desired behaviours and technologies is very helpful when choosing and combining effective promotion methods.

2.3 Promotion Methods

2.3.1 Awareness and Education

There are currently many sanitation improvement projects operating around the world. However, these projects are often not successful in their efforts to change behaviour over the long term.

Why do they not succeed? The emphasis is often placed on technology rather than on teaching people how to use and incorporate the technology into their lives. Public awareness and education are usually afterthoughts. By the time their importance is recognized, the project money has already been spent. Also, many projects use ineffective communication methods that don't reach the right people.

People need to be **aware** that they get sick from unsafe drinking water before **knowledge** about water, hygiene and sanitation can be introduced. Having knowledge then motivates people to take **action** and to change their behaviour.

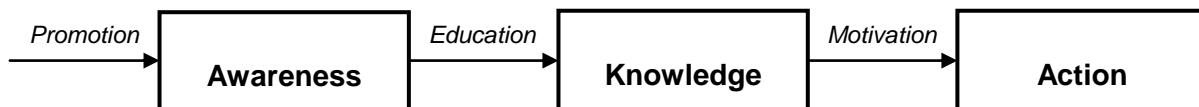

Two ways that can help move knowledge to action are 1) tying knowledge to people's morals and 2) turning the student into a teacher as quickly as possible (Kool, 2010).

Promotion and education are more than just a single event or activity in the community; they are on-going and long-term processes. While it is important to promote health benefits, projects must also address other benefits and concerns that come along with improved sanitation. It is important to consider the need for on-going support to households after the project has officially ended. Who will help a household if they have a problem or question? How will promotion and education continue once the project is finished?

There are different community members who can help contribute to awareness and education during and after a project. Some of them are listed below:

- **Community health promoters** - Individuals selected from the local community to receive training on safe drinking water, health and sanitation. They can be volunteers or paid positions.

- **Local health staff** - Existing local health workers who receive training on safe drinking water, health and sanitation. These workers can be volunteers, government staff or contract workers paid by the project for their activities.
- **Local entrepreneurs** - Local entrepreneurs have a vested interest in promoting sanitation since it leads to increased production and profits. Entrepreneurs generally focus on the particular technology that they are trying to sell and may not raise awareness about safe drinking water and health or provide education about other options.
- **Social marketing companies** - Commercial social marketing companies often act as part of a large program. Often social marketing focuses on a particular technology and may not raise awareness about safe drinking water and health or provide education about other options.
- **Government staff** - Local government staff is responsible for raising awareness of the importance of safe drinking water and health as part of a regional or national program. They could also be trained to teach people about sanitation options.

Below are two simple posters that can be used in communities to educate people about water, hygiene and sanitation.

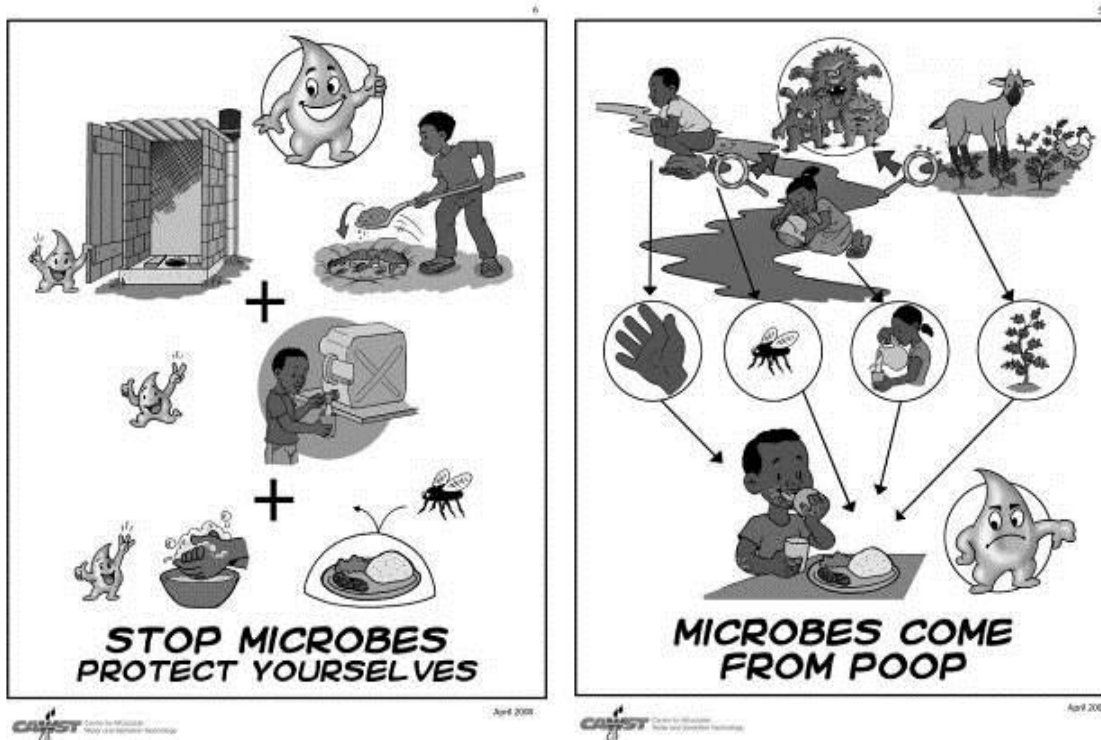

Educational posters for building awareness in communities about the ways we get sick from poor sanitation, and simple solutions.

Awareness and knowledge do not always lead to action. People may need help to become motivated and other promotion methods may need to be used alongside the awareness and education approach.

2.3.2 Health Education and Subsidies

A very common approach to promoting and implementing sanitation has been to provide health and hygiene education together with a subsidy for constructing a latrine. Often, the latrine slab is provided free of charge or at a reduced rate and the household is responsible for digging the pit and constructing the superstructure.

Explaining the health benefits, convincing people of the need for sanitation and then supporting them financially to construct a latrine sounds like a sensible and promising way to promote sanitation. However, this has had less success than would be expected. Improved health has proven to be a poor motivator for change. Also, subsidies are unsustainable and difficult to replicate at the level necessary to have a wide-scale impact. In other approaches, materials such as concrete, tin for a roof, or pipe are provided instead of money. However, people may never build a latrine because it is easy for them to accept the free materials and use them for something else instead.

The Subsidy Debate

Sanitation improvements can be relatively expensive, and this can be a huge barrier to building or upgrading a latrine. Often, money meant for sanitation is allocated to other priorities such as educating children. Combining subsidies, revolving funds and cost and component sharing opportunities with a range of latrine options can help to lessen the financial burden on households. It can also ensure that even the poorest members of a community are able to build latrines. However, as with all development initiatives, ensuring a sense of ownership is critical to the sustained use and maintenance of a technology. This can be enhanced by requiring the household to pay for the technology—or at least a portion of it—themselves.

Subsidies seem to be more controversial in sanitation than other programs. Some argue that if sufficient demand exists (or can be created) within a household to use a latrine (ensuring behaviour change) they will build one themselves without subsidy. Providing no subsidy is also argued to increase the sense of ownership of the latrine, contributing to a greater chance of sustained use and maintenance. The lifespan and sustainability of latrines built cheaply without any form of financial assistance is questionable. It remains unknown if households will rebuild a latrine when required in the future, especially if it must be moved or rebuilt every year. There is little information available to show if households do rebuild or upgrade latrines after formal sanitation programs have ended in the community.



2.3.3 Incentive Based Sanitation

Talking about excreta, defecation and urination can be difficult. These are often the subject of taboos and traditional beliefs, and many people are too embarrassed to discuss their personal habits. People are more willing to talk about water than excreta and this may partly explain why sanitation is often considered less important than water supply.

Some sanitation programs offer improved water supply as an incentive to encourage people to adopt better sanitation practices. A common arrangement is that all households or a certain percentage of the community must install latrines before constructing an improved water supply.

However, the latrines may not be used if people are building them without wanting to or without understanding why they should use them. People may view the time and effort they spent on constructing their latrine as a pointless yet necessary investment in order to get the water supply they want. It is possible that once the water supply is in place they may go back to open defecation and use the latrine as a storage shed.

Relying only on incentives may have limited impact on the sanitation situation within a community. Demand must first be created and programs must also be put in place to make sure that the latrines will be properly used and maintained over the long term.

2.3.4 Integrated / Holistic Approaches

Rather than viewing good sanitation as an end in itself, it can be seen as part of an integrated approach to improving many aspects of the health and livelihood of a community. For example, the concept of creating “model villages” often has a sanitation component. This is not a new approach but it has been refined over the years. An important aspect of this approach is community participation, which helps to identify the problems and issues faced by the community, priorities for addressing these problems and appropriate solutions. Obtaining funding for this kind of approach is often a challenge, as is committing to the time required to address several issues at once.

No issue stands alone. Each one depends on and relates to several other factors affecting people’s preferences, priorities and ability and willingness to act. Issues are linked to their causes, impacts and solutions. For example, maximum health impacts can be achieved when water, sanitation and hygiene issues are all addressed at the same time. Possible issues that could be addressed in an integrated approach are:

- Water supplies for domestic and agricultural uses
- Sanitation
- Hygiene
- Agriculture and food production
- Nutrition
- Health services
- Education and literacy for children and adults
- Transportation, access and roads
- Energy and communications
- Income generation and enterprise development

This approach takes a holistic and longer term view and may be highly effective and sustainable. To be successful, this approach requires substantial commitment and collaboration from all stakeholders involved: the community, donors, implementers and local and national institutions.

2.3.5 PHAST

PHAST stands for “Participatory Hygiene and Sanitation Transformation.” This approach is based on engaging the community to empower them to be involved in community planning. PHAST is a method that leads community members to collectively “work out what they want to do, how it should be implemented, how it should be paid for and how to make sure the community can sustain it in the future” (Wood et al., 1998). This method and the tools used aim to make the process of decision making fun while building self-esteem and a sense of responsibility for one’s decisions. Almost all the tools in this method only use pictures and no words in order to be inclusive to all members of the community, including those who cannot read. Below are PHAST’s seven steps to community planning for the prevention of diarrhoeal disease.

Seven steps to community planning for the prevention of diarrhoeal disease		
STEP	ACTIVITY	TOOL
1 Problem identification	<ol style="list-style-type: none"> 1. Community stories 2. Health problems in our community 	<ol style="list-style-type: none"> 1. Unserialized posters 2. Nurse Tanaka
2 Problem analysis	<ol style="list-style-type: none"> 1. Mapping water and sanitation in our community 2. Good and bad hygiene behaviours 3. Investigating community practices 4. How diseases spread 	<ol style="list-style-type: none"> 1. Community mapping 2. Three-pile sorting 3. Pocket chart 4. Transmission routes
3 Planning for solutions	<ol style="list-style-type: none"> 1. Blocking the spread of disease 2. Selecting the barriers 3. Tasks of men and women in the community 	<ol style="list-style-type: none"> 1. Blocking the routes 2. Barriers chart 3. Gender role analysis
4 Selecting options	<ol style="list-style-type: none"> 1. Choosing sanitation improvements 2. Choosing improved hygiene behaviours 3. Taking time for questions 	<ol style="list-style-type: none"> 1. Sanitation options 2. Three-pile sorting 3. Question box
5 Planning for new facilities and behaviour change	<ol style="list-style-type: none"> 1. Planning for change 2. Planning who does what 3. Identifying what might go wrong 	<ol style="list-style-type: none"> 1. Planning posters 2. Planning posters 3. Problem box
6 Planning for monitoring and evaluation	<ol style="list-style-type: none"> 1. Preparing to check our progress 	<ol style="list-style-type: none"> 1. Monitoring (checking) chart
7 Participatory evaluation	<ol style="list-style-type: none"> 1. Checking our progress 	<ol style="list-style-type: none"> 1. Various tool options

Source: (Wood et al., 1998)

An example of one of the tools is the sanitation ladder. This activity displays latrine options and improvements and can help communities decide what they would like. The sanitation ladder starts from open defecation and each step up has technological improvements up to improved latrines with vents, hand washing stations and permanent structures. It may seem logical that a series of small steps from one level to another would be the best approach to adopt. However, depending on circumstances it may be more appropriate to “leap” a number of steps to ensure that the improvement is actually seen as an improvement worthy of the time and effort invested in moving up the ladder.

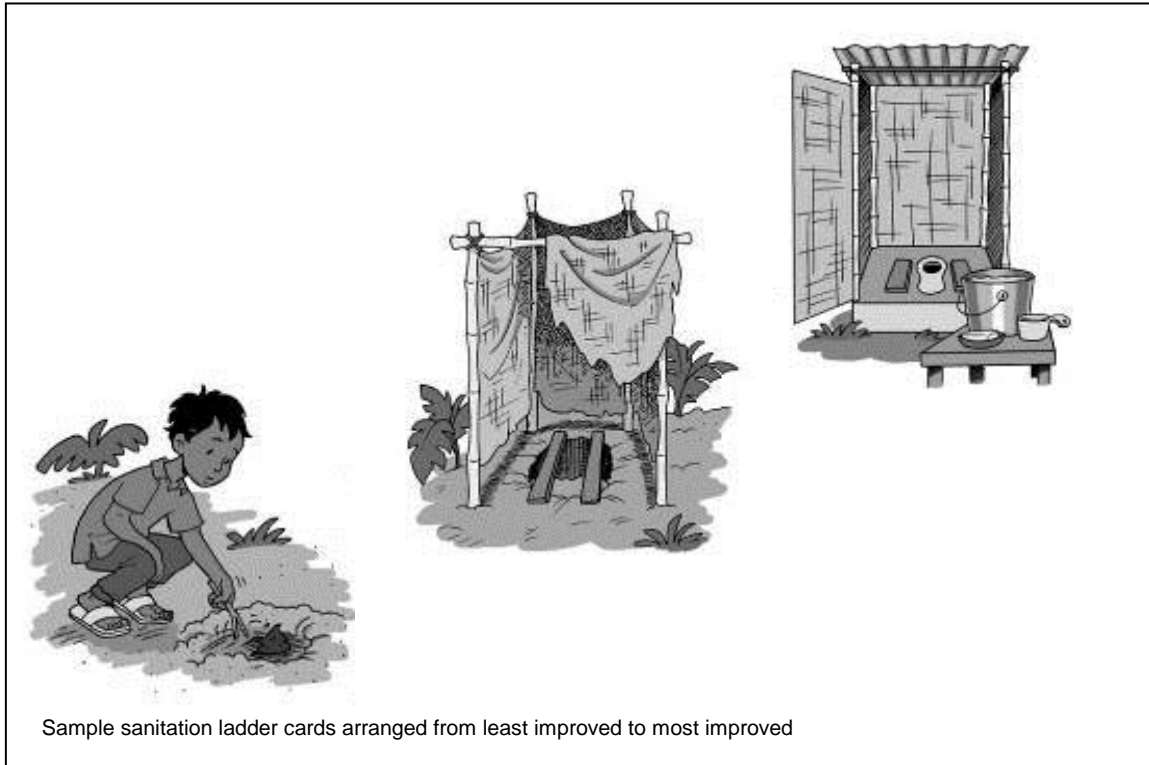

2.3.6 Social Marketing

Social marketing of sanitation is a relatively recent development. Social marketing uses commercial marketing tools to target different groups of people to promote habit change and health benefits. Social marketing often reduces the time necessary to change unhealthy habits. Tools include house-to-house education programs, community events such as theatre performances, and training school children to teach their parents to adopt these new habits. People may not readily accept any improvements in their sanitation and situation without targeted and culture-specific education and social marketing programs (Oldfield, 2007).

The concept of the “Four P’s” of conventional marketing—product, price, place and promotion—also apply in social marketing with some differences. As well, a fifth “P” is often added to social marketing: policy. Policy can serve to effectively enable good behaviour and discourage bad behaviour (Scott, 2005).

What is Different about Social Marketing?

Product: This may be a tangible item (condom, oral rehydration sachet, home toilet), a service (AIDS testing, pit emptying) or a practice (vaccinate children, wash hands with soap). Commercial marketers only want to sell the product; social marketers also want customers to use it correctly or behave differently.

Price: Commercial prices must cover all costs whereas social marketers might choose to subsidize certain items in order to reach the poor who may also have social and other “costs” to overcome.

Place: The product needs to be available to the target group and public channels such as government outreach workers or volunteers. Private shops and artisans can also bring the market close to customers.

Promotion: Creating demand for a totally new product or service is more challenging than the commercial practice of winning market share from competitors.

(Cairncross, 2004)

There are three key components to a social marketing campaign:

- **Target audience** – Who do you want to reach with your message?
- **Key message** – What are you trying to tell people?
- **Communication method** – How are you going to get your message out?

Identifying Your Target Audience

Your target audience may be women, mothers, school children, men, farmers—anyone you want to influence to change their behaviour. Primary target audiences are those who carry out poor water, hygiene and sanitation practices. Mothers and girls are often chosen as the primary target audience because they are usually the main caregivers for young children and are usually the most influential in a family setting.

While targeting mothers may be useful for initiating change at the household level, there is also a need to involve secondary target audiences who influence the target audience’s behaviour (e.g. fathers, children, mothers-in-law). There is also a third target audience which is very important: opinion leaders such as religious, political, traditional leaders and elders (UNICEF, 1999; WHO, 2002).



(UNICEF, 1999)

You should consider different activities that address all audiences. Individual practices affect the whole community. So if one sub-group changes their behaviour but another does not, the entire community cannot achieve the full health and environmental benefits of improved sanitation. Each segment of your audience can be addressed separately, so while you may arrange for house-to-house visits to reach mothers, street theatre may be more effective in reaching fathers and youths, and leaflets might be appropriate for local opinion leaders (UNICEF, 1999).

Designing Key Messages

Communication can be more effective if it focuses on benefits that are important to the target audience. Any promotion strategy needs to be based on an understanding of people's needs and local motivations. These could be as diverse as convenience, safety, privacy, health improvement or money saving. While good health may seem an obvious need from the public health point of view, it may not be the main concern of the local community. A targeted promotional strategy based on local motivating factors will be more successful than the standard public health based promotion (World Bank, 2002).

Focus on Local Needs and Motivations	Focus on Public Health
<ul style="list-style-type: none"> • Perceptions of community members. • Motivating factors are directly related to life in the community. <p>Example thoughts on hand washing:</p> <p><i>“If I wash my hands more often, it means that I have to carry more buckets of water from the well.”</i></p> <p><i>“Clean hands smell nice. I’m embarrassed if my hands smell after using the toilet.”</i></p>	<ul style="list-style-type: none"> • Perception of people outside the community, such as health staff. • Motivating factors are related to the prevention of disease. <p>Example thoughts on hand washing:</p> <p><i>“People will get sick more often if they don’t wash their hands.”</i></p> <p><i>“Hands are a link in the fecal-oral transmission route and the key to breaking that is by hand washing with soap.”</i></p>

(Adapted from Nam Saat Central, 2001)

It is also good to focus on positive and useful ideas about safe water and health (e.g. clarity, taste, good health, ease of use) rather than negative ones. It is not a good idea to create messages around the fear of disease and the death of children. Messages about diarrhea don’t always make sense to people and can disgust people because they are unattractive. The tone of the message should be upbeat and encouraging, especially if the ultimate goal of the behaviour change is a happy and healthy family.

**“I want to clean up stools and throw them in the latrine because...
...people can’t walk in them and my neighbours will respect me.”**

**“I want to wash my hands with soap after contact with stools because...
...it leaves my hands smelling nice and I feel good when I feel clean.”**



Positioning statement example (Credit: UNICEF, 1999)

Every society already has explanations and words to talk about disease, water, hygiene and sanitation, so messages should be based on existing practices and beliefs. Avoid contradicting traditional beliefs. Rather, integrate and include these beliefs into the messages. As well, try to use common words and situations that are familiar to everyone.

Too many messages at one time are confusing to people. The messages below are common in water, hygiene and sanitation education projects. Keeping it simple and focusing on two or three key messages is essential for good communication.

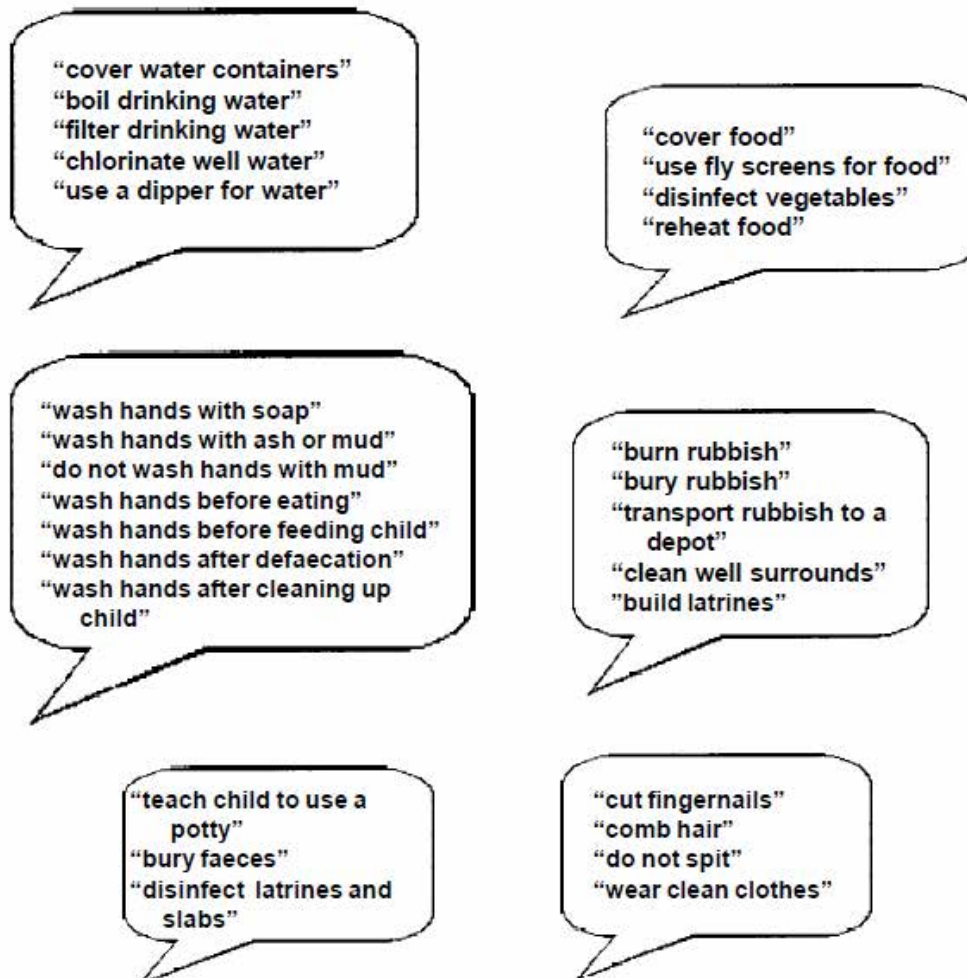

Too many messages (Credit: UNICEF, 1999)

Activity - Designing the Right Message

Between 1993 and 1996, research was conducted in Zou Department in the Republic of Benin, West Africa. The goal was to find out why some households had decided to change from open defecation and install a pit latrine at home, and why most others had not.

Interviews with many households identified that prestige and well-being were the main motivators for installing a latrine. Owning a home latrine allowed the owner and their family to:

- Display their connections with the urban world
- Show modern views, goals and new values gained outside the village
- Imitate some of the privilege, wealth and status of the Fon Royalty

People also wanted to protect their family's health and safety from dangers, accidents, snake bites and crimes associated with open defecation. There was also a desire for increased convenience, comfort and cleanliness associated with using a latrine. As well, people wanted to protect themselves from supernatural dangers associated with open defecation.

Preventing fecal-oral transmission of diseases (the classic health benefit used in most messages) was hardly mentioned. When infectious diseases were mentioned, they were traced to smelling or seeing human feces. Beliefs that the smell of feces made a person sick and weak, and that seeing it in the morning brought misfortune and bad luck, were widespread in the study area (World Bank, 2004).

Based on the information provided in the case study, design two or three key messages to encourage households to install a pit latrine. Try to focus on people's needs and local motivations. Remember to keep it simple and focus on the positive.

Message 1:

Message 2:

Message 3:

Selecting Communication Methods

There are many methods that have been used to engage and educate communities around the world. When selecting a communication method for a particular audience, the following questions should be considered:

- Who are the members of each target group?
- Where are they?
- How many of them are there?
- What languages do they speak?
- Who listens to the radio or watches television regularly?
- What proportion can read?
- Do they read newspapers?
- To which organizations and groups do they belong?
- Which methods of communication do they like and trust?



Communication through dance and drama
(Credit: Shaw, WEDC)

Finding out how many of the target audience reads papers, listens to the radio, belongs to social groups, etc. will help identify which methods are most suitable for each message. For example, using printed information in the form of pamphlets or posters is not appropriate if the majority of the community cannot read.

2.3.7 Community Led Total Sanitation

Community Led Total Sanitation (CLTS) is an approach that is mostly used in areas where open defecation is the norm. It is a mobilization approach to “ignite” the villagers to desire change. CLTS confronts a community about their dirty environment and provokes a decision by the community members to stop open defecation and build latrines. The approach focuses on the importance of social and cultural factors in promoting sanitation behaviour change instead of advocating purely economic or technological solutions. No subsidies are provided, but prizes or other incentives may be offered. Participation by all members of the community is achieved through various techniques including awareness raising, social pressure, embarrassment of those who do not change their behaviour and fines for non-participation.

CLTS is most suitable for situations where people practice open defecation and have no history or culture of using latrines. The initial aim is to completely stop open defecation in and around the community. The process can then build on this to eventually work on improving all aspects of sanitation in a community by tackling safe excreta disposal, wastewater and solid waste management and improved hygiene practices.

The definition of “Total Sanitation” can be quite broad and may include the following:

- No open defecation
- Wearing sandals while defecating
- Proper hand washing
- Good personal hygiene
- Good management of water points
- Safe Water
- Good wastewater management
- Good garbage management
- Clean domestic and community environment
- No spitting in public
- Covering food and water

This approach relies heavily on creating an initial sense of disgust and shame within the community. Facilitators point out and encourage discussions on the shortcomings of the sanitation conditions of the whole community and of individuals. One of the main messages that is emphasized is the fact that community members are “eating each other’s shit.” The core methods used in the CLTS program involve creating social pressure by shaming the residents for defecating in the open and for finding feces scattered in their villages. Other methods include calculating the potential amount of excreta found on the ground around their villages to shock community members and increase knowledge and awareness. One example of a knowledge and awareness tool is facilitating group discussions focused on disease and the cost of medications needed to treat excreta-transmitted diseases.

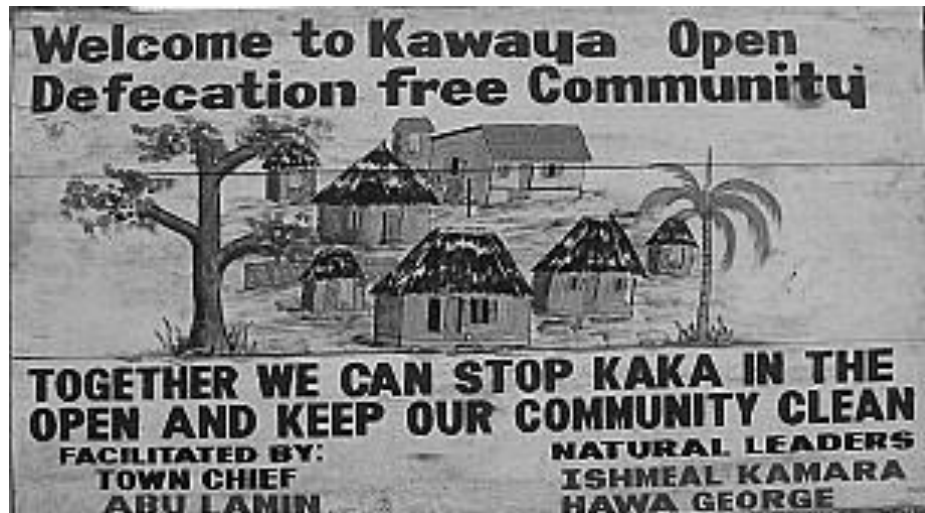

A sign outside an open defecation free community in Sierra Leone

Other tools used in CLTS include the following:

- **“Walk of Shame”** – One of the first activities carried out, facilitators lead community members to and around dirty areas of the village and insist on spending time and holding discussions in these places. Community members become ashamed that

visitors are exposed to the smell and the dirt, and this shame is then used to stimulate the community to take action.

- **Excreta calculation** – This process is used to illustrate the amount of excreta that is spread around the village each year. Where does it go? You eat it!
- **Defecation mapping** – Maps are made to show the places where people defecate in and around the village. Mapping illustrates that the village is surrounded by a sea of excrement.
- **Defecation flagging** – Flags are placed on excreta found in the open, ideally with the name of the person who defecated there on the flag. Commonly reported as being an activity for children.
- **Community statements/signs/notices** (e.g. “nobody defecates in the open in our village, and we will not allow anybody to do so”) – Signed statements require a commitment from all members of the community. Signs and notices are useful to warn visitors from other areas and to remind the residents of what is not acceptable.
- **Punishments and humiliations** – Community members who do not comply are subject to fines or other punishments. Humiliations would include the defecation flagging mentioned above, as well as singing songs, marking people’s doors, and ringing bells and blowing whistles when a person is caught defecating in the open.
- **Prizes and incentives** – Cash prizes or the installation of a water system or other facility can be offered to encourage villages to sign up. Prizes are sometimes offered for the first people to install latrines in a village.

The CLTS process must be carried out by a trained facilitator to avoid an initial hostile response and to guide the community to its own discovery of the issues and solutions.

Summary of Key CLTS Do’s and Don’ts

Do’s	Don’ts
✓ Facilitate	• Educate
✓ Let them realize for themselves	• Tell people what is good and bad
✓ Trigger local action	• Offer subsidy
✓ Let people innovate simple latrines	• Promote particular latrine designs
✓ Hand over to local leaders	• Be in charge
✓ Trigger self-mobilization through good facilitation	• Push for or demand action

(WaterAid Nepal, 2006)

Children and schools can play an effective role in stimulating behaviour change and are easily incorporated into the CLTS approach. They have much to contribute to the promotion of sanitation and to the creation of social pressure to stop open defecation. Children often get involved in flagging human excreta, marching and parading through

the community to promote sanitation, and being “on watch” for open defecators by blowing whistles and shaming those who defecate in the open surroundings.

The CLTS approach appears rather heavy handed and contrary to the traditional “softly-softly” development approach. However, it seems to be effective—once the process has begun, social pressure to improve sanitation becomes very high, and community members may have little or no choice but to comply or face social ridicule.

The CLTS approach commonly leaves selection and design of in the hands of the community. This allows each household to construct something they can afford. Some guidance on latrine design must be provided to try to reduce the risk of unsafe and unsanitary latrines. Generally, a range of latrine options is presented and households can choose one based on their preference and financial capability. They can get technical guidance from the implementing organization, community sanitation committee, local builders, sanitation entrepreneurs or other householders who have built latrines.

People who favour the CLTS approach are often against providing subsidies of any form; they maintain that if people are properly motivated to stop open defecation, then they will prioritize constructing whatever kind of latrine they can afford at the time without subsidy. Because people are initially highly motivated, they may build latrines out of whatever materials they can afford to buy, harvest or find locally. As a result, many temporary latrines are built, but they fill up and need to be moved, are destroyed during the next rainy season or become damaged by rot, insects or simply normal usage. It is unknown at this time whether people will typically rebuild or repair their latrines once the pressure and motivation of the CLTS project is no longer present. Ideally, people will realize the value of their latrine and will upgrade to more robust and comfortable models as they are able.

It typically takes up to 18 months or more to achieve total sanitation. Once the village is declared “open defecation free,” a certificate may be given along with a gift. In some cases, total sanitation cannot be achieved. The success of the approach depends on the attitude and motivation of the community. Occasionally, if the community is not ignited using the typical CLTS tools listed above, the implementer may have to walk away from the project or find new and innovative ways to address motivators and barriers to sanitation in the community.

This approach was first developed in Bangladesh in 1999 and has had some success in different parts of the world, notably Bangladesh, India, Nepal and Indonesia. The long-term sustainability of this approach still needs to be demonstrated (e.g. continued use of latrines, cleaning and maintenance, actions taken once latrines are full, upgrading latrines).

Walk of Shame Triggers Toilet Consciousness

Under the Total Sanitation Campaign (TSC), a comprehensive government program to improve sanitation in rural areas, the small village of Dabena in Bilaspur district, India, became the first recipient of ready-made toilets. Each of the 33 families of this village was provided with latrines that were constructed near their houses. But the majority of the people preferred the old and trusted ways of heading for the open fields to ease themselves.

Fed up with the stubborn refusal of villagers to use their private latrines, Sarpanch Dinesh Kaushik decided on drastic action. He issued an invitation to officials of the district Public Health Engineering Department (PHED), the nodal department implementing the TSC, to visit Dabena and directed the villagers to extend all hospitality to them.

What unfolded next is still remembered with horror by the inhabitants of Dabena. After the cursory greetings, the Sarpanch blandly suggested that the visitors might like to have a casual tour of the village. The excited villagers proudly displayed their tidy dwellings and the attached sparkling, but as yet unused, latrines for inspection. And then the Sarpanch edged the guests towards the open, lush green fields encompassing the village. As visitors and guests alike began the tough and unsavoury navigation around mounds of excreta and refuse scattered all around, the magnitude of the open toilet ground stood exposed. To drive the point home, the Sarpanch captured the dismayed and horrified expressions of the villagers on film which he screened for all after the infamous walk around the fields. It was dubbed the “Walk of Shame” and on the spot the villagers pledged to never again besmirch their green fields but to use their in-door toilets.

Within 20 days the entire village was declared a “Nirmal Gram” village, i.e., achieving total sanitation by virtue of using toilets, and the Sarpanch was given an award by district authorities.

Mr Kaushik then decided to bring about change in Bahtarai, where he also acted as Sarpanch. A resolution was passed that anyone found defecating in the open would be fined Rs 50 and those informing against the defaulters would get Rs 25. “The move was an effective deterrent and we collected Rs 750 in fines and awards,” claims Mr Mithulal Devangan, former Sarpanch.

(Bahuguna, nd)

2.3.8 Water and Sanitation Users Group

A Water and Sanitation Users Group (WSUG) acts as a liaison between the community and the implementing NGOs and government and acts on their behalf on water and sanitation issues.

In some communities a Water and Sanitation Users Group may already exist or can be formed at the beginning of a program. As an implementing NGO, it may be beneficial to work with the community to establish the WSUG, rules, operating guidelines and governance structure. The WSUG should select or elect members of the community and represent all stakeholders, including women and all socio-economic groups. Maintenance technicians and community health promoters should also be members of the group.

The WSUG will be an important point of contact for the residents of the community and the implementer and can perform the following functions:

1. Hold community meetings to discuss issues
2. Provide information about the community to implementers
3. Communicate information on water and sanitation options to the community
4. Communicate decisions regarding water and sanitation
5. Act as a contact point, a person the community can go to access information and ask questions

The WSUG may also collect and manage user fees, coordinate maintenance and ensure proper use. A committee can be formed regardless of the promotion approach used. It can be an important element in coordinating information, facilitating decision making and handling ongoing management of water and sanitation issues within the community.

2.3.9 Schools and Youth Clubs

Schools make for excellent places in which children can learn and practice good water, sanitation and hygiene behaviour. These topics are often included in the curriculum, but schools may lack the resources to provide adequate drinking water, sanitation and hand washing facilities. Teachers must be trained and committed to both teaching and modeling good practice by means of their own habits.

Clubs and youth groups can also provide effective settings in which to teach children and to promote good sanitation in the community. In one community in Nepal, the school teacher would take a class of students on visits to each of their homes. They would observe and discuss the sanitation and hygiene situation in each home, and find opportunities where the family could improve. In the same community, the student sanitation club would plant yellow flags on all the homes that did not have a latrine.

School Led Total Sanitation

School Led Total Sanitation (SLTS) places children at the centre of catalyzing total sanitation in schools, homes and the community. SLTS draws on success elements from a wide range of Community Approaches to Total Sanitation to create a complete package of sanitation and hygiene programming that begins at the school and extends through the community. Through participatory approaches, motivational tools, flexibility for innovation and building ownership at the local level, SLTS is accelerating latrine coverage across Nepal and creating a social movement for communities to become free of open defecation.

SLTS was developed in Nepal and has been being operated by UNICEF and the Government of Nepal since 2005. As of June 2009, SLTS had reached approximately 90,000 households and 500,000 people in 15 districts through 300 schools. Over 1,000 settlements in 10 districts have been declared ODF. Three districts are on their way to declaring district-wide total sanitation. Based on its success, SLTS has been incorporated into the Nepal Sanitation Master Plan—developed in 2009—and the Government of Nepal is replicating the SLTS program in all 75 districts. Additionally, other countries including Sierra Leone and Pakistan are adopting the SLTS approach.

For a practitioner's guide to SLTS see *Guidelines on School Led Total Sanitation* from the Nepal Steering Committee for National Sanitation Action, Department of Water Supply and Sewerage and UNICEF, Nepal.

(UNICEF, 2009)

3 Selection of Appropriate Sanitation Options

Many people simply want to be told which technology or solution is “best” or most effective. Unfortunately, because there are so many factors to consider, there is no easy formula that will answer this question. The “best” ought to be driven by a number of factors, including

- Socio-cultural acceptability
- Physical, environmental and technical acceptability
- Political and regulatory acceptability
- Stakeholder acceptability

Since sanitation is dependent on so many different factors in the household and community, there can be no standard solution.

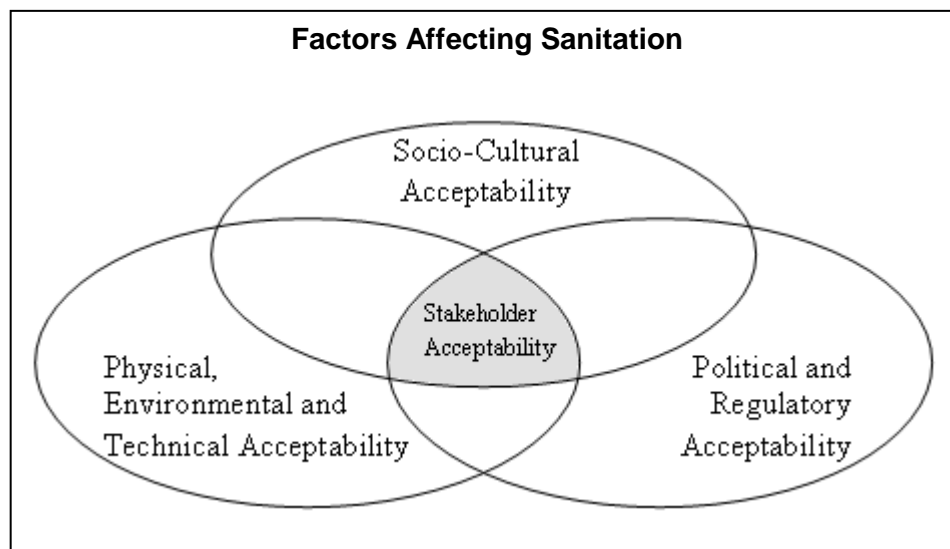

3.1 Social and Cultural Factors

In many societies and cultures, defecation, urination and excreta are surrounded by taboos, traditional and religious beliefs and what is considered polite and civilised.

Talking about defecation, feces, urine and sanitation can be difficult in many societies. This is shown by the many slang words and phrases that are used instead of speaking directly about these topics. When trying to begin a discussion it is important to remember that it may not be acceptable for women to talk about these subjects in front of men and vice versa.

Where people can defecate and who is permitted to use a latrine may depend on gender and age. Who may use a latrine may be influenced by superstition or by the practicalities of safety and privacy. Many influences may also determine practice, for example the method of anal cleansing may be determined by religion, local custom and/or simply the availability of cleansing materials.

Wide cultural variations and preferences exist in defecation practice.

Some people

- Defecate in the open
- Defecate in or near water
- Defecate in or near the house
- Defecate at sunrise and sunset
- Squat
- Use water for anal cleansing

But others

- Prefer a sheltered place
- Use a dry place
- Go far from the home
- Relieve themselves whenever the need arises
- Sit
- Use solid material for anal cleansing (e.g. paper, leaves, stones)

(Pickford, 1995)

Other social and cultural considerations include:

- Not being seen defecating or being seen going to defecate
- Not being seen entering or leaving a latrine
- The need to practice ritual bathing before and/or after defecation
- Not defecating near sacred places or other people's property
- Refusal to handle urine or feces
- Refusal to use human excreta or urine as fertilizer on crops
- Protecting or hiding feces to prevent their use in witchcraft
- Not mixing one's excreta with other people's
- Mother-in-law may not use same latrine as son-in-law
- Spirits reside in the ground, therefore digging a hole and defecating on them is unacceptable
- *Should not* defecate in "houses" (including latrine structures)

In some parts of Africa it is believed that if a woman uses a latrine she will only have female children. Since male children are commonly viewed as preferable to female, women may be put under great pressure to avoid using latrines.

The caste system that exists in parts of South Asia also determines which groups of people handle excreta and other waste. Most people have a natural dislike of excreta, however in some societies the handling of excreta is not viewed as particularly distasteful or difficult.

In Islamic cultures, latrines should be built perpendicular to the direction of Mecca to avoid issues with teachings that prohibit defecation or urination when facing or sitting/standing with one's back towards Mecca.

Whether toilets are designed for sitting or for squatting can be based on tradition, personal preference, physical capability or perceived modernity. Practicality also plays a role as it can be easier and less messy to wash while squatting than while sitting.

Cost also needs to be taken into consideration for each household. The cost of constructing a certain latrine may be affordable to one household but not to another within the same community. Households should be able to decide which latrine they are able and willing to build.



Activity – Social and Cultural Factors

Consider the following social and cultural factors and respond to the questions for your community.

- a. **Traditional practice** – How do people currently dispose of human excreta? Does it differ for men and women?

- b. **Anal cleansing** – What are acceptable and commonly used anal cleansing materials? Are people washers or wipers, or a combination of both? If people are wipers, what do they use to wipe? Do people dispose of anal cleansing material separately? Does it differ for men and women?

- c. **Latrine usage** – Do people squat or sit? Do the elderly, the sick and the young prefer to sit? Will people with disabilities use it? What is easiest for them? Does it differ for men and women?

Activity – Social and Cultural Factors Continued

- d. Attitudes to excreta – Do people handle and use human excreta as a fertilizer or for other purposes? Do people traditionally handle excreta when they empty latrine pits? If there is resistance, how strong is that resistance?

- e. Attitudes to defecation – Do people treat defecation as something very private? Do people defecate in the open? Does it differ for men and women?

- f. Gender – What are the different tasks and roles for men and women?

- g. Economics – How is wealth distributed within the community? What can different households afford? Is there a market for composted human excreta?

- h. Home ownership – Do people own or rent their homes? Would tenants improve sanitation in a rented house? Would the rent increase?

- i. Demand – Is there existing demand and motivation to improve the sanitation situation?

3.2 Physical, Environmental and Technical Factors

3.2.1 Space Availability

Improving sanitation in urban areas can be difficult; there may be legislative restrictions, space is often limited, dwellings are often rented, and land ownership can be uncertain especially in unplanned and informal settlements. This uncertainty can discourage people from investing time, money and effort into improving their sanitation.

Latrine emptying may be an option where there is enough space to build a latrine but not enough to build a new one when the pit is full. Latrines that are meant to be emptied must be built and lined so that the emptying can be done safely and without risk of the pit collapsing.

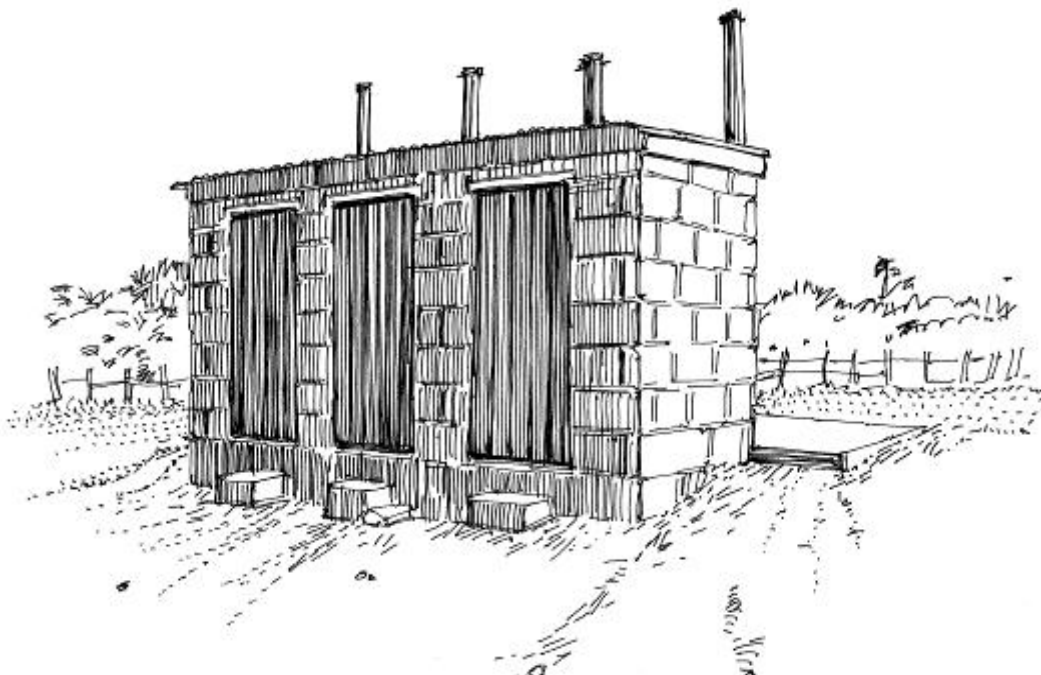

Public latrines with vent pipes (Credit: Shaw, 2005)

In very dense settlements there is often no space to build individual latrines. In these cases a communal system may be appropriate. The management and maintenance of public and communal latrines must be carefully planned with the users. The best approach to ensure that the latrines are cleaned and maintained properly may be to hire an attendant and caretaker whose wages are paid for out of fees collected from users. However, the fees must be structured so that all community members can use the facilities. It is important to avoid a situation where the very poor continue to practice open defecation because they cannot afford the latrine fees.

3.2.2 Soil and Groundwater Conditions

A goal of any chosen sanitation technology is to reduce the chance of excreta contaminating ground water, especially if groundwater is used as a source of drinking water, or is at risk of being washed out during a flood.

There is always a risk that pathogens and other contaminants from latrines will contaminate wells, boreholes and springs if they are installed too close to the latrine. When choosing where to construct a new latrine, it is important to first decide whether it matters that the latrine may contaminate the groundwater. If the local population does not use groundwater for drinking or other domestic purposes then from a health standpoint it isn't important that a latrine pollutes the ground water. However, if the population relies on groundwater for their drinking and domestic needs, then the potential for contamination of the groundwater must be carefully considered. In this case the water supply and latrines must be designed to minimize any cross contamination.



Raised latrine showing steps (Credit: Shaw, 2005)

The contamination of a ground water source by a nearby latrine is dependent on:

- The movement of pathogens and other contaminants through the soil
- The presence and flow of groundwater
- The time taken for pathogens to die off

Factors that influence pathogens' ability to survive and to travel through the ground are listed below. The best scenario is where all these factors combine to ensure that pathogens die off before they have the chance to contaminate any drinking water supply.

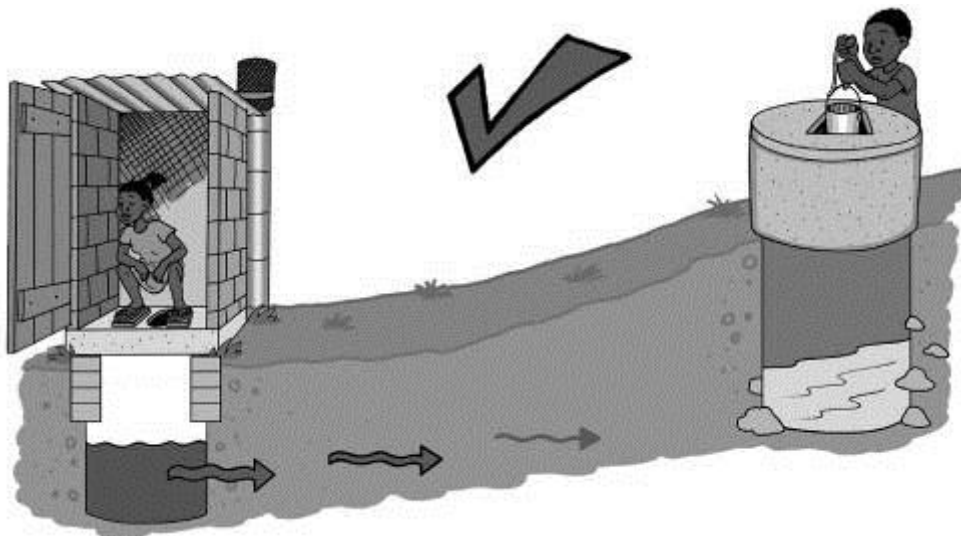

Site your latrine downhill and away from your water source

- **Size and lifespan of the pathogen and its ability to survive in hostile environments**
 - Larger pathogens are more likely to be trapped within the soil. For example, helminth eggs and protozoa are relatively large and are more easily trapped than viruses and bacteria which are much smaller and less likely to be filtered by the soil.
 - Some pathogens are able to survive in difficult environments. The lifespan of pathogens can be a few hours to several months. Most pathogens die off within about 25 days, however there are exceptions and survival times of some viruses are known to exceed 150 days. In the case of *E.coli*, its half-life (50% reduction in numbers) is estimated at 10-12 days with survival up to 32 days.
- **Type of latrine**
 - Wet latrines (e.g. pour flush latrines) contain large volumes of water that infiltrate into the ground and carry contaminants and pathogens quickly through the soil.
 - Dry latrines infiltrate smaller amounts of liquid into the ground, reducing the risk that contaminants will travel far from the pit.
- **Base of latrine below water table**
 - Pathogens are easily carried out of the latrine and through the ground by the water if the base of the pit is below the water table.
 - The base of the pit should be 1.5 metres above the highest water level so that almost no pathogens will reach the groundwater.
- **Coarse grained material and highly permeable soil conditions**
 - Highly permeable soils (soils that allow lots of liquid to pass through) allow pathogens to travel further and faster.
 - Highly permeable soils allow an easy and fast flow of groundwater.
 - Coarse grained soils have a higher permeability and lower ability to filter pathogens.
 - Some clay soils have the capacity to adsorb viruses (viruses accumulate on the surface).
- **Rapid flow of ground water**
 - Contaminants can be carried large distances in a short time if the flow of water through the ground is fast.

- **Direction and velocity of groundwater flow**

- Ground water usually flows downhill.
- The velocity of groundwater flow depends on the hydraulic gradient and the permeability of the soil.
- As a general rule, it is better to site latrines lower than drinking water supply points.

- **Distance between latrine and drinking water source/point**

- The greater the distance, the longer it will take for a pathogen to travel and it is more likely the pathogens will die or be trapped before reaching the drinking water collection point.

(Adapted from Harvey, 2007 and Sugden, 2006)

Minimum separation distances are often suggested as a general rule for siting sanitation facilities away from drinking water sources. These distances vary from 10 to 500 metres depending on the soil type and the organization or publication making the recommendation. The nature of the ground in a particular area is usually possible to determine, therefore a range of “safe distances” depending on soil type can be proposed. The table below gives minimum distances for different soil types.

Minimum Separation Distances for Latrines/Septic Tanks and Water Sources

Soil/Rock Type	Appropriate Minimum Distance (metres)
Silt	10*
Fine silty sand	15
Weathered basement rock (not fractured)	25
Medium sand	50
Gravel	500
Fractured rocks	Not feasible to use horizontal separation as protection

*10 metres is the minimum distance an infiltration system should be from a water source.

(Harvey, 2007)

A frequent recommendation is a 30 metre separation between a latrine and drinking water source; this distance is adequate in most circumstances. However, as with all general recommendations, there will be times when this rule will not work. There may be occasions when a shorter distance will be acceptable and other circumstances where contamination will still occur despite the 30 metre separation. An assessment of the soil and ground water conditions should be done if possible. The

results could allow a shorter safe separation distance or require a larger separation distance. Alternative options for both the water supply and sanitation should be considered if it is found that the separation distance must be larger than space permits.

3.2.3 Water Availability

Availability of adequate quantities of water all year round is important in determining whether pour flush or other water seal latrines are practical. (See section 5 for latrine types).

3.2.4 Local Availability of Materials

Using local materials to construct sanitation facilities has many advantages:

- Lower purchase and construction costs and money is spent in the local community.
- People are familiar with the materials, techniques and technology.
- Local replication of the technology is easier.
- Repair and maintenance is usually easier and can often be done by the householder.

Poor quality and limited availability of materials can limit the choice of latrine options.

3.2.5 Structure Design

It is usually recommended to make latrines in a style or design that “fits in” with traditional building designs. However, if latrines are being marketed as “modern and new” it may be better to build them so that they are different and stand out.



VIP latrine- thatched (Credit: Shaw, 2005)

Activity – Physical, Environmental and Technical Factors

Consider your community. Now respond to the questions about the following physical, environmental and technical factors that may affect how and where you construct sanitation projects.

- a. **Space availability** – Do families live in single-family or multi-family compounds, single-storey or multi-storey buildings? What is the typical size of a plot or family compound? Is there sufficient space for every household to build a latrine? Is there sufficient space to build a second latrine when the first one is full? Is there public space that could be used? Are potential latrine sites accessible by vehicle (e.g. truck, cart) to be emptied?

- b. **Soil conditions** – What is the local soil type? Is it physically possible to dig a pit? Is the ground self-supporting?

- c. **Groundwater conditions** – What is the depth to the groundwater table? How much do groundwater levels fluctuate in each season? Is the area prone to flooding? If so, how often and how severe? Is groundwater used for drinking? What other water sources are used by the community?

- d. **Water availability** – What water sources are used by the community? How is water transported to people's homes? Is there sufficient, easily accessible water available for flushing?

- e. **Local availability of materials** – Are cement, sand, gravel, pipe, septic tanks and superstructure construction materials (e.g. wood, bamboo, thatch, metal) readily available in the area?

3.3 Stakeholders

You must also consider all **stakeholders** who have anything to do with sanitation in a household or community before starting a project. This includes anyone who uses facilities, who is impacted by the sanitation condition, who helps to maintain the current situation or who can provide motivation to improve it. Individuals and households are the most important stakeholders in improving sanitation. However, there are many other stakeholders that influence the sanitation practice and situation in a community, including:

- Local leaders (e.g. political, social, or religious)
- Community health promoters
- Community based organizations, including women's and farmers' groups
- School teachers and principals
- Entrepreneurs and small business people
- Local, national and international NGOs who operate water, sanitation or health programs
- Local, district and national government bodies who make laws relating to water and sanitation and who may operate programs or provide subsidies
- Potential or existing donors

The perspectives, needs, opportunities, motivators and barriers for all stakeholders must be explored before launching a sanitation project. This can be done by conducting a stakeholder analysis as one of the first steps in planning a sanitation project. A stakeholder analysis also helps to identify what each group can contribute and how each contribution can be used throughout the project. A plan can be created once all the stakeholders' needs and contributions are understood. This plan will include how to approach and address the identified needs, how to market sanitation and how to make the largest impact in the community.

The stakeholder analysis should also consider the needs of particular users, including:

- **Elderly and disabled** – Design must make sure that access to and into the latrine is easy and that there are grab rails to help the user move and keep stable. They may be physically incapable of building their own latrine.
- **Children** – Many children are frightened of using latrines because they are scared of the dark and fear falling through the squat hole. Child-friendly latrines should be light and open, they should have a small hole and there should be space for another person to enter and assist the child.
- **Single parents, child-headed households and the ultrapoor** – These members of the community may not have the opportunity, the energy or the time to address their sanitation needs.

4 Latrine Design, Construction and Maintenance Guidelines

The following section describes general design, construction and maintenance guidelines that apply to most latrine types. Specific latrine types are discussed in Section 5.

4.1 Common Elements

4.1.1 Pits

- Circular pits are stronger and more stable than rectangular pits.
- Pit digging is normally done manually using hand tools.
 - When digging a pit, one person can dig approximately 1m³ per day in normal soils. In light sandy soils, this value can be 2-3m³ per day, in very hard stony ground this will be less than 1m³.
 - The minimum pit diameter to allow a person to work comfortably and efficiently is 0.9 metres. Two people require a minimum diameter of 1.2 metres.
- **The top 0.5 metres of all pits should be lined with impermeable material.** This gives a stable support footing for the slab and prevents potential erosion and undercutting of the slab during rainfall. This can be done with different materials, such as mortared brick, concrete blocks or a concrete ring
- Pit walls must be lined throughout the full depth of the pit if the ground is unstable and is at any risk of collapsing.
 - It may not be possible to determine the stability of the soil or to predict how it will react over time. It is useful to examine other pits in the area; if they are old, unlined and still stable then a lining is probably not required.
 - The pit lining must allow liquids to get through the walls of the pit into the soil, for example if bricks and blocks are used they should be built in a “honeycomb” arrangement.
 - Pit lining material must be strong and durable. Common materials include bricks and concrete blocks, wooden staves, steel sheets (often recycled) and bamboo.
- **A pit must always be lined, no matter the soil type, if it is designed to be emptied either by hand or machine.** This is to stop the pit from collapsing when the contents are removed.



Lining a latrine pit (Credit: Shaw, 2005)

4.1.2 Slabs

- Slabs provide a solid base that covers the pit. They incorporate a drop hole or pour-flush pan and footrests.
- Slabs can be made of wooden poles, concrete or reinforced concrete.
- Slabs can be surface finished with a mixture of cement to make them smooth and easier to clean.
- Pour-flush pans must be sealed to the slab to create a water seal that prevents smells rising up from the pit.
- Raise the slab above ground level to avoid flooding and erosion of the pit

Design and construction of slabs is discussed further in Appendix 4.

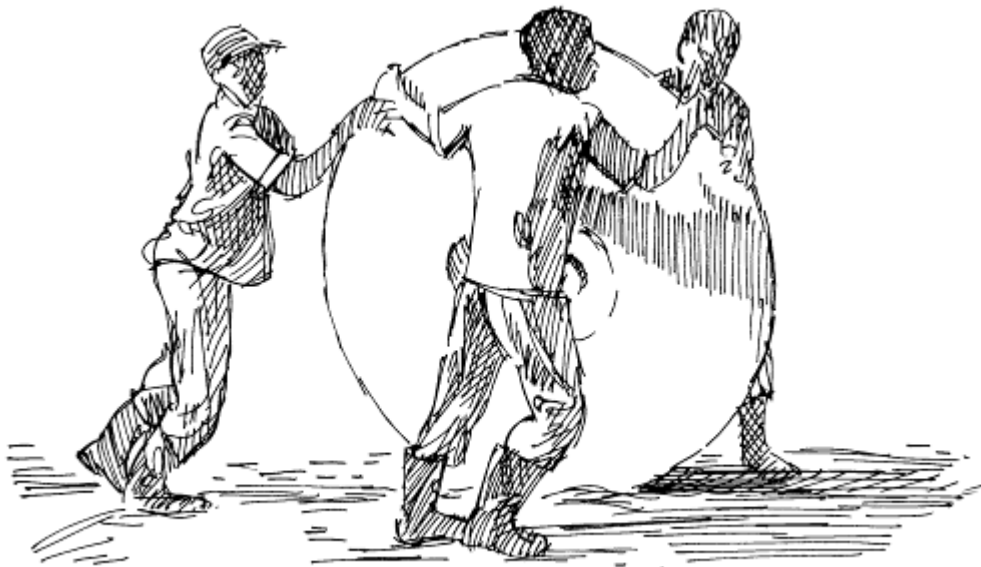

Three men rolling a latrine slab (Credit: Shaw, 2005)

4.1.3 Hole Covers

- A hole cover should be used with basic pit latrines to prevent flies and reduce smells.
- Try to make the covers so that they can be opened and closed with the foot (e.g. attaching a loop large enough for a foot to allow a person to move the cover off and back over the hole without touching it with their hands). Handles of covers can quickly become dirty or appear dirty, and users will not want to touch them.
- Covers should not be used on ventilated improved pit (VIP) latrines (see Section 5).

4.1.4 Superstructure

- Latrines are usually built with a screen or structure to provide privacy. These structures can be made of plastic, woven reeds, bamboo, wood planks, mud, concrete, brick, stone, etc. – local materials.
- Superstructures can have a door or a “labyrinth” entrance to hide the user from view.
- Superstructures for latrines may include windows or holes for light and ventilation (not including VIP latrine).

4.2 Maintenance

- Keep the door closed.
- Clean the floor daily using water and soap or ashes.
- During an epidemic, the floor should be cleaned daily with a disinfectant solution such as bleach.
- Do not put plastic, metal or glass down the latrine.
- To prevent mosquitoes and flies from breeding, the hole should be kept covered (excluding VIP latrine) and the pit contents kept as dry as possible.
- Ashes, soil or dry manure can be added to the pit to soak up moisture and possibly help reduce smells.
- Once pit contents reach within 0.5 metres of the floor, they should be covered over and a new pit should be built.

4.3 Safe Emptying of Latrines

Some latrines will have to be safely emptied periodically. These include latrines that do not completely transport away excreta (e.g. piped sewage systems), do not compost excreta into material that is safe to handle, or cannot be covered with soil and moved to a new pit.

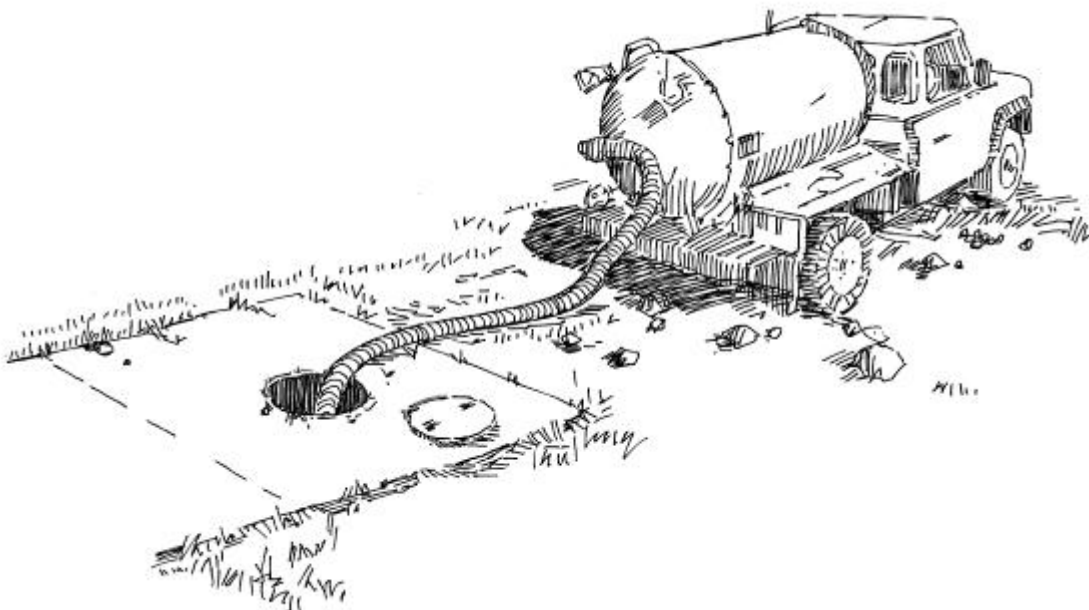

Emptying a septic tank (Credit: Shaw, 2005)

Emptying latrines has been a dirty job for centuries and is still common practice in many parts of the world. It is especially common in densely populated urban settlements where households do not have piped sewer systems or the space to build a new latrine.

Manual emptying and unsafe disposal of pit contents is the norm, a practice which puts labourers, householders and the neighbouring community at risk. Latrine pits are often very small--with storage capacity as little as 100-200 litres--and may require emptying every few months.

Latrines that need to be emptied should be lined to prevent collapse. The lining should be permeable to allow the infiltration of liquids into the soil. This can be done by using bricks or blocks, where liquids can seep out of the pit through the cracks.

Latrine emptying can be made safer for labourers, households, neighbouring communities and the environment. One approach is to encourage the use of twin pit latrines that allow excreta to be stored long enough for decomposition and pathogen die-off to take place. This, however, requires space and requires that households invest in something from which they may see no direct benefit.

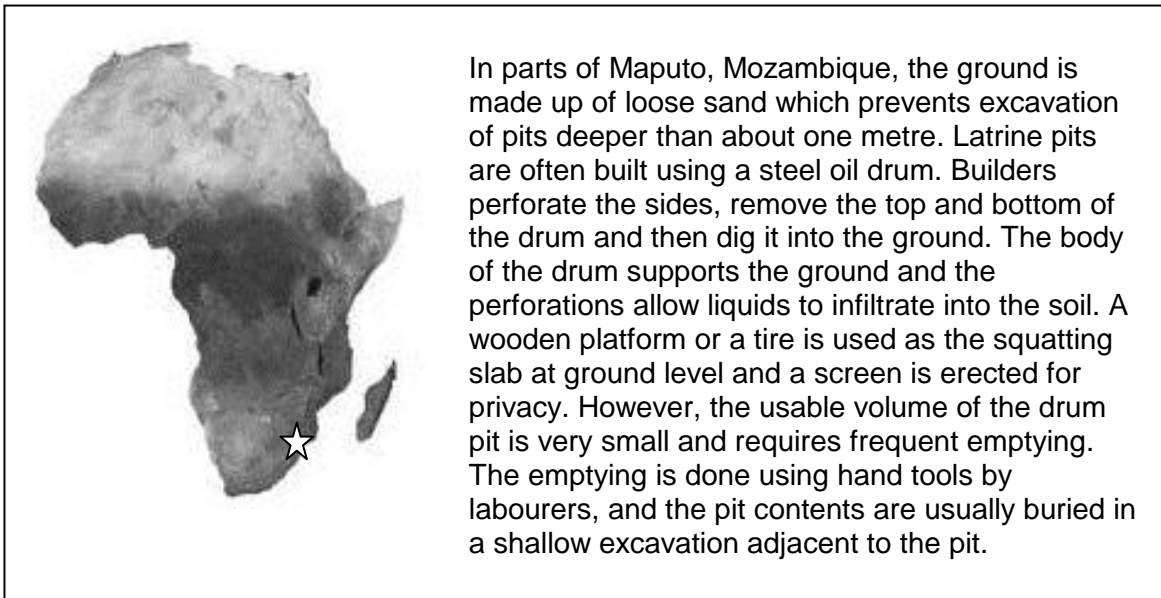

Alternatively, the latrine emptying process can be partly or fully mechanized. Mechanized emptying protects workers by reducing the need to handle pit contents but increases the cost paid by the households. The contents can be pumped straight into a tank for transport and disposal. Pumps can be manually operated or powered by electric motors or petrol/diesel engines. Mechanized emptying may also require space for pumps, wagons or trucks to access the latrine which may be difficult in some peri-urban conditions.

A sanitary method of transporting the excreta must also be arranged. It is possible to use a temporary storage tank and then transport the waste to a disposal site when

convenient. The best option is to empty the temporary storage tank into a sewage treatment plant which can deal with large loads of pathogen filled sewage. Emptying--or discharging--into a main sewer line is another option. In both cases, a binding agreement with the local authority responsible for the sewage network must be made.

Small Vacuum Tanker

The VacuTug is a small machine developed by UN Habitat which is capable of passing along the narrow pathways in unplanned urban settlements where a conventional vacuum tanker truck would not be able to pass. It has a vacuum pump, a storage tank and a drive system. It has been tested in a number of countries including India and Mozambique but has not yet passed to a scaling up phase. The machines are too expensive to be adopted by micro-entrepreneurs.

When planning to upgrade and improve latrine emptying services, efforts should be made to incorporate and employ the people already working in the business.

If mechanized systems cannot be used to empty latrines when required, care should be taken that labourers--or the householders doing the work--understand the health risks of handling unsanitary excreta and take appropriate precautions.

1. Gloves, boots, protective clothing and masks should be worn, and hands should be thoroughly washed afterwards. Washing facilities should be located near the pit.
2. No one should enter a pit without a harness and safety rope. There should be two people holding the rope who can pull the pit entrant out if they are overcome by fumes or if the pit walls collapse.
3. At least part of the pit cover and/or slab will have to be removed to allow access and improve air circulation.
4. The pit should be allowed to vent for a while after removing the cover/slab and before anyone enters the pit or begins work. This is done to let built up fumes escape and fresh air to enter.
5. The excreta must be properly disposed of to prevent any potential contact with humans or animals (e.g. by properly burying and covering with soil, or by discharging to a sewer).

(Reed et al, 2006)

4.4 Designing for Children and Schools

Latrines can be scary places for children. They are often dark and large and the child usually has to enter the latrine alone. It is therefore not a surprise to find children's excreta on the ground outside latrines.

The following is a list of suggestions to make latrines more child friendly:

- Make sure there is good ventilation to reduce smells
- Make sure there is good light (windows or electric) to reduce the darkness inside the latrine (VIP latrines should not have light)
- Consider some kind of night lighting (VIP latrines should not have light).

You may also consider building separate child friendly latrines, especially in a school setting, that have the following features:

- Low superstructure wall (1 metre high)
- Labyrinth entry (no door)
- Grab handles to hold onto while learning to squat
- Smaller seats and/or smaller drop holes
- Enough space for an adult to assist the child as necessary

Hand washing facilities must also be designed and built to be used by children. This can be done by placing the tap and/or wash basin at a height that children can reach or by having steps or a foot stool available.

In many parts of the world, the excreta of babies and young children is thought to be harmless. However, children's excreta is commonly more dangerous than adults. This is because the level of excreta-related infections among children is often higher and children lack antibodies. The excreta of infants can spread disease to others! The excreta of infants and small children should be cleaned up and disposed of in the latrine, not cast away into the bush or with the household rubbish.



Sanitation and hand-washing facilities do not exist in many schools around the world. There are a number of reasons why it is important to have child friendly, well-maintained facilities in schools:

- Improved child health
- Improved learning ability and environment
- An example that children can take back to their homes
- Encouragement for students to stay in school throughout adolescence, especially girls
- Convenience, safety and comfort of students and teachers

The needs of older girl students (about age 10+) must be considered in latrine design. Private facilities should be available to allow them to change, wash and dry menstrual cloths and dispose of sanitary products.

Ideally, one latrine should also be accessible to disabled students.

Teachers must be well trained in latrine use, latrine maintenance and hand washing. Teachers must use the facilities properly themselves in order to be examples to the students. Teachers sometimes prefer their own facilities at the school. There are reported cases of teachers locking student facilities to keep the student facilities clean enough to use. Installing teacher facilities may reduce the instances of this happening.

How Many Latrines?

- One per 25 girls
- One for female staff
- One toilet plus one urinal (or 50 cm of urinal wall) per 50 boys
- One for male staff

(Adams et al., WHO, 2009)

Students should be involved in latrine maintenance. A rotating schedule can be used so that all students have a chance to clean the latrines and keep the hand washing station stocked with water and soap or ash. Latrine maintenance should be supervised by a responsible teacher who is diligent and enthusiastic about the work.

Sanitation and hygiene education should be incorporated into the school curriculum. It can also be incorporated into extracurricular activities through student latrine maintenance programs, hand washing demonstrations, personal hygiene spot-checks

(e.g. teachers checking to see if students' hands are clean, nails are cut, teeth brushed), out-of-classroom sanitation and hygiene talks, guest speakers and sanitation clubs.

Schools may not have funding readily available for sanitation, latrine building, soap and educational materials. Fundraising can be done for these purposes and CAWST materials can be used for free for education purposes. Parents and students may contribute money or labour to build sanitation facilities. Government or other grants may be available for school sanitation and hygiene purposes.

What can we do?

National governments can invest in sanitation in schools; pay to train teachers to deliver effective hygiene education; create incentives for schools to invest in their own sanitation projects; fund national education and awareness campaigns aimed at children and young people; and create legislation that mandates schools to provide separate toilet facilities for boys and girls.

District/local governments can invest in sanitation in schools; find ways to use the expertise of health and infrastructure professionals in the education department; and create incentives for schools and teachers to improve sanitation access or deliver effective hygiene promotion.

Communities and civil society can actively support schools in their efforts to improve sanitation and hygiene; campaign for more public funds for sanitation and hygiene promotion; create connections between social organizations that focus on youth and those that focus on health; and endorse and further reinforce hygiene messages delivered in schools.

Households can lobby schools for better sanitation facilities and hygiene education; keep their children in school (both boys and girls); use good sanitation and hygiene practices in the homes; and find ways of raising resources to support schools in this effort.

Entrepreneurs can provide free or subsidized services in schools in their own communities (this will not only have a direct positive impact on children's health, it will also increase demand for sanitation in the house); and endorse and reinforce hygiene messages delivered in schools.

(WHO, 2004)

4.5 Designing for Special Needs Users

Latrine designs may have to take into account the needs of users with disabilities. This can include people in wheelchairs, with mobility challenges, with visual impairment and other challenges.

The path that leads to the latrine should have the following features:

- A firm, smooth, dry surface
- A width wide enough for a wheelchair; typical width is 1.2 metres
- Railings to assist with stability and to guide visually impaired persons
- If a ramp is required, it should be gently sloping and have a flat space in front of the door to allow a person in a wheelchair to back up and open the door

Access Path Slopes and Recommended Lengths for Independent Mobility

Type	Slope (Rise over Run)	Maximum Length of Slope (metres)	Comments
Very gentle slope	1:20 (5%)	10	Ideal slope
Gentle slope	1:15 (6.6%)	5	Possible for average wheelchair users. 1:15 or gentler slope recommended for public buildings.
Fairly steep slope	1:12 (8%)	3	Possible for riders with strong arms. Maximum recommended slope for independent mobility.
Very steep slope	1:10 (12% or more)	1	Not recommended for independent mobility. May be dangerous, as wheelchair may tip backwards.

(Lifewater International, 2009)

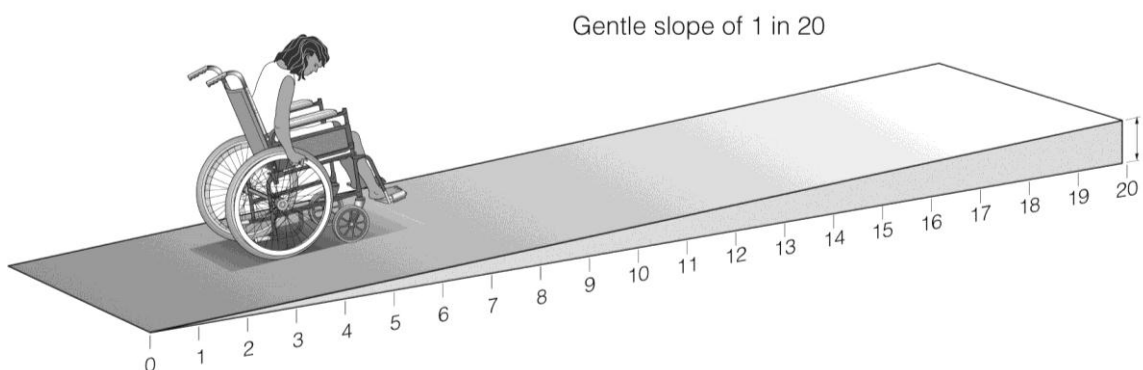

(Credit: Chatterton, WEDC)

The entry to the latrine should take the following into consideration:

- Door should be easy to open from a wheelchair (low handle and light enough to be easily pulled closed and pushed open)
- Latch and lock should be low enough to reach and easy to use
- A labyrinth entry may be more appropriate than a door

The design of the inside of the latrine should have the following features:

- Space should be big enough for wheelchairs to turn around
- Floors should be smooth and provide grip
- Raised seats for sitting can be easier to use than squatting
- Hand rails should be located inside for users to help support themselves

(Adapted from Lifewater International 2009)

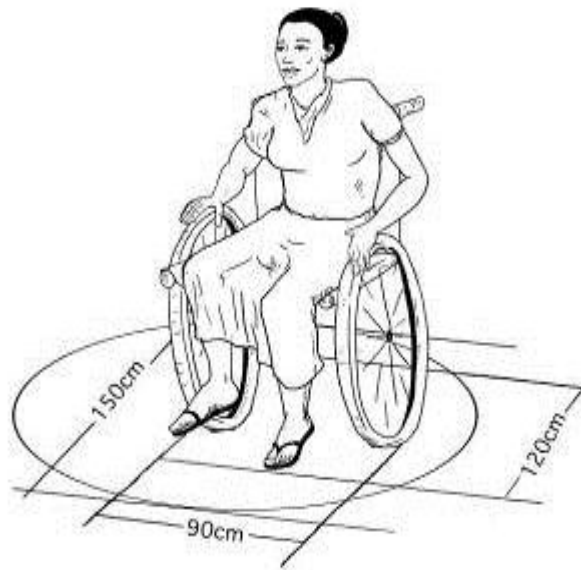

Space allowance for wheelchairs (Lifewater International, 2009)

4.6 Feminine Hygiene Considerations

Feminine or menstrual hygiene is an important aspect of sanitation that is often neglected. It can be a taboo topic that causes shame and embarrassment and in many cultures women do not even discuss it amongst themselves. There may also be superstitious beliefs about the sacredness of blood, or the dirtiness of blood. Among boys and men, awareness is often low about the physiological process of menstruation and the associated needs of girls and women. It can be very difficult to get information about a community's common menstrual hygienic practices.

A lack of hygienic and affordable menstrual products causes many women worldwide to use cloths, saris, tissues or even leaves which, if not clean and dry, can lead to infection. Girls stop going to school because they are embarrassed and ashamed when there are no private spaces where they can change and wash menstrual cloths. Any program including menstrual hygiene must also consider waste management. Some sanitary products are re-usable and must be washed well and dried between uses. Disposable sanitary products that are biodegradable can be buried, composted or burned depending on facilities and local beliefs. Non-biodegradable products must be either land-filled or burned.

Girls and women require a supportive environment where they can take care of their menstrual needs in private. This includes:

- Washing facilities with water supply, soap and drainage for washing cloths and pads
- A private drying area to fully dry the materials between uses
- A discreet and convenient place to dispose of soiled materials within the latrine/washroom. Disposal can be done by wrapping the soiled materials in tissue and placing it in a bin (then taken to a solid waste collection location), burning it or burying it. Soiled materials are often flushed or dropped down latrine pits which can cause systems to plug and/or fill up more quickly.
- Access to affordable sanitary products
- Access to environmentally friendly, biodegradable sanitary products
- Support from teachers, friends, parents and husbands

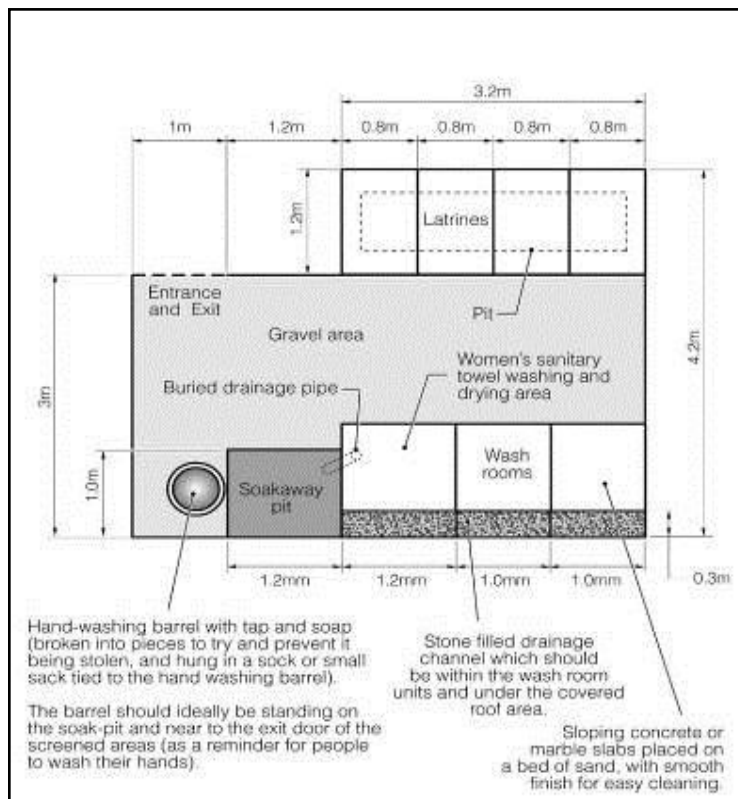

Example of a public latrine design with feminine hygiene facilities (Chatterton, nd)

Feminine Hygiene in Ghana

A new study into the impact of the provision of sanitary pads for girls in developing countries shows significant educational and social benefits.

Professor Linda Scott of Saïd Business School is leading a research project in Ghana to find out whether providing sanitary products in developing countries may offer a faster and less expensive way to raise school attendance and performance among girls than the more common community engagement programs aimed at keeping girls in school. Though the international aid community has thought about the potentially positive effects of providing sanitary products, this is the first time the effects have been studied.

The first phase of the study showed that girls of menstruating age were missing as many as five school days each month because there were no proper, private facilities where they could care for themselves. Other activities such as work, chores and playing with other children were also restricted. In rural areas the impact of menstruation on the girls was particularly noticeable where there were no, or inadequate, toilet or washing facilities, no privacy, and the girls had to walk two hours or more to school.

The second phase tested a combination of sanitary pads and education about menstruation and hygiene. After six months, the girls who received pads missed significantly less school than before the test. On average, girls who missed 21% of school days before pads missed about 9% of school days after pads. Girls in the village that only received education and didn't receive pads also missed less school, but the effect was delayed.

The girls also reported an improved ability to concentrate in school, higher confidence levels and increased participation in everyday activities while menstruating. They also reported fewer negative experiences like soiling and embarrassment, shame and isolation.

(Saïd Business School, University of Oxford, 2010)

4.7 Further Information

Feminine Hygiene:

Ten, V. (2007). Menstrual Hygiene: A Neglected Condition for the Achievement of Several Millennium Development Goals. Produced by Europe External Policy Advisors (EEPA). Available online at:

www.eepa.be/wcm/component/option,com_remository/func,startdown/id,26/

United Nations Children's Fund (2008). Sharing Simple Facts: Useful Information about Menstrual Health and Hygiene. New Delhi, India, UNICEF. Available at:

www.irc.nl/docsearch/search

Designing for Children and Schools:

<http://www.schoolsanitation.org/>

<http://www.schools.watsan.net/>

<http://www.irc.nl/page/114> - WASH in Schools page

Reed, B. and R. Shaw. (2008) Sanitation for Primary Schools in Africa. WEDC, Loughborough University, UK. Available at:

<http://wedc.lboro.ac.uk/publications/details.php?book=978-1-84380-127-6&keyword=&subject=0&sort=TITLE>

UNICEF and IRC. (2007) Towards Effective Programming for WASH in Schools: A Manual on Scaling Up Programmes for Water, Sanitation and Hygiene in schools. Available online at: www.unicef.org/wash/index_documents.html

5 Excreta Management Options

It is important to remember that behaviour change takes time. It can be a large accomplishment for a community to make even one improvement from open defecation. However, to protect and improve the health of the community, excreta must be managed while behaviour change is taking place. For this reason, excreta management options--including those categorized by the WHO/UNICEF JMP as unimproved--will be discussed in this section. More details about the function of each option can be found in the Fact Sheets provided in Appendix 1. Information about designing the pits is found in Appendix 2 and information about construction techniques is found in Appendix 4.

5.1 Open Defecation

Open defecation scatters human excreta in and near to the living environment where children, adults, animals, rodents and insects may come in contact with it. The risk of contamination and disease transmission is very high, especially in crowded living conditions.

In some circumstances, open defecation can have a lower risk. For example, in a hot and dry climate, excreta will dry out quickly and pathogens will die off, or in a region where population density is very low there is less chance that people will come into contact with excreta. In the case of nomadic or semi-nomadic pastoralists, the construction of permanent latrines may not be appropriate, and the risk of disease transmission due to open defecation may be low. In low-risk conditions, improved open defecation should be practiced as a minimum.

There are two common practices used to improve open defecation:

1. Cat scrape latrine
2. Bucket latrine/nightsoil collection

5.1.1 Cat Scrape Latrine

A cat scrape latrine is the simple process of digging a shallow hole, defecating in it and then burying the excreta. This method requires only a tool for digging the hole, such as a shovel, hoe or machete.

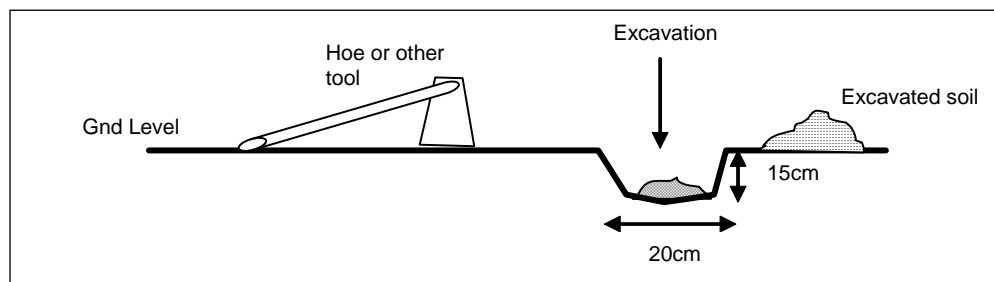

Cat Latrine / Scrape Latrine

5.1.2 *Bucket Latrine/Nightsoil Collection*

Nightsoil collection is the practice of storing excreta in small containers which are collected and emptied usually once or twice a week. Before regular plumbing and sewage treatment facilities were built, this was a common method of dealing with excreta disposal in many countries including the United Kingdom, New Zealand and Australia. Bucket latrines/nightsoil collection can still be found in rural areas with high water tables or other difficult ground conditions.

This type of system can run safely and effectively if it is properly managed and maintained. However, it can be expensive and requires many collectors and reliable transportation. The system can fail if it cannot easily and quickly adapt to a sudden rise in population or change in the environment.

Emptying the buckets and removing waste can be a service provided by the local government or by a private business.

Personal maintenance of this system is also necessary. The area around and behind the bucket must be kept clean. It is important to state whether the household or the collector is responsible for keeping this area clean. A collector will most likely be less motivated to clean up the bucket area than the people living in the home. The bucket must also be kept in good condition.



Bucket latrine showing bucket (Credit: Shaw, 2005)

Nightsoil collectors handle large amounts of fresh excreta and this profession carries a high risk of infection.

(Adapted from Merlin, 2002)

5.2 Pit Latrine Options

A pit latrine is the most basic type of latrine and is considered an improved sanitation option by WHO/UNICEF JMP. Excreta is deposited and contained in an inaccessible pit which prevents human contact with the excreta and contamination of the living environment. When the pit is full it can be emptied or covered and the superstructure moved to a newly dug pit. It is important to line the pit for safety if it is going to be emptied. A well designed and constructed pit latrine can be a very effective and safe method of disposing of excreta.

There are different options for a pit latrine design depending on the user's needs, preferences and resources. Pit latrines can be used for both washers and wipers, do not require water and can be cheap.

The following types of pit latrines will be discussed briefly in this section (see Appendix 1 for Fact Sheets that provide further details on design and operation):

- Simple pit latrine
- Ventilated improved pit (VIP) latrine
- Pour flush latrine
- Twin pit latrine

5.2.1 Simple Pit Latrine

The simple pit latrine is found almost everywhere in the world. It is a pit dug into the ground, covered with a slab with a drop hole in it, and usually has some sort of structure around it for privacy. Smells, flies and other vectors will be reduced if the simple pit latrine is well maintained, the slab is kept clean and the hole is kept covered.

The latrine's components can be made out of local materials such as wood, brick, metal, thatch or concrete.

5.2.2 Ventilated Improved Pit Latrine

The ventilated improved pit (VIP) latrine is an improved version of the simple pit latrine. The main differences are:

- **A ventilation pipe is incorporated.** Fresh air flows into the superstructure through a vent that can be made from plastic, concrete or brick. The air travels through the drop hole and the smelly air and gases from the pit are drawn out through the vent pipe. The pipe is covered at the top with a fine mesh (often mosquito mesh) to prevent flies and other insects that may be attracted by the smell from entering the pit.
- **The superstructure is built so that it is always dark inside.** Flies that do get in the pit by coming in through the vent or door will be attracted to the light at the top of the vent pipe but will get stuck in the mesh and die.
- **The drop hole is not covered.** It needs to stay open so that the air can flow into the pit and then up and out of the vent.

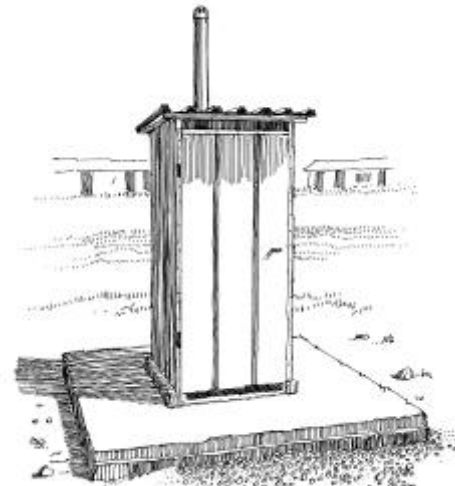

VIP Latrine (Credit: Shaw, WEDC)

5.2.3 Pour Flush Pit Latrine

A pour flush latrine is a version of the simple pit latrine that requires water to move excreta into the pit. A pour flush pan is built into the slab and is used instead of a drop hole.

The pan is designed so that there is a water seal created in the pipe. This stops smells from escaping from the pit and flies and rodents from entering the pit. Well designed, smooth pour flush pans require as little as 2-3 litres to flush; however inefficient pans may need 5-6 litres to flush properly. Pour flush pans can be made from concrete, ceramics, plastics or enamelled steel. Plastic pans tend to be cheapest as they are quite smooth and easy to clean, but they are often less robust than other materials.



Pour flush latrine (Credit: Shaw, WEDC)

The pit can be offset from the superstructure with a short section of pipe or covered channel connecting it to the pour flush pan. This allows simpler and lighter slabs to be used to cover the pit. It also means that the superstructure can be built out of heavier materials such as brick and block because it will be better supported by the earth.

Pour flush latrines are particularly appropriate for people who use water for anal cleansing. Soft wiping materials (e.g. toilet paper) can be flushed, but those who use solid materials will need a separate sanitary method for disposing of the soiled material.

5.2.4 Twin-Pit Latrines

The twin-pit latrine is made of two lined pits dug side by side. When one pit is full, the other pit is then used. When the second pit is full, the first pit is emptied and re-used. The pits are lined to stop them from caving in when they are emptied. The type of latrine used with twin-pits can be a simple pit, VIP, or a pour flush latrine. Composting and dehydrating latrines also use a twin pit system, but they require special operation that will be discussed further in the ecological sanitation section.

A twin-pit latrine is used where it is necessary to empty latrines and dispose of the contents elsewhere once they are full. This includes places where there is limited space or where more permanent structures are desired. The pits should be sized so that each pit fills up over the course of one or two years. This way the pit contents can sit while the other pit fills up. A two year period is recommended in most climates for the pit contents to decompose and for the pathogens to die off. The pit contents can then be removed safely (WHO, 2006).

It is also possible to build a twin-pit latrine above the ground by making a double vault. Users walk up a set of stairs or ramp to use the latrine. A trap door should be installed in each vault so that waste can be shovelled out.

The main objective with a twin pit latrine is to make emptying the latrine safer for those doing it. With proper operation it can also produce a good quality compost material for eventual use as an agricultural soil conditioner or fertilizer (see section 5.3 – Ecological Sanitation for Excreta Disposal)

5.3 Ecological Sanitation for Excreta Disposal

Ecological sanitation (ecosanitation) is based on the idea that excreta is a resource. Decomposed excreta (also known as compost or ecomumus) is rich in nutrients (nitrogen, phosphorous, and potassium) and organic material. The organic material acts as a soil conditioner, improves the structure and water holding capacity of sandy soils and adds structure and permeability to clay soils. Composted excreta, on its own or combined with other biodegradable material, enhances the fertility of topsoil (Akvopedia, 2009). The use of human excreta in agriculture is not new technology; it has a long history in Asia.

The ecosanitation approach and use of human excreta in agriculture is promoted as an appropriate technology for developing countries because it addresses the need for:

- Increased food production
- Reduced chemical fertilizers
- Safe disposal of excreta
- Reduced environmental pollution

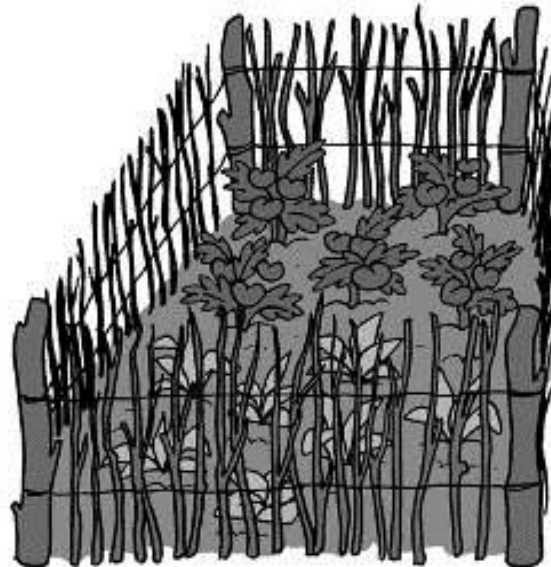

Feces may contain high amounts of pathogens and must be treated appropriately to make sure it is safe to use (WHO, 2006). The objectives of ecosanitation are to:

- 1) Reduce the pathogens found in excreta to safe levels
- 2) Turn it into plant-available nutrients and a rich soil conditioner.

Treating excreta and using it as an agricultural resource makes environmental and economic sense. To be successful, though, careful attention must be paid to safety throughout the whole process. Using excreta that has not been properly treated will increase health risks to people involved in ecosanitation.

Health Risk Management in Ecosanitation

Handling or using excreta must not pose a significant risk to people's health. Whatever method used, it must be designed and properly operated to reduce health risks from pathogens. The health risk involved depends on how well the excreta is composted before being removed from the latrine, and how safely the emptying and application of excreta are carried out. There are three times a person can become infected by pathogens while handling excreta:

- Direct contact and infection while emptying the pit and applying excreta to the land
- Direct contact and infection while applying excreta to the land (e.g. children or adults working the fields)
- Indirect contact while eating contaminated crops, especially those that are not cooked before eating

The following table shows how long common fecal pathogens can survive in soil and on crops at 20-30°C.

Survival of Various Pathogens in Soil and on Crops

Common Pathogen	Survival Time in Soil (days)	Survival Time on Crops (days)
Bacteria: Thermotolerant coliforms	<70 but usually <20	<30, but usually <15
Virus: Enteroviruses	<100, but usually <20	<60, but usually <15
Helminths: <i>Ascaris</i> and tapeworm eggs	Several months	<60, but usually <30

(Adapted from WHO, 2006)

The overall risk associated with different kinds of ecological sanitation can be assessed using the figures in the above table, the ideal conditions for killing pathogens, and the characteristics of different ecosanitation options in different settings.

Overall Risk Associated with Different Ecosanitation Options

Type of latrine and practice	Risk of pathogen survival in pit / vault	Post-latrine risk	Overall risk
Well managed dehydrating latrine (with urine diversion), with 12 month storage			
Peri-urban area growing maize on a plot 25 metres from any house. Contents dug into the land before planting.	Medium	Medium	Medium
Rural area growing maize in an isolated part of the village. Contents dug into the land.	Medium	Low	Low
Composting latrine (without urine diversion)			
Urban garden in a high density area growing tomatoes on a small plot of land. Contents dug into the land before planting.	High	Medium	High
Rural area growing maize in an isolated part of the village. Contents dug into the land before planting.	High	Low	Medium
Single pit arborloo			
Urban garden growing banana trees on full latrine pits. Pit is first covered with 25 cm of soil.	Low	Low	Low

(Scott, 2007)

The major factors that contribute to pathogen reduction for different ecosanitation options are shown in the following table.

Ecosanitation Options	Significant Form of Pathogen Reduction
<ul style="list-style-type: none"> Composting latrine (without urine diversion) 	<ul style="list-style-type: none"> Storage time and predation
<ul style="list-style-type: none"> Dehydrating latrine (with urine diversion) 	<ul style="list-style-type: none"> Storage time, low moisture content and high pH
<ul style="list-style-type: none"> Single pit Arborloo 	<ul style="list-style-type: none"> Isolation of excreta, storage time and predation
<ul style="list-style-type: none"> Biogas digester 	<ul style="list-style-type: none"> Storage time, digestion

(Adapted from Scott, 2007)

Ecosanitation relies on storage time, increased temperature, increased pH levels, and a low moisture content to kill the pathogens. The following factors have a positive effect on reducing pathogens:

- Increased storage time – The longer the better.
- Reduced moisture content – To allow decomposition in the presence of air, the pit contents in composting latrines should be kept as dry as possible.
- Increased pH of the contents – The higher the better, but a pH that is too high can harm the decomposition process. This is more important in dehydrating latrines than in composting latrines.
- Increased temperature of the contents – Excreta produces heat as it decomposes. The system should be designed to trap the heat. Some systems are designed to also absorb solar heat.



In a **composting latrine** the main factor for pathogen destruction is **storage time**. Moisture content, pH and temperature are secondary factors. Even in a well-managed composting latrine the moisture content is not low enough to dry out the pathogens, the temperature is not high enough to destroy them and the pH does not achieve the correct levels if soil and ash are added.



In a **dehydrating latrine**, the main factor for pathogen destruction is **storage time**. The pH may reach relatively high levels (above 9), but the temperature and moisture content rarely reach the levels required to have a significant impact. In warm, humid climates, achieving the correct (low) moisture content becomes almost impossible

For sufficient pathogen removal, latrine contents should be stored at a minimum of 20°C for 1.5 to 2 years (WHO, 2006). At higher temperatures, the storage time may be reduced to one year. Alternatively, there are other treatments that will help reduce pathogens in excreta such as:

- Properly managed thermal composting at over 50°C for at least 7 days (WHO, 2006)
- Adding urea, ash or lime to raise the pH above 9 for at least 6 months

Composted excreta can be removed and applied to the land with the exception of the excreta collected in the arborloo. Composted excreta should be worked into the soil and should not be used on fruit, vegetables or roots that will not be cooked before they are eaten. A period of at least one month between application and harvest is recommended both for urine and for treated feces. During this month, microbial activity in the soil, UV radiation from the sun and drying from the heat reduce the risk of pathogens. This one month period also is needed for the crops to utilize the nutrients (WHO, 2006; Stockholm Environment Institute, 2008).

Laws and regulations meant to protect excreta handlers will vary according to the socio-cultural, economic and environmental circumstances found in each situation. In practice, however, health protection measures can be taken to reduce potential health risks even in low income settings (WHO, 2006). As a minimum, handlers should wear gloves and should wash their hands frequently.

Suitability of Ecosanitation

Situations where ecological sanitation is suitable include:

- Regions where an assessment indicates a very low level of overall risk (e.g. correctly using an Arborloo)
- Regions where open defecation is widely practiced
- Regions where there is already a demand for the compost produced
- Institutions where good facility management and protection from human contact with excreta can be guaranteed
- Regions with traditional latrines where the community already practices safe post-latrine excreta handling, ie. enough storage time, limited human contact and good crop selection

There may be situations where ecosanitation is not appropriate, such as:

- Regions where there is high coverage of traditional latrines
- Regions where there are no issues regarding ground water contamination
- Regions where there are no opportunities to use excreta as compost
- Regions where using excreta for this purpose is not acceptable or is against religious and local beliefs

Ecosanitation Latrines

Composting latrines are constructed and operated to convert excreta into a safe compost material as quickly as possible. Nevertheless, composted excreta should be handled carefully to reduce any health risks. The pathogens that make composted excreta risky will only die off if the latrine is operated correctly.

5.3.1 Composting Latrine (Without Urine Diversion)

A composting latrine is very similar to a twin pit latrine but with slight differences in the way they are operated. Both pits must be lined for safety because they will be emptied, similar to the twin pit system. Users may choose to build a double vault above the ground instead of two pits. An access door should be installed in each vault so the composted excreta can be shovelled out. The compost should sit for about two years at a temperature of 25-30°C whether it is in a pit or a vault. In colder climates this time will be longer. The end product will be compost with good quantities of nitrogen which comes from the urine.

The process of decomposition in this latrine relies on the amount of time the excreta sits before being used as fertilizer. The longer it sits, the better and safer the product will be. The process also relies on pathogens eating each other (predation), so the environment inside the latrine must be warm and slightly damp, and it must contain oxygen to allow the pathogens to live. Ash, straw or other materials high in carbon content should be added to the pit after each use to help decomposition.

Wash water from anal cleansing should not be put down the pit. It should be put into another sanitary disposal system such as a soak pit. Too much moisture will drown the pathogens and slow the rate of decomposition. Soft, degradable wiping material can be put in the pit.

Not being able to pour water down the pit and having to move to another location to wash may make this latrine less attractive to a community. This should be considered when planning a project where the norm is to cleanse with water.

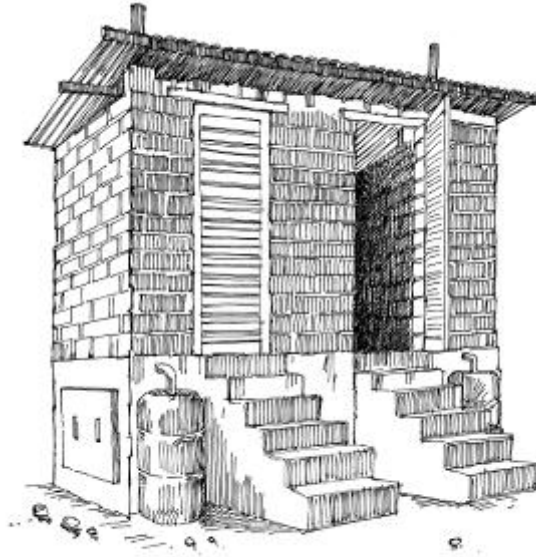

Composting Latrine (Credit: Shaw, WEDC)

5.3.2 Dehydrating Latrine (With Urine Diversion)

A dehydrating latrine is similar to a composting latrine with slight differences in the operation and product produced. The main difference is that urine and wash water are **not** put down the pit. The latrine operates with a twin pit system where both pits must be lined for safety because they will be emptied. Users may choose to build a double vault above the ground instead of two pits. An access door should be installed in each vault so the dehydrated excreta can be shovelled out. The excreta should sit for about two years at a temperature of 25-30°C whether it is in a pit or a vault. In colder climates this time will be longer. The dehydrated product is applied to the soil as a conditioner which brings strength, water retention and some nutrients to the soil.

There must be a separate collection system for urine so that it does not enter the main pit. It is collected and used directly as fertilizer. Toilet paper and other wiping materials should not be disposed of in the pit. Wiping materials must be safely and hygienically disposed of, for example, they can be buried in a separate waste pit or burned.

Urine as a Fertilizer



(Credit: Akvo.org)

Most of the nutrients for fertilizer are found in urine while most of the pathogens are found in feces. Urine is generally sterile from a healthy individual, so it can be used as a fertilizer on home gardens without any specific processing. It is recommended that at least one month be left between the last application of untreated urine and harvest. Urine should be stored for one to six months if it is being applied to crops that will be sold or consumed outside the home, and longer if the urine might be highly contaminated. Urine should be stored undiluted and in a covered container to prevent loss of nitrogen.

Urine should be applied close to the soil to avoid splashing which can cause crop-burn. It can be added into the soil by turning the soil or by dousing the soil with water after adding the urine. It is possible to divert and collect urine using any conventional latrine

The process of dehydration relies primarily on the amount of time the product sits before being used as soil conditioner. The longer the time, the better and safer the product will be. The process also relies on having dry conditions (less than 25% moisture content), oxygen and a high pH inside the latrine. In order to produce this environment, latrine users can add lime, urea plant (wood) ash, rice husks, coal ash, saw dust, loess or shell sand to the latrine and must keep all liquids out of the latrine. This is also the reason why urine should not go into the pit. If the users are anal cleansers, the wash water should not be washed into the pit or into the urine storage container.

Similar to composting latrines, not being able to pour water down the pit and having to move over to another location to wash may make this latrine less attractive to a community. This should be considered when planning a project where the norm is to cleanse with water.

5.3.3 Arborloo

The Arborloo is a simple and easy approach to using human excreta as a resource with minimal health risk to the users or others. The pits are normally 1 m³ which will fill up in about six months. Once the pit is full, a new pit is excavated and the slab and superstructure are moved to the new pit. The full pit is then filled with soil and a tree or shrub is planted. Fruit or fuel wood trees are commonly planted.

This is appropriate in an urban or rural setting as long as the householders have sufficient land to move their latrine every 6 months and to plant a tree on each old site.



Arborloo (Credit: Akvo.org)

5.3.4 Biogas Digester

The biogas digester or generator uses the natural decomposition process to free methane (60%) and carbon dioxide gas (40%) from excreta and other organic matter. The gas produced is collected and stored in a chamber and can be used for cooking, cooling and lighting by using specially modified stoves and appliances.

A single family will not produce enough excreta to fuel a biogas digester. It is common to add the excreta from one or two cows (or a similar quantity) to the mix. A biogas digester should be designed based on the quantity of manure available rather than the size of the family. The biogas digester will also require about the same amount of water as it will require manure. Some communities may refuse to use human excreta in their biogas digester but may be happy to use animal excreta.

After the solids have been digested, the slurry that is left over can be composted to reduce the number of pathogens and to produce compost that can be applied to crops.

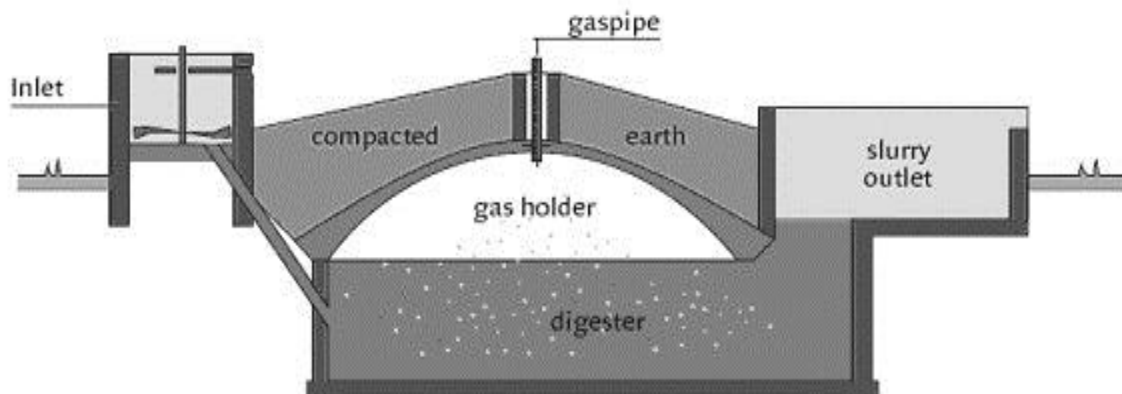

Biogas digester (Credit: Unknown)

5.4 Tank Options for Excreta Disposal

5.4.1 Aqua Privy

The aqua privy is basically a latrine constructed directly over a simple impermeable tank that is filled with water. The slab has a pan in it which is attached to a pipe that drops straight down into the tank. The pipe should be at least 75 mm below the water surface so that a water seal is created. The water seal will help reduce bad smells and flies. The tank for this latrine can be built above or below ground.

Very little water is required to flush the pan after use. The water used for anal cleansing may provide enough to flush solids from the pan.

This is a good option where pit latrines are either socially or technically inappropriate such as places with high water tables. It can also be used as a communal facility because it is easy to operate and maintain. The solids that accumulate in the tank should be emptied every few years by machine. Emptying it by hand is very difficult because of the level of water in the tank.

The wastewater that comes out of the tank through the outlet must be disposed of properly. This can be done using a soak pit or infiltration trench system.

5.4.2 Septic Tank

A septic tank is a large, watertight, usually underground tank where sewage is held long enough to let scum, fats and soap float to the water surface and for solids to settle to the bottom. The clarified water (water clear of scum and suspended solids) then flows to a soakaway or infiltration trench. A septic tank can be connected directly to a latrine. In this case, water will be needed to flush the contents into the pit. However, this water can be wastewater from other domestic activities such as bathing and washing dishes. The volume of the settled solids (sludge) is partly reduced by bacteria inside the sludge that will digest it. This digesting process releases gas, so a septic tank must always have empty space (free board) between the water and the top of the tank as well as a ventilation pipe to release the gases.

There are normally two or sometimes three compartments separated by baffle walls. The first compartment is sometimes called the grit chamber; this is where the largest and heaviest particles settle out. The second and third compartments allow more time and opportunity for smaller particles to settle out.

The septic tank will have to be visually checked regularly through the access cover to make sure it is operating properly. The sludge must be emptied periodically when it fills the tank. Vacuum trucks are usually used to empty septic tanks and to dispose of the solids in a safe location.

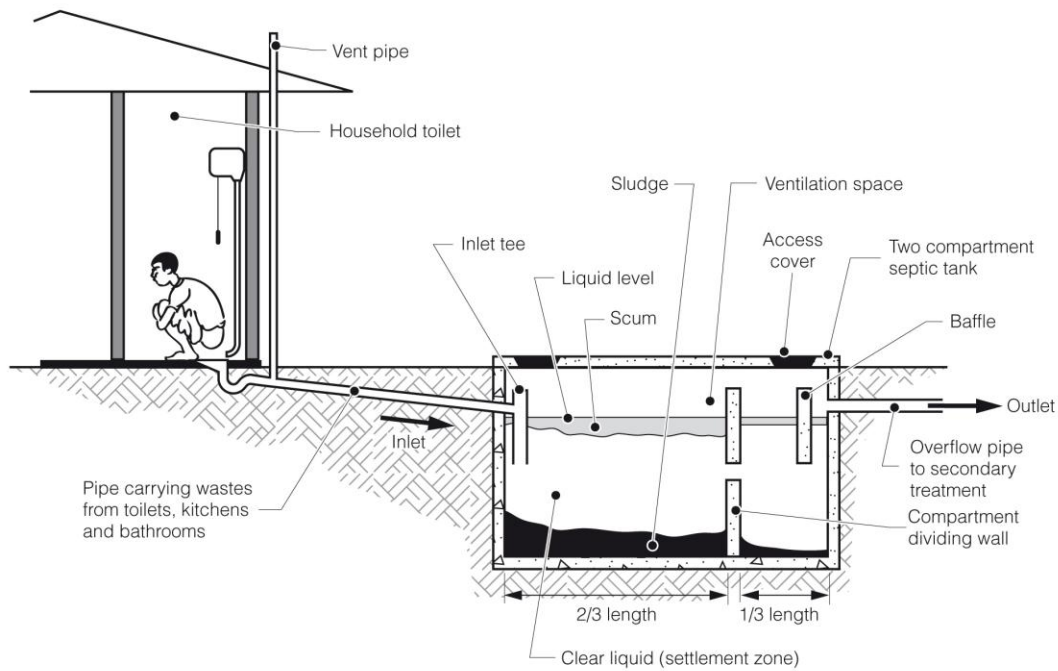

Septic tank system (Credit: Chatterton, WEDC)

5.4.3 Cess Pit

A cess pit is a sealed tank that is used to store household wastewater and sewage. It differs from a septic tank in that all the liquids are stored in the tank rather than being discharged or infiltrated. The cess pit must be emptied frequently, usually by a vacuum truck. Frequent emptying can become expensive and therefore this type of system is usually only appropriate where ground conditions or environmental concerns prevent the installation of a septic tank system.

In North America, the term cess pit is used to describe a leach pit where wastewater and sewage is discharged; liquids infiltrate into the ground and solids are retained. Cess pits are no longer recommended in North America as they are prone to clogging which can lead to overflow and flooding.

5.5 Low-Cost, Small Bore, Settled Sewage Systems

Conventional sewer systems used in urban areas are usually designed to carry both sewage, wastewater and rain water. They are often very expensive. Rain water can add very large flows to sewer systems so they must be designed to be able to handle occasional heavy rain storms. Because they are designed to handle large capacities of water, such systems are usually constructed along roadways where large amounts of water will runoff from the pavement. It is also advisable to construct them along roadways so that they are easy to map and are more easily accessible for maintenance.

Small bore sewage systems are different from conventional sewer systems in that they are not designed to carry rain water. Also, a large proportion of the solids they handle are settled in household tanks before wastewater enters the system. As a result, the

pipes and components can be much smaller and they can be laid at shallower gradients. Another advantage of these systems is that they can be laid along narrow lanes using small excavations and can be put into existing settlements with little disruption to the community.

Small bore settled sewage systems are an appropriate solution for urban, peri-urban and rural villages with high population densities, and where there is enough reliable water available for flushing. When the toilet is flushed the contents pass first through a settlement tank (essentially a mini-septic tank) where solids settle out. The wastewater then passes through small diameter pipes to collector pipes which lead to a treatment or disposal site.

The community and individual householders that use small bore sewer systems are commonly responsible for the construction, operation and maintenance of their latrines, settlement tanks, their household connection and the lane sewer. The government--or in some cases the community--is responsible for the main sewer line and the disposal or treatment plant.

5.6 Further Information

World Health Organization (2006). Guidelines for the Safe Use of Wastewater, Excreta and Grey Water World Health Organization, Geneva, Switzerland.

6 Excreta Disposal in Difficult Conditions

This section describes how to manage excreta in difficult conditions, including:

- Areas with difficult conditions due to water
 - Areas with high ground water tables
 - Areas prone to seasonal flooding
 - Floating communities or houses built over water
- Rocky ground that is difficult to dig to any depth
- Extreme space limitations
- Cold weather

6.1 Areas with Difficult Conditions Due to Water

High Ground Water Table

Practically speaking, it can be very difficult to dig a pit below the ground water table with basic hand tools. It is generally **recommended not to dig pits to less than 1.5 metres from the water table** in order to reduce the potential of groundwater contamination.

However, in many areas this can be very difficult to achieve because groundwater levels can be as high as 1 metre or less from the surface. Groundwater contamination is a serious issue where wells and shallow boreholes are used for drinking water. If ground water is brackish (high in salt content) and/or not used for drinking or domestic purposes, then a pit below the groundwater level could be considered.

Frequent Flooding

In areas that experience seasonal flooding, latrine design should be adapted to reduce the risk that they will flood. Flooded and overflowing latrines can contaminate the surrounding area. If the depth of the flood waters is shallow then a simple head wall around the top of the latrine will be enough to prevent flooding. If flood waters are high, raised vaults or composting latrines should be considered.

Drinking water sources should also be adapted to reduce the risk of contamination and to allow them to be used even after the area is flooded.

Communities Built On/Over Water

In areas close to water, some people live in dwellings that are built on stilts over water or they live on boats. In these circumstances, latrines and sanitation projects must be designed in ways that prevent human waste from contaminating surface water. Emptying or discharging latrines directly into the water may contaminate drinking water, contribute to algae and weed growth and reduce fish populations.

6.1.1 Solutions for Areas with Difficult Conditions Due to Water

Elevated Latrines

Elevated pit or vault latrines are a solution for high ground water levels flooding areas

Elevated Pit

The elevated pit functions in the same way as a simple pit latrine: excreta are stored in the pit and decompose over time. Liquids filter into the ground at the base of the pit and through the raised earth mound that surrounds the pit chamber.

It is important to make sure that the soil at the base of the pit and in the raised mound is porous enough to absorb the amount of liquid coming out from the pit. The soil under the mound should be dug and disturbed before building and compacting the earth mound. This helps to avoid channelling of liquids horizontally at the mound/soil junction (where the mound meets the soil).

Elevated composting latrines may be a better and safer option. In a composting latrine the pathogens in the excreta are destroyed by the composting process. There are less pathogens filtering into the ground and therefore less chance of groundwater contamination.

An elevated pit latrine should be excavated at the driest time of the year. This is when it will be the easiest to dig. Excavated materials can be used to build up the mound.

The pit lining can be made with rock, bricks, concrete blocks, concrete rings etc. The lining must be impermeable above the top of the mound and this impermeable layer must extend to 0.5m below the top of the mound. The remainder of the lining must be porous to allow the infiltration of liquids.

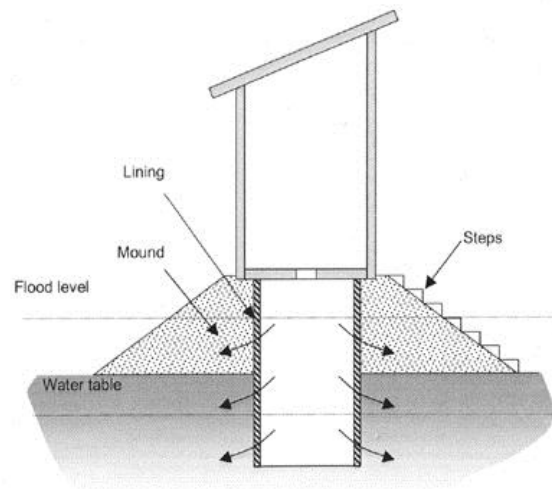

Elevated pit latrine (Credit: WELL)

Elevated Vault

An elevated vault latrine is essentially a masonry chamber constructed on the surface of the ground with the superstructure on top of it. Elevated vault latrines are designed to be emptied. When the vault is full it must be emptied (shovelled out or emptied by vacuum tanker) and the contents safely disposed.

Elevated latrines may not be the best solution for every community. They can be rejected in regions where people feel self-conscious about being observed while going to the latrine and they can be difficult for the elderly and disabled to use.

Cess Pit

These may be a solution for areas with frequent flooding or homes built over water. In a cess pit, the latrine tank is closed and it produces no discharge. When it fills up, it must be mechanically emptied and the contents disposed of by composting or burying.

Ecosan

Composting or urine-diverting dry toilets may be a solution for communities built on water. They can be used if they are built in closed containers and if they are built to a size that is appropriate for dwellings that exist on or over water.

Floating toilets for floating villages on Cambodia's Tonle Sap lake

The Singapore-based nongovernment organization, Lien Aid, has introduced floating toilets as part of its “River of life” project for the floating communities of Tonle Sap lake in Cambodia. In February 2009, Lien Aid was introducing “different toilet designs that they can build on their houseboats,” CEO Sahari Ani told the Asian Development Bank. “Simultaneously, we’re providing them with a safer choice for drinking water by building a floating water treatment plant,” Mr. Ani said. “We are exploring several options including the use of especially adapted septic tanks plus ecological sanitation using the urine diversion-dissecting (UDD) toilet.”

Based on the villagers’ preferences, Lien Aid “determined the size of the toilets, buckets to be used for storage of excreta, ecosan pans (2-hole or 3-hole), and other design considerations [resulting in] 3 workable designs to date. Our next challenges are to modify existing toilets to incorporate the UDD options, ensure availability of suitable drying material for covering feces, and keep the costs manageable,” Mr. Ani explained.

Lien Aid, which works together with the Ministry of Rural Development (MRD) and local authorities, “is developing simple [...] publications on methods of construction, use, and maintenance of the floating toilets.”

Floating toilets cost “between US\$50-200, depending on whether the family will just upgrade their existing drop-hole toilet to accommodate the UDD technology or whether the entire toilet, including superstructure, will be constructed from scratch. The size of the toilet will also dictate the cost--toilets that can accommodate two tanks will obviously cost more. The two tank toilets will be for families who wish to avoid handling semi-decomposed excreta every few months. Once the first vault is full, it can be sealed for a few months until the feces dries up, and the alternate second vault will be used. Toilets with only one vault means the family will have to dispose of semi-composted feces at monthly intervals. We’re still trying to lower the cost by using indigenous materials and encouraging local entrepreneurs to manufacture the UDD pans.”

Together with the floating toilets, “a land-based composting unit and collection system will be established to manage the semi-composted feces. We hope to promote the use of fully decomposed feces as compost.”

Lien Aid had “already set up a community center for water-sanitation related training and advocacy activities” and “will also form a water-sanitation group from among the residents and community leaders.”

(Adapted from Dueñas, 2009)

6.2 Rocky ground (Difficult Excavation)

In ground where it is difficult to dig, elevated vault latrines or ecosan solutions that do not require underground pits may be used.

6.3 Space Limitations

In many parts of the world, space limitations restrict the types of sanitation facilities that can be installed. This is often considered a problem in urban and peri-urban areas where space and land ownership restrictions can be extreme, but it can also be an issue in rural areas where land scarcity is an issue.

6.3.1 Solutions for Areas with Space Limitations

Regular Latrine Emptying

Building latrines that are designed to be regularly emptied are a good solution where there is no space to dig new latrines after the first one fills up. If there is sufficient space initially, twin pit or composting latrines are an option. However, in urban areas where space restrictions are most common, it is also less likely that the householder would have a use for compost, or that there would be a market for composted excreta. Nevertheless, the twin pit or composting approach would make the regular pit emptying and disposal process safer.

Low Cost Sewerage

Low cost shallow sewage systems can be constructed in unplanned and congested neighbourhoods. However, space is required for the construction of the toilet and settling tank in or next to the householder's plot of land. This system also requires water for flushing, a place where the wastewater can be discharged and a system for emptying the settling tanks. These systems were pioneered in Pakistan and have been successfully installed and operated in slum areas. They have also been installed in rural villages where the wastewater is used for irrigation.

Shared Latrines

Latrines shared between families--or communal latrine blocks--are an option where there is no possibility of constructing individual household latrines. Shared and communal latrines have been known to have operation and maintenance difficulties and they can be perceived badly by users. However, if the operation and maintenance are well planned and managed, then shared or communal latrines can be an appropriate option. Communal latrines are common in urban areas of China, Bangladesh, Indonesia, and many countries world-wide.

Key requirements for successful communal latrines are:

1. There must be permanent cleaners/caretakers who must be paid.
2. There must be a system to charge users a fee to cover the cost of upkeep and maintenance.
3. Hand washing stations with soap must be provided.
4. There must be a reliable source of water for flushing and hand washing.

Communal latrines should be carefully planned and built with full participation by the community members who will use the latrines. They must be located within easy, safe and convenient reach of all users. Security or a permanent attendant may be needed to prevent misuse of the latrine and abuse towards women inside the latrine.

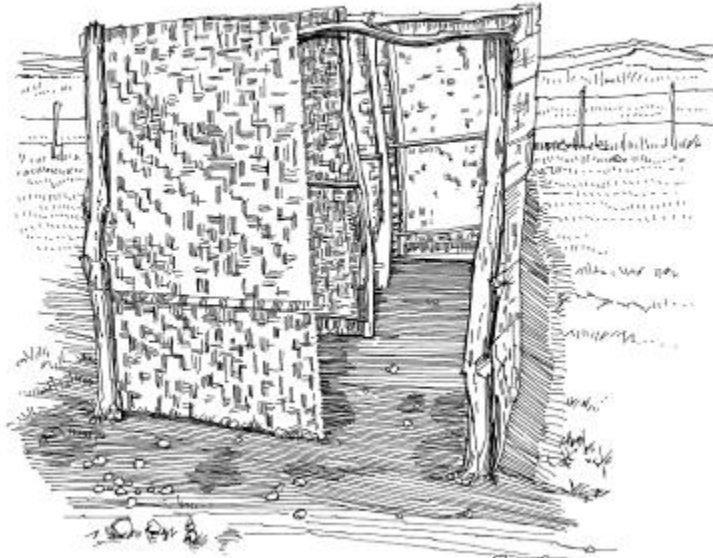

Communal latrines (Credit: Shaw, WEDC)

6.4 Cold Climate

There are different challenges associated with excreta disposal in cold climate countries than there are in warm climate countries. These differences should be taken into account when planning a new sanitation project to ensure that the latrine pit has been designed appropriately.

The biological processes which normally reduce the volume of sludge stop when the temperature drops below 0° Celsius (Buttle, 2001). When the temperature rises again, the processes will restart. This means that excreta will need to sit longer than the usually recommended two years before it is safe to handle. It also means that while designing the pit, the sludge accumulation rate and the volume of waste per person per year should be increased. This is because there will be less volume reduction from biological processes like predation.

In some countries the ground may be frozen and may be considered impermeable. Liquids from the pit will not infiltrate into the ground at these temperatures. The size of the pit will need to be increased to take into account extra liquid storage.

In very cold conditions where temperatures are less than -10° Celsius, the excreta falling into the pit may freeze very quickly and the pile will not slump (Buttle, 2001). If this happens the pit will fill up faster because there will be gaps between frozen excreta that will lead to uneven filling. Again, the sludge accumulation rate will have to be increased to take into account the volume of the voids.

Each latrine type will have its advantages and limitations in a cold climate situation. For example, the water seal in a pour flush latrine might freeze, or the vent pipe in a VIP

latrine will actually draw cold air into the latrine superstructure. Ecosanitation options such as a composting latrine will take longer to create a safe, usable fertilizer or soil conditioner. It is best to discuss each option with the community and/or user to find out which option is most suitable.

7 Domestic Wastewater Reuse and Disposal

Wastewater must be properly reused or disposed of to protect public health. Infiltrating domestic wastewater into the ground is often the best disposal method as long as the capacity of the ground can manage the quantity of water to be infiltrated. Wastewater can also be reused to irrigate a small garden or a larger agricultural crop if there is enough wastewater available.

Domestic wastewater is usually divided into the following two categories:

- **Black water** – Wastewater that has been used to flush a toilet or latrine and contains excreta (e.g. sewage). This water will have lots of pathogens in it
- **Grey water** – All other types of wastewater from domestic activities (e.g. laundry, dish washing, bathing, cleaning). This water will have some pathogens in it

Both types of wastewater have to be disposed of safely. In most cases grey water can be reused for irrigation with little or no treatment. Reusing black water is more difficult because it contains a high amount of pathogens. Storing and settling black water for 24 hours or more can reduce many of the pathogens; however it is still recommended that black water only be used to irrigate crops that will not be eaten raw (WHO, 2006).

Wastewater must be fairly clean before infiltrating it into the ground. The suspended solids, grease and scum in dirty wastewater will clog the soil and reduce the infiltration rate. Black water is normally clarified by passing it through a septic tank. A grease trap is used to clarify grey water before it is infiltrated into the ground. Both serve the same function: they let gravity settle suspended solids to the bottom of the tank and let grease and scum float to the surface.

Even grey water used for irrigation should pass through a grease trap to remove food particles, soap, and grease that may damage the crop.

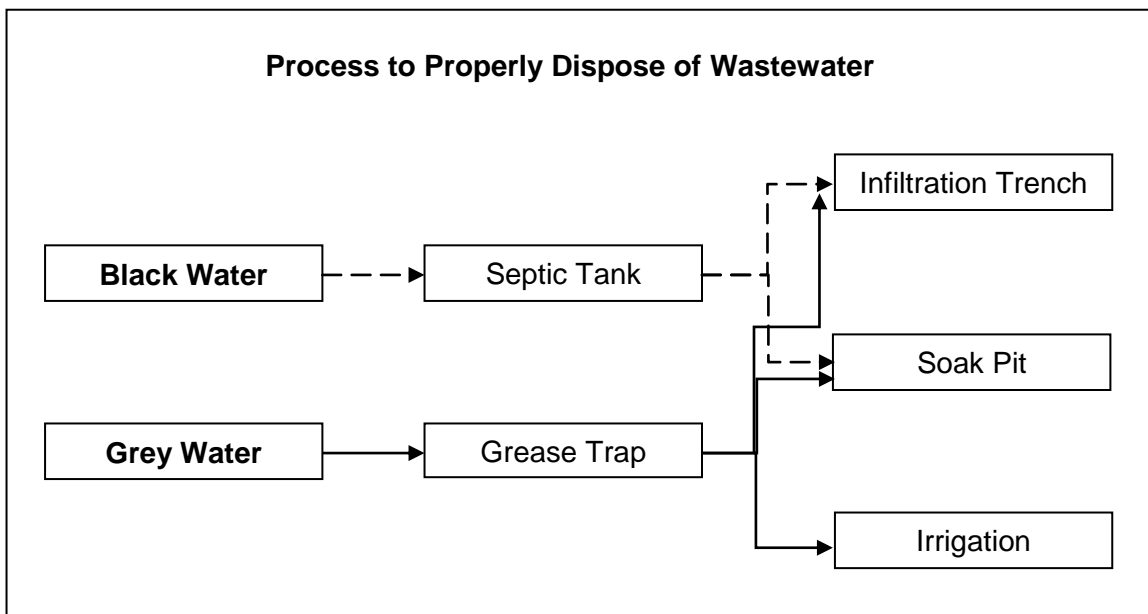

If wastewater is clean (for example, water spilled at a hand pump or tap stand) it can be channelled directly to a garden or drainage channel without being treated. This can be done by building a concrete apron around the water point to direct the spilled water and prevent it from pooling at the site.

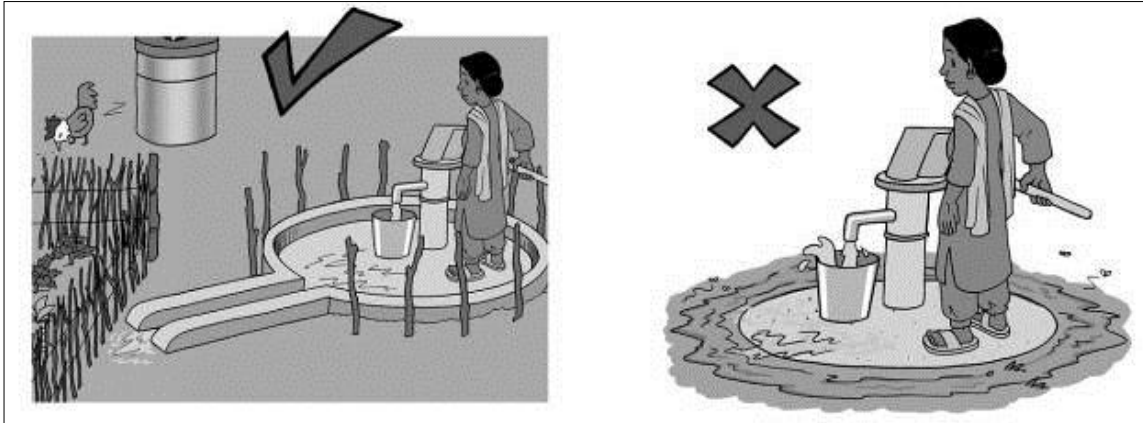

Soak pits, septic tanks, grease traps and drainage channels should be built in a way that prevents rain water from flowing into the systems. Rain water can quickly flood these systems and could cause permanent damage.

7.1 Grease Traps

A grease trap acts like a miniature septic tank. Dirty water flows into the trap where oils, fats and soap scum can float to the surface and while gravity settles heavier suspended solids to the bottom. Relatively clean water then flows out.

It is important to install a grease trap before infiltrating grey water into the ground or discharging it to drainage channels. This lowers the risk of clogging the soak pit or infiltration trench and reduces the potential amount of pollution entering the drainage systems.

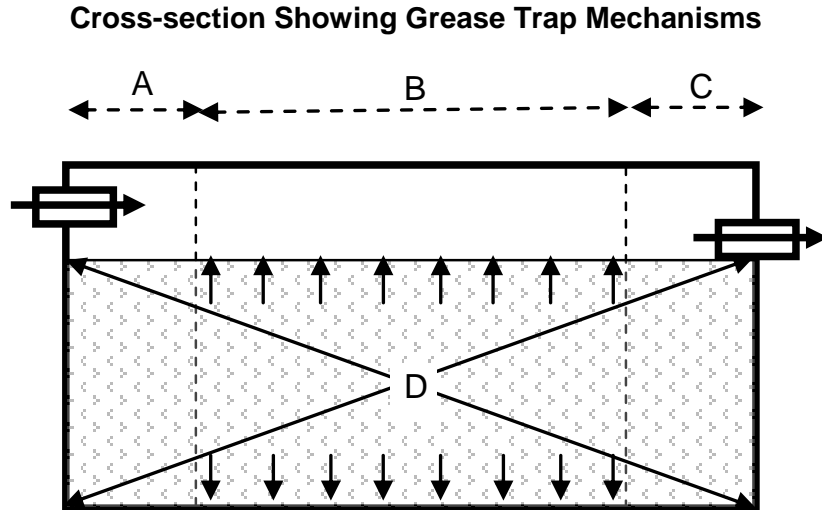
**Legend:**

A = Inlet – The inflow water slows down and is distributed across the trap.

B = Trapping Area – Lighter grease and scum float to the surface and the suspended solids settle to the bottom.

C = Outlet – Water with reduced sediment, grease and scum flows out.

D = Effective Volume – Quantity of wastewater held in the trap under normal operating conditions.

7.1.1 Grease Trap Designs

Three simple types of grease trap are described below. The design will depend on the local context and available resources and skills:

1. Masonry box with an elbow at the inlet and a “T” at the outlet (simplest solution).
2. Masonry box with baffles to create three separated compartments (good solids removal).

Construction using an oil drum (small trap – effective volume approx 80 litres).

<p>Simple Masonry Box using Elbows and Tees</p>	<p>Legend:</p> <ol style="list-style-type: none"> 1. Removable cover(s) 2. Watertight casing 3. Inlet elbow, 90° 4. Outlet tee 5. Floating grease and scum 6. Settled solids
<p>Masonry Grease Trap With 2 Baffles</p>	<p>Legend:</p> <ol style="list-style-type: none"> 1. Removable cover(s) 2. Watertight casing 3. Inlet pipe 4. Outlet pipe (an elbow or tee can be used) 5. Floating grease and scum 6. Settled solids
<p>Grease Trap Made From 200 Litre Oil Drum</p>	<p>Legend:</p> <ol style="list-style-type: none"> 1. Removable cover(s) 2. Drum cut in half 3. Inlet pipe 4. Outlet pipe (an elbow or tee can be used). 5. Floating grease and scum 6. Settled solids 7. Top and bottom cut from other half of drum. Cut three 7–10 cm holes in each half, and weld in place.

7.1.2 Determining the Size of a Grease Trap

You will need to design the grease trap to ensure that wastewater is allowed to sit in the trap for at least 2 hours (i.e. its retention time must be two hours). This means its effective volume must be equivalent to double the maximum amount of wastewater flowing into the trap in one hour. The effective volume is the amount of wastewater held in the trap under normal operating conditions.

For a household where all water is carried by hand, it is reasonable to assume that the maximum flow into the trap in one hour would be approximately 40 litres, therefore the trap requires an effective volume of 80 litres.

7.1.3 Construction

- Ensure that the grease trap is constructed and installed so that gravity can pull the wastewater through the system
- Design the grease trap according to the required retention time and effective volume (see above)
- Construct the grease trap using locally available materials (e.g. cast concrete, plastered brick or concrete blocks, or re-used oil drums or similar)
- Position and test the inlet and outlet pipes to ensure that there is sufficient “dead space” at the water surface to trap the floating material. Dead space is the empty space at the top of the container where fat and scum can accumulate.
- Ensure that covers fit and seal well on the trap to prevent rodents and insects from entering and breeding inside the trap. If concrete is used, a single cover may be very heavy. In this case, covers should be divided into sections to make sure each one is of a manageable weight.
- Ensure that rain water and surface runoff water cannot enter the trap, and arrange drainage channels to ensure water flows away from the trap.

7.1.4 Maintenance

It is absolutely essential to maintain and clean grease traps. The trap should be inspected weekly and cleaned as needed. Regular cleaning will reduce the potential for overflow and minimize odours. Cleaning grease traps can be an unpleasant job. Encourage people to use gloves and to wash their hands afterwards. Material removed from the trap should be buried in a pit.

The users must be able to recognize when a grease trap requires cleaning. Possible indicators are:

- Soapy water is seen leaving the trap or entering the infiltration system
- Water is seen overflowing from the infiltration system
- Water is seen overflowing from the grease trap

7.2 Soak Pits

A soak pit is a dug pit that allows wastewater to be safely infiltrated into the ground. Pits must be lined or filled with rocks to prevent erosion and to prevent the walls from collapsing. The size of the soak pit is based on the amount of wastewater entering the pit and whether the water is clean or dirty. Infiltration only happens through the side walls of the soak pit. Almost no infiltration occurs through the base of the pit because it quickly clogs with solids. It is important to design the size of the soak pit to handle peak flows of wastewater, especially if the infiltration capacity of the surrounding soil is low.

The simplest and quickest way to build a soak pit is to dig a pit and fill it with rocks. However, the rocks reduce the volume of wastewater that the pit can hold and finding enough rock may be difficult in some places.

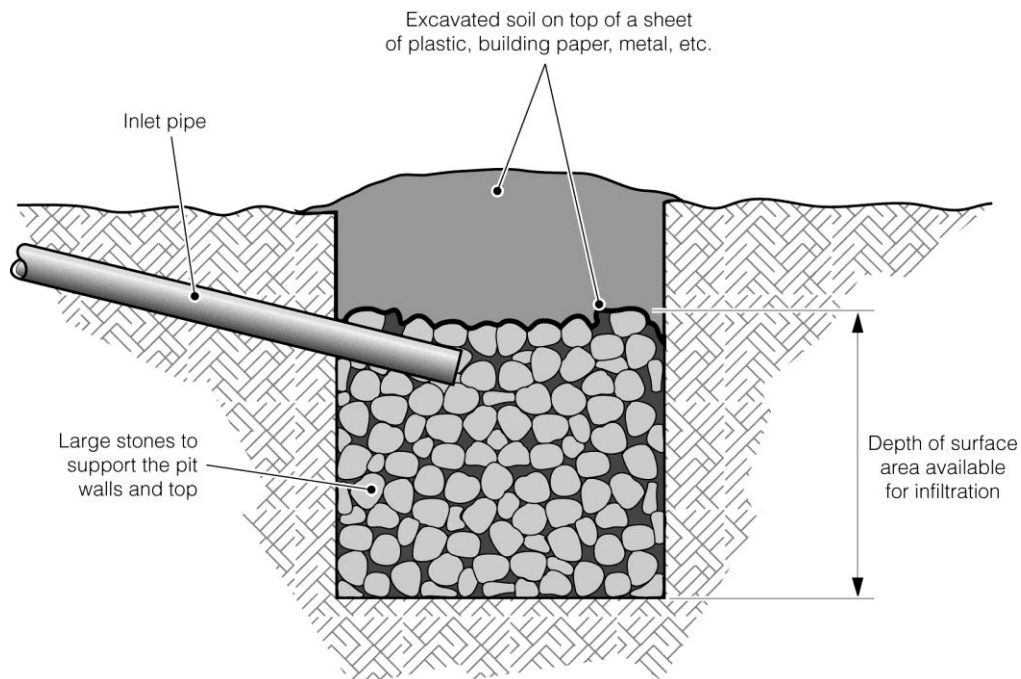

Soak pit filled with rocks and covered sheet and soil (Credit: Chatterton, WEDC)

Lining the soak pit walls with bricks or blocks overcomes both of these issues but increases the construction time and difficulty. Bricks should be installed using one of the methods in the diagrams below. Honeycomb brickwork, or brickwork where the vertical joints between the bricks is not be mortared, allow the wastewater to pass through the bricks and into the soil. Interlocking blocks that require no mortar and allow wastewater to pass through the vertical and horizontal joints between the blocks may also be available in some areas.

More information about soak pit sizing can be found in Appendix 3.

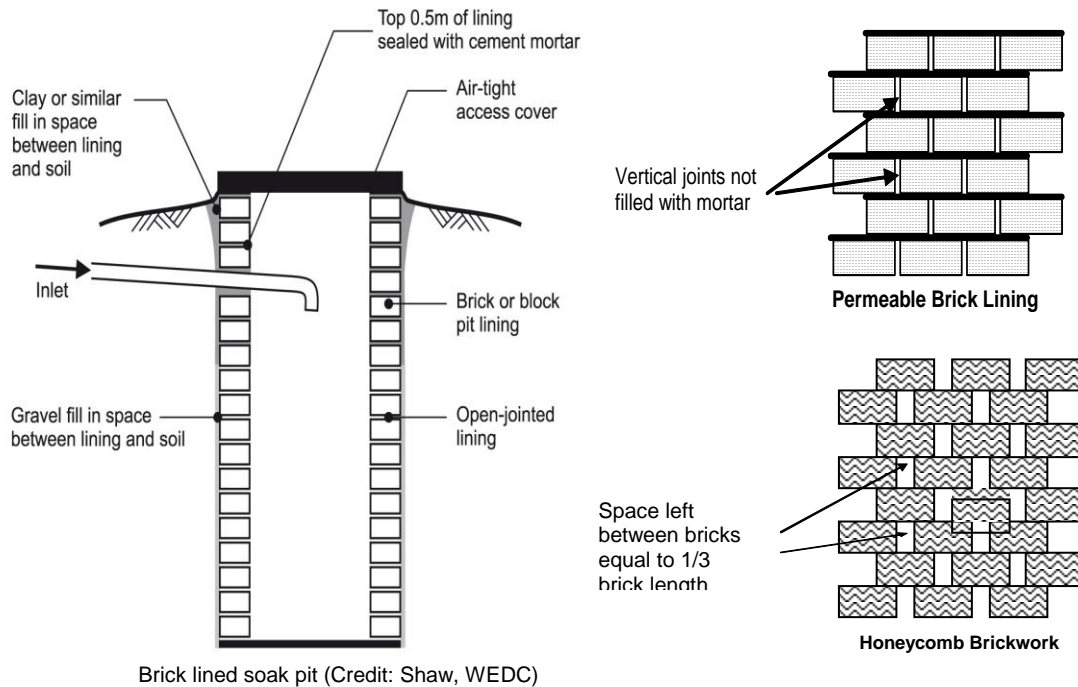

Trenches can be used in situations where a soak pit is unable to infiltrate the total amount of wastewater. This can be either because of low soil infiltration capacity, large amounts of wastewater or a combination of the two.

Infiltration trenches are long shallow pits. They require more planning, space and materials than a soak pit but create a much greater surface area for infiltration into the soil. Infiltration trenches are often used in conjunction with septic tanks.

The distance between trenches should be at least 1.5 metres to allow effective infiltration. Like soak pits, trenches can also become clogged with solids even when it is combined with a grease trap or septic tank. However, the infiltration capacity can be restored if an infiltration trench is not used for a few months. For this reason, trenches are sometimes built to be approximately 1/3 bigger than the effective volume calls for in order to allow parts of the trench to be used while others dry out.

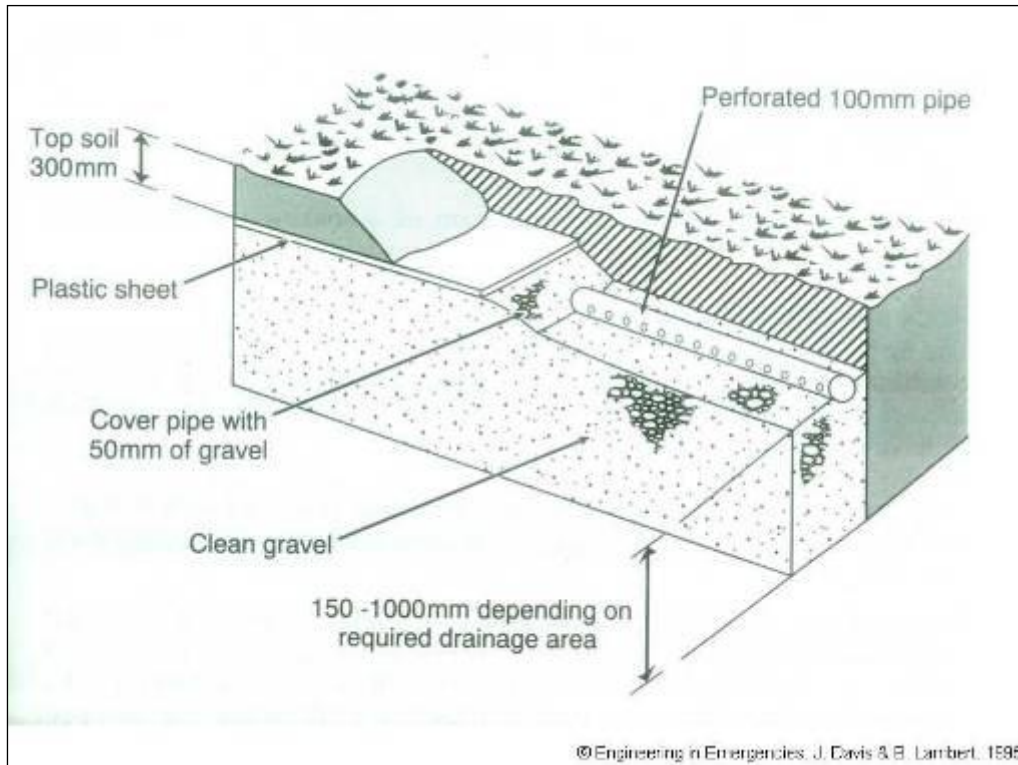

Infiltration trench

7.3 Surface Water Drainage

Rainwater should not be put through soak pits or infiltration trenches because large amounts of water at one time can cause the systems to overflow. The exception would be where special infiltration wells are constructed that are designed replenish groundwater sources. Where localized flooding occurs, it may be possible to ease the flow of the rainwater along its natural drainage routes by constructing drainage channels. These can be lined with concrete, brick or stone to prevent erosion. A smooth finish and straight channels will allow the rain water to flow out of the area more quickly.

In many places, drainage channels become garbage dumps for household waste. Channels must be kept clean of waste to prevent them from blocking water flow and causing additional flooding.

In many places, surface drainage channels are also used for the disposal of domestic wastewater. If constructing household soak pits is not possible due to high water tables or space limitations, then installing grease traps should be considered to at least clarify the wastewater before it flows into a drainage channel. If black water is being discharged to drainage channels, and circumstances permit, then a low cost settled sewage system should be considered.

8 Improved Hygiene

Hygiene can be defined in many ways depending on the particular culture. The common understanding of hygiene refers to the behaviour associated with protecting health and healthy living.

Most people practice personal hygiene to a certain degree. Good personal hygiene practices include:

- Hand washing
- Bathing regularly
- Washing children's hands and face
- Washing hair
- Cleaning teeth



Seven Key Hygiene Messages to Change Behaviour and Improve Health in the Household:

1. All feces should be disposed of safely. Using a toilet or latrine is the best way.
2. All family members, including children, need to wash their hands thoroughly with soap and water or ash and water after contact with feces, before touching food, and before feeding children.
3. Washing the face with soap and water every day helps to prevent eye infections.
4. Only use water that is from a safe source or is treated and stored safely.
5. Raw food should be washed or cooked. Cooked food should be eaten without delay or thoroughly reheated.
6. Food, utensils and food preparation surfaces should be kept clean. Food should be stored in covered containers.
7. Household garbage should be properly disposed of.

(Adapted from UNICEF, 2002)

Of these seven activities, **hand washing with soap is the single most important hygiene measure** in preventing the spread of pathogens. The evidence suggests that soap--any soap--and water adequately removes dirt and pathogens from hands. Antibacterial soaps or other hand-sanitizing technologies have no additional advantage. In studies around the world, the main reason given why rates of hand washing with soap are so low is that *it is simply not a habit* (World Bank, 2005).

Directions for Proper Hand Washing (3 x 3 Method)

The three times when hands should be washed are:

1. Before cooking or preparing food.
2. Before eating or before feeding children.
3. After defecating and after changing or cleaning babies



The three steps to washing hands are:

1. Wash both hands with water and soap or ash.
2. Rub the front and back of your hands and in between your fingers at least three times.
3. Dry hands with a clean towel or air dry.

Domestic hygiene practices around the house include washing clothes and bedding, sweeping the floors, storing food properly, preparing and handling food properly and disposing of household garbage properly

Many hygiene practices require water. Where water is scarce or when too much time is consumed in hauling or treating water, some hygiene practices will not be done. The easier and less time consuming these activities are made, the more likely it is that the hygiene practices will be adopted.

Cultural norms must also be considered. People are used to doing things in a certain way and may be reluctant to try methods that are too different from what they are used to. Local knowledge is essential in developing an appropriate hygiene project. Some things to consider include:

- Religious traditions or taboos
- Women's and girls' privacy requirements (for bathing and latrines)
- Current laundry methods

Many hygiene projects are effective in the short term, but people's behaviour often reverts to their old habits soon after the project ends. For improved hygiene to become a sustained behaviour change over the long term, any project must have an effective strategy for hygiene promotion.



When to wash your hands

8.1 Hand Washing Facilities

Hand washing facilities should be available close to every latrine. The facilities can be as simple as a container of water and a bar of soap or container of ash, or as complex as a hand washing basin with hot and cold running water and a drainage system. The main points are that the facilities are available, conveniently located and easy to use.

Water for hand washing can be stored in almost any type of container (e.g. buckets, jerrycans, bottles, gourds). Containers with taps or some other method of controlling the flow of water are preferred.

An automatic hand washing device called the “tippy tap” (seen in the hand washing illustration above) was developed at the Blair Institute in Zimbabwe. The original design used a common gourd found in Zimbabwe. The design evolved to use discarded plastic containers for the construction. A useful modification is the addition of a foot pedal so that no part of the tippy tap needs to be touched with the hands. Other designs and modifications to the original have been made over the years but whatever the design, these types of devices are universally known as tippy taps.

Another simple technique for hand washing is to make a small hole in a ladle or dipper. Water is scooped into the ladle, hung over the side of the bucket and a small stream flows out of the hole.

8.1.1 Hand Washing Wastewater Disposal

The quantity of wastewater produced from washing hands at a family latrine will be quite small. Nevertheless, this water should be properly disposed of to prevent pools of stagnant water from forming. There is also a risk that fecal matter and pathogens may be present in the wastewater. In communal latrines, the amount of wastewater will be much greater and its disposal must be carefully thought out.

If the latrine has a wet pit or a septic system-- i.e. a pour flush toilet--then the wastewater from hand washing can be discharged into the pit or into the septic tank.

If the toilet has a dry pit then the wastewater should be discharged into a separate infiltration system. If the ground is porous and there is no risk of contaminating ground water supplies then the wastewater could be discharged into the latrine pit. The small amount of water would infiltrate fairly quickly and would not interfere with the decomposition conditions in the pit.

In most cases a grease trap and soak pit would be the most appropriate solution. The grease trap and soak pit can be quite small because hand washing doesn't produce a large amount of wastewater. Another option is to direct



Wastewater going into soak pit

the wastewater to plants or a tree. If the plants or tree are useful producers then that could encourage people to wash their hands in order for the wastewater to “feed” the tree.

8.1.2 Soap and Ash

Soap

Much of the dirt on our hands is bound together with oils and fats which water alone is not very effective in removing. However, soap mixed with water is very effective at dissolving oils and releasing the attached dirt which is then rinsed off.

The friction created when rubbing the hands together to wash them also plays a major role in removing dirt and pathogens. Soap tends to be naturally alkaline which can also have a mild antibacterial effect.

Wood Ash

Where no soap is available or where people find it too expensive, an alternative is to use the ash from a wood fire. When mixed with water, wood ash has some of the same properties of soap--it is alkaline and dissolves oils. As well, it is somewhat abrasive and helps rub dirt off the hands. An additional benefit is that when the ash is applied to the hands they appear visibly dirty and this can encourage a more thorough cleaning and rinsing.

Animal Dung Ash

Dried cow dung is used widely in South and Central Asia as a fuel for cooking and heating. In India, the ash produced has traditionally been used to prolong the storage life of wheat grains, and has also been used as a cleaning agent for domestic utensils and cooking pots. Similarly to wood ash, the ash from well-burnt cow dung can be used as an alternative to soap for hand washing.

9 Solid Waste Management

Solid waste is waste from human activities that is thrown away as useless or unwanted. It is also called other names like rubbish, trash, refuse or garbage. Human and animal excreta are not considered to be solid waste and are managed differently as discussed in the previous sections of this manual.

Solid waste is uncontrolled in many parts of the world. A typical solid waste management system in a developing country has a variety of problems, including low collection coverage and irregular collection services, open dumping, burning, air and water pollution control, the breeding of disease vectors and unsafe handling through informal waste picking activities (Ogawa, 1996).

Risks Associated with Poor Waste Management



- Breeding site for vectors, including flies, rats and mosquitoes
- Air, water and general pollution resulting in respiratory problems, poor water quality, decline in living conditions
- Fire
- Contact with hazardous waste
- Blocked drains causing increased flooding

Waste management is a process with different stages where intervention activities can be effective. Generally, the earlier a waste management activity is practiced in the process, the better.

Waste Management Stages and Activities

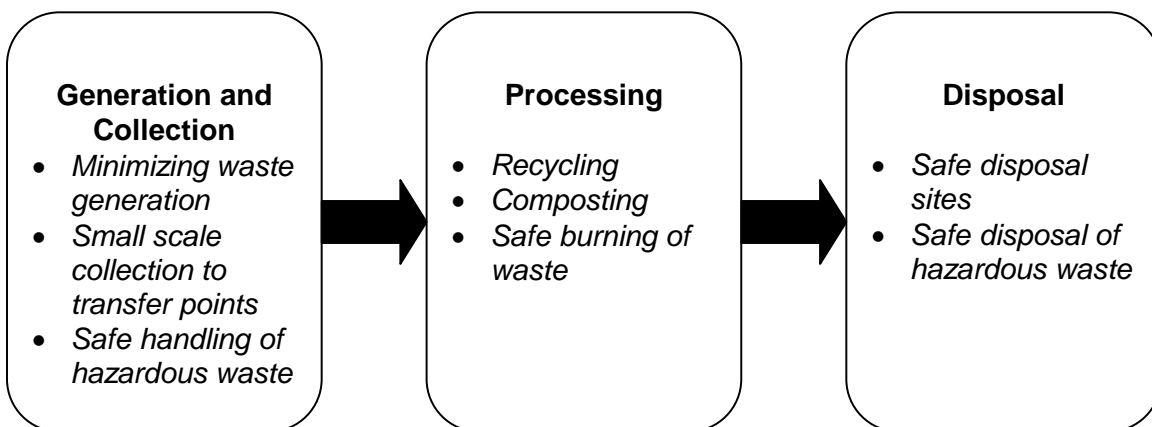

9.1 Generation and Collection

The poor in developing countries produce significantly less waste (about 0.4 to 0.9 kg per person per day) than people living in industrialized countries (between 1.1 and 5.07 kg per person per day). The poor living in rural communities also tend to produce less waste than those living in urban areas since they have less income and less access to consumer products. However, urbanization and rising incomes will eventually lead to the use of more resources and therefore more waste (Hoornweg and Thomas, 1999).

Waste composition—or what waste is made up of—is also influenced by external factors such as geographical location, the population's standard of living, energy source and weather. Generally, the waste produced by low and middle income countries contains a high percentage of compostable organic matter, ranging from 40 to 85% of the total. Studies show that as populations become wealthier and more urbanized, their waste composition changes to have a higher percentage of consumer packaging materials such as paper, plastic, glass and metal (Hoornweg and Thomas, 1999).

Minimizing the amount of waste a community generates reduces the need for collection, increases the lifetime of a landfill and reduces the cost for collection services. Collection can account for almost 50% of the total annual cost of urban solid waste management (Tchobanoglous *et al.*, 1993).

Most urban centres have some kind of waste collection and disposal service. These services often only cover the wealthy, built up sections of the city. Peri-urban and unplanned informal housing areas may have no or limited service, and in these settings waste is usually collected from centralized points located at the perimeter of the area. In such cases, large scale methods of transport (e.g. trucks, compactors) won't usually work because of the width, slope, congestion and surface of the roads. A possible solution in densely populated communities is to use hand carts, semi-motorized carts, front-loaded tricycles or donkey carts to transport waste to a transfer point.



Motorcycle and solid waste cart (Credit: Shaw, WEDC)

Collecting payment for waste collection services can sometimes be difficult. Various methods have been used:

1. Voucher arrangement for individual pickups
2. Monthly fee
3. Including fees in an already billed service such as electricity or water

It is very important that people are educated about fee collection and agree on the method before they receive the services. In poorer areas, scaled prices or limited collection options may need to be investigated.

9.2 Processing

9.2.1 Recycling

Separating recyclable paper, metal, plastic and glass within the household is already a common practice in many developing countries. Recycling rates are very high in developing countries since it is a way for many people to informally earn a living. Materials that are most often recycled include paper, glass and metal due to their high market prices. When planning a project that promotes recycling, it is important to find out if there is already a local market for recyclable goods or if one needs to be created.

In developing countries, recycling is usually part of the informal sector (activities that are not monitored by the government). Often it is waste pickers who sort out recyclable materials from mixed waste at gutters, street bins and piles, markets, transfer points, collection trucks and dumps (legal and illegal). They generally sell the recyclables to a middleman who in turn sells it to a company that will use or export the material.



Informal waste picking activities are seldom recognized, supported or promoted by the municipal authorities. Most waste pickers are poor, and their work is among the most risk-ridden of occupations in urban areas; they live in very poor conditions, and suffer stigmatization and exploitation because handling waste materials is often looked upon poorly by society at large (Furedy, 1999).

9.2.2 Compost

Composting is a natural process that decomposes organic material (material that once came from a living thing) into a valuable soil additive that can be used for agriculture. Composting is especially appropriate in many developing countries and has the following benefits:

- Increases overall waste diversion from final disposal, especially since as much as 85% of the waste stream in low- and middle- income countries is compostable
- Enhances recycling by removing organic matter from the waste stream
- Reduces landfill leachate and methane gas (a greenhouse gas that is 21 times more potent than carbon dioxide).
- Enhances the effectiveness of fertilizer application
- Reduces waste collection and transportation requirements
- Flexible for implementation at different levels, from household efforts to large-scale centralized facilities
- Can be started with very little capital and operating costs
- Accommodates seasonal waste fluctuations, such as leaves and crop residue

(Adapted from Hoornweg et al., 1999b)

Composting can take anywhere from two weeks in hot and humid countries with well-tended piles to a few years in colder countries with untended piles. The process needs water, oxygen and organic materials such as household food waste and agricultural waste (e.g. husks, leaves).

Household composting can be a simple way to manage kitchen and garden waste. It could be promoted when a significant number of homes have individual or collective yards or gardens in which to use the end product and where there is sufficient space for the compost units.

There are many different designs and options for composting. Composting units can be made out of locally available materials such as wood, bamboo, clay bricks and wire mesh. The design and operation of the composters should not attract rodents, insects or other scavenging animals. Keeping large quantities of meat, fish and fatty food out of the composter is the best way to keep pests away from the unit. Public health officials may discourage household composting because of perceived health risks. However, projects can overcome this concern through public awareness programs and by educating people on proper composting practices (e.g., how to minimize the presence of rodents and flies) (Hoornweg *et al.*, 1999b).

Vermicomposting may also work in developing countries, especially at the household and community level in urban centers. This process uses the natural digestion of redworms and earthworms to break down organic material. From the moment it hatches, a worm can consume daily its body weight in organic matter such as vegetables, fruit, leaves, grass, meat, fish, sludge, cardboard and paper. The waste is continuously turned and mixed as the worms burrow through the medium. Worms can be housed in any ventilated container with a lid provided that the bottom has drainage holes or a layer of gravel to allow liquid created in the process to drain (Hoornweg *et al.*, 1999b).

Further details about composting are provided in CAWST's Composting Technical Brief.

Apartment Composting in India

Patna, India has a population of about one million with little door-to-door waste collection nor any composting facilities or sanitary landfills. On average a three person household generates 2.1 kg of food waste each week. Backyard composting is used by some households, but this is not an option for those living in apartments. A composting method was developed for apartment dwellers to use their balconies and window sills. Excess water is drained from the organic waste and placed in clay pots. Soil supplemented with floor sweepings and dried moss from roof tops is added to equal amounts of waste. The compost matures in 3 to 4 months and is used directly for planting without further additions of fertilizer or chemicals. Flowers, ornamental plants, spinach, and tomatoes are successfully grown in the compost.

(Mazumdar, 1992)

9.2.3 Burning

Burning waste is commonly practiced in many parts of the world. It is usually done to reduce the volume of waste to be disposed of. Burning is not the best option for waste processing unless it is being properly incinerated (burned at extremely high temperatures in a controlled environment). However, incinerators are rarely found in developing countries because they are technically complex and very costly.

Open burning releases harmful chemicals into the air. It creates thick smoke that contains carbon monoxide, soot and nitrogen oxide, all of which are hazardous to human health and air quality. Burning plastics like polyvinyl chlorides (PVCs) also produce chemicals that can cause cancer (Bickel, 1996). However, there are materials such as wood, paper and construction debris that are less harmful when burned and are commonly used as fuel.

It may be necessary to burn garbage if landfill space is very limited. In this case, it is best to burn garbage as far as possible from people, keep it contained in a pit to prevent uncontrolled spreading, and burn it as hot as possible. The ashes may be contaminated and should be disposed of in a pit or landfill.

9.3 Disposal

All communities will produce some waste even with the best minimization and treatment practices. The most common way to deal with this waste is to bury it. In industrialized countries, waste is disposed of in sanitary landfills where they are engineered to meet environmental regulations. This type of landfill is designed to protect soil, ground and surface water; reduce odours and pests; capture leachate; and reduce harmful gas emissions. Sanitary landfills can be found in some developing countries, often in large cities. However, open dumping is more common due to a lack of the resources needed to properly construct and operate a sanitary landfill.

In small rural communities that produce relatively small quantities of waste, individual households can manage the disposal of their waste on-site. In larger rural communities, waste disposal may be best managed as a community service, with one or several conveniently located, large waste disposal sites shared by everyone. In this case, individuals can either transport their own waste to the site or organize a collection service similar to those found in urban areas.



The following are recommendations for locating and maintaining a disposal site that works in a rural, urban, individual or communal area:

- Locate the site at least 500 metres away from drinking water sources
- Do not site in an area with a high water table
- Do not site in an area susceptible to flooding
- Site above clay-like soil if possible (the finer the grain the better)
- Cover waste with soil on a regular basis (e.g. daily or weekly) to reduce odours, pests and potential for the garbage to be blown away
- Construct a fence to keep animals and children out of the dump site

9.4 Hazardous Waste

Proper and safe disposal of hazardous waste is a large problem in developing countries. Hazardous waste includes:

- Toxic waste
- Medical waste
- Pharmaceuticals
- Chemicals
- Batteries

This waste needs specialized treatment beyond just putting it in a landfill. However, much of the risk from hazardous waste occurs in the stages before disposal. For example, needles from syringes that are not separated from the regular waste stream can pose a large threat to waste collectors and waste pickers.

In many cases, the technology needed to dispose of hazardous waste is not affordable or feasible (i.e. incinerators). However, there are actions that can be taken to minimize exposure to hazardous waste such as:

- Using less hazardous materials as substitutes
- Separating hazardous waste from the general waste stream
- Using better storage before and during collection



Do not reuse containers that held hazardous material, **do not burn** hazardous waste, and **do not dispose** of hazardous waste in latrines, drainage channels, water sources or on the ground.

9.5 Solid Waste Attitudes

Waste management is often a very low priority for people even though it is an obvious and very visible issue in many rural, peri-urban and urban communities. Generally, individuals and communities prioritize safe drinking water projects above sanitation, and especially above solid waste management.

Other attitudes that may have to be overcome are stigmas that are attached to the handling of waste. Some cultures may not find it acceptable to handle waste or find it inconvenient to separate waste. They may also look poorly upon those whose job it is to collect or transport the waste, in particular waste pickers who are not officially recognized.

It may be difficult to change people's attitudes and behaviours. Behaviour change is necessary to get people to spend the effort, time and money needed to separate waste into recyclables, compostable material and general waste and to dispose of it properly. Community desire and awareness coupled with culturally sensitive and appropriate solutions are necessary for a successful solid waste project.

9.6 Further Information

Bickel, S. (1996). Environmental Guidelines for Small Scale Activities in Africa. Chapter 15 – Solid waste: generation, handling, treatment and disposal. Bureau for Africa's Office of Sustainable Development. Available at: www.encapafrica.org/egssaa.htm

Hoornweg, D., Thomas, L. and L. Otten (1999b). Composting and its Applicability in Developing Countries. Urban Waste Management, Working Paper Series, 8. The World Bank, Washington, DC, USA. Available at: www.worldbank.org/urban/solid_wm/erm/CWG%20folder/uwp8.pdf

10 Vector Control

Vectors include mosquitoes, flies and rodents which are common nuisances in many developing countries. They thrive in areas where there is poor sanitation, for example, standing water provides breeding sites for mosquitoes, garbage attracts pests and feces attracts flies. These vectors are carriers of many serious diseases.

- **Mosquitoes** – Transmit a number of viral diseases such as **Dengue Fever**, **Japanese Encephalitis** and **West Nile Fever**. **Malaria** is a protozoa that is passed on by mosquitoes. About 1.3 million people die each year of malaria, 90% are children under the age of five. There are 396 million cases of malaria every year, most of them in sub-Saharan Africa (WHO, 2004).
- **Flies** – Carry pathogens on their bodies to uncovered food and drink, and to the faces, mouths and eyes of people. **Trachoma** is an eye infection that spreads from person to person. It is frequently passed from child to child and from child to mother, especially where there are shortages of water, numerous flies and crowded living conditions.

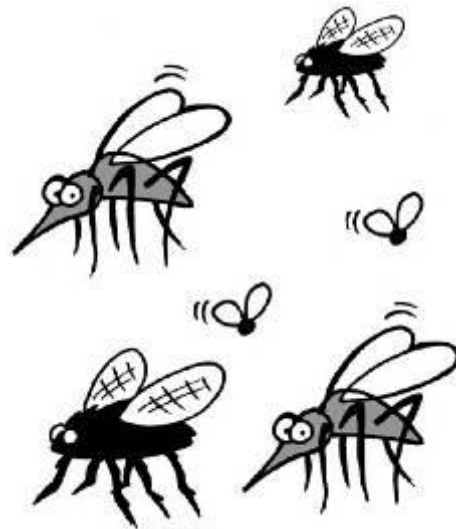

- **Rats, mice and other rodents** – Carry pathogens on their bodies. They act as vectors for **Hantavirus**, **Typhus**, **Leptospirosis** and the **plague**.

Fortunately there are various measures that can be taken to control these vectors, many of which are appropriate for households and communities with limited resources.

10.1 Mosquito Control

Different strategies can be used to reduce and prevent contact with biting mosquitoes. Screens and nets, chemical controls (i.e. spraying bug repellent), environmental measures and human behaviour change are effective strategies to limit contact with pathogen carrying mosquitoes.

Mosquitoes are present worldwide with the exception of Antarctica. There are 41 different genera (types) which are sub-divided into 3,300 species. There are three genera of mosquitoes that are important in the transmission of disease: Anopheles, Culex and Aedes. They transmit various diseases and are quite different in their breeding and biting behaviours. The following table gives the most common characteristics for the different genera of mosquitoes. However, there are many variations and exceptions depending on the species.

Mosquito Characteristics

Mosquito	Diseases	Breeding	Biting	Flight Range*
Aedes	Dengue, Yellow Fever, Arboviruses	Breeds in clean stagnant water, preferably shaded. Often breeds in small temporary pools caused by flooding. Commonly referred to as a “container breeder.” Eggs can survive being dried out.	Variable but most species are day biters with peak biting at dawn and dusk into early evening. Easily disturbed but persistent biters, so will deliver multiple bites on several hosts. Bites are often painful.	Usually less than 150 metres, but can be up to 750 metres in rural settings, and 570 metres in urban areas.
Anopheles	Malaria	Breeds in relatively clean, shallow water in any size of usually permanent water body, preferably shaded. Some species will breed in brackish, saline water.	Bites at night, mainly just after dark and before first light. Less easily disturbed, so usually only bite a few times.	Usually up to 2 kilometres, but some may fly many kilometres.
Culex	West Nile Virus, Lymphatic Filariasis, Japanese Encephalitis	Breeds almost anywhere, but favours dirty water with high organic matter (e.g. septic tanks, latrines)	Bites at night and persistent biter.	Usually less than 1 kilometre, but may fly several kilometres.

* The flight range of mosquitoes was long thought to be quite limited. However, recent research suggests flight range is significantly longer.

** Recent research has found that *Aedes aegypti* mosquitoes have adapted to breeding in septic tanks and other large and dirty water reservoirs.

The average lifespan of a male mosquito is approximately 2 to 3 weeks. The lifespan of a female mosquito is usually longer and can be up to 3 months. Actual lifespan depends on the mosquito's species and the temperature of its environment. Female mosquitoes will go through 3 egg laying cycles and will produce 300 to 1,000 eggs in a lifetime.

The following map shows the specific species of Anopheles mosquito that are mainly responsible for malaria transmission in different countries. There are approximately 40 species of Anopheles mosquitoes that transmit malaria. Each species behaves slightly differently and therefore requires its own strategy if it is to be controlled. It is important to determine which types of mosquitoes are responsible for disease transmission in the area where a control program is planned.

Global Distribution of Anopheles Mosquitoes

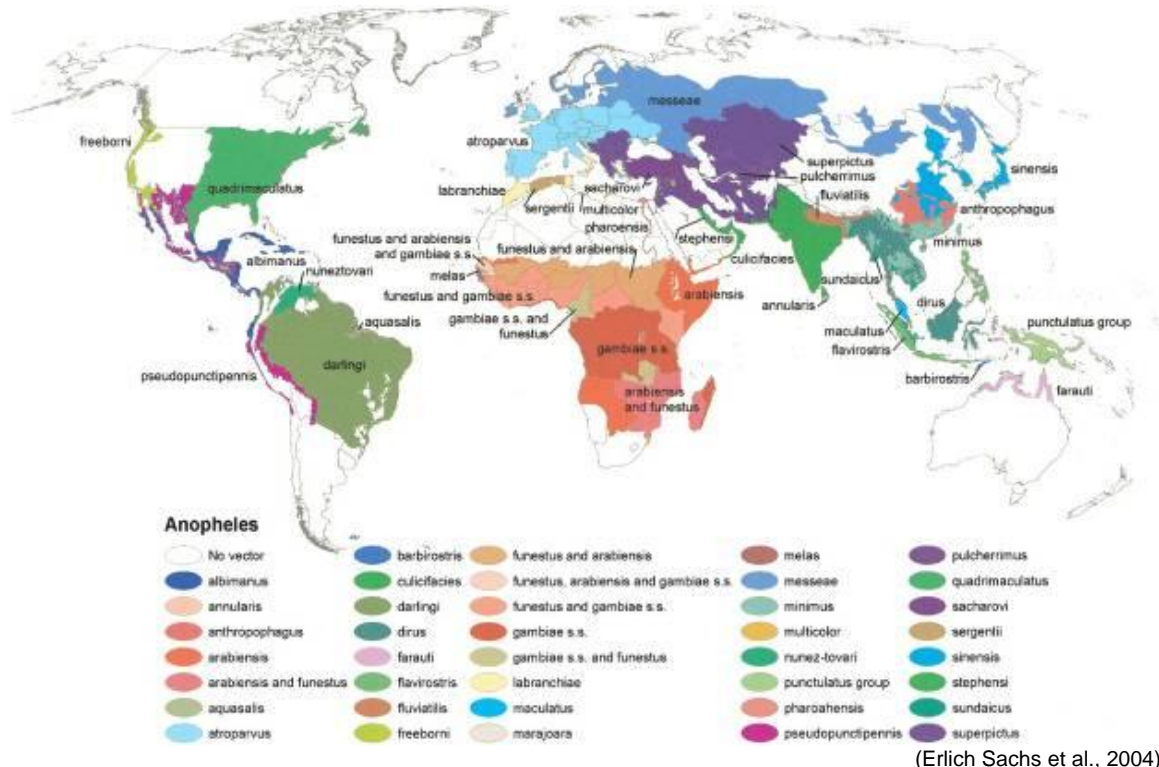

10.1.1 Mosquito Disease Transmission

Mosquitoes feed for the most part on plant nectar and sap. It is only the female mosquito that bites humans and other mammals and birds. The female needs a blood meal in order to take in protein which is essential for egg production. It is during the blood feeding that the pathogens are passed from the mosquito to the human.

Transmission of Malaria

- A mosquito bites an infected person.
- Blood containing malaria protozoa is ingested.
- The protozoa develop in the mosquito before becoming infectious (10 to 21 days depending on the species and local temperature).
- The mosquito bites another person and injects malaria protozoa into the new person's bloodstream.
- The protozoa develop, cause malarial disease and become infectious again (7 to 30 days depending on type of malaria).

Transmission of Japanese Encephalitis

- A mosquito bites a bird carrying Japanese encephalitis virus (bird is the reservoir and not affected).
- The mosquito then bites a pig and injects the virus into the pig.
- The encephalitis virus reproduces and accumulates in the pig (the pig is not affected).
- A mosquito bites the pig.
- The mosquito bites a person and injects the virus into that person's blood stream.
- The virus infects the person who then becomes sick.

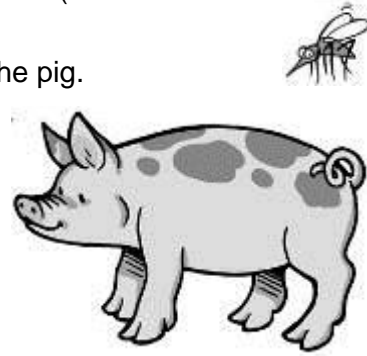

Mosquito bitina a pia

Transmission of Dengue Fever

- A mosquito bites an infected person.
- Blood containing the dengue virus is ingested by the mosquito.
- The virus replicates in the mosquito.
- The mosquito is infectious for life and can transmit the virus to its offspring.
- The mosquito bites an uninfected person and injects the virus into their blood stream.
- The virus infects the person who becomes sick within 2 to 7 days.

10.1.2 Control Strategies

There are four main strategies for preventing mosquito borne diseases:

1. Screens and nets
 - Preventing mosquitoes from entering buildings by screening doors and windows.
 - Preventing mosquito bites by sleeping under bed nets.
2. Chemical & biological methods
 - Killing mosquitoes either as adults or as larvae by using insecticides and larvicides.
 - Adding to the effectiveness of bed nets by coating the nets with insecticide.
 - Burning mosquito coils with insecticidal and repellent properties.
3. Environmental measures
 - Reducing the population and presence of mosquitoes by removing breeding and resting sites.
 - Reducing transmission by removing intermediate and amplifying hosts (i.e. 1992 Singapore stopped pig breeding to tackle Japanese encephalitis).
4. Behaviour change
 - Sleeping under a bed net.
 - Wearing full-cover clothing or staying indoors during biting periods.
 - Using mosquito repellent.

Screens and Nets

Screens and nets are often the simplest methods to reduce or prevent mosquito bites inside the home and while sleeping, although it can be relatively expensive for the poor. Steel or plastic screen with a mesh size small enough to prevent mosquitoes from being able to enter is available virtually everywhere that there are mosquitoes. If sand flies are a problem and Leishmaniasis (Kala Azar) is common then smaller mesh sizes (<1 millimetres) should be used for screens and bed nets. Installing screens on doors and windows will reduce the number of mosquitoes, flies and other bugs that enter the home. Some places will require extra work and attention, especially where traditional homes have gaps between the walls and the roof.

Bed nets can be very effective at preventing mosquito bites. However, if the person sleeping lies against the net, then mosquitoes can bite through it. Bed nets coated with insecticide are a great improvement. The insecticide often has a repellent effect. The insecticide is deadly to mosquitoes. If a mosquito lands on the net, it will pick up the insecticide and die. Hanging an impregnated (coated with insecticide) bed net in a room will also protect people who are not sleeping under the net. After a blood meal, the mosquito is heavier and needs to rest to allow the blood to be digested. If the mosquito lands and rests on the net it will be killed, preventing it from infecting anybody else.

Long-lasting insecticidal nets are also available and don't require that their owners reapply insecticide. Pre-treated insecticide nets are available but require re-treatment every 4-6 months. Despite the extra work, it may be worthwhile to purchase untreated nets and treat them prior to use. The quantity and quality of insecticide on a pre-treated net varies from ineffective to effective. Bed nets should be re-impregnated every 4 to 6 months and after washing. Awareness and education is necessary to ensure that users re-impregnate their nets. It can be better to arrange a community approach to re-impregnation where large vats of insecticide are set up so that people can dip their nets and then take home to dry.

Chemical Methods

At the household level, insecticides can be used to deter and kill mosquitoes and other insects. A common approach is to apply an insecticide with a long-lasting effect to the interior walls of the home. When mosquitoes or other insects land on the walls they are killed by the insecticide. Indoor residual spray (IRS) insecticides need to be reapplied approximately every 6 months depending on the type of insecticide and the wall materials. IRS does not generally prevent people from being bitten, but it kills mosquitoes after they have fed and are resting.

Fogging and spraying insecticides over large areas is quite common in some countries, especially in urban areas. This can have an immediate and dramatic effect on the population of insects in an area. However, the insect population will quickly recover unless the fogging is repeated regularly. To be effective, the timing of the application must coincide with the period in the day when the target mosquitoes or insects are active, and it is most useful for mosquitoes and insects that spend most of their lives outside of buildings.

Larvicides can be applied to bodies of water and to containers of water in order to kill the mosquito larvae before they mature into mosquitoes. They are especially useful when dealing with "container breeding" mosquitoes, as breeding sites can be identified

and larvicides easily applied. Since many larvicides are not harmful to humans and other animals at the doses recommended, they are often used for treating drinking water storage containers and tanks.

Biological Methods

There are naturally occurring bacteria that act as larvicides and they are being sold commercially in an increasing number of regions. Biological methods are growing in popularity as they are seen to be safer and less environmentally threatening than the chemical products. However, there is concern that the long term effects of introducing new microorganisms into water and local environments are not fully understood.

Bacillus thuringiensis var. israelensis (Bti) is a type of bacteria which kills mosquito, black fly, and some other larvae. There is no evidence to suggest that it is harmful to humans, livestock or other aquatic creatures. However, its effectiveness is affected by the water quality factors such as high organic content, temperature and pH level. Bti has virtually no residual effect and therefore requires regular repeated applications.

Bacillus sphaericus (Bs) is another type of bacteria that can kill some species of mosquito larvae. It is generally effective against Anopheles and Culex larvae but not against Aedes or black fly larvae. It has a 2 to 4 week residual effect and is effective in water with high organic content although the residual effect is less.

Mosquito Coils

Using mosquito coils containing natural or synthetic insecticides and repellents is very common. The smoke produced when the coils burn has a repellent effect and can also kill mosquitoes. There is concern that long term daily use of these coils, especially in enclosed rooms, can contribute to lung disease. Coils can be useful for dealing with mosquitoes that bite in the evening and at dusk before people retire under their nets for the night.

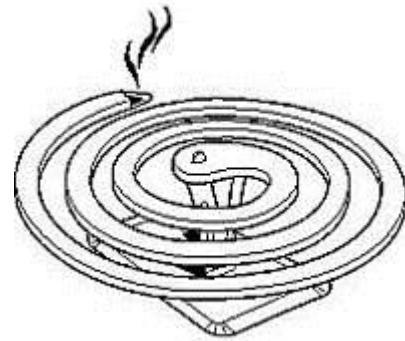

Mosquito Coil

Environmental Measures

Environmental measures to reduce breeding and resting sites for mosquitoes can be difficult to carry out effectively. The flight range of mosquitoes varies from 0.5 to several kilometres. In some areas there may only be a few locations within that 2 km radius where mosquitoes can breed and that may be fairly easy to deal with. However, in other areas there may be many thousands of mosquito breeding sites within a 2 km radius.

Environmental measures to reduce mosquito populations include:

- Proper wastewater disposal using soak pits or infiltration trenches
- Disposing of solid waste, especially items that can hold water such as cans, bottles, tires and plastic bags
- Putting screens on water storage containers and tanks
- Constructing and maintaining drainage channels to avoid flooding and stagnant water

- Clearing standing water (e.g. flower and plant pots that contain standing water, blocked gutters and drains, covered and screened latrines and septic tanks)

10.2 Flies

Flies play a role in transmitting many diarrheal diseases. They lay their eggs in organic matter that provide food for the emerging maggots. Excreta found in unsanitary latrines are ideal for this, as is domestic food waste that is not properly disposed of. Flies pick up pathogens on their bodies when laying their eggs or feeding and then transport it to people's food, tableware and faces.

Latrines which prevent flies and other insects from gaining access to the excreta or prevent them from exiting once inside can greatly reduce the volume of excreta that is flying around. If everybody in a community were to practice safe excreta disposal and proper waste management, the number and accessibility of breeding and feeding sites would be reduced. This would lead to a reduction in fly populations.

Flies also play a role in transmitting trachoma. Flies are attracted to eye discharge and land on the face of infected person, picking up the pathogen and transporting it to the eye of a new host. The disease is especially prevalent in areas where there are shortages of water, numerous flies and crowded living conditions. Primary interventions to prevent trachoma infection include proper disposal of human and animal waste, reduction of fly breeding sites and increased facial cleanliness (with clean water) among children at risk of disease. Good personal and environmental hygiene has been proven to be successful in reducing trachoma (WHO, 2001).

The use of insecticides--similar to those used for mosquito control--can also significantly reduce fly populations. Other methods to control flies include sticky fly papers and tapes and simple traps. Fly traps can be made from plastic bottles as shown in the following illustrations. When traps are full, the contents should be buried at least 15 cm below ground to prevent hatching larvae from emerging.

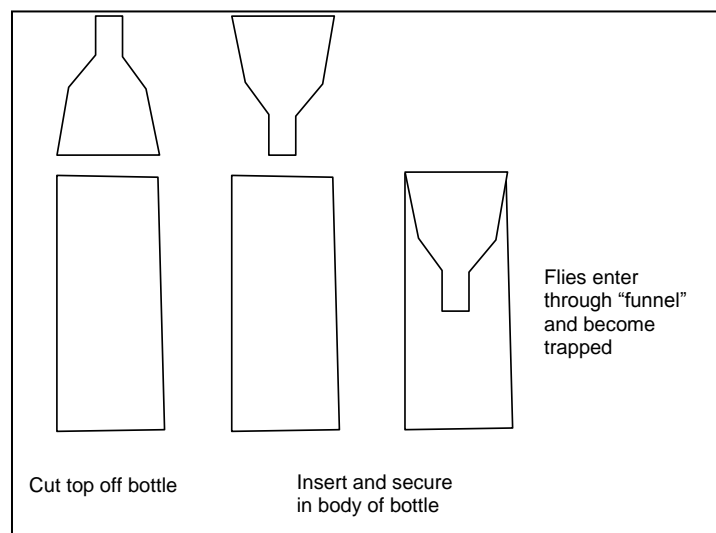
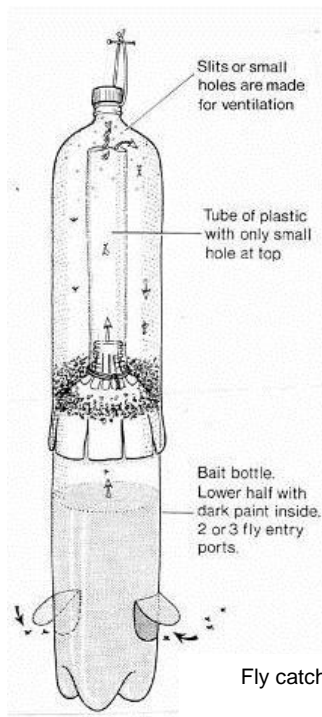

Plastic bottle fly catcher instructions

Fly catcher made from plastic water bottles
(Credit: Unknown)

10.3 Rodents

Rodents such as rats and mice transmit disease through a number of mechanisms, such as:

1. Direct contamination via dirt and feces carried on their body
2. Bites or scratches (e.g. Rat Bite Fever)
3. Fleas carried on their bodies that transmit Typhus and Plague
4. Rat urine that can transmit Hantavirus when inhaled. Droppings and urine that can transmit Lassa fever, Salmonella, and Leptospirosis



Rats and other rodents can find their way into homes and food and grain stores where they eat and destroy huge amounts of food annually. Controlling them reduces the risk of disease transmission and can also decrease food loss and spoiling.

10.3.1 *Passive Control Measures*

Prevention is better than cure. It is usually better and easier to prevent an infestation of rodents than to get rid of them once they are established. The number of rats and other rodents that are found in an area is closely linked to the availability of food, water and shelter. Properly disposing of domestic waste will remove an easily available food supply. As well, using rodent-proof storage containers will also limit the availability of food. Many traditional designs of grain stores have features that prevent rodents from entering the store. However, many modern grain stores do not have such protection.

Cutting grass and brush around buildings and keeping the surrounding area tidy and free of domestic waste can deter rodents from approaching a building as they prefer to move along dark, sheltered pathways.

The presence of cats or dogs (even just their scent) can deter rats and mice from entering a building and in some cases will even drive them out. All the better if the cats and dogs are natural hunters, however cats may be reluctant to attack a large adult rat.

Rodent-Proof Buildings

Ensuring that a building is rodent-proof is not an easy task. Rats and mice can pass through extremely small holes or a crack in the wall of a building (6 millimetres for a mouse, and 12 millimetres for a young rat). Therefore careful attention is necessary to ensure that all cracks and holes are filled. Rodents are powerful gnawers and if they are used to entering a building at a particular place, it may be necessary to reinforce any repairs with steel mesh to prevent them from chewing their way back inside again.

Other measures include:

- Fixing metal disks on cables and pipes entering a building to prevent rodents from crawling along them

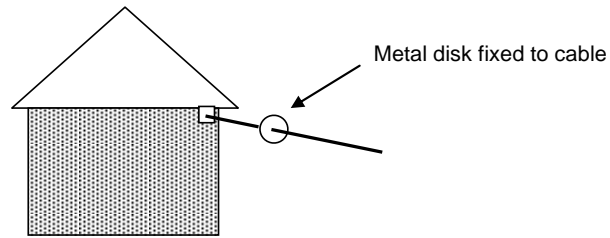

- Fixing steel sheeting to the bottom of doors and to the jamb to prevent gnawing of the edges

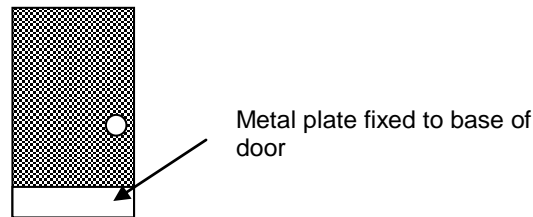

- If external walls have rough surfaces, plaster and/or paint a smooth band 1 metre high to create a slick surface to prevent rodents climbing up the walls

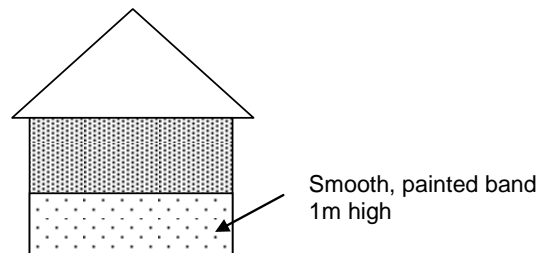

10.3.2 Active Control Measures

Plague and typhus are transmitted by the fleas normally carried on the bodies of rats. When a rat is killed its fleas will normally transfer to another rat. However, if large numbers of rats are killed at one time then there is a risk that the fleas will transfer to the nearest warm bodied creature, which may be a human. In plague or typhus endemic areas (i.e. places where plague and typhus are common), rats should be treated for fleas before any attempt is made to kill them. This can be done by dusting rat runs with a powdered insecticide (deltamethrine or similar). The rats pick up the powder on their lower bodies and on their feet and it is spread through their fur during grooming.

Rodents can be surprisingly intelligent and cautious animals and will often avoid traps laid for them. Traps and poison bait boxes placed in their environment will be investigated carefully and avoided if a trap harms a member of their pack. A form of "bait and switch" can be done to get rodents used to feeding at the traps or bait boxes. Traps are laid with food but are not set, and bait boxes are laid with poison-free bait. Once the rodents are used to feeding there, the traps are set and poisoned bait is placed in the bait boxes.

Traps and poison baits must be set in places where there is no danger to children or to domestic animals.

Mechanical spring traps are available everywhere in the world and are usually sized appropriately for the rats or mice found locally. They should be baited with foods that are familiar to the targeted rodent population.

Rodent glue is available in many parts of the world. This is a very sticky glue which is applied to pieces of board and placed along rat runs. The glue can also be baited. The rats and mice stick to the glue and can then be drowned or otherwise killed. The advantage of rodent glue is that it is non-toxic and safe to use in food storage and preparation areas.

Box or cage traps catch rats and mice alive. They can then be killed or, a more humane approach, the trapped rodents can then be released somewhere distant from human habitation.

A **pitfall trap** is a simple but effective trap that can be made from a bucket, a corn cob and a piece of wire. To attract rats, the corn cob can be smeared with peanut butter or similar food. The rat stretches over the bucket, places its front feet on the corn cob which spins around, and the rat falls into the bucket and drowns. The bucket should be wide enough to require a long, unbalanced reach to the bait, and it should be deep enough to prevent a rat from escaping once inside.

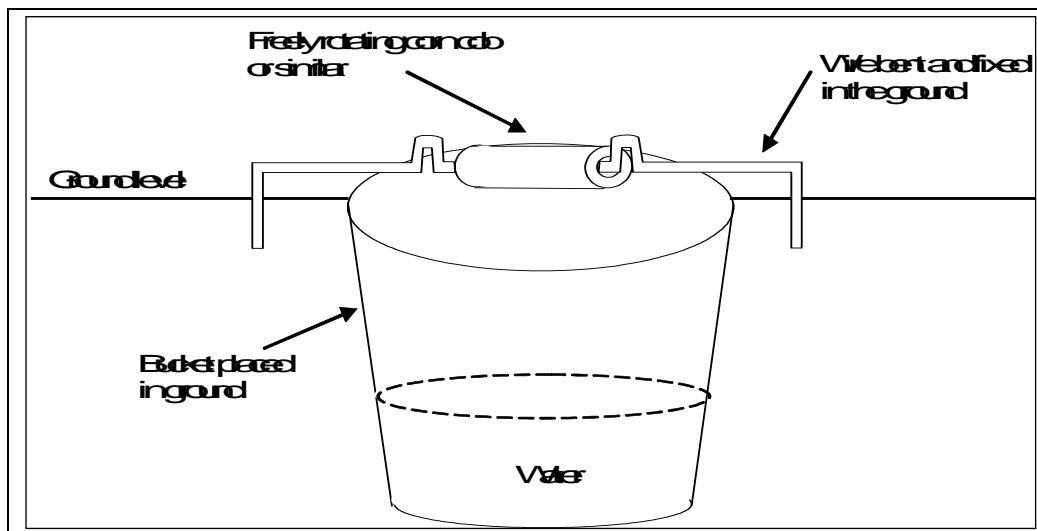

Rodenticides

There are many different types of rodenticides designed to kill rats and mice. The rodenticide is applied to food which acts as a bait to attract them. As previously mentioned, rats are cautious of new foods. They may try a small portion and then wait to see whether they become sick. Therefore it is important to:

- Use a bait and switch strategy
- Ensure that the rodenticide is tasteless and odourless
- Ensure that the poison has a delayed effect (at least 1 day, preferably longer)

Rodenticides and the bait food should be placed in bait boxes. These are boxes or tubes which contain the bait and prevent access to it by other animals or children. Bait boxes

should be placed along places where rats commonly run, or adjacent to areas where rodents are accustomed to feeding.

A problem with the use of rodenticides is that there is no control over the location that the rat or mouse dies. Unpleasant smells can result if they die in a nest that is inside a wall or ceiling of a home. Some rodenticides (e.g. anticoagulants) cause dehydration. This is done in the hope that the rodent will leave the building in search of water.

Another important consideration is that the body of the dead rodent will be poisonous. This can be an issue for communities which traditionally eat rodents and where scavenging dogs, cats and pigs may eat the dead rodents.

If a large rodent control campaign is planned, especially if rodenticides are to be used, then local pest control experts should be consulted for advice and guidance.

11 Review Activities

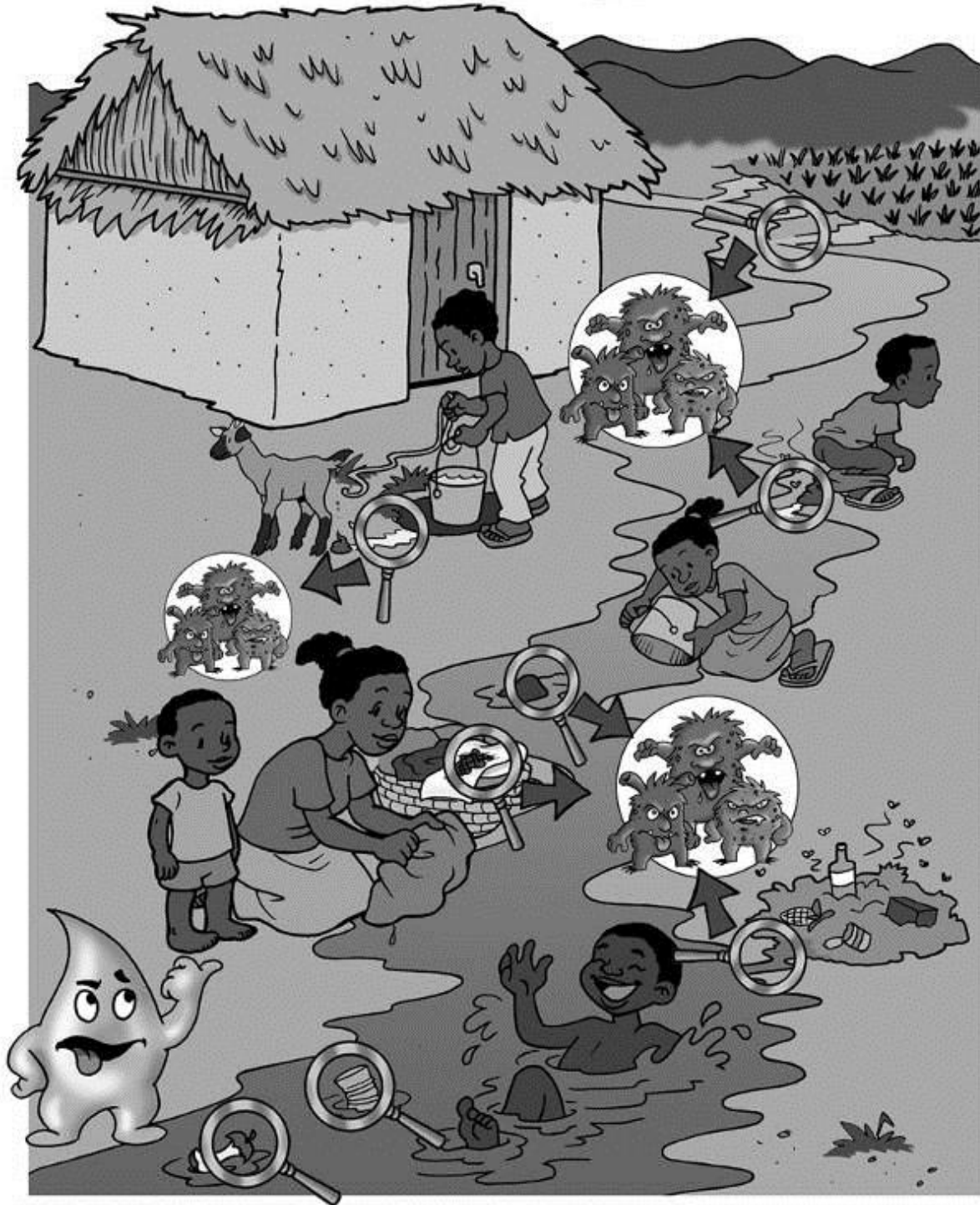

11.1 Shtole Case Study

Useful section references for completing this activity are "Factors Affecting Sanitation Choices" and "Siting Latrines".

Instructions: Read the following case study and work through the accompanying questions.

Part A

Introduction:

Shtole is a village in East Africa. The area is hilly and there is regular rain throughout the year. You carry out an assessment of the sanitation situation in the village and discover the following:

Health:

- Many of the children are often sick with diarrhea.

Drinking Water:

- Most of the residents take their drinking water from a 2.5 metre diameter well. The well is lined with dry-stone walling and fitted with a hand pump. The pump is well maintained.
- Some of the residents collect their drinking water from a protected spring about 1 km from the village.

Sanitation:

- All householders have latrines within their compounds. The quality of the latrines varies. Some are simple pit latrines with slabs made from wooden poles and earth, and with grass walls for the superstructure. Others are brick VIP latrines.
- You discover four latrines in compounds directly next to the well. The latrines are less than 15 metres away from the well.

a. What information do you still need?

b. How will you gather that information?

Part B

After further investigation, you find out the following information:

Health:

- The families collecting drinking water from the spring report that their children rarely have diarrhea.

Drinking Water:

- The well is 4 metres deep.
- The water level in the well is 2 metres below ground level.
- 50 families use the well and it never dries up.

Sanitation:

- The latrines are used.
- All the latrine pits are 2.5 metres deep.
- By looking, the distance from the slab to the top of the contents in the pit is about 1.5 metres.
- Ground level at two of the latrines is 1.5 metres above the well

Soil:

- The soil looks like it is a light, sandy soil. Residents say the ground is easy to dig but that groundwater prevents digging very deep. The good flow of water into the well (it never goes dry) suggests the ground is quite permeable.

a. What is the most important information that tells you there may be a problem with the location of the latrines?

b. What are the options for solving the problem?

c. What do you advise and why? Short term? Mid term? Long term?

11.1.1 **Shitole Case Study – Solutions**

Part A

- a. What information do you still need?**
- *Check the situation and determine if there is an unacceptably high risk of contamination.*
- b. How will you gather that information?**
- *Check if the latrines are used*
 - *Check depth of well and water level*
 - *Check depth of latrines (if possible)*
 - *Check type of soil in area*
 - *Check for any major difference in elevation between well and latrines*
 - *Check direction of groundwater flow*
 - *Ask families that collect drinking water from the spring if their children often have diarrhea*

Part B

- a. What is the most important information that tells you there may be a problem with the location of the latrines?**
- *Families using the spring do not report frequent diarrhea*
 - *Shallow ground water*
 - *Porous soil, easy flow of ground water*
 - *Latrines are higher than the well*
 - *Latrine contents are below ground water level*
 - *Distance between latrines and well*
- b. What are the options for solving the problem?**
- *Move the well*
 - *Abandon the well and switch to rainwater catchment and storage*
 - *Relocate the four latrines to a safe distance*
 - *Organize bucket chlorination at the well*
 - *Household water treatment*
 - *Construct sanitary spring box and pipe water to village.*
- c. What do you advise, and why? Short term? Mid term? Long term?**
- *Short term – organize bucket chlorination at well.*
 - *Short term – introduce household water treatment.*
 - *Mid term – relocate the four latrines to a safe distance from the well. Empty latrines to reduce the presence of contamination close to the well.*
 - *Long term – capture spring and pipe water to village.*

11.2 Kashgar, Xinjiang, China Case Study

It is best to do this case study after reading the entire manual.

Instructions: Read the following case study and work through the accompanying questions.

Introduction:

Kashgar is located on the west edge of the Taklimakan Desert, China. The population is mainly Muslim Uighur people.

- The government has installed an extensive irrigation system. Most of the rural population grows cotton on the irrigated land.
- They also have some land for their own purposes, usually used for growing vegetables.

A rapid assessment in nearby villages has shown that water and sanitation practices pose a health risk:

Sanitation:

- Most compounds have a shallow excavation next to the house. This pit is used as the household toilet, and also for disposal of domestic solid waste and animal waste. The pit is about 2 metres wide, 2 metres long and 0.5 metres deep.
- There are many flies in and around the pits, and the smell is very bad. The residents say they don't think this is a problem.
- Pits are emptied by hand once or twice per year. The contents dug out of the pit are used as fertilizer.

Drinking Water:

- Water for drinking and domestic uses is taken from open irrigation channels. The water in these channels is pumped from deep, high capacity wells.
- There are one or two boreholes with handpumps in each village. This water is used for domestic purposes, mainly by the people living next to the pumps.

a. List the main concerns.

b. What are the options for improving the situation?

11.2.1 *Kashgar, Xinjiang, China Case Study – Solutions*

a. List the main concerns.

- *Defecation practice leaves excreta open to the environment.*
- *Many flies present*
- *Handling of fresh excreta*
- *Fresh excreta applied to crops (precious resource therefore most likely the vegetable crops)*
- *Water supply quality is very precarious*
- *Few people make use of (probably) safer handpump water supply.*
- *Cotton notorious for high use of agrochemicals—contamination of handpump water supply?*

b. What are the options for improving the situation?

- *Encourage safer practices for handling fresh excreta.*
- *Introduce sanitary composting latrines.*
- *Install biosand filters to improve the quality of water collected from channels.*
- *Install more convenient located handpumps.*

11.3 Urbanizacao, Maputo, Mozambique Case Study

It is best to do this case study after reading the entire manual.

Instructions: Read the following case study and work through the accompanying questions.

Introduction:

Urbanizacao is a long established yet unplanned bairro of Maputo city. The residents are a mixture of working class through to lower middle class. During cholera outbreaks, Urbanizacao has always been one of the worst affected bairros of the city.

A preliminary assessment shows that:

General:

- Most housing is of a reasonable standard — brick/concrete blocks and corrugated sheeting roofs. All except the very poor have an electricity supply.
- The soil is very sandy.
- The water table is shallow.
- Flooding is common during the rainy season
- Flooding is made worse by a lack of drainage. There are very few surface water drainage channels inside the bairro. On the edges of the bairro, large channels that do exist are blocked with waste.
- There is no waste collection service. Solid waste must be carried to skips (dumpsters) located at the edge of the bairro. Unsurprisingly, waste is spread along the roads and paths of the bairro.
- There is little support from the government for infrastructure improvements.

Water Supply:

- Water is supplied to public tap stands. The supply to public tap stands is free, and is relatively reliable but it is intermittent.
- Some houses have connections from the city's piped network.

Sanitation:

- All houses have latrines of some sort. Open defecation is very rare.
- Some houses have flush toilets with septic tanks and soak pits.
- Many of the latrine pits are very small and shallow. They are often lined with an old oil drum and use a tire on top as the squatting slab.
- Most householders pay to have their latrines emptied.
- Latrines are emptied by hand, usually with a hand shovel and a bucket. Pit contents are then buried in a shallow excavation next to the latrine.

a. List the main concerns.

b. What would you advise for reducing water, hygiene and sanitation related diseases (especially cholera) and for improving living conditions in the bairro?

11.3.1 Urbanizacao, Maputo, Mozambique Case Study – Solutions

a. List the main concerns.

- *Lack of consistent water supply*
- *Small latrine pits with poor pit wall support*
- *Hand emptying of latrine pits; possible contact with contents after they are buried (shallow)*
- *Blocked drains*
- *No waste collection/disposal*

b. What would you advise for reducing water, hygiene and sanitation related diseases (especially cholera) and for improving living conditions in the bairro?

- *Community management system with hygiene and sanitation promotion activities.*
- *Negotiate with water company for better supply; consider introducing a system of payment for water distributed at public tapstands as a trade off for improved supply*
- *Lower the tapstand outlets (30 centimetre reduction could make a big difference)*
- *Introduce permanent latrines e.g. honeycomb brick walling for pit support, deeper excavations (shoring/caissoning), and permanent easily cleaned slabs.*
- *Introduce sanitary pit emptying service employing current pit emptiers – vacuum pumps, sanitary storage, transport and disposal.*
- *Investigate the appropriateness of introducing small bore sewerage (needs water supply!!).*
- *Introduce intra-bairro waste collection service using handcarts to collect and transport waste from houses to the municipal dumpsters. Possibly include payment for service as a supplement on the electricity bill.*
- *Consider improving the drainage system. Expand system of small local channels to carry water out of the bairro to the perimeter drains: clean*

11.4 Tal Camp, Bangladesh Case Study

It is best to do this case study after reading the entire manual.

Instructions: Read the following case study and work through the accompanying questions.

Introduction:

Tal Camp is a recent Muslim refugee settlement in southern Bangladesh. An assessment shows that:

General:

- The camp is located on a very thin strip of land that is sandwiched between the main road and the Naf River. The land is only 30 to 60 metres wide at its narrowest point.
- The Naf River is tidal. The land and buildings closest to the river flood every day with the high tide.
- Most housing is of very poor quality. Walls and roofs of dwellings are made from cardboard, grass, leaves and plastic sheeting.
- Virtually all available space is taken up by the dwellings and the small pathways between them.
- There is no electricity, no water supply in the camp, and the latrines are full and overflowing.
- There is no waste collection service.
- The water table is very shallow.
- During the rainy season flash floods are common.
- Drainage channels in the camp meander around dwellings. They are unmaintained and blocked with waste.
- There are many flies, mosquitoes and rats, and all residents complain about the discomfort and nuisance that they cause.
- There is no convenient access to services such as education, health care, police, etc.
- There is little or no support from local government or UNHCR.
- Almost all camp residents survive on less than \$1 per day. Malnutrition is common in both children and adults.

Water Supply:

- Water is available from a pond approximately 1km away.
- In the same area, there are also 2 hand dug wells and 4 tubewells (on private property) that some camp residents can access.
- During the rainy season water collects in small, very shallow “wells” excavated on the other side of the road from the camp, which some residents can access.

Sanitation:

- Some latrines were constructed when the residents first settled. These latrines are located between the houses and the river. The tide comes up to the latrines every day.
- The latrine pits are made from 3 to 4 partially buried concrete rings, with slabs mounted on top of the rings. The rings are mostly above ground, and have been uncovered and broken open to allow the latrine contents to flow out to the river with each tide.
- Due to the condition of the latrines, most residents do not use the latrines. They defecate on Forest Reserve land on the other side of the road.

a. List the main concerns.

b. What would you advise for reducing water, hygiene and sanitation related diseases, and for improving living conditions in the camp?

11.4.1 **Tal Camp, Bangladesh Case Study – Solutions**

a. List the main concerns.

- *Extremely poor, vulnerable and neglected community*
- *Poor water quality and lack of water*
- *Little or no proper sanitation*
- *Open defecation is common*
- *Parts of camp flooded on a daily basis*
- *Excreta washed in and out of the camp continuously*
- *Very shallow ground water*
- *Drainage channels unable to cope with flash floods*
- *Environment ideal for breeding vectors*

b. What would you advise for reducing water, hygiene and sanitation related diseases, and for improving living conditions in the camp?

- *Advocate moving the camp to a more suitable location.*
- *Contact other NGOs to assist the residents with feeding, nutrition support, medical treatment, schooling and education.*

- *Open defecation*
 - *Organize teams to collect excreta from open areas.*
 - *Organize defecation areas, and encourage use of cat latrines.*

- *Full latrines*
 - *Empty and repair if possible.*
 - *Bury latrine contents, preferably outside the camp.*

- *Improve facilities*
 - *Construct septic systems with tanks above ground.*
 - *Use modified 5 to 10 cubic metre plastic tanks as septic tanks*
 - *Connect to water seal latrines*
 - *Discharge waste water to river beyond tidally exposed area*
 - *Install tanks at accessible locations to allow sludge to be removed.*

- *Negotiate with Forestry Department to construct latrines on higher ground on opposite side of the road (Good luck!)*

- *Hygiene*
 - *Conduct appropriate hygiene sessions with children, adolescents and adults.*

Solution continued:

- *Water supply*
 - *Introduce household water treatment*
 - *Initially settlement and disinfection*
 - *Consider filters at later date*

- *Waste management*
 - *Install bins at convenient locations in camp.*
 - *Clear waste from drainage channels, pathways, etc.*
 - *Organise team to empty bins and bury the waste.*

- *Wastewater and drains*
 - *Re-excavate drainage channels to ensure they are as straight as possible.*
 - *Clear solid waste from drains and maintain them.*

- *Vector control*
 - *Ensure waste water is drained away rapidly*
 - *Clear and fill any depressions where water collects and stagnates.*
 - *Ensure solid waste is removed on a daily basis.*
 - *Consider insecticide residual spraying in dwellings*
 - *Consider rodent control using traps and bait.*

12 References

- Adams, J., Bartram, J., Chartier, Y. and J. Sims. (2009). Water, Sanitation and Hygiene Standards for Schools in Low Cost Settings. World Health Organization, Washington, DC, USA. Available online at:
www.who.int/water_sanitation_health/publications/wsh_standards_school/en/index.html
- Akvopedia (2009). Application of Compost – Eco-Humus. Akvo, The Hague, The Netherlands. Available at:
www.akvo.org/wiki/index.php/Application_of_Compost_-_Eco-Humus
- Bahuguna, N. J. (nd). Walk of Shame Triggers Toilet Consciousness. UNICEF India. Available at: www.unicef.org/india/wes_2920.htm
- Bickel, S. (1996). Environmental Guidelines for Small Scale Activities in Africa. Chapter 15 – Solid waste: generation, handling, treatment and disposal. Bureau for Africa's Office of Sustainable Development. Available at:
www.encapafrika.org/egssaa.htm
- Buttle, M, Michael Smith. (2004). Out in the Cold: Emergency Water Supply and Sanitation for Cold Regions. WEDC, Loughborough University, UK.
- Cairncross, S. (2004). The Case for Marketing Sanitation. Water and Sanitation Program. Nairobi, Kenya. Available at: www.wsp.org
- Chatterton, K. (nd). Womens hygiene unit 35 EDIE. WEDC. Available at:
<http://wedc.lboro.ac.uk/>
- Courvallet, M, Delmas, G,. (1994). Public Health Engineering in Emergency Situations. Médecins sans Frontières (MSF). Paris, France.
- Davis, J. and B. Lambert (1995). Engineering in Emergencies: A Practical Guide for Relief Workers. Second Edition. RedR/IT Publications, London, UK.
- Dueñas, M. (2009). Floating Toilets for Floating Villages. Asian Development Bank. Available at: www.adb.org/Water/Champions/2009/Sahari-Ani.asp and <http://washtech.wordpress.com/2009/03/01/floating-toilets-for-floating-villages-on-cambodias-tonle-sap-lake/>
- EAWAG & WSSCC. (2000). Summary Report of Bellagio Expert Consultation on Environmental Sanitation in the 21st Century. Swiss Federal Institute for Environmental Science and Technology. Switzerland.
- Esrey, S.A., J.B. Potash, L. Roberts, C. Shiff. (1991). Effects of Improved Water Supply and Sanitation on Ascariasis, Diarrhoea, Dracunculiasis, Hookworm Infection, Schistosomiasis, and Trachoma. *Bull. Wild Health Orgn.* 69(5):609-621.

- Furedy, C. (1999). Reflections on Some Dilemmas Concerning Waste Pickers and Waste Recovery. Prepared for Urban Waste Expertise Programme of WASTE, May 1997; published in Source Book for UWEP Policy Meeting 1997. Revised April 1999. Available at: www.yorku.ca/furedy/papers/wpick.htm
- Harvey, P. (2007). Excreta Disposal in Emergencies: A Field Manual. WEDC, Loughborough University, UK. Available at: www.wedc-knowledge.org/wedcopac/opacreq.dll/fullnf?Search_link=AAAA:M:218421842887
- Hoorweg, D. and L. Thomas (1999a). What a Waste: Solid Waste Management in Asia. The World Bank, Washington, DC, USA. Available at: www.worldbank.org/urban/solid_wm/erm/CWG%20folder/uwp1.pdf
- Hoorweg, D., Thomas, L. and L. Otten (1999b). Composting and its Applicability in Developing Countries. Urban Waste Management, Working Paper Series, 8. The World Bank, Washington, DC, USA. Available at: www.worldbank.org/urban/solid_wm/erm/CWG%20folder/uwp8.pdf
- Erich Sachs, S, Kiszewski, A, Malaney, P, Mellinger, A, Spielman, A, Sachs, J. (2004). A Global Index Representing the Stability of Malaria Transmission. American Journal of Tropical Medicine and Hygiene. 70(5) 486-498. New York, USA. Available at: www.ajtmh.org/cgi/content/full/70/5/486
- Kool, R. (2010). Moving Learners to Action: A review of current research, and implications for your environmental education program Workshop. Interview. Canada.
- Lifewater International. (2009). Sanitation Latrine Design and Construction. California, USA.
- Mazumdar, I., (1992). India. Warmer Bulletin 34, August, p. 3.
- Merlin. (2002). Integrated Emergency Sanitation Project. Wajir, Kenya.
- Nam Saat Central (2001). Towards Better Hygiene and Behaviour Change for the Rural Water Supply and Sanitation Sector in Lao PDR. Vientiane, Lao PDR. November 2001.
- Network Learning (2003). Health Education for Behaviour Change: A Workbook to Improve Skills. Available at: www.networklearning.org
- Ogawa, H. (1996). Sustainable Solid Waste Management in Developing Countries. Presented at the 7th ISWA International Congress and Exhibition, Parallel Session 7, "International Perspective". WHO Western Pacific Regional Environmental Health Centre (EHC), Kuala Lumpur, Malaysia. Available at: www.gdrc.org/uem/waste/swm-fogawa1.htm

- Oldfield, J. (2007). Community-Based Approaches to Water and Sanitation: A Survey of Best, Worst, and Emerging Practices. Available at: www.wilsoncenter.org/topics/pubs/WaterStoriesCommunity.pdf
- Pickford, J. (1995). Low-Cost Sanitation: A Survey of Practical Experience. Intermediate Technology Publications. London.
- Prüss-Üstün and Corvalan. (2006). Preventing Disease Through Healthy Environments: Towards an Estimate of the Environmental Burden of Disease. WHO. Available at: www.who.int/quantifying_ehimpacts/publications/preventingdisease/en/
- Reed, B., Scott, R. (2006). WELL Factsheet: Emptying Pit Latrines. WELL. Available at: www.lboro.ac.uk/well/resources/fact-sheets/fact-sheets-htm
- Rogers, E. (1995). Diffusion of Innovations (4th edition). The Free Press. New York
- Saïd Business School, University of Oxford (2010). Available at: www.sbs.ox.ac.uk/newsandevents/Pages/sanitarycareghana.aspx
- Shaw, R. (2005). Drawing Water: A resource book of illustrations on water and sanitation in low-income countries. WEDC, Loughborough University, UK.
- Scott, B. (2005). WELL Factsheet: Social Marketing: A consumer-based approach to promoting safe hygiene behaviours. WELL. Available at: www.lboro.ac.uk/well/resources/fact-sheets/fact-sheets-htm
- Scott, R. (2007) WELL Briefing Note 27. Should Ecological Sanitation Carry a Health Warning? WEDC, Loughborough University, UK. Available at: www.lboro.ac.uk/well/resources/publications
- Stockholm Environment Institute (2008). Guidelines for the Safe Use of Urine and Faeces in Ecological Sanitation Systems, EcoSanRes Factsheet 5. Stockholm Environment Institute, Stockholm, Sweden. Available at: www.sei.se
- Sugden, S. (2006). The Microbiological Contamination of Water Supplies, WELL Factsheet. WEDC, Loughborough University, UK. Available at: www.lboro.ac.uk/well/resources/fact-sheets/fact-sheets-htm/Contamination.htm
- Tchobanoglous, G., Theisen, H. and S. Vigil (1993). Integrated solid waste management: engineering principles and management issues. McGraw Hill, New York, USA.
- United Nations Children's Fund (UNICEF) (1997). Towards Better Programming: A Sanitation Handbook. Available at: www.unicef.org/wes/files/San_e.pdf
- UNICEF (1999). Towards Better Programming: A Manual on Hygiene Promotion. Available at: www.unicef.org/wes/files/hman.pdf

- United Nations Children's Fund (2009). Water, Sanitation and Hygiene in Schools. Available at: www.unicef.org/wash/index_schools.html
- UNICEF, WHO, UNESCO, UNFPA, UNDP, UNAIDS, WFP and the World Bank. (2002). Facts for Life: A Communication Challenge. Third ed. New York, UNICEF
- United Nations Development Fund (UNDP). (2006). Human Development Report 2006. Beyond Scarcity: Power, Poverty and the Global Water Crisis. Chapter 3: The Vast Deficit in Sanitation. Pgs.111-129. Available online at: <http://hdr.undp.org/en/reports/global/hdr2006/chapters/>
- UN-Water. (2009). Sanitation for All: A Wise Investment for Health, Dignity and Development. Available at: www.wsscc.org.
- Village Education and Resource Centre (nd). Achieving 100% Sanitation. Bangladesh
- WaterAid Nepal. (2006). Community Led Total Sanitation: Getting us back on track. WaterAid. Nepal. Available at: www.wateraid.org
- Wood S, Sawyer R, Simpson-Hebert M. (1998). PHAST step-by-step guide: a participatory approach for the control of diarrhoeal disease. WHO. Geneva. Available at: www.who.int/water_sanitation_health/hygiene/en/
- World Bank (2002). Hygiene Promotion in Burkina Faso and Zimbabwe: New Approaches to Behaviour Change. Field Note 7, Water and Sanitation Program, Africa Region. August 2002. Available at: www.gtz.de/ecosan/download/WSP-hygiene-promotionin-burkinafaso-zimbabwe.pdf
- World Bank. (2005). The Handwashing Handbook: A guide to developing a hygiene promotion program to increase handwashing with soap. World Bank. Washington DC, USA. Available at: http://esa.un.org/iys/docs/san_lib_docs/Handwashing_Handbook.pdf
- World Health Organization (WHO). (1997). Health And Environment In Sustainable Development: Five Years After the Earth Summit (unpublished).
- World Health Organization (2001). Water-related Diseases, Trachoma. World Health Organization, Geneva, Switzerland. Available at: www.who.int/water_sanitation_health/diseases/trachoma/en/index.html
- World Health Organization (WHO). (2002). Environmental Health in Emergencies and Disasters. WHO. Available at: www.who.int/water_sanitation_health/hygiene/emergencies/emergencies2002/en
- World Health Organization (2004). The World Health Report 2004: Changing History. World Health Organization, Geneva, Switzerland. Available at: www.who.int/whr/2004/en/

World Health Organization (2006). Guidelines for the Safe Use of Wastewater, Excreta and Grey Water World Health Organization, Geneva, Switzerland. Available at: www.who.int/water_sanitation_health/wastewater/en/

WHO & UNICEF. (2008). Progress on Drinking Water and Sanitation: Special Focus on Sanitation. WHO/UNICEF Joint Monitoring Programme for Water Supply and Sanitation (JMP) Report.

WHO & UNICEF JMP. (2010). Progress on Sanitation and Drinking-Water. WHO/UNICEF Joint Monitoring Programme for Water Supply and Sanitation (JMP Report). Available at: www.wssinfo.org/

Notes

Notes

Notes

Notes