

Coronavirus disease 2019 (COVID-19) caused by a Novel Coronavirus (SARS-CoV-2)

Guidelines for case-finding, diagnosis, and public health response in South Africa

Compiled by

**the Centre for Respiratory Diseases and Meningitis (CRDM) and Outbreak Response Unit, Division of
Public Health Surveillance and Response, National Institute for Communicable Diseases (NICD) of the
National Health Laboratory Services (NHLS)**

and

the National Department of Health, Republic of South Africa

Version 3.1

Guidelines writing committee (in alphabetical order):

Ahmed Bham (National Department of Health (NDoH), Emergency Medical Services (EMS))

Jinal Bhiman ((National Institute for Communicable Diseases (NICD); Centre for Respiratory Diseases and Meningitis (CRDM))

Funeka Bongweni (NDoH, Port Health)

Lucille Blumberg (NICD, Division of Public Health Surveillance and Response (DPHSR))

Cheryl Cohen (NICD, CRDM)

Linda Erasmus (NICD, DPHSR)

Nelesh Govender (NICD, Centre for Healthcare-Associated Infections, Antimicrobial Resistance and Mycoses)

Nevashan Govender (NICD, DPHSR)

Jackie Kleynhans (NICD, CRDM)

Ann Mathews (NICD, DPHSR)

Kerrigan McCarthy (NICD, DPHSR)

Meredith McMorrow (U.S. Centers for Disease Control and Prevention (CDC))

Jeremy Nel (Helen Joseph Hospital)

Genevieve Ntshoe (NICD, DPHSR)

Wayne Ramkrishna (NDoH)

Stefano Tempia (CDC)

Sibongile Walaza (NICD, CRDM)

Nicole Wolter (NICD, CRDM)

Guideline review:

This version (3.0) approved by:



Date: 2 July 2020

Summary of changes:

| Version | Date reviewed | Revised by | Summary of changes | New version |
|---------|---------------|---------------------------|--|-------------|
| 1.0 | 26 Feb 2020 | S. Walaza and M. McMorrow | <ul style="list-style-type: none">• 2019 nCoV changed to COVID-19 or SARS-CoV-2 as appropriate• Updated case counts, etc.• Updated contributors• Updated case definition to add fever, pneumonia of unknown aetiology and | 1.1 |

| | | | | |
|-----|---------------|---|---|-----|
| | | | <p>countries with community transmission of COVID-19</p> <ul style="list-style-type: none"> • Update information on packaging of specimens-triple packaging only applicable to international specimens) • Additional information on differential diagnosis and treatment added | |
| 1.1 | 8 Mar 2020 | S. Walaza and M. McMorrow | <ul style="list-style-type: none"> • Updated general epidemiologic information on outbreak • Updated information on first confirmed cases in South Africa • Clarified that contact information should be collected from contacts from the date of symptom onset • Updated referral hospital list | 2.0 |
| 2.0 | 10 Mar 2020 | M. McMorrow | <ul style="list-style-type: none"> • Minor update to case definition | 2.1 |
| 2.1 | 10 April 2020 | S. Walaza, N. Govender, N. Wolter and M. McMorrow | <ul style="list-style-type: none"> • Updated case definition to remove requirement for contact of case, travel history, admission or healthcare exposure • Updated laboratory contacts for provincial NHLS laboratories and submission forms • Updated IPC guidance to include N95 masks for aerosol-generating procedures: intubation, bronchoscopy, and CPR • Close contact definition updated to 2 days prior to symptom onset in the index case | 3.0 |
| 3.0 | 25 June 2020 | L Erasmus, K McCarthy, M McMorrow, N Wolter | <ul style="list-style-type: none"> • Updated case definition including anosmia, dysgeusia, fever not essential, removed persons at highest risk • Updated preferred specimen type, transport and storage • Added reference to COVID-19 Disease-Infection Prevention and Control Guidelines • Added collection and submission of postmortem specimens from deceased | |

| | | | | |
|-----|-------------|--|--|--|
| | | | <p>known or suspected COVID-19 cases with reference to CDC guidance document</p> <ul style="list-style-type: none"> • Amended repeat sampling particularly for hospitalised patient where management may be significantly altered • Added: Repeat testing not needed for de-isolation • Contact tracing decentralised to province/district • Added reference to Guidelines for symptom monitoring and management of essential workers for COVID-19 related infection • Added link to NMC notification • New COVID-19 NMC case notification form replaces PUI form • Added section on recording/reporting tools with definition of “recovered” for surveillance • Remove NICD specimen collection form (was Appendix 6) • Remove PUI form (was Appendix 7) • Remove Appendix 12: Guidelines for safe handling of human remains of confirmed/suspected COVID-19 • Move Appendix 13 to a separate document • Updated contact details (Appendix 10) • Added reference to Guidelines for symptom monitoring and management of essential workers for COVID-19 related infection | |
| 3.1 | 18 Aug 2020 | L Erasmus, K McCarthy, M McMorrow, N Wolter | <ul style="list-style-type: none"> • Updated isolation period for those who test positive from 14 days to 10 days • Updated quarantine period from 14 days to 10 days • Clarified close vs. casual contact definitions | |

| | | | | |
|--|--|--|--|--|
| | | | <ul style="list-style-type: none"> • Updated close contact definition to indicate exposures 2 days prior to symptom onset or while symptomatic • Updated contact tracing line list to clarify close contact case definition as ≤ 1 metre • State that casual contacts do not require daily monitoring as part of contact tracing but should be informed of potential exposure and encouraged to seek testing if they develop symptoms | |
|--|--|--|--|--|

Disclaimer

The information contained in this document, be it guidelines, recommendations, diagnostic algorithms or treatment regimens, are offered in this document in the public interest. To the best of the knowledge of the guideline writing team, the information contained in these guidelines is correct. Implementation of any aspect of these guidelines remains the responsibility of the implementing agency in so far as public health liability resides, or the responsibility of the individual clinician in the case of diagnosis or treatment.

Coronavirus disease 2019 (COVID-19) Quick Reference for Health Workers

National Institute for Communicable Diseases (NICD)

24-hour hotline number: 0800 11 1131|066 562 4021

Clinical presentation and management of suspected cases

The clinical spectrum of COVID-19 ranges from an asymptomatic or mild flu-like illness to a severe pneumonia requiring critical care. The most common clinical signs and symptoms are fever and cough with a few patients presenting with difficulty in breathing and bilateral infiltrates on chest X-rays. Treatment is supportive. The differential diagnosis for this syndrome is broad. Consider the possibility of influenza (Southern Hemisphere influenza season will begin in May or June), bacterial pneumonia, tuberculosis, *Pneumocystis jirovecii* (PCP) if immunosuppressed, and manage accordingly. Refer to NICD website <https://www.nicd.ac.za/diseases-a-z-index/covid-19/covid-19-guidelines/clinical-management-of-suspected-or-confirmed-covid-19-disease/>

Suspected COVID-19 case definition

Any person presenting with an acute (≤ 10 days) respiratory tract infection or other clinical illness compatible with COVID-19, or an asymptomatic person who is a close contact^a of a confirmed^b case

- Symptoms include ANY of the following respiratory symptoms: cough, sore throat, shortness of breath, anosmia (loss of sense of smell) or dysgeusia (alteration of the sense of taste), with or without other symptoms (which may include fever, weakness, myalgia, or diarrhoea)
- Note: Asymptomatic close contacts should not be routinely tested despite meeting the suspected case definition. However, testing may be indicated in certain circumstances (e.g. institutions such as care homes)

^a**Close contact:** A person having had face-to-face contact (≤ 1 metre) or been in a closed space with a confirmed case for at least 15 minutes. This includes, amongst others, all persons living in the same household as a case, and people working closely in the same environment as a case. Healthcare workers or other people providing direct care for a case, while not wearing recommended personal protective equipment or PPE (e.g., gowns, gloves, N95 respirator, eye protection). A contact in an aircraft sitting within two seats (in any direction) of the case, travel companions or persons providing care, and crew members serving in the section of the aircraft where the case was seated.

^b**Confirmed case:** A person with laboratory confirmation of SARS-CoV-2 infection (using an RT-PCR assay), irrespective of clinical signs and symptoms. Symptomatic cases are considered infectious from 2-3 days before symptom onset up to 10 days after symptom onset.

Infection prevention and control (IPC) (Page 10)

1. Patients meeting the suspected case definition should be asked to wear a surgical mask once identified
2. Suspected case should be isolated and evaluated in a private room
3. Limit patient movement (e.g., portable X-ray)
4. HCWs should wear appropriate PPE:
 - Eye protection (goggles or visor)
 - Gloves
 - Apron or gown
 - Surgical mask for general patient interactions, or N95 respirator (or equivalent, e.g., FFP2 mask) for aerosol-generating procedures such as specimen collection

Specimens required for SARS-CoV-2 PCR testing (Page 10/11 & App 3/4)

Collecting a good quality specimen is vital

1. Upper respiratory tract specimen for all patients
 - A single nasopharyngeal swab is the preferred sample type. When not possible, a single nasal mid-turbinate swab, nasal or oropharyngeal swab may be collected
 - Transport and store swabs in universal/viral transport medium (UTM) or sterile saline, between 2-8°C. If UTM is not available, use dry swabs in a sterile tube. Dry swabs can be sent at ambient temperature, but must reach the laboratory within 2 days
2. Lower respiratory tract specimen when available
 - Sputum (if produced – do NOT induce), tracheal aspirates or bronchoalveolar lavage
 - Transport in standard specimen container. Does not require UTM

*Note: lower respiratory tract samples may have higher sensitivity than upper respiratory tract samples and **should be collected for severe cases***

Case notification (for all confirmed cases) (Page 14)

COVID-19 is classified as a Category 1 notifiable medical condition (NMC). Therefore, notification of probable and confirmed cases should be made immediately, using the NMC web portal, mobile app (preferred methods), or NMC paper-based reporting form. Contact tracing will be initiated for confirmed COVID-19 cases.

Table of Contents

| | | |
|-----|--|-------------------------------------|
| 1 | Introduction | 8 |
| 2 | Microbiology and epidemiology | 8 |
| 3. | Clinical presentation and management | 9 |
| 4. | Case definitions for COVID-19..... | 10 |
| | Who should be tested for SARS-CoV-2? | 10 |
| 5. | Clinical management of COVID-19..... | 11 |
| 6. | Infection control..... | 11 |
| | Patients with suspected COVID-19 cared for in the home environment | 11 |
| 7. | Laboratory diagnosis..... | 11 |
| | What investigations should be done?..... | 12 |
| | Specimen collection and transport | 12 |
| | Laboratory diagnostic assays and interpretation of results | 14 |
| | Repeat testing is not indicated to de-isolate a patient:..... | 15 |
| 8. | Public health response | 15 |
| | Response to a suspected case | 15 |
| | Public Health response to a confirmed case..... | 15 |
| | Contact tracing..... | 16 |
| | Quarantine | 18 |
| 9. | Recording and Reporting | 18 |
| | COVID-19 definition of RECOVERED | 19 |
| | Management of the deceased | 20 |
| 10. | References | 21 |
| 11. | Additional Resources | 23 |
| 12. | Appendices..... | 24 |
| | Appendix 1: Process flow for detection and response to cases | 24 |
| | Appendix 2: Flow diagram for contact tracing, screening and monitoring | 25 |
| | Appendix 3: Collection of nasopharyngeal swab, oropharyngeal swab, mid-turbinate and anterior nares swab or nasopharyngeal aspirate..... | 26 |
| | Appendix 4: Procedures for submission of specimens for investigation..... | 28 |
| | Appendix 5: Contact tracing and contact line list | 30 |
| | Appendix 6: Contact monitoring tool | Error! Bookmark not defined. |
| | Appendix 7: Enhanced COVID-19 Notifiable Medical Conditions (NMC) Notification Form | 34 |
| | Appendix 8: Contact details (email address and telephone) of stakeholders involved in supporting outbreak response..... | 36 |

1 Introduction

On 31 December 2019, the World Health Organization (WHO) China country office reported a cluster of pneumonia cases in Wuhan, Hubei Province of China. On 7 January 2020, the causative pathogen was identified as a novel coronavirus (SARS-CoV-2)¹. Initially, most cases were epidemiologically linked to a seafood, poultry and live wildlife market (Huanan Seafood Wholesale Market) in Jianghan District of Hubei Province. However, the number of cases continued to increase rapidly, and evidence of person-to-person transmission mounted in travellers diagnosed with coronavirus disease (COVID-19) who had visited Wuhan².

The WHO International Health Regulations Emergency Committee declared that the outbreak of COVID-19 meets the criteria for a Public Health Emergency of International Concern (PHEIC) on 30 January 2020 ([https://www.who.int/news-room/detail/30-01-2020-statement-on-the-second-meeting-of-the-international-health-regulations-\(2005\)-emergency-committee-regarding-the-outbreak-of-novel-coronavirus-\(COVID-19\)](https://www.who.int/news-room/detail/30-01-2020-statement-on-the-second-meeting-of-the-international-health-regulations-(2005)-emergency-committee-regarding-the-outbreak-of-novel-coronavirus-(COVID-19))). By 11 March 2020, 114 countries had reported nearly 120,000 cases and WHO declared COVID-19 the first pandemic caused by a coronavirus. Daily WHO situation reports can be found at: <https://www.who.int/emergencies/diseases/novel-coronavirus-2019/situation-reports>.

Considering the pandemic declaration and the introduction of the virus in South Africa, South African authorities have compiled this guidance document to support surveillance, case finding, diagnosis, and public health response to cases under investigation.

THIS SITUATION IS RAPIDLY EVOLVING

BEFORE USING THIS DOCUMENT PLEASE CHECK FOR UPDATES ON THE NICD, NDOH and NIOH WEBSITES (www.nicd.ac.za and www.ndoh.gov.za and www.nioh.ac.za)

**OR CALL YOUR PROVINCIAL COMMUNICABLE DISEASE CO-ORDINATOR
(See Appendix 8 for contact details)**

2 Microbiology and epidemiology

Coronaviruses are enveloped, single-stranded positive-sense RNA viruses. The envelope of the coronavirus is covered with club-shaped glycoproteins which look like ‘crowns’, or ‘halos’ – hence the name ‘coronavirus’. Coronaviruses are responsible for the common cold, and usually cause self-limited upper respiratory tract infections. However, in 2003, a new coronavirus emerged leading to the SARS (severe acute respiratory syndrome) outbreak. In 2012, another novel coronavirus causing Middle East respiratory syndrome (MERS) was associated with transmission from camels. Both viruses had a range of clinical presentations from mild upper respiratory tract symptoms to severe acute respiratory

syndrome leading to sepsis, multi-organ failure and death in a sizeable proportion of cases. Severe cases were also associated with “super-spreader” events where a single case infected many individuals, often in healthcare settings.

Following the identification of a cluster of pneumonia cases in Wuhan, Hubei Province of China, Chinese authorities reported on 7 January 2020 that a novel coronavirus (SARS-CoV-2) was the cause of the newly named coronavirus disease 2019 (COVID-19). The gene sequences were deposited in Genbank, the NIH genetic sequence database, and in the Global Initiative on Sharing All Influenza Data (GISAID) portal. SARS-CoV-2 is thought to have originated in bats but the animal responsible for transmission to humans remains unknown.

While initial reports pointed to a possible zoonotic source, human-to-human transmission of SARS-CoV-2 was quickly confirmed. By 18 August 2020, 21 732 472 cases and 770 866 deaths had been reported globally. On 5 March 2020, South African Minister of Health Dr. Zwelini Mkhize announced the country’s first confirmed coronavirus (COVID-19) case. The patient, a 38-year-old male in KwaZulu-Natal Province, returned to South Africa on March 1 after traveling in Italy. He developed symptoms and visited a doctor on March 3 with fever, headache, malaise, sore throat and mild cough, and subsequently self-isolated. The NICD confirmed the positive COVID-19 result and initiated contact tracing while the patient and his doctor remained in self-isolation. Since that time the number of laboratory-confirmed cases in South Africa has increased to more than 589 886 and 11 982 laboratory-confirmed deaths have been reported. On March 15, 2020 after only 61 cases had been confirmed, the President of the Republic of South Africa declared a national state of disaster and immediately imposed restrictions on international travel, the size of public gatherings and school closures. The President subsequently announced a national lock-down beginning on March 27 to “flatten the epidemic curve” and allow for strengthening of healthcare capacity. The lockdown was extended to April 30, 2020. Since then restrictions are gradually being lifted.

Based on data from the first 425 confirmed cases in China, early estimates of transmission parameters are as follows: mean incubation period 5.2 days (95% confidence interval [CI], 4.1 to 7.0), mean serial interval 7.5 (95%CI: 5.3-19) days and basic reproductive number 2.2 (95%CI: 1.4-3.9)³ (meaning that on average each person spread the infection to two others).

3. Clinical presentation and management

Based on patients’ viral shedding patterns and on epidemiological modelling, patients appear to be infectious for 2-3 days prior to the onset of symptoms⁴⁻¹⁰. Truly asymptomatic COVID-19 patients have been described, but it is uncertain what proportion of infections they represent and what role they play in transmission of disease^{9,11}.

According to information from the Chinese Center for Disease Control and Prevention (China CDC) on the first 44 672 symptomatic cases detected in China¹². 81% developed mild disease, an estimated 14% developed severe disease (with hypoxaemia, marked tachypnoea and extensive lung infiltrates), while 5% became critically ill (with respiratory failure, septic shock and/or multiorgan dysfunction)¹². Fever is reported as the commonest symptom of COVID-19

(~90% of cases), but importantly this may only be present in a minority of patients on admission^{13, 14}. A cough is present in two-thirds of patients, but sputum production is only reported by one third of patients, as is dyspnoea. Myalgia, a sore throat, nausea, vomiting, and diarrhoea are less common (reported in <20% of cases)^{13, 14, 15}. Anosmia (loss of sense of smell) and dysgeusia (alteration of the sense of taste) have also emerged as relatively common, early, and moderately specific symptoms^{16, 17}. Abnormalities are visible on chest X-ray in at least 60% of hospitalised COVID-19 patients, with chest CT scans being more sensitive^{13,14,18}. COVID-19 may also have atypical manifestations, include large vessel strokes in young patients, unexplained abdominal pain, and a multisystem inflammatory syndrome in children¹⁹⁻²¹.

Globally, males have predominated both in terms of absolute case numbers, and in severe disease^{13,22,23}. Risk factors for severe disease include older age, cardiopulmonary comorbidities and diabetes mellitus. Very few cases which required hospitalisation have been reported among children under the age of 15 years (~1%). Given the strong effect of age on disease severity, the proportions of mild, severe, and critical cases in any country will be partially dependent on that country's population age structure. There is a paucity of data on associations between patients with HIV or TB and COVID-19; however, early data from the Western Cape Province indicate that HIV-infection may be associated with a 2 to 3-fold increased risk in COVID-19 hospitalisation and death²⁴.

The majority of COVID-19 cases recover fully although this may take several weeks. In a minority of cases, COVID-19 has been associated with rapid progression to acute respiratory distress syndrome (ARDS), multiple organ failure and sometimes death. Estimates of the case fatality ratio have ranged between 0.7-7% internationally, and are partially determined by the particular population's age distribution, the pandemic's burden on the healthcare system at the time, and the extent to which mild or asymptomatic cases are diagnosed^{13,25}. There is currently no specific treatment for disease caused by SARS-CoV-2 infection. Clinical management guidelines from the NDOH and NICD can be found [here](#)²⁶.

4. Case definitions for COVID-19

Who should be tested for SARS-CoV-2?

Suspected COVID-19 case definition: Any person presenting with an acute (≤ 10 days) respiratory tract infection or other clinical illness compatible with COVID-19, or an asymptomatic person who is a close contact^a of a confirmed^b case

- Symptoms include ANY of the following respiratory symptoms: cough, sore throat, shortness of breath, anosmia (loss of sense of smell) or dysgeusia (alteration of the sense of taste), with or without other symptoms (which may include fever, weakness, myalgia, or diarrhoea)
- Note: Asymptomatic close contacts should not be routinely tested despite meeting the suspected case definition. However, testing may be indicated in certain circumstances (e.g. institutions such as care homes)

^a**A close contact of a person with laboratory-confirmed COVID-19 is:** A person having had face-to-face contact (≤ 1 metre) or been in a closed space with a confirmed case for at least 15 minutes. This includes, amongst others, all persons living in the same household as a case, and people working closely in the same environment as a case. Healthcare workers or other people providing direct care for a case, while not wearing recommended personal protective equipment or PPE (e.g., gowns, gloves, N95 respirator, eye protection). A contact in an aircraft sitting within two seats (in any direction) of the case, travel companions or persons providing care, and crew members serving in the section of the aircraft where the case was seated.

^b**A confirmed case of COVID-19 is:** A person with laboratory confirmation of SARS-CoV-2 infection (using an RT-PCR assay), irrespective of clinical signs and symptoms. Symptomatic cases are considered infectious from 2 days before symptom onset up to 10 days after symptom onset. Guidelines are also available for symptom monitoring and management of essential workers for COVID-19 related infection [here](#)²⁷. Healthcare workers are advised to consult these guidelines.

5. Clinical management of COVID-19

Consult the 'Clinical management of suspected or confirmed COVID-19 disease, Version 4 (18th May 2020) or updated version on the NICD website at <https://www.nicd.ac.za/diseases-a-z-index/covid-19/covid-19-guidelines/clinical-management-of-suspected-or-confirmed-covid-19-disease/> for detailed guidelines on clinical management of COVID-19²⁶.

6. Infection control

SARS-CoV-2 is transmitted from person-to-person mainly by droplet transmission, but airborne and direct transmission (e.g. from contaminated surfaces, or touching persons who have infectious secretions). The exact contribution of each transmission modality is not fully understood. It appears that viral shedding is greatest during the early phase of the illness, and some transmission may occur from persons who are asymptomatic or pre-symptomatic. Therefore, infection prevention and control measures should be directed towards droplet, airborne and direct transmission.

Healthcare workers are advised to refer to current guidelines on infection prevention and control (IPC) [here](#)²⁸.

Patients with suspected COVID-19 cared for in the home environment

Patients with suspected or confirmed COVID-19 who have mild disease, may be isolated/managed at home if they are able to safely self-isolate. Advice to minimise exposure of household contacts is available²⁶.

7. Laboratory diagnosis

Only patients meeting the criteria for a suspected case of COVID-19 or essential workers eligible for testing as per guidelines, should be tested. Given the global shortage of test kits and the rapidly evolving epidemic in South Africa,

guidelines for testing may change over time and are likely to become more targeted, Provincial or National guidelines should be consulted. Rapid collection, transport and testing of appropriate specimens from these patients is a priority. Patients should be managed as potentially infected when the clinical and epidemiological data strongly suggest SARS-CoV-2 infection.

Clinical specimens should be collected as soon as possible after onset of symptoms, ideally within 7 days. If a patient presents ≥ 7 days from symptom onset and is still symptomatic, respiratory samples should be collected.

What investigations should be done?

- From the moment that COVID-19 is considered as a diagnostic possibility, persons under investigation should be isolated, and infection control measures should be implemented.
- Specimens should be collected and transported urgently (same day as collection) for SARS-CoV-2 testing.
- Patients with severe illness should also undergo routinely available laboratory tests as clinically indicated according to the clinical guidance above and local management guidelines for community-acquired pneumonia to determine the presence of other potential primary aetiologies of pneumonia (e.g. *Streptococcus pneumoniae*, *Haemophilus influenzae*, *Mycoplasma pneumoniae*, *Legionella pneumophila*, *Mycobacterium tuberculosis* and respiratory viruses including influenza, and respiratory syncytial virus (RSV)).
- As the role of co-infections is not yet clearly understood, identification of a conventional respiratory pathogen does not rule out SARS-CoV-2 infection.

Specimen collection and transport

- Infection prevention and control guidelines, including adequate PPE, must be followed during specimen collection, and all specimens handled as potentially infectious.
- Recommended swab types include flocced (polyester/nylon) or spun fibre (polyester/rayon) swabs with plastic or aluminium shafts. Calcium alginate swabs or swabs with wooden shafts are not recommended, as they may contain substances that inactivate some viruses and inhibit PCR testing.
- Respiratory viruses are best isolated from material that contains infected cells and secretions. Therefore, swabs should aim to brush cells and secretions off the mucous membranes of the upper respiratory tract. Good specimen quality (i.e. containing sufficient cells and secretions) and appropriate packaging and transport (i.e., to keep virus viable/detectable) are essential.
- **Lower respiratory tract samples are the preferred specimen type because the lower respiratory tract is the primary site of infection** and they are likely to contain the highest viral loads (based on experience with MERS-CoV) and therefore have a better yield. For severe cases, collection of both lower and upper airway specimens for SARS-CoV-2 testing is recommended.

- Upper respiratory tract specimens - A single nasopharyngeal swab is the preferred sample type. When not possible, a single nasal mid-turbinate swab, nasal or oropharyngeal swab may be collected (See appendix 5 on how to collect samples).
- Transport and store swabs in universal/viral transport medium (UTM) or sterile saline, between 2-8°C. If UTM is not available, use dry swabs in a sterile tube. Dry swabs can be sent at ambient temperature but must reach the laboratory within 2 days.
- Lower respiratory tract specimens (hospitalised/severe cases) – sputum (expectorated only – **do NOT induce**), bronchoalveolar lavage, or endotracheal aspirate should be submitted in clean universal containers. Does not require UTM.
- Appendix 6 describes detailed procedures for submission of specimens (local and international) to NHLS/Private labs for SARS-CoV-2 testing.
- **A completed NHLS or private laboratory specimen submission form must be submitted to the laboratory together with specimens for SARS-CoV-2 testing.** Mandatory information to be provided on lab request form includes:
 - Facility name
 - Ward name
 - Patient information: a) Surname and name, b) Sex, c) Date of birth, d) Address, e) Mobile telephone number, f) Alternative telephone number, and g) ID number (or passport number)
 - Specimen type
 - Collection date and time
 - Test required: SARS-CoV-2 PCR
 - Healthcare worker name and contact details

Table 1. Type of specimens that can be collected for SARS-CoV-2/COVID-19 diagnostics and the transport requirements of those specimens

| Specimen type | Collection materials | Storage and transportation | Dangerous goods shipping category | Comment |
|--|---|--|-----------------------------------|--|
| FOR SYMPTOMATIC PATIENTS: | | | | |
| Sputum* | Deep cough sputum in sterile leak proof container | Refrigerate and ship at 2-8 °C up to 48 hrs, if >48 hrs freeze at -70°C and ship on dry ice | Biological substance, Category B | The preferred sample but need to ensure the material is from the lower respiratory tract |
| Bronchoalveolar lavage* | 2-3 ml in sterile leak proof container | Refrigerate and ship at 2-8 °C up to 48 hrs, if >48 hrs freeze at -70°C and ship on dry ice | Biological substance, Category B | There may be some dilution of virus but still a worthwhile specimen |
| (Endo)tracheal or nasopharyngeal aspirate* | 2-3 ml in sterile leak proof container | Refrigerate and ship at 2-8 °C up to 48 hrs, if >48 hrs freeze at -70°C and ship on dry ice | Biological substance, Category B | |
| Nasopharyngeal, nasal mid-turbinate, nasal or oropharyngeal swab | Dacron or nylon flocked swab in Universal Transport Medium (UTM), or in saline/dry if UTM not available, in a | Refrigerate at 2-8 °C up to 5 days, if >5 days freeze at -70°C and ship on dry ice Dry swabs can be transported at ambient temperature but must reach the lab within 2 days | Biological substance, Category B | If collecting both, nasopharyngeal and oropharyngeal swabs should be placed in the same UTM tube to increase virus detection |

| | | | | |
|------------------------------------|-------------------------------|---|--|--|
| | sterile leak proof container | | | |
| Lung tissue from biopsy or autopsy | Sterile container with saline | Refrigerate and ship at 2-8 °C up to 24 hrs, if >24 hrs freeze at -70°C and ship on dry ice | | |

* Aerosol-generating procedures may pose an infection risk for healthcare workers.

Healthcare workers are advised to consult the Centers for Disease Control and Prevention document for **specific guidance for the collection and submission of post-mortem specimens from deceased known or suspected COVID-19 cases available [here](#)**²⁹.

Laboratory diagnostic assays and interpretation of results

Routine confirmation of cases of COVID-19 is based on amplification and detection of unique SARS-CoV-2 viral nucleic acid sequences by real-time reverse-transcription polymerase chain reaction (rRT-PCR). Testing for SARS-CoV-2 is performed using any one of several in-house and commercial PCR assays to test for the presence of SARS-CoV-2 RNA^{30,31}. Testing for SARS-CoV-2 must be performed in appropriately equipped laboratories by staff trained in the relevant technical and safety procedures. Initial processing of specimens (before inactivation) should be done in a biological safety cabinet. Molecular testing should be conducted in a BSL-2 laboratory. Viral culture and isolation should only be performed by properly trained and competent personnel in a BSL-3 laboratory. Appropriate PPE must be worn by all laboratory personnel handling SARS-CoV-2 specimens.

A negative result does not rule out the possibility of a SARS-CoV-2 infection. Several factors could lead to a false negative result including:

- Poor specimen quality or inappropriate handling during shipment or storage;
- The specimen was collected late or very early in the illness;
- Technical reasons inherent in the test, e.g virus mutation or PCR inhibition.

If a high clinical suspicion for COVID-19 persists despite an initial negative test, repeat testing should be considered in consultation with an infectious diseases expert, particularly in hospitalised patients for whom management might be significantly altered. However, it is equally important to maintain a broad differential diagnosis and to always consider alternative diagnoses²⁶.

A single positive PCR test is sufficient proof of COVID-19 infection. Repeat “confirmatory” PCR testing on asymptomatic patients who test positive is not indicated, as PCR-based tests have excellent specificity, and asymptomatic and pre-symptomatic COVID-19 patients are now well described²⁶.

Repeat testing is not indicated to de-isolate a patient:

Patients with COVID-19 infection continue to shed SARS-CoV-2 from their upper airways for approximately 7-12 days or longer^{25,32,33,34}. Duration of viral shedding may be longer in patients with severe disease, but considerable variation is noted in all groups. Patients can remain PCR positive even after they are no longer infectious, either because levels of viral shedding may have declined to a level below the infectious threshold and/or non-viable virus may be shed. **It is not necessary to repeat PCR testing in order to de-isolate a patient.** Patients can be de-isolated 10 days after the onset of their symptoms (in mild cases), 10 days after achieving clinical stability (in severe cases), or 10 days after the positive test (in asymptomatic cases). Refer to Clinical management of suspected or confirmed COVID-19 disease²⁶.

Currently, we do not recommend using antibody-based (serological) tests for the diagnosis of acute COVID-19.

8. Public health response

The detection of a case of COVID-19 constitutes a public health emergency and a risk to the safety of the patient, their contacts including healthcare workers, and more broadly, the well-being of the South African community. Even at the time the decision is made to test a patient for COVID-19, consideration must be made of the public health response. Interventions to prevent onward transmission through human-to-human spread are essential to control the COVID-19 epidemic. Case identification, isolation, testing and management, contact tracing and quarantine are critical components of the strategy to reduce transmission and control the epidemic³⁵.

The South African National Department of Health, the NICD and provincial health departments have structures for responding to outbreaks of communicable diseases, and these have been activated to respond to COVID-19.

Response to a suspected case

Patients meeting the definition for a suspected case of COVID-19 should be sampled and isolated, they do not need to be notified. Contact information including cell phone number and SA National ID number (or Passport number for non-South Africans) should be recorded on the specimen submission form.

Public Health response to a confirmed case

- Upon receipt of a positive laboratory result, the clinician should notify the case using the national Notifiable Medical Conditions (NMC) system. Case notification (for all confirmed cases) COVID-19 is classified as a Category 1 notifiable medical condition (NMC). Notification of probable and confirmed cases should be made immediately, using the NMC web portal, mobile app (preferred methods), or NMC paper-based reporting form. The COVID-19 NMC case notification form https://www.nicd.ac.za/wp-content/uploads/2020/06/COVID-19_Case_Notification_Form_05June2020.pdf and an SOP (https://www.nicd.ac.za/wp-content/uploads/2020/05/NMC_COVID-19-Notification-SOP_7May2020.pdf).

The COVID-19 case notification form was developed to collect additional data elements previously recorded in the “Patient under Investigation” form which has now been discontinued.

- The clinician should evaluate the patient at the time of specimen collection and subsequently to establish if admission is required. Clinical criteria for management of persons at home are found in clinical guidelines²⁶.
- Identification of close contacts should commence as soon as a positive result is obtained.
 - Employers may support contact tracing in the work environment,
 - District public health officials will conduct contact tracing to support household contacts and other contacts such as schools or institutions.
- A definition of a close contact is shown in the text box in section 4.
 - Any person who has had close contact with a confirmed case while the confirmed case was ill or in the 2 days preceding illness onset should self-quarantine (at home or in a quarantine facility) and be carefully monitored for the appearance of respiratory symptoms. (Quarantine is the physical separation and activity restriction of a **well** person who has been exposed to a contagious disease.)

Contact tracing

International guidelines suggest that contact tracing is resource intensive and needs to be implemented in accordance with local resources and phase of epidemic³⁵. Different parts of the country may be in different phases at the same time. Local guidelines should be considered.

For contact tracing to be effective, there must be capacity to test and result suspected cases timeously. Modelling data suggest that unless contact tracing is initiated within 72 hours of symptom onset it will have limited impact in preventing secondary and tertiary cases³⁶. For this reason, every effort should be made to initiate contact tracing within 24 hours of notification of a positive test.

- Contact tracing has been decentralised to provincial or district level.
- Some provinces are implementing electronic tools and information technology (such as COVID Connect, or the DHIS contact tracing tool). These applications may assist contact tracing teams to collect data on contacts or the software may share results with cases and invite them to submit names of contacts. These software systems should be integrated into current workflows that are used by contact tracing teams.
- WHO guidelines emphasise that “contact tracing begins with engaging communities about COVID-19 and how to protect individuals and communities. Communication about contact tracing should emphasise solidarity, reciprocity and the common good. By participating in contact tracing, communities will contribute to controlling local spread of COVID-19 and protecting vulnerable people”³⁵. Confidentiality should be protected and concerns regarding data collection and privacy addressed.
- A flow diagram for contact tracing is in Appendix 2. A contact line list (Example shown in Appendix 5) should be completed for each person under investigation at time the positive laboratory result is received by the facility infection control focal point or attending clinician. The district or provincial outbreak response team must ensure that the contact line list is completed.

- Details of close contacts from 2 days prior to symptom onset will be collected on the contact line list.
- If laboratory testing confirms SARS-CoV-2 infection, the district/provincial outbreak response team will be requested to use the contact line list to call each contact to complete the contact demographic section on the contact monitoring form.
- Close contacts will be asked to self-quarantine themselves at home for 10 days since last exposure to the confirmed COVID-19 case.
- Close contacts will self-monitor for 10 days following their last exposure to the confirmed case using a symptom monitoring tool (Example shown in Appendix 6). In certain circumstances, the district outbreak team may choose to telephonically monitor a close contact and if at any point during the monitoring period the contact becomes unreachable for more than 24 hours, the district/provincial team may do a home visit.
- If a close contact develops symptoms during quarantine, the individual should be tested for COVID-19 according to provincial or national guidelines. Persons should be tested according to local referral pathways for testing and treatment in their district. Note that testing guidance is continually changing in response to outbreak stage, burden of cases and laboratory capacity.
- Close contacts who are ill but do not require hospitalisation for medical reasons may be cared for and isolated in their home. Clinical criteria for admission to a health care facility are found in the Guidelines for Clinical management of suspected or confirmed COVID-19. Resources for persons who are contacts may be found on the NICD website^{26,37}.
- Although asymptomatic close contacts are classified as suspected cases, they should not routinely be tested but should remain in quarantine under close monitoring for 10 days. However, under certain circumstances (e.g. during outbreaks in healthcare facilities or care homes) testing of asymptomatic contacts may be indicated, as described in the Outbreak investigation guidelines³⁸ available [here](#). Specific guidelines are available for Essential workers including healthcare workers are available [here](#)²⁷.
- The monitoring phase ends 10 days after the contact's last exposure to the confirmed case or if the contact develops COVID-19.
- If confirmed cases are asymptomatic, contacts should still be managed in the same way as for a symptomatic case (this is because asymptomatic individuals may transmit COVID-19).
- Close contacts under monitoring should be advised to:
 - Remain at home
 - Self-isolate in a room separate from other members of the household
 - Avoid unnecessary social contact
 - Avoid travel
 - Remain reachable for monitoring
- Currently, should a contact develop symptoms, arrangements should be made for a specimen to be collected in line with local referral pathways. The laboratory/facility must be notified before or at arrival that the

patient is a contact of a confirmed COVID-19 case in order for the healthcare facility to use appropriate infection prevention and control (IPC) measures.

Casual contacts (i.e. known contacts who do not meet the close contact case definition) should be informed of their potential exposure by the case-patient and encouraged to seek care if they develop symptoms. However, casual contacts are not required to quarantine and do not require daily symptom monitoring.

A database of contact tracing should be maintained. Descriptive analysis and relevant performance indicators should be compiled regularly and communicated upwards (to province or national) in accordance with agreed systems. Feedback should also be given to the contact tracing teams. Systems should be implemented to maintain privacy.

The National Indicator Data set (NIDS) for COVID-19 contact tracing includes: proportion of close contacts followed, proportion of close contacts lost to follow-up, proportion of close contacts who become suspect cases, proportion of close contacts who become known cases and proportion of new cases who are known contacts³⁵.

Healthcare workers with occupational exposure

- Lists of healthcare workers with occupation exposure should be compiled by the health facility
- Symptom monitoring and management is based on level of risk, considering type of exposure and PPE use at time of exposure.

Healthcare workers must refer to: **Guidelines for symptom monitoring and management of essential workers for COVID-19 related infection²⁷**.

Quarantine

Quarantine entails separating **asymptomatic** individuals potentially exposed to a disease from non-exposed individuals. Quarantine is to be distinguished from isolation, which is the act of separating a **sick** individual with a contagious disease from healthy individuals without that contagious disease. Quarantine procedures can be effective in limiting and slowing the introduction of a novel pathogen into a population but may entail the use of considerable resources and may infringe on the rights of members of society. Quarantine may be voluntary (e.g. asking contacts of infectious cases to stay at home for 10 days) or involuntary (i.e. using legal powers to enforce quarantine against a person's will). Quarantine may take place in the home (e.g. asking contacts of infectious cases to stay at home for 10 days) or in a designated facility. Quarantine may be applied at the individual level or to a group or community of exposed persons. Asymptomatic contacts will be voluntarily quarantined at home³⁹.

9. Recording and Reporting

Recording and reporting of COVID-19 cases is essential to track the size and severity of the epidemic, the care received by patients in and out of hospital, risk factors for mortality and to identify areas for improvement in current and future outbreaks.

Different tools will need to be completed. These are summarised in “Clinical management of suspected or confirmed COVID-19 disease”²⁶.

Table showing tools available for COVID-19 recording and reporting

| Tool | When to complete | Comments |
|--|---|--|
| Contact line list | To be completed for all individuals suspected of COVID 19 disease and having a specimen taken | This needs to be completed for all patients from whom COVID-19 samples are collected. |
| Laboratory request form | For all COVID-19 specimens | Always include patient’s ID/passport number and contact details |
| Clinical platform for hospitalised patients | To be completed for all confirmed inpatients daily (until discharge). | This form will document the presence of comorbidities, clinical progression, treatment and outcomes. |
| Home assessment forms ¹ | To be completed at de-isolation, for all patients being cared for at home | This form will document patient progress and outcomes |
| Notifiable medical condition (NMC) case notification | To be completed for all laboratory-confirmed COVID-19 cases | No longer required to notify suspected cases, only confirmed cases. |

COVID-19 definition of RECOVERED

Surveillance definition:

For epidemiological/ surveillance purposes and to standardize reporting, the following simple definition of **recovered** should be used:

A person with probable/confirmed COVID-19 is known to be alive and 14 days have elapsed since diagnosis (for asymptomatic), onset of symptoms (for mild cases) or clinical stability/ supplementary oxygen stopped (for moderate-severe cases in hospital).

Note – For practical purposes, this surveillance definition does not specify resolution of fever and improvement of symptoms at the time of de-isolation or return to work. Repeat PCR testing is not required as a surveillance criterion for recovery.

For purposes of comparison:

Clinical definition:

“Recovered” is not specifically mentioned or defined in the Guideline for clinical management of suspected or confirmed COVID-19 disease (version 4).

However, the following criteria are specified for de-isolation of a person with RT-PCR-confirmed COVID-19:

1. Asymptomatic patients: 10 days after initial positive test
2. 10 days after the onset of their symptoms for cases of mild disease (this is defined as SpO₂ ≥95% and respiratory rate <25 and heart rate <120 and temperature 36-39°C and no change in mental status)
3. 10 days after achieving clinical stability (e.g. after supplemental oxygen was discontinued) for cases with moderate-severe disease

4. Patients who are still symptomatic at the end of their isolation period can be de-isolated provided that their fever has resolved and their symptoms have shown improvement.
5. It is not necessary to repeat PCR testing in order to de-isolate a patient.

Occupational health definition:

Similar criteria are applied to employees who are confirmed as COVID-19 cases before they can return to work. This is outlined in the DOH guideline for symptom monitoring and management of essential workers for COVID-19 (version 1).

Employees can return to work:

1. 10 days after symptom onset for cases of mild disease
2. 10 days after clinical stability (e.g. after oxygen stopped) for cases of severe disease

Note: PCR testing is not required for return to work (exception: if a person remains asymptomatic in quarantine after a high-risk exposure to a confirmed COVID-19 case, a PCR test should be done when assessing the employee for early return to work on day 8 post-exposure).

Management of the deceased

Healthcare workers should refer to: COVID-19 Disease: Infection Prevention and Control guidelines²⁸ for guidance on handling of mortal remains for healthcare workers and families and infection prevention and control measures during autopsy.

10. References

1. World Health Organization (WHO), <https://www.who.int/emergencies/diseases/novel-coronavirus-2019>
2. Centers for Disease Control and Prevention (CDC), <https://www.cdc.gov/media/releases/2020/p0130-coronavirus-spread.html>
3. Li et al. Early Transmission Dynamics in Wuhan, China, of Novel Coronavirus-Infected Pneumonia, *N Engl J Med*, 2020.
4. Du Z, Xu X, Wu Y, Wang L, Cowling BJ, Meyers LA. Serial Interval of COVID-19 among Publicly Reported Confirmed Cases. *Emerg Infect Dis*. 2020;26(6).
5. Yu P, Zhu J, Zhang Z, Han Y, Huang L. A familial cluster of infection associated with the 2019 novel coronavirus indicating potential person-to-person transmission during the incubation period. *J Infect Dis*. 2020.
6. Tindale L, Coombe M, Stockdale JE, Garlock E, Lau WYV, Saraswat M, et al. Transmission interval estimates suggest pre-symptomatic spread of COVID-19. *medRxiv*. 2020:2020.03.03.20029983.
7. Nishiura H, Linton NM, Akhmetzhanov AR. Serial interval of novel coronavirus (COVID-19) infections. *Int J Infect Dis*. 2020;93:284-6.
8. Nishiura H, Kobayashi T, Suzuki A, Jung SM, Hayashi K, Kinoshita R, et al. Estimation of the asymptomatic ratio of novel coronavirus infections (COVID-19). *Int J Infect Dis*. 2020.
9. Arons MM, Hatfield KM, Reddy SC, Kimball A, James A, Jacobs JR, et al. Presymptomatic SARS-CoV-2 Infections and Transmission in a Skilled Nursing Facility. *New England Journal of Medicine*. 2020.
10. Gandhi M, Yokoe DS, Havlir DV. Asymptomatic Transmission, the Achilles' Heel of Current Strategies to Control Covid-19. *New England Journal of Medicine*. 2020.
11. Mizumoto K, Kagaya K, Zarebski A, Chowell G. Estimating the asymptomatic proportion of coronavirus disease 2019 (COVID-19) cases on board the Diamond Princess cruise ship, Yokohama, Japan, 2020. *Euro Surveill*. 2020;25(10)
12. Wu Z, McGoogan JM. Characteristics of and Important Lessons From the Coronavirus Disease 2019 (COVID-19) Outbreak in China: Summary of a Report of 72314 Cases From the Chinese Center for Disease Control and Prevention. *JAMA*. 2020.
13. Guan WJ, Ni ZY, Hu Y, Liang WH, Ou CQ, He JX, et al. Clinical Characteristics of Coronavirus Disease 2019 in China. *N Engl J Med*. 2020.
14. Goyal P, Choi JJ, Pinheiro LC, Schenck EJ, Chen R, Jabri A, et al. Clinical Characteristics of Covid-19 in New York City. *N Engl J Med*. 2020.
15. Wang D, Hu B, Hu C, Zhu F, Liu X, Zhang J, et al. Clinical Characteristics of 138 Hospitalized Patients With 2019 Novel Coronavirus-Infected Pneumonia in Wuhan, China. *JAMA*. 2020.
16. Giacomelli A, Pezzati L, Conti F, Bernacchia D, Siano M, Oreni L, et al. Self-reported olfactory and taste disorders in SARS-CoV-2 patients: a cross-sectional study. *Clin Infect Dis*. 2020.
17. Yan CH, Faraji F, Prajapati DP, Boone CE, DeConde AS. Association of chemosensory dysfunction and Covid-19 in patients presenting with influenza-like symptoms. *Int Forum Allergy Rhinol*. 2020.
18. Wong HYF, Lam HYS, Fong AH-T, Leung ST, Chin TW-Y, Lo CSY, et al. Frequency and Distribution of Chest Radiographic Findings in COVID-19 Positive Patients. *Radiology*. 0(0):201160
19. Oxley TJ, Mocco J, Majidi S, Kellner CP, Shoirah H, Singh IP, et al. Large-Vessel Stroke as a Presenting Feature of Covid-19 in the Young. *N Engl J Med*. 2020.

20. Galvan Casas C, Catala A, Carretero Hernandez G, Rodriguez-Jimenez P, Fernandez Nieto D, Rodriguez-Villa Lario A, et al. Classification of the cutaneous manifestations of COVID-19: a rapid prospective nationwide consensus study in Spain with 375 cases. *Br J Dermatol*. 2020.
21. Riphagen S, Gomez X, Gonzalez-Martinez C, Wilkinson N, Theocharis P. Hyperinflammatory shock in children during COVID-19 pandemic. *Lancet*. 2020.
22. Onder G, Rezza G, Brusaferro S. Case-Fatality Rate and Characteristics of Patients Dying in Relation to COVID-19 in Italy. *JAMA*. 2020.
23. Chen T, Wu D, Chen H, Yan W, Yang D, Chen G, et al. Clinical characteristics of 113 deceased patients with coronavirus disease 2019: retrospective study. *BMJ*. 2020;368:m1091.
24. National Institute for Communicable Diseases. COVID-19 Special Public Health Surveillance Bulletin. Volume 18. Supplementary Issue 2, 22 June 2020. Available at: <https://www.nicd.ac.za/wp-content/uploads/2020/06/COVID-19-Special-Public-Health-Surveillance-Bulletin-22-June-2020.pdf>
25. World Health Organization. Report of the WHO-China Joint Mission on Coronavirus Disease 2019 (COVID-19)2020. Available at: <https://www.who.int/docs/defaultsource/coronaviruse/who-china-joint-mission-on-covid-19-final-report.pdf>
26. National Department of Health. Clinical management of suspected or confirmed COVID-19 - 20 May 2020. Available at: <http://www.health.gov.za/index.php/component/phocadownload/category/628>
27. National Department of Health. Guidelines for symptom monitoring and management of essential workers for COVID-19 related infection. Available at: <https://www.nicd.ac.za/wp-content/uploads/2020/04/Guidance-for-symptom-monitoring-and-management-of-essential-staff-with-COVID-19-related-illness-final-2.pdf>
28. National Department of Health. COVID-19 Disease: Infection Prevention and Control Guidelines. Available at: <https://www.nicd.ac.za/wp-content/uploads/2020/05/ipc-guidelines-covid-19-version-2-21-may-2020.pdf>
29. Centers for Disease Control and Prevention. Collection and Submission of Postmortem Specimens from Deceased Persons with Known or Suspected COVID-19. Available at: <https://www.cdc.gov/coronavirus/2019-ncov/hcp/guidance-postmortem-specimens.html>
30. World Health Organization. Laboratory testing for 2019 novel coronavirus (COVID-19) in suspected human cases Interim guidance 14 January 2020 [cited 30 January 2020] https://www.who.int/docs/default-source/coronaviruse/20200114-interim-laboratory-guidance-version.pdf?sfvrsn=6967c39b_4&download=true
31. Corman, V. et al., Detection of 2019 novel coronavirus (COVID-19) by real-time RT-PCR. *Euro Surveill*. 2020;25(3):pii=2000045. <https://doi.org/10.2807/1560-7917.ES.2020.25.3.2000045>
32. Liu Y, Yan L-M, Wan L, Xiang T-X, Le A, Liu J-M, et al. Viral dynamics in mild and severe cases of COVID-19. *Lancet Infect Dis* [Internet]. 2020. Available at: [https://www.thelancet.com/journals/laninf/article/PIIS1473-3099\(20\)30232-2/fulltext](https://www.thelancet.com/journals/laninf/article/PIIS1473-3099(20)30232-2/fulltext)
33. Young BE, Ong SWX, Kalimuddin S, Low JG, Tan SY, Loh J, et al. Epidemiologic Features and Clinical Course of Patients Infected With SARS-CoV-2 in Singapore. *JAMA*. 2020.
34. Zhou F, Yu T, Du R, Fan G, Liu Y, Liu Z, et al. Clinical course and risk factors for mortality of adult inpatients with COVID-19 in Wuhan, China: a retrospective cohort study. *Lancet*. 2020.
35. WHO Contact tracing in the context of COVID-19, Interim guidance, 10 May 2020. Available at: file:///C:/Users/irmal/Downloads/WHO-2019-nCoV-Contact_Tracing-2020.1-eng.pdf

36. Ferretti L, Wymant C, Kendall M, Zhao L, Nurtay A, Abeler-Dörner L, Parker M, Bonsall D, Fraser C. Quantifying SARS-CoV-2 Transmission Suggests Epidemic Control With Digital Contact Tracing. *Science*. 2020 May 8;368(6491):eabb6936. doi: 10.1126/science.abb6936
37. National Institute for Communicable Diseases. What to do if i am a close contact of a person with confirmed disease and am asked to home quarantine? Available at: <https://www.nicd.ac.za/diseases-a-z-index/covid-19/advice-for-the-public/what-to-do-if-i-am-a-close-contact-of-a-person-with-confirmed-disease-and-am-asked-to-home-quarantine/>
38. National Department of Health. COVID-19 Outbreak investigation manual. A practical guide and manual for healthcare facilities (including care homes for the elderly, infirm or mental health care users). Available at: https://www.nicd.ac.za/wp-content/uploads/2020/06/COVID-Outbreak-Investigation-Guidelines_Finaldraft_20200624.pdf
39. National Department of Health. Guidelines for quarantine and isolation in relation to covid-19 exposure and infection. Available at: <https://www.nicd.ac.za/wp-content/uploads/2020/05/Guidelines-for-Quarantine-and-Isolation-in-relation-to-COVID-19.pdf>

11. Additional Resources

- NICD website on COVID-19: <http://www.nicd.ac.za/diseases-a-z-index/covid-19/>
- Daily WHO situation update: <https://www.who.int/emergencies/diseases/novel-coronavirus-2019/situation-reports/>
- WHO Coronavirus Information Page: <https://www.who.int/emergencies/diseases/novel-coronavirus-2019>
- Centers for Disease Control and Prevention (CDC), <https://www.cdc.gov/coronavirus/COVID-19/index.html>
- National Department of Health: <http://www.health.gov.za/>
- National Institute of Occupational Health: <http://www.nioh.ac.za/>
- National Health Laboratory Service: <https://www.nhls.ac.za/>
- WHO guidelines to minimise exposure of household contact: [https://www.who.int/publications-detail/home-care-for-patients-with-suspected-novel-coronavirus-\(ncov\)-infection-presenting-with-mild-symptoms-and-management-of-contacts](https://www.who.int/publications-detail/home-care-for-patients-with-suspected-novel-coronavirus-(ncov)-infection-presenting-with-mild-symptoms-and-management-of-contacts)

12. Appendices

Appendix 1: Process flow for detection and response to cases

DETECTION AND REPORTING OF PERSON UNDER INVESTIGATION FOR COVID-19

- For any person meeting the criteria for a suspected case of COVID-19, isolate the patient in a suitable room/ unit for assessment and apply IPC measures
- Collect specimen and complete specimen submission form required by laboratory. The patient's SA National ID number (or passport number for foreign nationals) and cell phone number must be recorded on the specimen submission form
- Guidelines for the collection and submission of specimens are available on the NICD website: (see quick reference for healthcare workers <https://www.nicd.ac.za/wp-content/uploads/2020/09/COVID-19-Quick-reference-v15-19.08.2020.pdf>) or Appendices 3 and 4 of this document.

**Contacts and details:
Consultant on call for
Infectious Diseases
0800 029 999**

MEDICAL MANAGEMENT

- For all cases irrespective of symptom severity, isolate the patient and apply infection precautions in accordance with site-specific standard operating procedures. COVID-19 cases with mild illness should self-isolate at home. If self-isolation is not possible in the home, assisted isolation should be provided.

TRANSPORT AND/OR REFERRAL OF PERSON UNDER INVESTIGATION FOR COVID-19 TO HOSPITAL

- If facility is able to provide required clinical care for patient in isolation, referral or transfer is not indicated. If facility cannot offer required care, transfer or referral should be discussed by calling the receiving hospital.
- Transfer of patients from port of entry to healthcare facilities to be discussed with EMS to facilitate transport arrangements. Contact numbers are in Appendix 8.

Laboratory testing
excludes SARS-CoV-2

- If index of suspicion high for COVID-19, repeat testing may be considered in hospitalised patient. Keep patient in isolation.
- Else assume COVID-19 negative.
- Encourage the patient to remain isolated until symptoms resolve.

Laboratory testing
confirms SARS-CoV-2

MULTI-DISCIPLINARY PUBLIC HEALTH RESPONSE

- Ensure COVID-19 case-patient receives appropriate care:
 - Mild illness – self-isolate at home
 - Severe illness – transport to hospital for supportive care
- Facility infection control focal point or ordering clinician should immediately notify the case via NMC and complete the contact line list
- District/Provincial outreach teams to perform contact tracing as described in Appendix 5
- Collate information and share reports with key stakeholders
- Handling of mortal remains of a **confirmed or probable** case must be in accordance with guidelines²⁸. <https://www.nicd.ac.za/wp-content/uploads/2020/05/ipc-guidelines-covid-19-version-2-21-may-2020.pdf>
- Communicate efficiently and transparently with the media (press release/briefs)
- Complete reports and share with NDoH/NICD

Appendix 2: Flow diagram for contact tracing, screening and monitoring

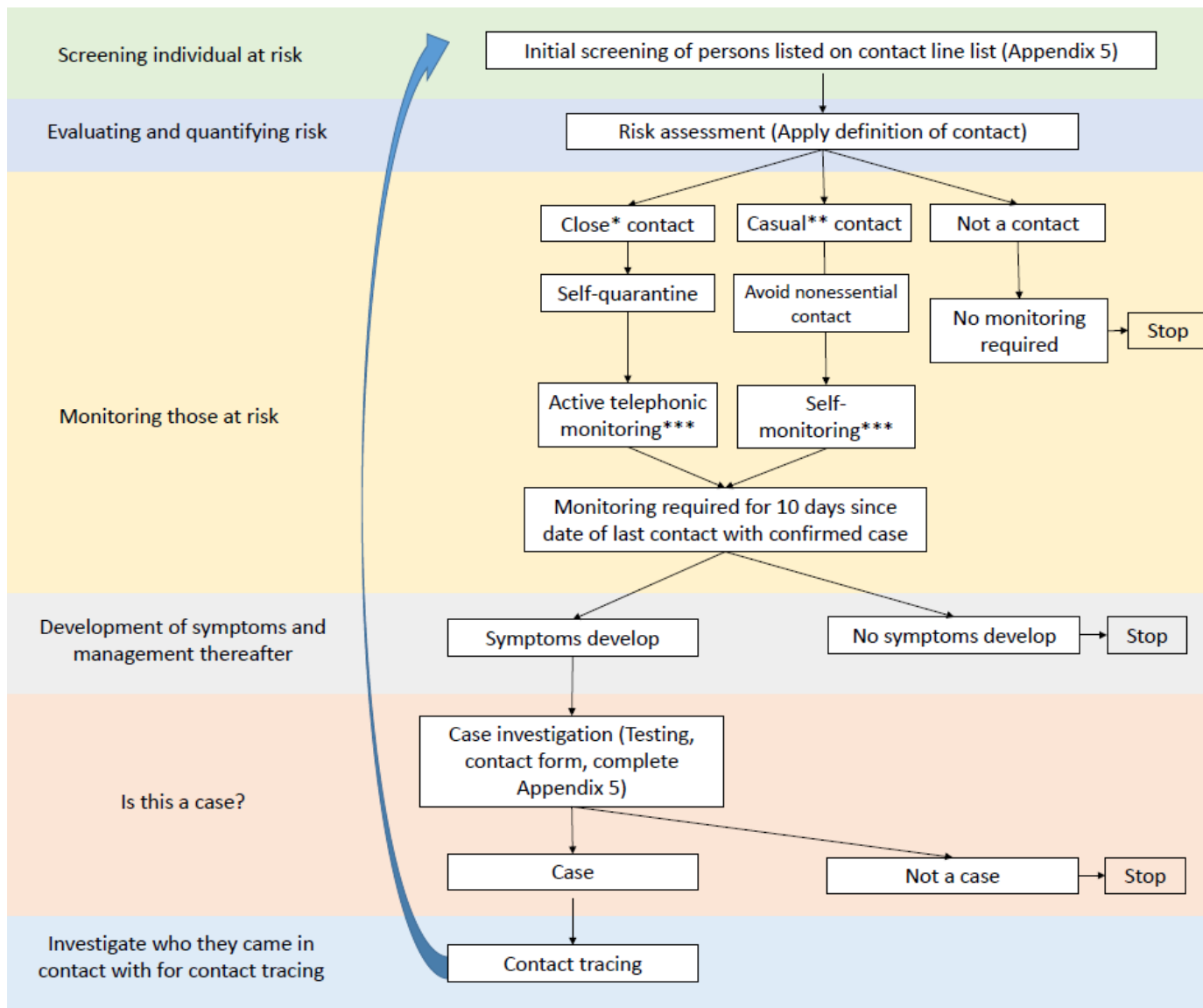

* Close contact: A person having had face-to-face contact (≤ 1 metre) or was in a closed environment with a COVID-19 case in the 2 days prior to symptom onset or while symptomatic; this includes, amongst others, all persons living in the same household as a COVID-19 case and, people working closely in the same environment as a case. A healthcare worker or other person providing direct care for a COVID-19 case, while not wearing recommended personal protective equipment or PPE (e.g., gowns, gloves, NIOSH-certified disposable N95 respirator, eye protection). A contact in an aircraft sitting within two seats (in any direction) of the COVID-19 case, travel companions, and crew members serving in the section of the aircraft where index case was seated.

** Casual contact: Anyone not meeting the definition for a close contact but with possible exposure.

*** Monitoring methods: Active-telephonic monitoring: DoH call centre will phone person who is home-quarantined each day for a symptom report; Self-monitoring: person to consult healthcare practitioner in the event of symptom development.

Appendix 3: Collection of nasopharyngeal swab, oropharyngeal swab, mid-turbinate and anterior nares swab or nasopharyngeal aspirate

Type of swabs

Only nylon or rayon flocked nasopharyngeal and oropharyngeal swabs with perforated, flexible plastic shaft must be used for collection of specimens. There is evidence to suggest some benefit to using flocked swabs for recovery of pathogens over other types. An appropriate size of the nasopharyngeal swab should be used, paediatric swab for children and adult swab for older children and adults. Cotton-tipped, calcium alginate swabs or swabs with wooden shafts should not be used as residues present in these materials may inhibit PCR assays.

Collection of a nasopharyngeal specimen

1. Ask the patient to tilt his/her head back slightly.
2. Gently insert swab into the nostril, aiming backwards (not upwards) until a slight resistance is met – about the distance from the nose to the anterior ear. If resistance is met before fully inserted, remove and try the other nostril.
3. Rotate swab 2-3 times and hold in place for 2-3 seconds.
4. Slowly withdraw the swab and put it into the specimen tube containing universal transport medium.
5. Break the swab's shaft and close the tube.

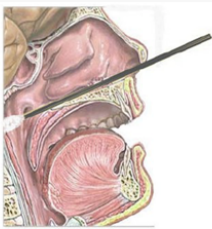

Collection of an oropharyngeal specimen

1. Ask the patient to tilt his/her head back and open their mouth.
2. Hold the tongue down with a tongue depressor.
3. Have the patient say "aahh" to elevate the uvula.
4. Swab each tonsil first, then the posterior pharynx in a "figure 8" movement.
5. Avoid swabbing the soft palate or the tongue as this can induce the gag reflex.
6. Place the swab into the same specimen tube.
7. Break the swab's shaft and close the tube tightly.

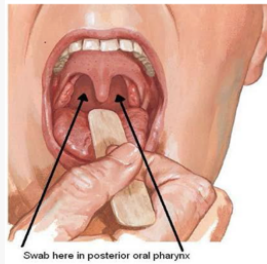

Collection of a mid-turbinate specimen

1. Ask the patient to tilt his/her head back slightly.
2. Gently insert swab less than 2cm into the nostril (until resistance is met at the turbinates).
3. Gently rotate swab several times against the nasal wall.
4. Repeat in the other nostril using the same swab.
5. Withdraw the swab and put it into the specimen tube containing universal transport medium.
6. Break the swab's shaft and close the tube.

Collection of an anterior nares (nasal) specimen

1. Ask the patient to tilt his/her head back slightly.
2. Insert the swab at least 1 cm inside the nares.
3. Firmly sample the nasal membrane by rotating the swab and leaving it in place for 10-15 seconds.
4. Sample both nares with the same swab.
5. Withdraw the swab and put it into the specimen tube containing universal transport medium.
6. Break the swab's shaft and close the tube.

Use appropriate airborne precautions during specimen collection.

Nasopharyngeal aspirates

- Fill syringe with 2-3 ml saline; attach catheter tubing to syringe tip
- Slowly insert the catheter into one nostril until the pharyngeal wall is reached

- Quickly inject saline into nostril and then aspirate the recoverable nasopharyngeal specimen
- Withdraw the catheter under suction, being careful not to touch the tip
- Inject the aspirated fluid into a labelled sterile specimen container/ universal transport medium
- Refrigerate at 2-8 °C



Figure 2: Flocked swab and Universal Transport Medium

Appendix 4: Procedures for submission of specimens for investigation

Step 1: Submit specimens for specialized laboratory investigation

- Clearly label each specimen with the patient name, date of birth and sample type.
- The specimens should be stored and shipped at 2-8°C (cooler box with ice packs). Specimens should be packaged in accordance with the guidelines for the transport of biological goods and transported directly and urgently.
- Transport specimens to NHLS or private testing laboratory on same day as specimen collection.
- Ensure that the completed laboratory request form accompanies the specimens
- Avoid repeated freezing and thawing of specimens

Packaging and transport of samples

- Patient specimens from suspected for confirmed COVID-19 cases should be transported as Biological Substance Category B.
- For local and national shipments, specimens should be placed in a secondary container (sealed Ziploc bag), to minimise potential for spill, and transported in a clearly marked cooler box with ice packs.
- For international or air shipments, specimens should be triple packaged according to the IATA guidelines for Category B Biological substances

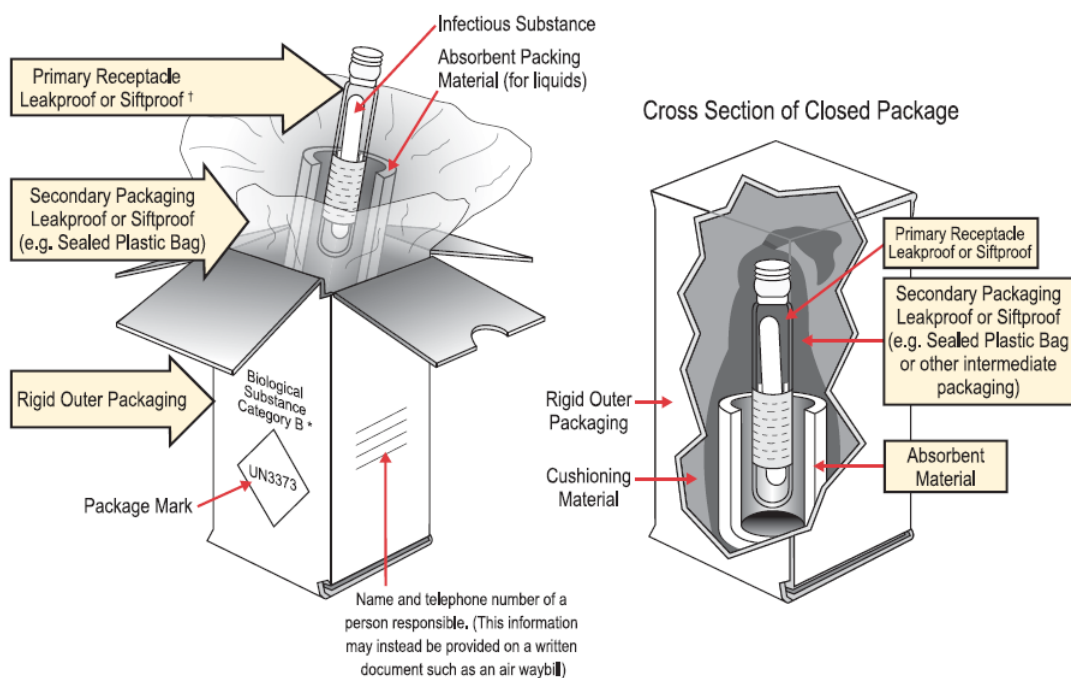

Figure 1. Example of the triple packaging system for the packing and labelling of Category B Biological substances for international shipment of clinical specimens.

It is required that designated staff members per site are trained by approved provider in the packaging and transport of dangerous goods. The IATA or WHO websites may be consulted for international regulations and guidelines in this regard. **Primary specimen containers** (properly labelled) should be wrapped in sufficient absorbent material (paper towels or tissues) to absorb the entire contents in the event of leakage. The wrapped primary containers must be placed in durable, leak-proof **secondary containers** such as several layers of sealed plastic bags or, preferably, rigid screw-cap metal, plastic or similar containers (suitable containers are usually available from hospital dispensaries). The secondary container should be taped closed to prevent leakage. The secondary containers and data forms, sealed separately in plastic, must then be placed in a **rigid outer (tertiary) container** such as a fibre carton or polystyrene cold box with cold packs.

Appendix 5: Contact tracing and contact line list

Initial contact with contact of confirmed case

Each individual on the contact line list will be contacted

- Introduce yourself and specify where you are calling from
- Explain the following:
 - Someone that tested positive for COVID-19 indicated that they were in close contact with them
 - This means that they are at risk and need to be monitored for 10 days after their exposure to the person to monitor symptoms
- Ask about the last contact with the case and establish if the person is a close contact. See definition of a close contact in guidelines.
- If person is a close contact, continue with information below. If not, inform the casual contact that they have a low risk and should contact their healthcare provider should they develop any symptoms.
- Ask if the person is experiencing any of the listed symptoms on the symptom monitoring tool
 - If yes:
 - Suspected COVID-19 case should be referred for testing through local pathways.
 - Should the test come back positive, they will be managed for COVID-19
 - Should the test come back negative, they should continue to self-monitor every day. Should symptoms worsen, contact healthcare worker/outbreak team or present to nearest facility.
 - This will continue until day 10 after last exposure to the case.
 - If not:
 - Person must self-monitor for symptoms daily
 - This will continue until day 10 after last exposure to the case.
- During the monitoring period, individuals should self-quarantine at home
 - This means they should not go to work, school, church, shops, visit friends, have friends or non-household members over, etc.
 - If the contact is a healthcare worker, they should work with a surgical mask if asymptomatic. If symptomatic, they should self-quarantine. Refer to guidelines for essential workers.
 - If living with other individuals, the contact and their household members should:
 - Perform hand hygiene frequently, using alcohol-based hand rub if hands are not visibly soiled or soap and water when hands are visibly soiled;
 - Keep distance from affected individual as much as possible (at least 1 meter);
 - Wear a medical mask when in the same room with the affected individual; replacing mask if damp, dispose of the material immediately after use;
 - Clean hands immediately after contact with respiratory secretions;
 - improve airflow in living space by opening windows as much as possible.

PDF version at: <https://www.nicd.ac.za/diseases-a-z-index/covid-19/covid-19-resources/>

COVID-19 CONTACT LINE LIST

Complete a contact line list for every person under investigation for Coronavirus disease 2019 (COVID-19).

Details of person under investigation/confirmed COVID-19 case

RSA Identity number / Passport number _____ Residential address _____

First name _____

Surname _____ District _____

Contact number _____ Province _____

Date of birth _____ Date of sample collection _____ Testing laboratory _____

Details of contacts (With close contact¹ from 2 days prior to symptom onset, or during symptomatic illness.)

| | Surname | First name(s) | Sex (M/F) | Age (Y) | Relation to case ² | Date of last contact with case | Place of last contact with case (Provide name and address) | Residential address (for next month) | Phone number(s), separate by semicolon | HCW ³ or school-going/teacher? (Y/N) If Yes, facility/school name |
|---|---------|---------------|-----------|---------|-------------------------------|--------------------------------|--|--------------------------------------|--|--|
| 1 | | | | | | DD/MM/YYYY | | | | |
| 2 | | | | | | DD/MM/YYYY | | | | |
| 3 | | | | | | DD/MM/YYYY | | | | |
| 4 | | | | | | DD/MM/YYYY | | | | |
| 5 | | | | | | DD/MM/YYYY | | | | |
| 6 | | | | | | DD/MM/YYYY | | | | |
| 7 | | | | | | DD/MM/YYYY | | | | |
| 8 | | | | | | | | | | |

¹ Close contact: A person having had face-to-face contact (≤1 metre) or was in a closed environment with a COVID-19 case; this includes, amongst others, all persons living in the same household as a COVID-19 case and, people working closely in the same environment as a case. A healthcare worker or other person providing direct care for a COVID-19 case, while not wearing recommended personal protective equipment or PPE (e.g., gowns, gloves, NIOSH-certified disposable N95 respirator, eye protection). A contact in an aircraft sitting within two seats (in any direction) of the COVID-19 case, travel companions or persons providing care, and crew members serving in the section of the aircraft where the index case was seated. ² Chose from: Spouse, Aunt, Child, Class mate, Colleague, Cousin, Father, Friend, Grandfather, Grandmother, Healthcare worker taking care of, Mother, Nephew, Niece, Other relative, Uncle. ³ Healthcare worker.

Details of contacts (With contact¹ from the date of symptom onset, or during symptomatic illness.)

| | Surname | First name(s) | Sex (M/F) | Age (Y) | Relation to case ² | Date of last contact with case | Place of last contact with case (Provide name and address) | Residential address (for next month) | Phone number(s), separate by semicolon | HCW ³ or school-going/teacher? (Y/N) If Yes, facility/school name |
|----|---------|---------------|-----------|---------|-------------------------------|--------------------------------|--|--------------------------------------|--|--|
| 9 | | | | | | DD/MM/YYYY | | | | |
| 10 | | | | | | DD/MM/YYYY | | | | |
| 11 | | | | | | DD/MM/YYYY | | | | |
| 12 | | | | | | DD/MM/YYYY | | | | |
| 13 | | | | | | DD/MM/YYYY | | | | |
| 14 | | | | | | DD/MM/YYYY | | | | |
| 15 | | | | | | DD/MM/YYYY | | | | |
| 16 | | | | | | DD/MM/YYYY | | | | |
| 17 | | | | | | DD/MM/YYYY | | | | |
| 18 | | | | | | DD/MM/YYYY | | | | |
| 19 | | | | | | DD/MM/YYYY | | | | |
| 20 | | | | | | DD/MM/YYYY | | | | |
| 21 | | | | | | DD/MM/YYYY | | | | |

¹ Close contact: A person having had face-to-face contact (≤1 metre) or was in a closed environment with a COVID-19 case; this includes, amongst others, all persons living in the same household as a COVID-19 case and, people working closely in the same environment as a case. A healthcare worker or other person providing direct care for a COVID-19 case, while not wearing recommended personal protective equipment or PPE (e.g., gowns, gloves, NIOSH-certified disposable N95 respirator, eye protection). A contact in an aircraft sitting within two seats (in any direction) of the COVID-19 case, travel companions or persons providing care, and crew members serving in the section of the aircraft where the index case was seated. ² Chose from: Spouse, Aunt, Child, Class mate, Colleague, Cousin, Father, Friend, Grandfather, Grandmother, Healthcare worker taking care of, Mother, Nephew, Niece, Other relative, Uncle. ³ Healthcare worker.



COVID-19 DAILY SYMPTOM MONITORING TOOL



Complete for contact of a confirmed Coronavirus disease 2019 (COVID-19) case

| Details of <u>contact</u> of confirmed case (details of case completed just before instructions) | | | | Details of health official completing this form | | Date completing form | |
|--|--|-------------------------------|--|---|----------------------------|----------------------|------------|
| NICD Identifier | Date of contact | DD/MM/YYYY | Place last contact | Surname | Name | DD/MM/YYYY | |
| Surname | Name | | | Role | Facility name | | |
| Date of birth | DD/MM/YYYY | Age (Y) | Sex M <input type="checkbox"/> F <input type="checkbox"/> | Email address | Telephone number | | |
| Healthcare worker | Y <input type="checkbox"/> N <input type="checkbox"/> | If yes, facility name | | Next of kin details | | | |
| Contact number(s) | Email | | | Next of Kin name and surname | Next of Kin contact number | | |
| Physical address | | | | | | | |
| House number | Street | | Suburb | Town | | | |
| District | Province | | Patient traced Y <input type="checkbox"/> N <input type="checkbox"/> | | | | |
| Details of <u>confirmed</u> COVID-19 case | | | | | | | |
| Contact type ¹ | Close <input type="checkbox"/> Casual <input type="checkbox"/> | Relation to case ² | | NICD identifier | Surname | DOB | DD/MM/YYYY |

Instructions for completion: Mark “Y” if symptom present and “N” if not. If any symptoms are present collect, contact 082 883 9920 immediately and make immediate arrangements for the collection of a specimen. Refer to COVID-19 Quick Guide on the NICD website for additional details. Days post exposure to case.

| DAY | 1 | 2 | 3 | 4 | 5 | 6 | 7 | 8 | 9 | 10 |
|--------------------------------|---|---|---|---|---|---|---|---|---|---|
| Date (DD/MM) | | | | | | | | | | |
| Measured body temp | | | | | | | | | | |
| Fever (self-reported) | <input type="checkbox"/> Y <input type="checkbox"/> N | <input type="checkbox"/> Y <input type="checkbox"/> N | <input type="checkbox"/> Y <input type="checkbox"/> N | <input type="checkbox"/> Y <input type="checkbox"/> N | <input type="checkbox"/> Y <input type="checkbox"/> N | <input type="checkbox"/> Y <input type="checkbox"/> N | <input type="checkbox"/> Y <input type="checkbox"/> N | <input type="checkbox"/> Y <input type="checkbox"/> N | <input type="checkbox"/> Y <input type="checkbox"/> N | <input type="checkbox"/> Y <input type="checkbox"/> N |
| Chills | <input type="checkbox"/> Y <input type="checkbox"/> N | <input type="checkbox"/> Y <input type="checkbox"/> N | <input type="checkbox"/> Y <input type="checkbox"/> N | <input type="checkbox"/> Y <input type="checkbox"/> N | <input type="checkbox"/> Y <input type="checkbox"/> N | <input type="checkbox"/> Y <input type="checkbox"/> N | <input type="checkbox"/> Y <input type="checkbox"/> N | <input type="checkbox"/> Y <input type="checkbox"/> N | <input type="checkbox"/> Y <input type="checkbox"/> N | <input type="checkbox"/> Y <input type="checkbox"/> N |
| Cough | <input type="checkbox"/> Y <input type="checkbox"/> N | <input type="checkbox"/> Y <input type="checkbox"/> N | <input type="checkbox"/> Y <input type="checkbox"/> N | <input type="checkbox"/> Y <input type="checkbox"/> N | <input type="checkbox"/> Y <input type="checkbox"/> N | <input type="checkbox"/> Y <input type="checkbox"/> N | <input type="checkbox"/> Y <input type="checkbox"/> N | <input type="checkbox"/> Y <input type="checkbox"/> N | <input type="checkbox"/> Y <input type="checkbox"/> N | <input type="checkbox"/> Y <input type="checkbox"/> N |
| Sore throat | <input type="checkbox"/> Y <input type="checkbox"/> N | <input type="checkbox"/> Y <input type="checkbox"/> N | <input type="checkbox"/> Y <input type="checkbox"/> N | <input type="checkbox"/> Y <input type="checkbox"/> N | <input type="checkbox"/> Y <input type="checkbox"/> N | <input type="checkbox"/> Y <input type="checkbox"/> N | <input type="checkbox"/> Y <input type="checkbox"/> N | <input type="checkbox"/> Y <input type="checkbox"/> N | <input type="checkbox"/> Y <input type="checkbox"/> N | <input type="checkbox"/> Y <input type="checkbox"/> N |
| Shortness of breath | <input type="checkbox"/> Y <input type="checkbox"/> N | <input type="checkbox"/> Y <input type="checkbox"/> N | <input type="checkbox"/> Y <input type="checkbox"/> N | <input type="checkbox"/> Y <input type="checkbox"/> N | <input type="checkbox"/> Y <input type="checkbox"/> N | <input type="checkbox"/> Y <input type="checkbox"/> N | <input type="checkbox"/> Y <input type="checkbox"/> N | <input type="checkbox"/> Y <input type="checkbox"/> N | <input type="checkbox"/> Y <input type="checkbox"/> N | <input type="checkbox"/> Y <input type="checkbox"/> N |
| Anosmia/Dysgeusia ³ | <input type="checkbox"/> Y <input type="checkbox"/> N | <input type="checkbox"/> Y <input type="checkbox"/> N | <input type="checkbox"/> Y <input type="checkbox"/> N | <input type="checkbox"/> Y <input type="checkbox"/> N | <input type="checkbox"/> Y <input type="checkbox"/> N | <input type="checkbox"/> Y <input type="checkbox"/> N | <input type="checkbox"/> Y <input type="checkbox"/> N | <input type="checkbox"/> Y <input type="checkbox"/> N | <input type="checkbox"/> Y <input type="checkbox"/> N | <input type="checkbox"/> Y <input type="checkbox"/> N |

¹ Close contact: A person having had face-to-face contact (≤1 metre) or in a closed space with a COVID-19 case for at least 15 minutes while symptomatic or in the 2 days prior to symptom onset. This includes, amongst others, all persons living in the same household as a COVID-19 case and, people working closely in the same environment as a case. A healthcare worker or other person providing direct care for a COVID-19 case, while **not** wearing recommended personal protective equipment or PPE (e.g., gowns, gloves, N95 respirator, eye protection). A contact in an aircraft sitting within two seats (in any direction) of the case, travel companions or persons providing care, and crew members serving in the section of the aircraft where the case was seated.

² Chose from: Spouse, Aunt, Child, Classmate, Colleague, Cousin, Father, Friend, Grandfather, Grandmother, Healthcare worker, Mother, Nephew, Niece, Other relative, Uncle. ³ Loss of sense of smell or altered sense of taste.

Appendix 7: Enhanced COVID-19 Notifiable Medical Conditions (NMC) Notification Form



Enhanced COVID-19 Notifiable Medical Conditions (NMC) Notification Form

(Section 90 (1) (j), (k) and (w) of National Health Act, 2003 (Act no. 61 of 2003))

This form must be **completed immediately** by the health care provider who diagnosed the condition *Please mark applicable areas with an X*



| | | | | | |
|---|--|---|--|---|--|
| Health facility name (with provincial prefix) | | Health facility contact number | | Health district | |
| Patient file/folder number | | Patient HPRS-PRN | | Date of notification | |
| | | | | y y y y - m m - d d | |
| Patient demographics | | | | Patient residential address | |
| First name | | Street/dwelling unit/building/ERF number | | | |
| Surname | | Street name, building, location description | | | |
| RSA ID/Passport number | | Sub-place, suburb, village, postal area | | | |
| Citizenship | | Town/city | | | |
| | | Post code: | | | |
| Ethnic group | | Black African | | Coloured | |
| | | Indian/Asian | | White | |
| | | Other | | Employer/educational institution address | |
| Date of birth | | Institution name | | | |
| y y y y - m m - d d | | Street name, building, location description | | | |
| Age | | Sub-place, suburb, village, postal area | | | |
| Years | | Months (if less than 1 year) | | Days (if less than 1 month) | |
| Gender | | Town/city | | | |
| Male | | Female | | Post code: | |
| Contact number | | Alternative contact number | | | |
| Next of kin | | | | Contact number | |
| Name | | | | | |
| Surname | | Occupation | | | |
| Relationship to the patient | | Unemployed | | Student | |
| | | Healthcare worker | | | |
| Contact number | | Health laboratory worker | | Other (specify) | |
| Medical condition details | | | | Hospitalisation | |
| Medical condition | | Admission status | | Outpatient | |
| This form is for notifying COVID-19 case only | | Clinically required hospitalisation | | Inpatient | |
| Was the patient previously tested for COVID-19? | | Yes | | No | |
| Yes (if repeat test) | | No (if first test) | | Unknown | |
| Date of symptom onset | | Date of admission | | Level of care | |
| y y y y - m m - d d | | y y y y - m m - d d | | General ward | |
| Symptoms | | If High Care/ICU | | High Care | |
| Fever (≥38°C) | | Date entered High Care/ICU | | ICU | |
| Sore throat | | y y y y - m m - d d | | | |
| Cough | | Date exited High Care/ICU | | | |
| Shortness of breath | | y y y y - m m - d d | | | |
| Myalgia/body aches | | Oxygen requirements during hospitalisation | | | |
| Diarrhea | | Room air | | Nasal cannula oxygen | |
| Other | | Mechanical ventilation | | | |
| Case severity | | Rapid test | | Start date | |
| Asymptomatic | | X-Ray | | y y y y - m m - d d | |
| Mild ¹ | | Other | | End | |
| Moderate ² | | Laboratory confirmed | | y y y y - m m - d d | |
| Severe ³ | | Source of PUI ⁴ | | ECMO | |
| Date of diagnosis | | Field testing | | Start date | |
| y y y y - m m - d d | | Health facility | | y y y y - m m - d d | |
| Method of diagnosis | | Healthcare professional | | End | |
| Clinical signs and symptoms ONLY | | Name of source of PUI | | y y y y - m m - d d | |
| Rapid test | | Patient received systemic antimicrobial treatment during hospital admission for a probable or confirmed healthcare-associated infection | | Yes | |
| X-Ray | | | | No | |
| Other | | | | Unknown | |
| Laboratory confirmed | | | | | |

¹Mild - not requiring hospitalization for clinical reasons

²Moderate - requiring hospitalization

³Severe - requiring high care/ICU

⁴PUI - Person under investigation

Enhanced COVID-19 Notifiable Medical Conditions (NMC) Notification Form

(Section 90 (1) (j), (k) and (w) of National Health Act, 2003 (Act no. 61 of 2003))

This form must be **completed immediately** by the health care provider who diagnosed the condition *Please mark applicable areas with an X*

| Underlying factors/comorbid conditions | | | | Hospital outcome | | | | | | | | | | | | | |
|---|--------------------|----------------|-----------|--|------------|---|--------------------|-------------|---|------------------------------------|---|---|---|------|----|---|---|
| HIV | Yes | No | Unknown | Status | Discharged | | | In hospital | | | Transferred | | | Died | | | |
| TB | Yes | No | Unknown | If discharged, date | y | y | y | y | y | - | m | m | - | d | d | | |
| COPD | Yes | No | Unknown | If died, date | y | y | y | y | y | - | m | m | - | d | d | | |
| Hypertension | Yes | No | Unknown | Outcome of patient cared for at home after 14 days of symptom onset/test date | | | | | | | | | | | | | |
| Diabetes | Yes | No | Unknown | Alive, asymptomatic | | | Alive, symptomatic | | | Died | | | | | | | |
| Asthma | Yes | No | Unknown | Specimen details | | | | | | | | | | | | | |
| Obesity | Yes | No | Unknown | Was the specimen collected | | | Yes | | | No | | | | | | | |
| Pregnancy | Yes | No | Unknown | Date of collection | | | y | y | y | y | y | - | m | m | - | d | d |
| Cancer | Yes | No | Unknown | Specimen barcode/lab number | | | | | | | | | | | | | |
| If TB, is patient on TB treatment | Yes | No | Unknown | Travel history in the last 14 days | | | | | | | | | | | | | |
| If yes, TB treatment start date | y | y | y | y | - | m | m | - | d | d | Did patient travel outside of usual place of residence? | | | Yes | No | | |
| If living with HIV, is patient on ART? | Yes | No | Unknown | Place travelled from | | | Place travelled to | | | Date left usual place of residence | | | Date returned to usual place of residence | | | | |
| If yes, is there viral suppression? | Yes | No | Unknown | | | | | | | | | | | | | | |
| History of close physical contact with confirmed COVID-19 case in past 14 days | | | | | | | | | | | | | | | | | |
| Close physical contact with a known COVID-19 case | | Yes | No | Unknown | | | | | | | | | | | | | |
| If yes, please indicate the contact setting | | | | | | | | | | | | | | | | | |
| Quarantine Centre | Healthcare setting | Family setting | Workplace | | | | | | | | | | | | | | |
| Other, specify | | | | | | | | | | | | | | | | | |
| Notifying health care provider's details | | | | | | | | | | | | | | | | | |
| First name | | | | Mobile number | | | | | | | | | | | | | |
| Surname | | | | Email address | | | | | | | | | | | | | |
| Notifier's signature | | | | SANC/HPCSA number | | | | | | | | | | | | | |

Send to NMCsurveillanceReport@nicd.ac.za or fax to 086 639 1638, or NMC hotline 072 621 3805, and to the sub-district/district office

Appendix 8: Contact details (email address and telephone) of stakeholders involved in supporting outbreak response.

| Institution/Province | Name | Email address | Telephone number |
|--|--|--|--|
| National Department of Health | | | |
| Communicable Disease Control | Tsakani Furumele | Tsakani.Furumele@health.gov.za | 012 395 8096 / 0824199686 |
| Malaria, Vector-borne and Zoonotic Diseases | Devanand Moonasar Wayne Ramkrishna | Patric.Moonasar@health.gov.za Wayne.Ramkrishna@health.gov.za | 082 578 3107 082 317 4687 |
| Port Health | Funeka Bongweni | Funeka.Bongweni@health.gov.za | 012 395 9728 / 0609930107 |
| Environmental Health | Murdock Ramathuba | Murdock.Ramathuba@health.gov.za | 012 395 8518 / 0814150093 |
| Emergency Medical Services | Raveen Naidoo Ahmed Bham | Raveen.Naidoo@health.gov.za Ahmed.Bham@health.gov.za | 012 395 821 012 395 9636 / 0735716392 |
| Hospital Services | Keneilwe Modise | Keneilwe.Modise@health.gov.za | 012 395 8257 / 0829648888 |
| Infection Prevention and Control | Ronel Steinhobel | Ronel.Steinhobel@health.gov.za | 012 395 9198 / 0836275661 |
| Provincial Communicable Disease Control Directorate | | | |
| Eastern Cape | Thomas Dlamini | thomas.dlamini@ehealth.gov.za | 083 378 0189 |
| Free State | Dikeledi Baleni Babsy Nyokong | balenid@fshealth.gov.za nyokongb@fshealth.gov.za | 083 757 8217 082 463 7499 |
| Gauteng | Chika Asomugha Caroline Kesebilwe | Chika.Asomugha@gauteng.gov.za Caroline.kesebilwe@gauteng.gov.za | 082 330 1490 083 490 8165 |
| KwaZulu-Natal | Premi Govender | premi.govender@kznhealth.gov.za | 071 609 2505 |
| Limpopo | Marlene Freda Ngobeni Mashudu P. Mudau | Marlene.Ngobeni@dhsd.limpopo.gov.za Prudence.Mudau@dhsd.limpopo.gov.za | 079 491 1909 071 678 3864 |
| Mpumalanga | Mandla Zwane Hluphi Mpangane | MandlaZw@mpuhealth.gov.za hluphim@mpuhealth.gov.za | 082 229 8893 076 522 8511 013 766 3411 |
| North West | Chriseldah Lebeko | clebeko@nwpg.gov.za | 082 421 7985 |
| Northern Cape | Gloria Hottie | hottieg@webmail.co.za | 072 391 3345 053 830 0529 |
| Western Cape | Charlene Lawrence | Charlene.lawrence@westerncape.gov.za | 072 356 5146 021 483 9964 |
| Port Health and Environmental Health | | | |
| Central Region (Gauteng, Free-State, Northern Cape) | Funeka Bongweni | Funeka.Bongweni@health.gov.za | 012 395 9728 060 993 0107 |
| Northern Region (Limpopo, Mpumalanga, North West) | Ockert Jacobs | Ockert.Jacobs@health.gov.za | 012 395 9417 082 372 0556 |
| Coastal Region (KwaZulu Natal, Northern Cape, Western Cape) | Antoinette Hargreaves | Antoinette.Hargreaves@health.gov.za | 031 301 0381 083 460 0935 |
| Emergency Medical Services (EMS)- see table below | | | |
| National Institute for Communicable Diseases (NICD) | | | |
| Hotline (24-hours) | Public or clinicians | | 0800 029 999 |
| Laboratory | Anne von Gottberg | annev@nicd.ac.za | 082 572 0057 |
| | Nicole Wolter | nicolew@nicd.ac.za | 083 285 8708 |
| | Jinal Bhiman | jinalb@nicd.ac.za | 066 363 4511 |

| | | | |
|-------------------------------|-------------------|--|--------------|
| | Mignon du Plessis | mignond@nicd.ac.za | 083 564 6747 |
| Case Management | Kerrigan McCarthy | kerriganm@nicd.ac.za | 0798717278 |
| Epidemiology and Surveillance | Sibongile Walaza | sibongilew@nicd.ac.za | 083 657 4741 |
| | Jackie Kleynhans | jackiek@nicd.ac.za | |
| | Genevieve Ntshoe | genevien@nicd.ac.za | |

| PROVINCE | Contact Details | Contact Persons |
|---|--|--|
| National Department of Health: EMS & Disaster Medicine Directorate | 012 395 9636 / 081 324 4555 012395 9636 / 073 571 6392 | Mr Raveen Naidoo (Director) Mr Ahmed Bham (EMS Operational Manager – Disaster Medicine) |
| Gauteng | 011 564 2211 / 072 433 7450 011 564 2021 | Mr. J.P. Von Benecke Mr Kgati Malebane (Director EMS) |
| Western cape | 012 937 0300 082 568 6489 / 021 948 9908 | Mr. Arthur van Heerden Dr S De Vries (Director EMS) |
| Kwazulu Natal | 0834571242 083 501 1955 / 033 846 7237 | Mr M Mabaso Ms B Zungu (Director EMS) |
| Free State | 0609856082 082 659 1600 / 051 408 1855 | Mr R Ruiters (Provincial EMS Ops Manager) Dr Joe Khoali (Director EMS) |
| North West | 082 335 6034 / 018 473 0324 | Mr B Redlinghys (Director EMS) |
| Limpopo | 082 040 5494 082 440 0802 / 015 295 2999 | Mr F Masegela Dr Clive Sibanda (Director EMS) |
| Northern Cape | 053 802 2280 / 053 831 1954/5 083 335 6034 / 053 831 2884 | Mr R. Dreyer Mr M Ntintelo (Director EMS) |
| Mpumalanga | 013 753 2288/ 082 907 3256 013 766 3302 / 082 828 6223 | Mr. Scosh Mkhonto Mr Zungu (Director EMS) |
| Eastern Cape | 060 572 9172 / 060 572 9172 | Mr AK Munilil (Director EMS) |

NHLS laboratory contact details:

Eastern Cape Province:

Port Elizabeth Provincial Hospital Lab 041 395 6120

Nelson Mandela Academic Hospital Lab 047 502 4886

Free State Province:

Universitas Virology Laboratory 051 405 3162/2834

Pelonomi Hospital Laboratory 051 405 9341

Gauteng Province:

Charlotte Maxeke Laboratory 011 489 8880

Tshwane Virology Laboratory 012 319 2509

DGM Virology Laboratory 012 521 4217

Tambo Memorial Hospital Laboratory 011 917 9605

KwaZulu Natal Province:

Inkosi Albert Luthuli Academic Laboratory 031 240 2794

Addington Hospital Laboratory 031 327 2463

Limpopo Province:

Mankweng Provincial Hospital Laboratory 015 267 6530

Polokwane Hospital Laboratory 015 297 1099/1100

Mpumalanga Province:

Rob Ferreira Hospital Laboratory 013 741 1014

North West Province:

Tshepong Hospital Laboratory 018 465 4988

Rustenburg Hospital Laboratory 014 592 2792

Western Cape Province:

Green Point Laboratory 021 417 9354

Groote Schuur Virology Laboratory 021 404 5067/5202

Tygerberg Virology Laboratory 021 938 4330/9355