

Rehabilitation in field hospitals

Early and effective rehabilitation in emergencies can greatly improve quality of care as well as the lives of patients with impairments.

Making accommodations within a field hospital structure for those with restricted mobility can have significant advantages; accessible pathways, latrines and doorways mean patients can be more independent and less reliant on nurses and other care providers. The following pages provide some basic guidance for how field hospitals can be made more accessible.

Allocating a designated space for rehabilitation (such as an allocated tent) ensures there is room for clinicians to work effectively with patients and their families. This space can accommodate (at a minimum) a plinth, parallel bars and storage space for rehabilitation equipment and consumables.

4m

Accessibility and allocation of space for rehabilitation in field hospitals



For more about WHO's technical standards and recommendations for rehabilitation visit: <https://extranet.who.int/emt/> download the 'Minimum Standards for Rehabilitation' document under 'Resources'



World Health Organization

Ramps and Doorways

Ramps

- All pathways to patient areas should be level or have ramps to ensure patients have safe and independent access
- Ramps should be added (at a gradient of 1:20) if there is a rise to the door
- Where possible handrails should be included

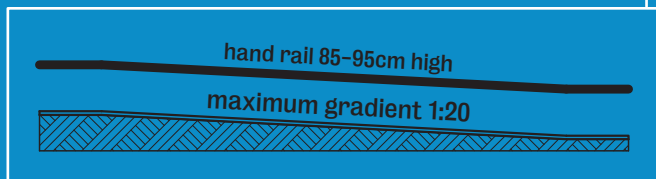

Setting up field hospitals to facilitate patient mobility ensures quality care and faster recovery.

Doorways

- Make sure anybody in a wheelchair can get through doors by making them at least 90cm wide
- Sliding doors are ideal, otherwise use doors which open outwards
- Door handles should be easy to grip with one hand eg. a lever or pull handle

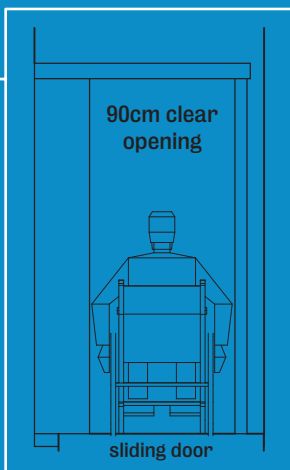

Showers and Washrooms

- Showers should have a seat which is positioned for easy access to the water source
- The water source should be easy to reach
- A grab bar should be secured around the wall, at a height of 85-95cm
- Step-down facilities should design washrooms similar to those in the host country

Making showers and washrooms as close as possible to what is available in country will help people transition more easily from the facility to their home.

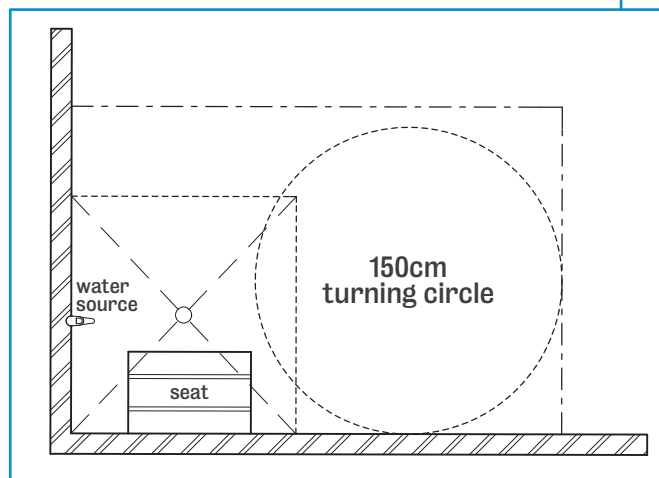

Latrines

To meet the needs of patients with limited mobility, latrines should be designed with enough space for patients to manoeuvre and be assisted by staff or family.

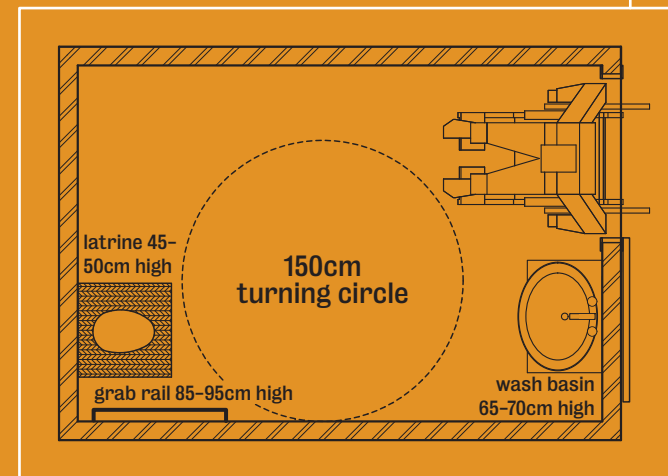

- A grab rail should be secured next to the toilet
- The wash basin should be placed low enough to be reached by someone in a wheelchair
- Wash basin taps should also be designed to be used easily by wheelchair users
- At least one latrine in every field hospital should be gender neutral to allow care providers of the opposite sex to assist the patient