

Promoting Access to the Built Environment

Guidelines





Promoting Access to the Built Environment

Guidelines



CBM is an international Christian development organisation whose primary purpose is to improve the quality of life of persons with disabilities and their families in the most marginalised societies in the world.

While working for and together with persons with disabilities, their families and communities, CBM advocates for meaningful and effective participation, equal rights and opportunities and full inclusion of persons with disabilities in all spheres of society.



Nibelungenstrasse 124
64625 Bensheim
Germany
Phone: +49 6251 131-0
Fax: +49 6251 131-165
E-mail: inclusion@cbm.org

Pictures:
CBM, argum/Thomas Einberger, CBM/Grossmann,
CBM/Lohnes, CBM/Jacq

Promoting and ensuring accessibility improvement is an ongoing process hence this manual is a work in progress document. CBM would like to encourage feedback and input of users and implementing persons in regard to good practices and lessons learned to ensure the continuous improvement and adaptation of the manual.



Table of Contents	Page
Preface	5
1. Introduction	1-1
1.1. The Need for Access to the Built Environment	1-2
1.2. From "Disability-Friendly" to "Design for All"	1-3
1.3. How to Implement Architectural Accessibility	1-4
1.4. Architectural Accessibility in Post-Disaster Situation	1-7
2. Anthropometrics and Measures of Assistive Devices	2-1
2.1. Wheelchair Dimensions	2-1
2.2. Pathway Dimensions	2-5
2.3. Reaching Zones	2-6
3. Visual Accessibility	3-1
3.1. Use of Colour	3-2
3.2. Lighting	3-4
3.3. Signage	3-4
4. Vertical Accessibility	4-1
4.1. Curb Ramps	4-1
4.2. Ramps	4-2
4.3. Lifts	4-6
4.4. Stairs	4-8
5. Horizontal Accessibility	5-1
5.1. Doors	5-1
5.2. Entrance Areas and Lobbies	5-4
5.3. Corridors	5-8
5.4. Handrails and Railings	5-9
5.5. Restrooms/Toilets	5-13
5.6. Showers	5-17
6. Guiding System for Blind and Visually Impaired Persons	6-1
7. Accessibility for Deaf, Hard of Hearing and Deafblind Persons	7-1
7.1. Colour and Contrast	7-1
7.2. Design and Tactile Information	7-1
7.3. Material and Acoustics	7-1
7.4. Emergency Systems	7-2



8. Appendices	8-1
8.1. Universal Accessibility Logos	8-1
8.2. The EIDD Stockholm Declaration®	8-5
8.3. Accessibility Audit	8-7
8.4. Tips on Making the Workplace Accessible	8-11
8.5. Accessibility Check List	8-15
8.6. References	8-21
9. Experience Sharing and Good Practice Examples on Accessibility	



Preface

CBM, an international Christian development organisation, advocates for full and effective participation, equal opportunities and inclusion of persons with disabilities in all spheres of society.

Accessibility is a prerequisite for inclusion; without access to buildings, transportation, social services and information, participation and full inclusion cannot be ensured.

Furthermore accessibility should not be seen as an option, but rather as an essential human right.

Creating a fully accessible environment requires the involvement of various stakeholders to develop and implement accessibility initiatives and to monitor the quality of the interventions and improvement in accessibility over time.

These stakeholders include policy makers, project coordinators, architects and builders, law enforcement and town planning officials, people with expertise in disability issues, and, most importantly, persons with disabilities themselves.

These guidelines on "Promoting Access to the Built Environment" reflect international standards and recommendations about accessibility in the built environment, and have been developed to assist CBM, its partners and other interested agencies in creating a more fully accessible environment.

Allen Foster
President, CBM

Christiane Noe
Accessibility Officer, CBM

Acknowledgements:

This publication is the result of various peoples' effort, experience and expertise. The text and content was compiled by Susanne Wilm and Christiane Noe. CBM's Working Group on Accessibility gave tremendous input during the reviewing process for this second edition. Further valuable advise has been provided by Neumann Consult. Excellent support has been given by colleagues assisting with layout, printing and distribution.

On behalf of CBM we gratefully acknowledge all these efforts.



Acronyms

DFID	Department for International Development
DPO	Disabled Peoples' Organisation / Organisations of Persons with Disabilities
DOJF	Disability Organisations Joint Front
EIDD	European Institute for Design and Disability
(I)NGO	(International) Non-Governmental Organisation
ISA	International Symbol of Access
MDGs	Millennium Development Goals
PRSP	Poverty Reduction Strategy Paper
UN	United Nations
UNCRPD	UN Convention on the Rights of Persons with Disabilities
WPA	World Programme of Action Concerning Disabled Persons

Measures and Equivalents

mm	cm	m	inch(es)	foot/feet (ft)	yards (yd)
1	0.01	0.001	0.0394	–	–
10	1	0.01	0.3937	0.0328	0.0109
1000	100	1	39.37	3.280	1.0936
–	91.44	0.9144	36	3	1
–	30.48	0.3048	12	1	0.33



Introduction



1. Introduction

According to UN estimates, between six and ten percent of the population live with disabilities – at present about 650 million people worldwide. Moreover, in low-income countries persons with disabilities are more likely to be poor than in the rest of the world. Research has shown the strong association between higher illiteracy, poor nutritional status, higher unemployment, low inoculation and immunisation coverage and lower occupational mobility and a higher disability rate. The exclusion of persons with disabilities from infrastructure, services, social contact and community activities results in limited social, educational and economic opportunities, which again increases the risk of persons with disabilities being vulnerable to become poor or falling further into poverty.

Ensuring access to the built environment is a crucial element in reducing the vulnerability and isolation of persons with disabilities: Architectural accessibility facilitates – amongst other areas of accessibility – the chances to find employment, to gain education and access public services, to participate in social and recreational activities and hence, to play an active role in society both economically and socially.

With this publication, CBM aims to provide guidance for improving access to the built environment for persons with disabilities with reducing and overcoming barriers. The publication includes information on the concept and ways of implementing accessibility and **Design for All** as well as technical recommendations and good practices for the planning and design of accessible buildings and facilities. It targets architects, planners, policy makers, government officials and NGOs, decision makers in the construction sector and persons with disabilities to promote and improve architectural accessibility throughout the world.

Local Context:

However, solutions cannot be simply transferred from one country to another as priorities, resources, conditions as well as national regulations and policies vary. Also, in many countries solutions are applied or developed informally. Therefore, this publication cannot claim to cover all requirements or possible solutions but aims to make the reader aware of possible architectural barriers and offers general guidelines and good practice assuming that many lessons learned can be exchanged between different countries, but finally local cultural factors and resources will shape the final form of accessibility standards on a national or local level.

Ensuring accessibility is an ongoing process and hence, CBM would like to encourage feedback and input of users as well as implementing persons on good practices and lessons learned to ensure the continuous improvement and adaptation of this publication.



1.1. The Need for Access to the Built Environment

The importance of including disability into the political agenda is increasingly recognised across the world. The need for promoting greater access as an effective approach to reversing exclusion and enhancing the equalisation of opportunities in a sustainable way has been adopted globally through the **UN Convention on the Rights of Persons with Disabilities (UNCRPD)**, which was approved by the General Assembly in December 2006 and entered into force in May 2008. It establishes the legal frame for policy change and actual implementation towards achieving accessibility for all.

Article 9 of the UNCRPD on **"Accessibility"** stipulates that persons with disabilities are to be enabled to live independently and participate fully in all aspects of life. This implies for States Parties to "[...] take appropriate measures to ensure to persons with disabilities access, on an equal basis with others, to the physical environment, to transportation, to information and communications, including information and communications technologies and systems, and to other facilities and services open or provided to the public, both in urban and in rural areas [...]".¹

The Standard Rules on the Equalization of Opportunities for Persons with of the year 1993 followed by the UN CRPD reflect the shift in emphasis from the medical model of disability towards a social model of disability focusing on the empowerment of persons with disabilities and the adaptation of environments in achieving equal opportunities.

Definition: **Access** is not a state or act but refers to the freedom of choice to enter, approach, communicate or make use of a situation or environment. Restraint access to the built up environment is consistently identified by persons with disabilities as a major barrier not only to social but also to educational and economic opportunities. Particularly in low-income countries, the situation of poor accessibility contributes towards the phenomenon of the cycle of disability and poverty.

Following the UN commitment of halving the proportion of people living in extreme poverty by 2015, as a major component of the Millennium Development Goals (MDGs), poverty alleviation became a crucial policy issue and many low-income countries have adopted Poverty Reduction Strategy Programs (PRSPs). However, if these international targets on poverty reduction are to be reached, the development and implementation of specific measures to reduce the prevailing exclusion and discrimination of persons with disabilities is critical. Improving their access to the built up environment and hence, amongst others to economic and educational opportunities will represent a core element in this context.

¹ <http://www.un.org/disabilities/documents/convention/convoptprot-e.pdf>



1.2. From “Disability-Friendly” to “Design for All”

Access is a very broad term that can refer to many areas such as education, transport, employment, buildings and public spaces, etc. Most of these areas are interdependent (e.g. access to the school building being one of the conditions for access to education) and as a whole ultimately account for inclusion.

During the past 20 years, various approaches and terms have been employed and used when considering architectural accessibility for persons with disabilities in the planning and construction of buildings and facilities such as disabled-friendly design, design for special needs or the concept of barrier-free design which was developed in response to the demands of the disability movement in the USA. This often led to very specialised features or micro solutions offering sometimes only limited and predetermined choices in a conventionally non-accessible macro environment. Often, this involves special solutions for special groups. However, it has to be considered that disabilities are not always stable, some are temporary and gradually disappear, while others may be progressive and become more limiting with time. Similarly, certain disabilities only affect certain areas of life and are not noticeable at all at other times. Hence, there is a great variety of abilities and capabilities that have to be recognised.

In recent initiatives, there was an increasingly felt need that accessibility must mean more than providing “direct” access to the built up environment through assistive or special features. The **Design for All** approach is clearly different from Design for the Disabled by creating environments that all people regardless of their age and abilities are able to use to the largest extent possible without the need for adaptation or specialised design. Design for All benefits all users to some degree at some point, creating a win-win situation. (EIDD – Design for All Europe).

Definition: **Design for All** is a concept that considers **all** potential users of a building or environment:

“Design for All is design for human diversity, social inclusion and equality. [...] Design for All aims to enable all people to have equal opportunities to participate in every aspect of society. To achieve this, the built environment, everyday objects, services, culture and information – in short, everything that is designed and made by people to be used by people – must be accessible, convenient for everyone in society to use and responsive to evolving human diversity.”²

Local Context: However, the economic, social and cultural realities of low-income countries affect this approach significantly: The prevalence of oppressing sociopolitical and economic realities such as poverty, illiteracy and the lack of infrastructure call for vastly different solutions. It is hence challenging to apply the concept of Design for All with its origins stemming from the European context in low-resource set-

² see the Stockholm Declaration in the Annexure; www.designforalleurope.org



tings. Anyhow the concept is flexible for creative and context specific solutions, due to its multidisciplinary approach.

1.3. How to Implement Architectural Accessibility

Globally, there has been progress in reducing barriers in the built up environment, particularly in the USA and in some European countries, which was mainly a response to strong advocacy. However, even in these high-income countries, implementation has spread slowly. Across the low-income countries, there is great variation with regard to the level of access persons with disabilities enjoy. But even though the majority of these countries now have disability policies in place that reflect the adoption of major instruments such as the UN 1982 World Program of Action Concerning Disabled Persons (WPA) and the 1993 Standard Rules on the Equalisation of Opportunities for Persons with Disabilities (Standard Rules) and the UNCRPD (2008), implementation of access to the built environment has generally not been given significant priority in the field of construction in most low-income countries.

The differences in the social and political environment across countries make different approaches to implementation processes necessary. Furthermore, experience has shown that a combination of different approaches relating to the individual stages of development proved to be the most efficient strategy.

Below are some of the elements mentioned that have been successfully employed in many countries.

Advocacy and public awareness raising

In many societies, certain superstitions, fears and misconceptions about disability prevail resulting in negative attitudes towards or avoidance of contact with persons with disabilities and sometimes also their families. Consequently, a first step towards greater access to the built up environment and hence greater social inclusion of persons with disabilities is the change of such attitudes and perceptions within society. The level of public responsibility and control can be effectively increased through public awareness.

Persons with disabilities and national and international organisations of persons with disabilities (DPOs) play a major role in promoting awareness on their specific needs. As they know their own needs best, they are also the best to tell policy makers, planners and implementing agencies about circumstances which create barriers for them.

Effective advocacy targets a variety of audiences starting from the local communities, other persons with disabilities and reaching out to professionals (architects, planners), key government officials and political decision makers, the mass media and the public at large.



Effective advocacy involves many different strategies, which may include the provision of information material for the public and persons with disabilities, face-to-face meetings with key persons, the involvement of the mass media, the conduction of "access-audits" (see Chapter 8.3 in the Appendix) for buildings or the launching of national access awareness campaigns. Another crucial element may also be the provision of training and education on architectural accessibility, as it is often the case in low-income countries that planning and decision making rely on authorities, which have not been exposed to accessibility issues before.

Formulation of policies and legislations

Most countries have already formulated their objectives and standards on the inclusion of persons with disabilities in a political framework. Policies are statements about the objectives and goals and strategies by which they are to be achieved. They can be issued as policy documents, white papers or as part of a formal legislation. Legislation however, reaches further than policies specifying in details what various stakeholders can and cannot do to achieve the goals of a policy involving a variety of legal instruments. Hence, the **right of persons with disabilities to access** the built up environment can most effectively be ensured by enacting an access legislation supported by a comprehensive access policy.

The key steps in formulating and applying such access legislation include the following elements:

- **Pre-formulation:** The mobilisation of grass root support and support of key persons and organisations such as Disabled peoples' Organisations (DPOs) or political parties.
- **Formulation:** The drafting of access policy provisions and access legislations and obtaining public feedback on the draft (which can e.g. involve the set-up of an advisory committee).
- **Implementation:** The application of access policy provisions and legislations.
- **Enforcement** of the new access policy provisions and legislations employing certain enforcement mechanisms such as imposing penalties in the case of non-compliance or the provision of incentives.
- **Monitoring:** The monitoring of the enforcement will involve feedback from persons with disabilities and the public.

Local Context:

However, major obstacles remain to translate such instruments into the provision of accessible buildings and facilities. Key impediment to providing inclusive buildings in low-income countries is mainly inadequate monitoring and enforcement of compliance with existing accessibility legislations. Often, the legislation has not been matched by adequately detailed regulatory frameworks and therefore, response on the ground is very limited. Moreover, the lack of financial resources imposes a barrier towards the implementation of



accessibility legislations. Governments often find it difficult to allocate funding for accessibility requirements and the private sector may not find sufficient incentives to implement provisions for persons with disabilities.

Securing of financial resources and appropriate solutions

For the implementation of improved access to the built environment for persons with disabilities, sources of funding need to be identified. As already described above, the availability of funds represents a major barrier in implementing access to the built environment. Hence, implementation should focus on cost-effective measures first:

It is clear that costs for providing accessible buildings and facilities are much less when these features are already incorporated in the design phase instead of being retro fitted to existing buildings (according to a rough estimate, the additional costs for providing full access is about 1% - 2% of the total construction costs when incorporated into the construction).

In many situations low cost improvements such as ramps or large letters can already bring disproportionate benefits to persons with disabilities. However, most interesting to funders and financiers might be the fact, that most of the interventions needed bring benefit to all building users, creating a win-win opportunity.

Participation of persons with disabilities

The definition of the general framework of needs to be fulfilled by the built up environment is crucial to the successful implementation of its accessibility.

Hence, the importance of a participatory process is to define the requirements and features to be incorporated into the design, in which persons with disabilities can express their own needs.

After the completion of a building or facility, regarding accessibility features information should be provided to potential users with disabilities via local Disability Organisations, radio, leaflets, newspapers, etc. to ensure they know about the improvements and hence potential usage.

Planning and implementation of architectural access strategies

Strategies and plans for the implementation of access to the built up environment have to be developed aiming at the maximum effectiveness but also considering restrained resources. The struggle of many countries towards visible implementation despite having legislative frameworks on accessibility in place highlights the need for proper implementation strategies and plans. The provision of an accessible building involves the following stages:



- Pre-planning phase
- Planning and design phase
- Approval or permission
- Construction and on site monitoring
- Maintenance

It is clear that these stages involve a number of stakeholders from architects to governmental authorities. Crucial for the successful implementation is that awareness on the need for accessibility is guaranteed throughout the whole process and amongst all stakeholders. This involves a high level of coordination and monitoring for which appropriate mechanisms have to be identified.

Generally, **two** basic strategies can be applied which ideally complement each other.

- 1) The inclusion of accessibility standards in the construction of all new buildings and facilities, which guarantees the full consideration of disability issues already in the construction phase and involves significantly lower costs.
- 2) The retrofitting of already completed buildings and facilities, which involves considerably higher costs. Useful is the identification of key buildings within an area or community such as a highly frequented facility (e.g. a hospital) to maximise the benefit achieved for the investment. Such key buildings can be improved incrementally, starting with one priority area such as the entrance (the conduction of an access audit can be helpful for the priority setting; see Annex 8.3) and extending it according to resources and experience.

South-to-south cooperation

Applying "western" standards and solutions to deliver access to the built environment is not always realistic to low-income countries. Hence, the cooperation between different low-income countries in achieving architectural accessibility can be particularly useful as they face similar problems and conditions regarding disability and can benefit from sharing experiences and lessons learned.

1.4. Architectural Accessibility in Post-Disaster Situation

Persons with disabilities represent one of the most vulnerable and neglected groups in post-disaster situations as their particular needs are often not addressed in the response and rehabilitation efforts. Whilst it is difficult to glean elements of hope in the aftermath of such tragic events, it is of utmost importance for organisations and authorities involved in the planning and implementation of rehabilitation activities to make use of the unprecedented opportunities in their response to include persons with disabilities and their needs to ensure a sustainable inclusive development approach.



A crucial area for the mainstreaming of disability issues into disaster rehabilitation efforts is the reconstruction of destroyed infrastructure: The employment of accessible and inclusive building designs in reconstruction efforts will permit persons with disabilities equal access to the facilities in future, increasing the opportunities for children and adults with disabilities to participate in all social, political and economic aspects of community life. Moreover, the incorporation of accessibility features at the outset involves only minimal costs (approximately 1% - 2% of the total building costs) compared to the retrofitting of already existing buildings, which is far more costly and time consuming.

Moreover, in many low income countries, policies regarding the inclusion of persons with disabilities and more particular on their right to access to the built environment already exist but their implementation was not paid sufficient attention to so far. Hence, particularly such periods of rapid construction in countries that suffered from conflict or natural disasters offer the chance to implement or enforce existing policies or legislations on access to the built up environment.

To ensure the accessibility of the infrastructure to be built in the context of post disaster rehabilitation and reconstruction activities, it is crucial to incorporate the issue of accessibility already in the planning stage. Hence, all decision makers, authorities and organisations involved in the reconstruction should be aware of the need to apply the Design for All approach in their reconstruction activities. In achieving this, it is essential to seek and ensure the active participation of persons with disabilities and local Disabled Peoples' Organisations (DPOs) from the outset of the reconstruction activities onwards, i.e. from the planning stage to the implementation and monitoring phase.

**Good
Practice
Example****Access for all campaign, Sri Lanka**

In the initial aftermath of the Tsunami on December 26, 2004, local NGOs, DPOs, governmental authorities and INGOs came together in Sri Lanka to form the **Access for All campaign** to advocate and promote the inclusion of persons with disabilities, their rights and needs in the mainstream post tsunami rehabilitation and development activities. Members of the initiative are the Disability Organisations Joint Front (DOJF, an umbrella organization of 18 local disability organizations), John Grooms, the CBM, Handicap International, the Spinal Injuries Association, Motivation and MOH authorities. The major short and medium term objective of this campaign is to promote the architectural accessibility in the reconstruction of the destroyed infrastructure including private housing and public buildings such as schools and hospitals. In achieving this goal, a major and very successful media, advocacy and awareness raising campaign was launched which generated great interest and discussion on the subject both in NGOs/INGOs and governmental bodies involved in the reconstruction. Parallel to its advocacy activities, the campaign establishes links to all INGOs/NGOs and governmental bodies involved in reconstruction providing technical advice, resources and support on architectural accessibility both in the planning and implementation phase.

Notes: _____



Anthropometrics and measures of assistive device



2. Anthropometrics and Measures of Assistive Devices

This chapter and the following ones will introduce basic measurement and dimensional indications, based on the accessibility legislation framework of some countries. These indications have been split off in requirements of accessibility and referring directly both to spaces and places and to specific disabilities.

Regardless of dimensional and anthropometrical data, in principle accessible products, services and environments are designed in a respectful, safe, healthy, functional, comprehensible and aesthetic way and shall satisfy the following requirements³:

- No disadvantages to users as a result of inappropriate implementation of the requirements and recommendations which are only used by a few but could disadvantage many
- No discrimination against or stigmatising of users
- Design according to the dual-channel principle (Provision of important information by two sensory channel and usability via an alternative method of handing; example: as well as the visual channel, the tactile (hands and feet) or auditory channel should be used).

Anthropometry is the relative measurement of body dimensions such as stature, sizes of body parts and the space in which the body functions, e.g. reach limits and ranges of joint motion.

In architecture and interior design, anthropometry is the basis for many design requirements including those related to **accessibility**.

The following section presents basic dimensional and anthropometrical data that provide a guideline when designing facilities and buildings in an accessible way. The data provided in this publication is based on typical values found in various countries and where appropriate, allowable ranges are given.

Local Context:

However, anthropometrical data of individuals change during lifetime and also vary between individuals and from one country to another. And so do actual designs and sizes. Therefore, possible designs should be based on locally collected data and recommendations.

2.1. Wheelchair Dimensions

Figure 1 and 2 show some of the typical dimensions of a standard wheelchair. Electric wheelchairs may be larger and cannot be manoeuvred in the same way as manual wheelchairs.

³ Cf. DIN technical report 124 (Products in Design for All), published by: DIN Deutsches Institut für Normung e.V. Berlin 2002

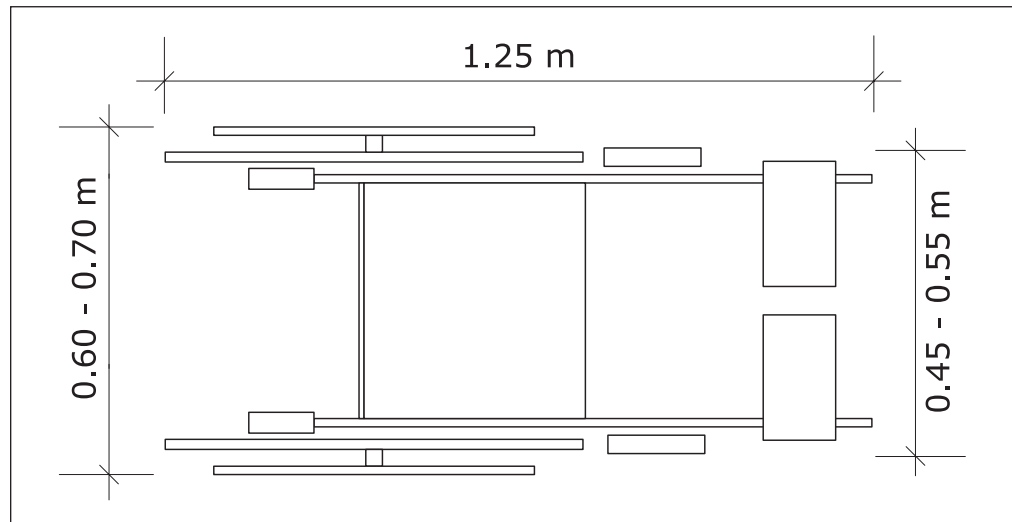

Fig.1 a

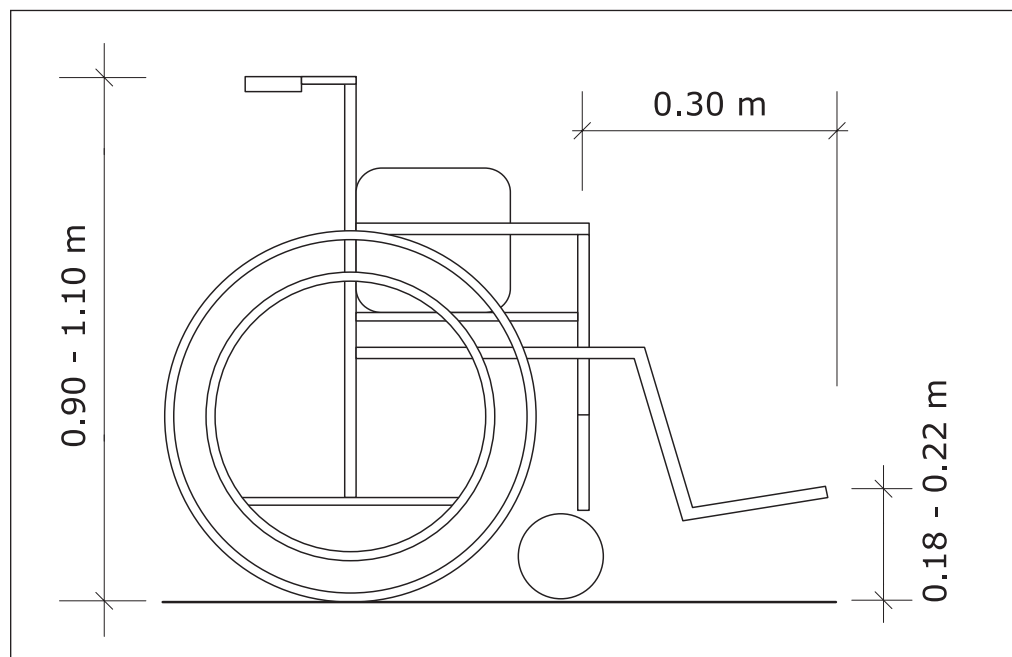

Fig.1 b

Local Context:

Guidelines on the provision of Manual wheelchairs in less resourced setting. Published by: WHO, ISPO, USAID (2008)
 Downloadable: www.who.int/disabilities/publications/technology/wheelchairguidelines/en/index.html

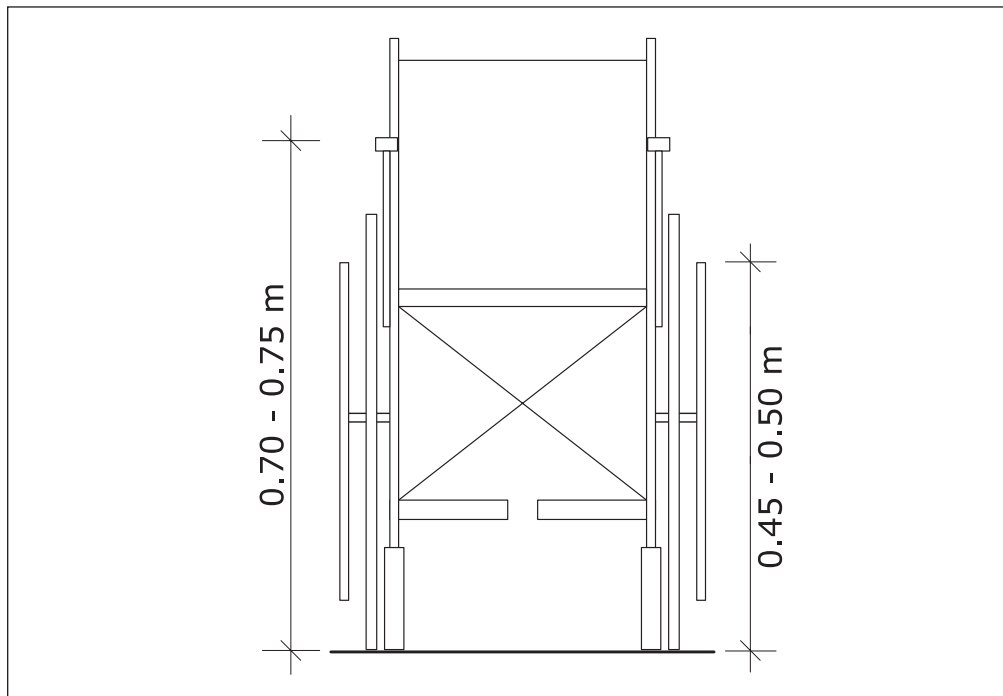

Fig.1 c

Fig. 1 a-c: Dimensions of a standard manual wheelchair

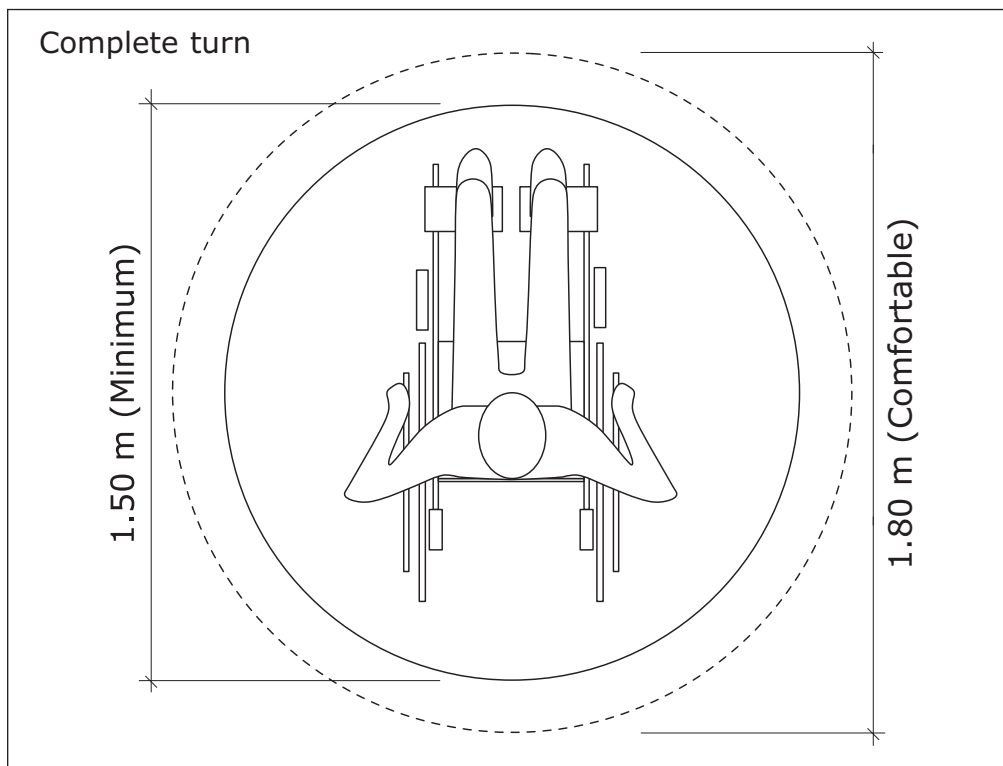

Fig.2 a

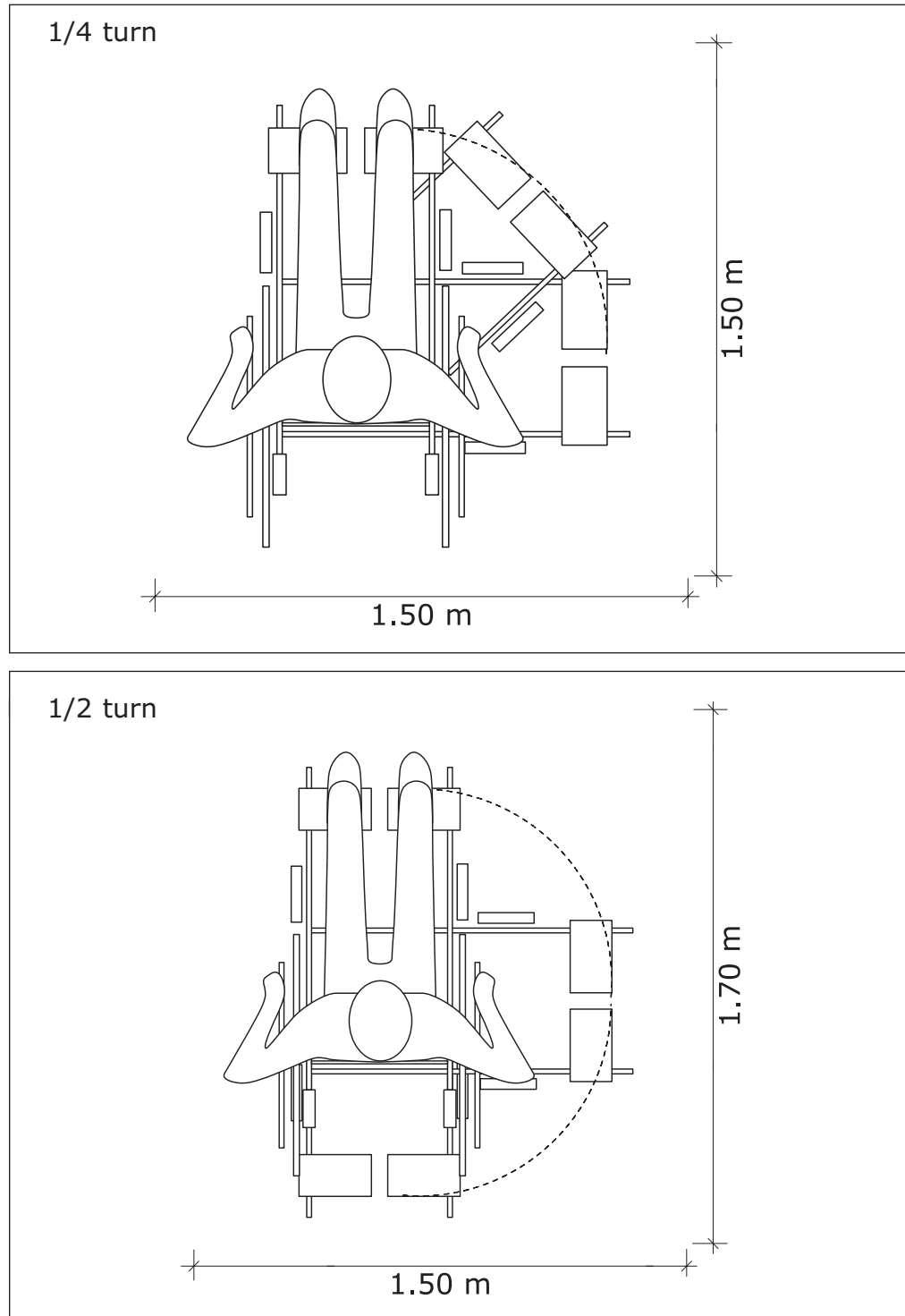

Fig.2 c

Fig. 2 a-c: Wheelchair turning spaces (the encircled figure refers to electric wheelchairs)



2.2. Pathway Dimensions

Figure 3 shows minimum passing spaces for wheelchair users.

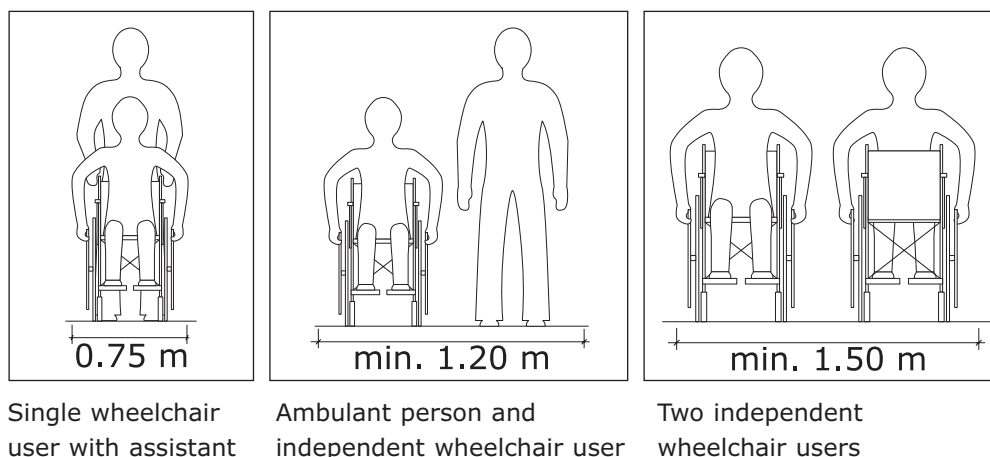

Fig.3: Utilisation spaces for wheelchair users

Figure 4 shows utilisation spaces needed for forward movement when using different mobility aids. Although people who use walking aids can usually manoeuvre through narrow openings, they need wider passageways for comfortable gaits as shown below. Particularly crutch tips, often extending down at a wide angle, can present a hazard in narrow walkways where other pedestrians might not see them.

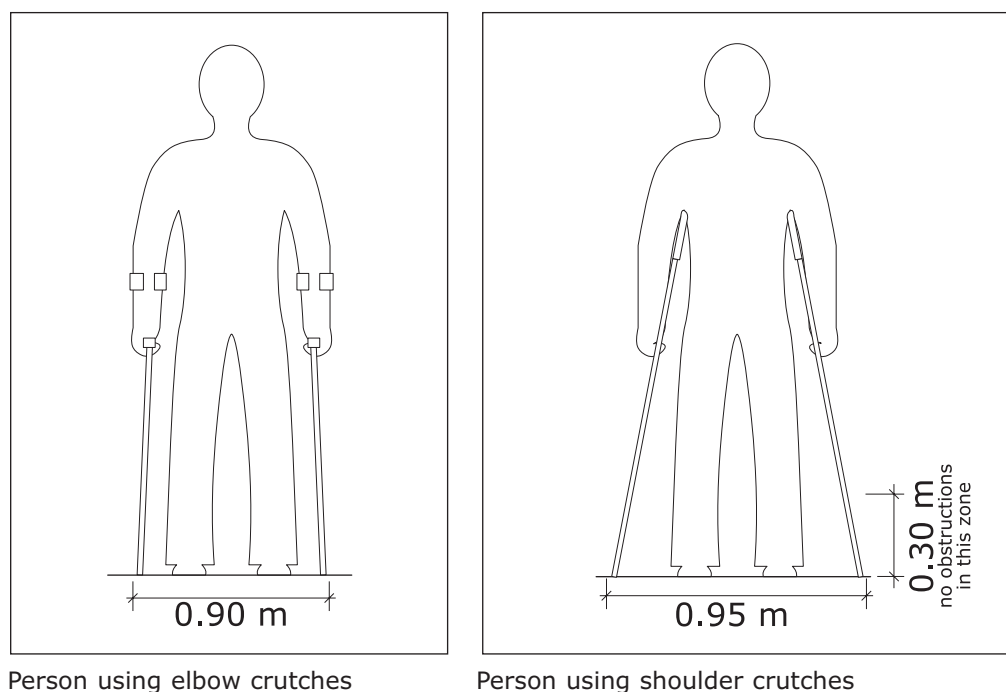
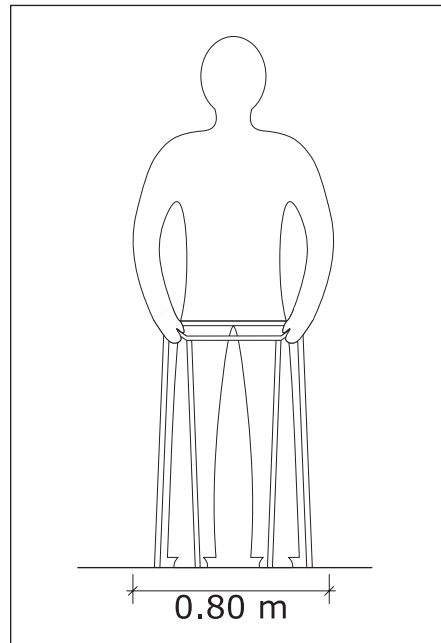
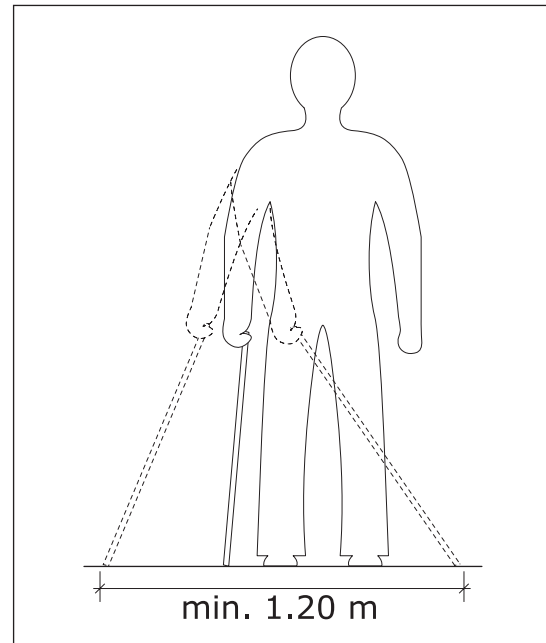

Fig.4 a



Person using a walking frame



Visually impaired person using a long white cane

Fig.4 b

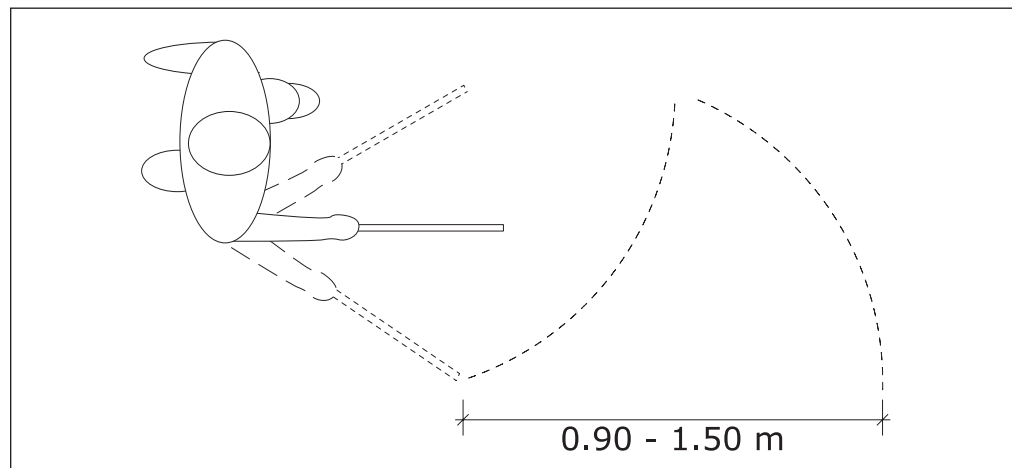

Detectable path dimensions

Fig.4 c

Fig.4 a-c: Utilisation spaces of persons using different mobility aids

2.3. Reaching Zones

The reach of a wheelchair user is constrained by his seated position and the wheels of the chair and the footrest extension limit access to room corners, workbenches or switches.



Figure 5, 6 and 7 present various reach ranges for adult persons and wheelchair users. Figure 8 shows the common reaching zone of wheelchair users and non-wheelchair users.

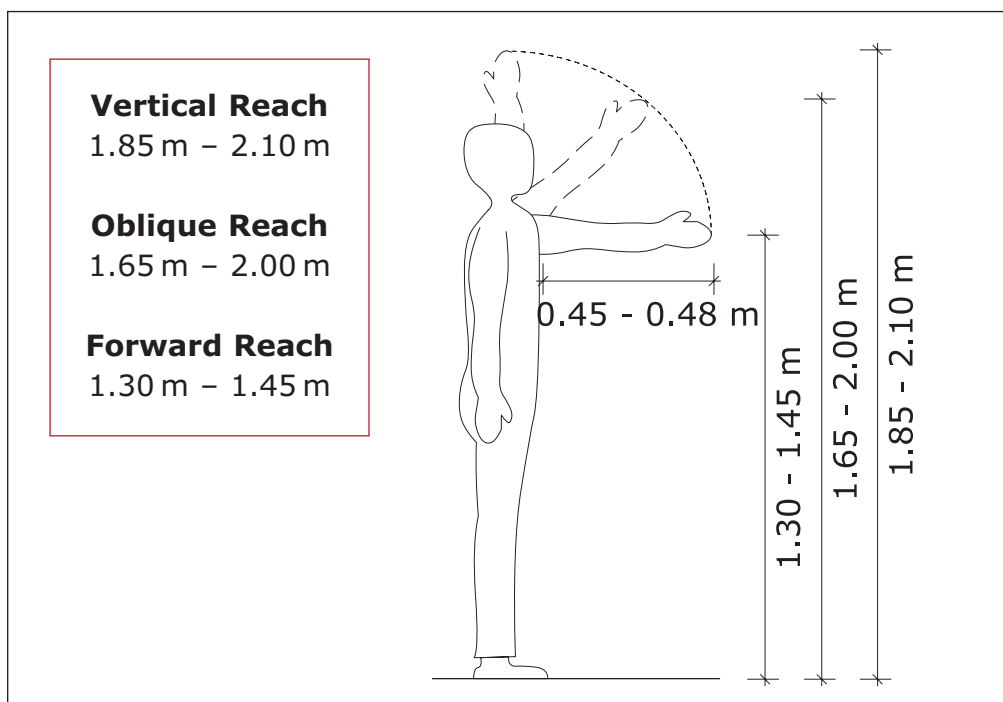

Fig.5: Reaching zones of an adult person

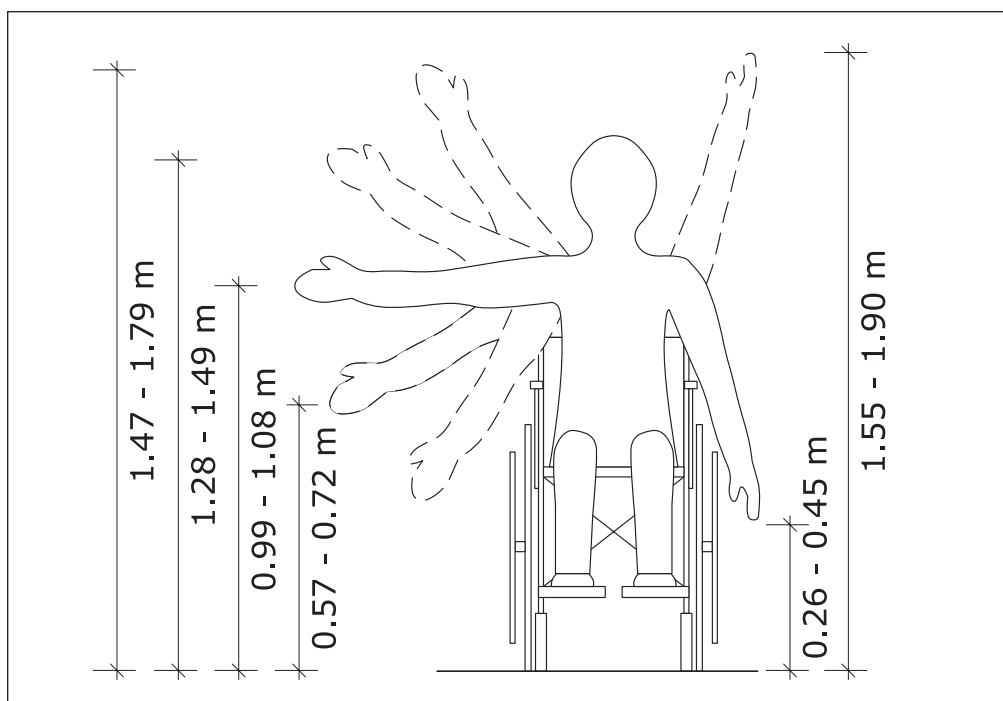

Fig.6: Vertical reaching zones of a wheelchair user with and without obstruction

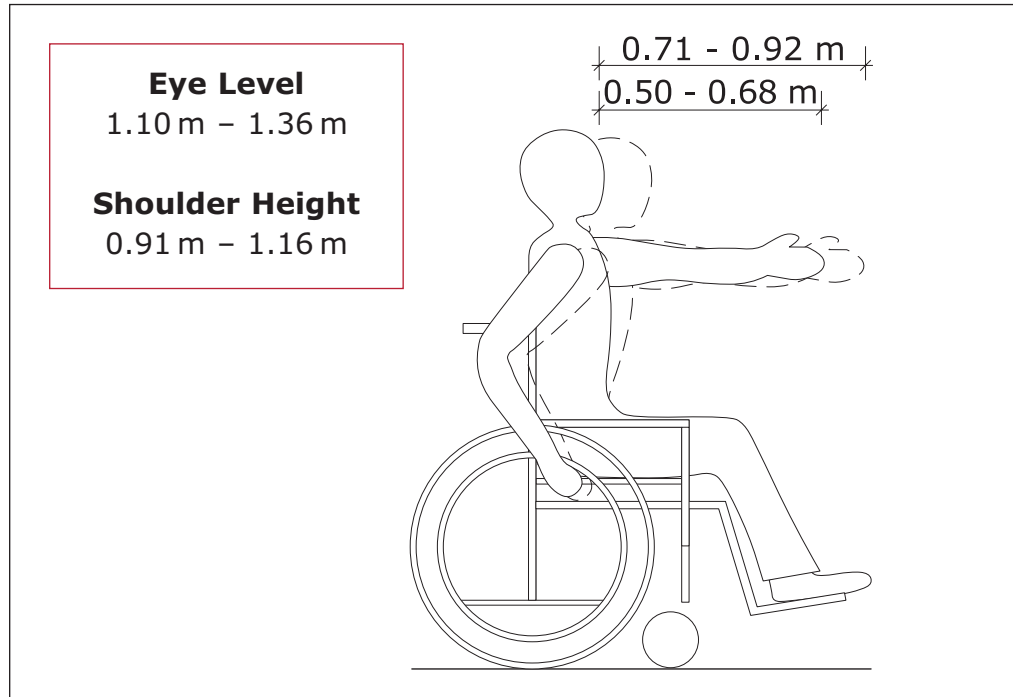

Fig.7: Horizontal forward reach of a wheelchair user with and without obstruction

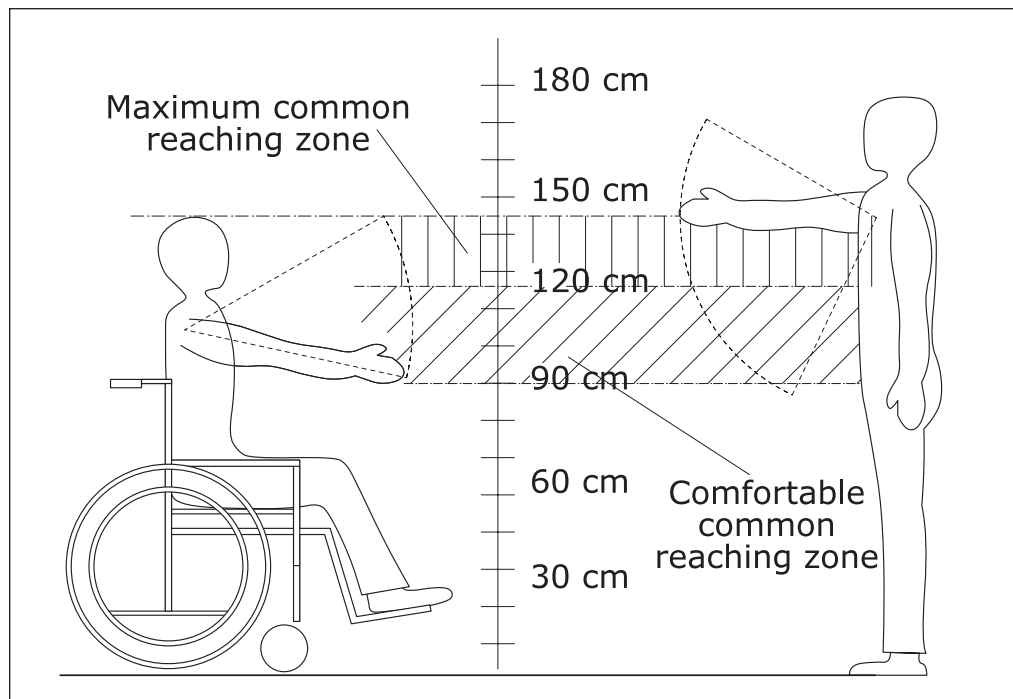

Fig.8: Common reaching zone



Notes: _____



Visual Accessibility



3. Visual Accessibility

The following technical recommendations are shown to highlight some necessary elements and features to fulfil the request of accessibility.

Local Context:

But, regulations and measurements vary greatly from country to country. Therefore, wherever possible, design should be based on locally collected, validated and – if applicable – approved recommendations.

Orientation within the built up environment depends for most people to a great degree on its visual design, particularly on **contrast, light, colour and a continuous usage of visual aids**: for fully sighted people, the visual perception of their environment accounts for up to 90% of the signals relevant for orientation. Partially sighted people are usually less susceptible to contrasts. They rather look for orientation guides and high-contrast objects within the close-up range and therefore, large spaces can impose significant problems to them (Figure 9).

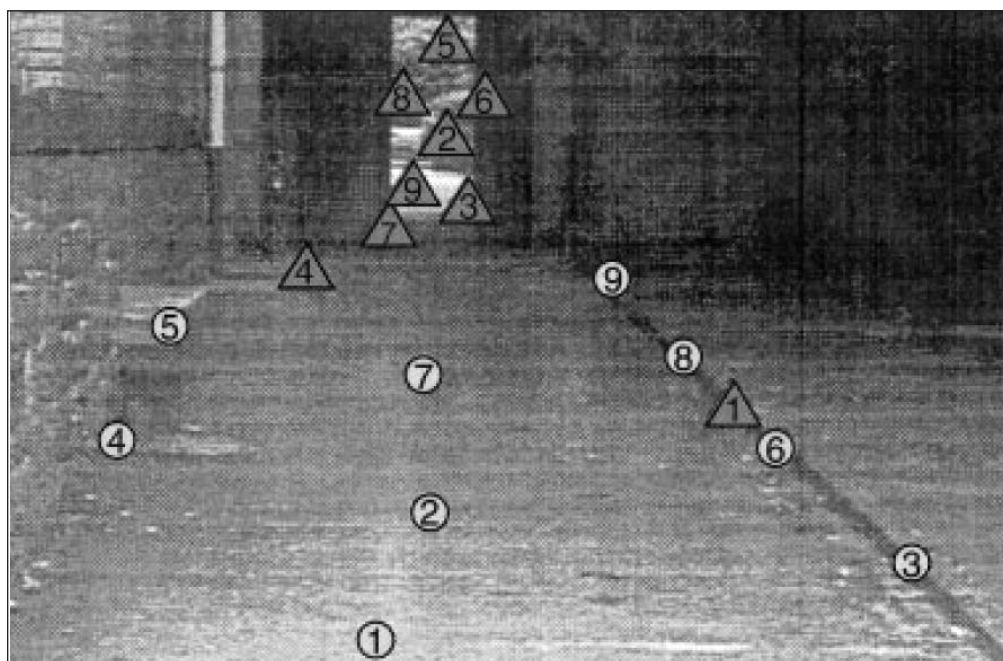

Fig.9: Focus of fully sighted persons (triangles) and visually impaired persons (circles)

Hence, the visual structuring of situations through the professional and systematic arrangement of contrasts, information systems and light is crucial to the orientation and mobility of fully sighted and visually impaired users. Orientation cues such as changes in illumination level, contrasts and unique patterns help particularly visually impaired people to make maximum use of their residual vision and to distinguish pathways and locations.



This section provides principles and functional recommendations for the visual structuring and design of spaces and buildings.

3.1. Use of Colour

Purpose

To create a high contrast environment, which facilitates easy and safe orientation within buildings and facilities.

Design Principles

➤ Colour contrast

Contrasts help people to differentiate their environment and provide important information for their orientation. Crucial to the perception of objects and situations is thereby the **level of contrast**. Often, colours that appear to be very different from each other are tonally very similar and therefore do not provide sufficient contrast (e.g. green and brown).

Tool:

An easy method to determine whether a colour scheme provides high contrast or not is to take a black and white photocopy of it. High contrasts will show up as black/white whereas poor contrasts will show up as grey.

The following website offers a more concise colour contrast check:
<http://snook.ca/technical/colour.contrast/colour.html>

To ensure high contrasts, colour schemes should have at least one or more of the following characteristics:

- High luminance contrasts (e.g. black on white, black on green)
- An achromatic component (e.g. white on blue, green on black)
- Combination of complementary colours (e.g. yellow on blue)
- Utilisation of red only as a dark component (e.g. white on red)

According to these criteria, table 1 shows a range of effective colour schemes to be used. The combinations of red/green and yellow/blue should not be applied, as they will confuse colour-blind persons.



Foreground	Background	or	or	or
White	Achromatic	Purple	Blue	
Black	Achromatic			
Yellow	Achromatic	Purple	(Blue)	Red
Green	Achromatic	Blue		
Blue	Achromatic			

Table 1: Selection of recommended colour contrasts

Contrasts should particularly be applied in the following specific areas:

- In complex areas (e.g. entrance halls, intersections) to provide structure
- Where guidance from and to particular facilities, areas and services is needed (e.g. bathrooms, reception desks etc.)
- For orientation systems and signage (see section 3.3, describes this issue in more details)
- To highlight hazardous areas and objects
- For fittings (e.g. use of different coloured soap dispensers and toilet roll holders, dark toilet seats on white fittings or dark tiles behind white wash hand basins)
- For switches (dark switch and socket plates should be used for light backgrounds or vice versa)
- For access doors (the door or the door frame can be painted in a colour that contrasts with the adjoining wall to facilitate its identification)
- For circulation routes (the use of different colours in floor finish or guiding strips on walls helps to define circulation routes and support signage, Figure 10)

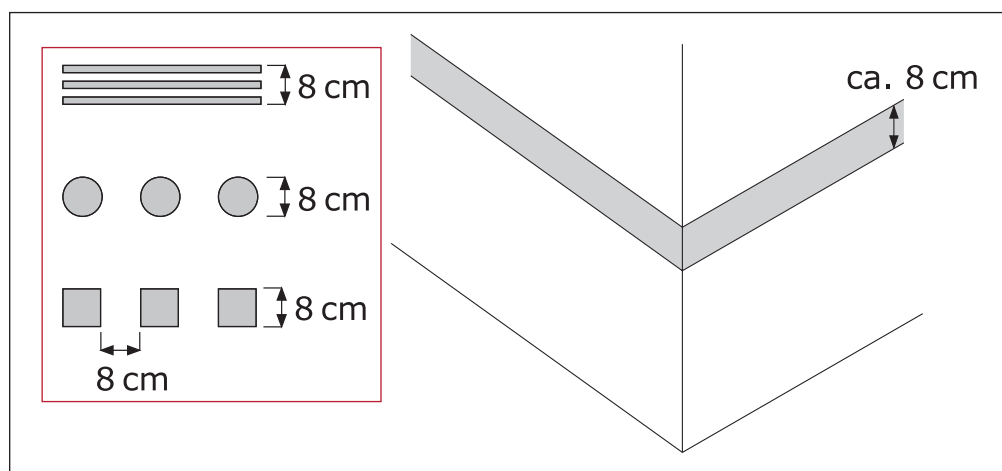

Fig.10: Example of guiding strips on walls within buildings to support signage



3.2. Lighting

Purpose

To create a flexible lighting system that accommodates the various lighting needs of building users, particularly those with visual impairments.

Design Principles

In general, the flexibility of a lighting system depends on its controllability. Hence, dimmer switches should be employed in places where individual control of illumination levels is needed. Multiple lamps in light systems, each governed by a separate switch also enable the adjustment.

Reflection, glare, shadows and large variations in lighting levels always cause visual confusion and hinder orientation, particularly for people with visual impairments.

- **Reflection** can be minimised with the use of non-reflective finishes and glasses.
- **Glare** can be reduced by the careful positioning of luminaries out of the direct line of vision.
- **Glare from daylight** can be avoided by installing adjustable blinds.
- **Shadows** can mask hazards and can be avoided by increasing the level of ambient light.
- Feature lighting, such as down lighters, should be located where they will not cause **shadows** on peoples' faces making lip-reading or identification of the facial expressions difficult (e.g. at receptions).
- **Changes in lighting levels** should always be gradual to enable the adaptation of the eye.

- Secondary functions of lighting should be considered:
 - Lighting can provide directional guidance (e.g. the illumination of a corridor by a series of tubular fittings mounted longitudinally on the ceiling).
 - Lighting can highlight potential hazards (e.g. staircases).
 - Lighting can support / indicate the function of a specific area (e.g. the use of warm light in waiting areas or rest rooms).

3.3. Signage

Purpose

To facilitate orientation within the built up environment through an adequate and continuous usage of orientation aids.



Design Principles

Signage accounts for only a small percentage of the total building costs (ca. 0,1%), but contributes greatly to peoples' orientation and safety within the built up environment. A signage system is particularly important to people with visual and hearing impairments.

➤ Character proportions

The size of letters and symbols depends on the reading distance and the degree of visual impairment of the reader. Table 2 shows typical letter sizes for different maximum reading distances.

Maximum viewing distance	Letter size
30 m	52.0 cm - 104.0 cm
25 m	44.0 cm - 87.0 cm
20 m	35.0 cm - 70.0 cm
15 m	26.0 cm - 52.0 cm
10 m	17.0 cm - 35.0 cm
5 m	9.0 cm - 18.0 cm
2 m	3.5 cm - 7.0 cm
1 m	1.8 cm - 3.5 cm
30 cm	0.5 cm - 1.0 cm
25 cm	0.4 cm - 0.9 cm

Table 2: Recommended letter sizes for signage and visual information

- Best typefaces to use for signs and information are sans serif fonts (e.g. Verdana or Arial). The width-to-height ratio of letters, numbers and symbols on a sign should be between 3:5 and 1:1.
- The character stroke width-to-height ratio should be between 1:5 and 1:10.
- Format and design
 - It is essential that letters and symbols on a sign contrast with the background of the sign to be clearly distinguishable. Table 1 (Page 3-3) shows a range of recommended high contrast colour schemes to be used to achieve maximum readability. The sign-board itself should again contrast with its surrounding.
 - The surface of the sign should be non-reflective and glare free, hence, signs should not be placed behind unprocessed glass.
 - Raised characters or symbols on signs assist persons with visual impairment. Such tactile information should be provided at least beside doors and openings to principal rooms and on key plans. Tactile characters or pictographs on tactile signs shall be raised at least 1 mm and have a minimum height of 15 mm to a maximum of 50 mm.

Note:

Not all blind persons are familiar with Braille!

- Placement of signs
- **Wall-mounted signs**, such as those indicating room numbers, should be placed at a consistent height of between 1.30 m and 1.60 m above floor level.
- **Overhanging signs** should be placed at a minimum clear height of 2.10 m to allow safe passing of blind and visually impaired persons (Figure 11).
- **Fixed signs indicating street names** should be placed at a maximum height of 2.50 m.
- **Maps and information panels** should be placed at a height between 0.90 m and 1.80 m (Figure 12).

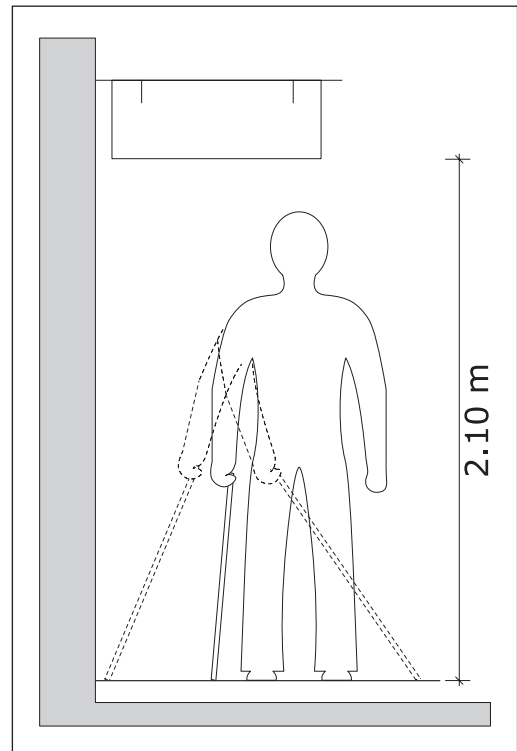

Fig.11: Adequate placement of overhanging signs

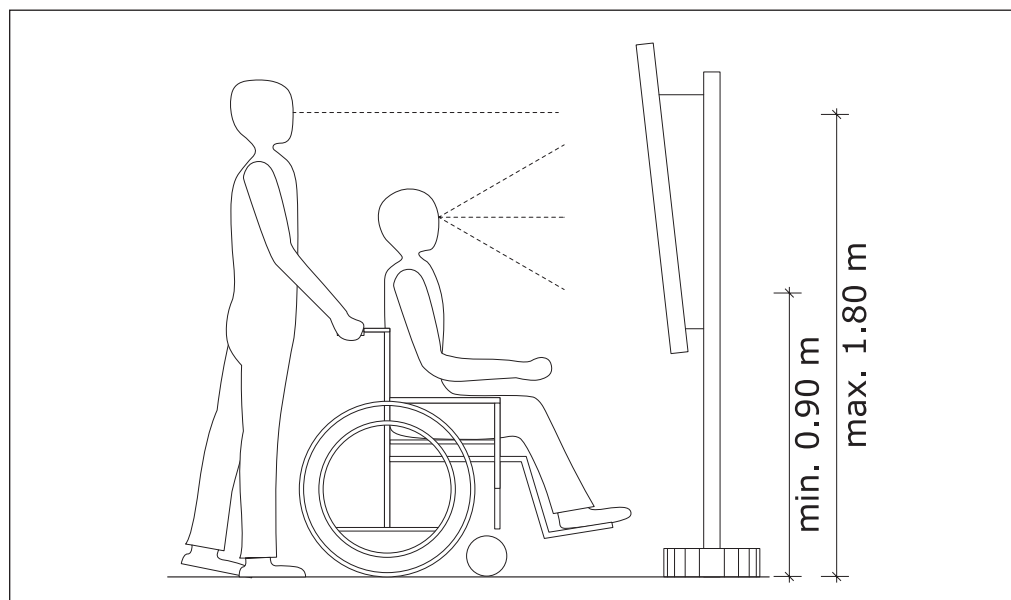

Fig.12: Adequate placement of information panels and maps



➤ Continuity of information

When planning a system of information it is crucial to ensure continuity and consistency to avoid confusion. A continuous information chain should meet the following standards:

- Constancy of destinations
- Acknowledgement of destination
- Continuous application of uniform principles of display and placement within the building
- Continuous usage of uniform designs within an information chain
- Use of identical pictograms and abbreviations within an information chain

➤ International symbol of access (ISA)

The International symbol of access should be used to identify accessible routes, entrances and facilities within a building. In case of completely accessible buildings, the display of one explanatory sign at the principal entrance is sufficient.



The international symbol of access is used worldwide to direct people with various disabilities towards accessible facilities and features. The proportional layout of the symbol shall be in accordance with the shown figure. The colour of the figure should be white on a blue background and the symbolised figure should always face to the right.

It may be used in conjunction with, and adjacent to other internationally recognised signs or directional indications (Figure 13). More universally used access symbols can be found in the appendices.

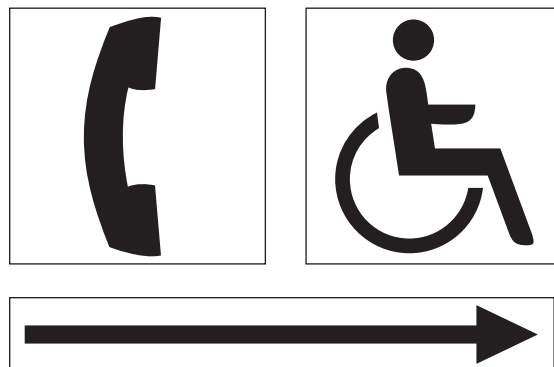

Fig.13: Combination of access symbols with directional signs



Notes: _____



Vertical Accessibility



4. Vertical Accessibility

A whole building is not accessible to all users if changes in levels cannot be overcome or higher floors cannot be reached.

This section deals with technical considerations and adequate solutions how to overcome barriers related to the vertical access to allow all people to make full unassisted use of a building.

While some measures are low-cost such as the construction of ramps, the installation of lifts for instance represents initially a rather expensive option. The costs for maintenance and the availability of spare parts as well as the lack of regularity for the electricity power in some low-income countries might impose difficulties. However, the costs can be minimised by including these access features already in the construction phase of new buildings and the impact can be maximised by installing access features in highly frequented public buildings first.

4.1. Curb Ramps

Purpose

To overcome changes in level on pedestrian paths or cross paths.

Design principles

Curb ramps should be used wherever there is a difference in level or footways cross roads, pavements or any other surface. To ensure the safety of blind people, curb ramps should be located out of the usual line of the pedestrian flow.

- Different types of curb ramps
- The **standard curb ramp** cuts back into the pavement with flared sides providing transition in three directions (Figure 14).
- The **built-up curb ramp** is adjoining to the pavement and has flared edges (Figure 15).

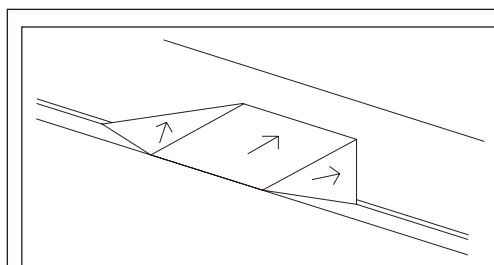

Fig.14: Design of a standard curb ramp

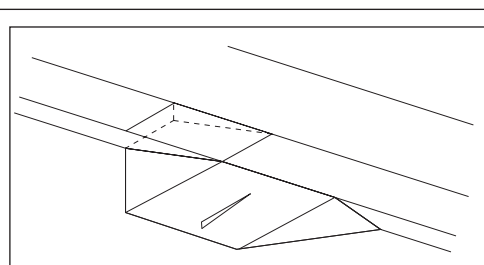

Fig.15: Design of a built-up curb ramp

Note:

In some countries, built-up ramps are only accepted as remedial measures but not on public pathways!

- Dimensions
 - The ramp should have a minimum width of 1.20 m. However, some guidelines recommend only 0.90 m to allow one wheelchair user to just fit.
 - At crossings, the ramp should ideally be as wide as the crossing, but minimum 2.40 m.
 - Curb ramps should not project into the roadway obstructing the traffic.
- Slope
 - The maximum slope should be 8% (1:12) on the direct approach.
 - The maximum slope of the flared sides should also not exceed 8%.
 - Slope changes between curb ramp and pavement should be gradual to prevent the front wheels of a wheelchair getting caught.
- Landing and surface
 - A landing at the top of the curb ramp provides a level area for wheelchair users to change direction after ascending the ramp.
 - The landing should be at least 1.20 m, preferably 1.50 m wide.
 - The bottom of the ramp should flush with the road as already a small difference in level of 6 mm can bring a wheelchair to an abrupt and dangerous end.
 - The surface of curb ramps and flares should be slip-resistant, with a rough texture or pattern and in a contrasting colour to guide people with visual impairments.
 - Adequate drainage at the bottom of the curb ramp should be considered.

Note:

Curb ramps easily become unusable as drivers are not always conscious of the use of curb ramps and park their car in front of it. Clear marking but also an effective and applied policy are therefore important.

4.2. Ramps

Purpose

To provide access to buildings and between different floor levels.

Design principles

Outside, ramps are usually the most practical way to provide wheelchair access between different levels as they are much cheaper to



install and maintain than lifts and will serve almost everybody. When planning indoor ramps, one has to consider that they take up a lot of space.

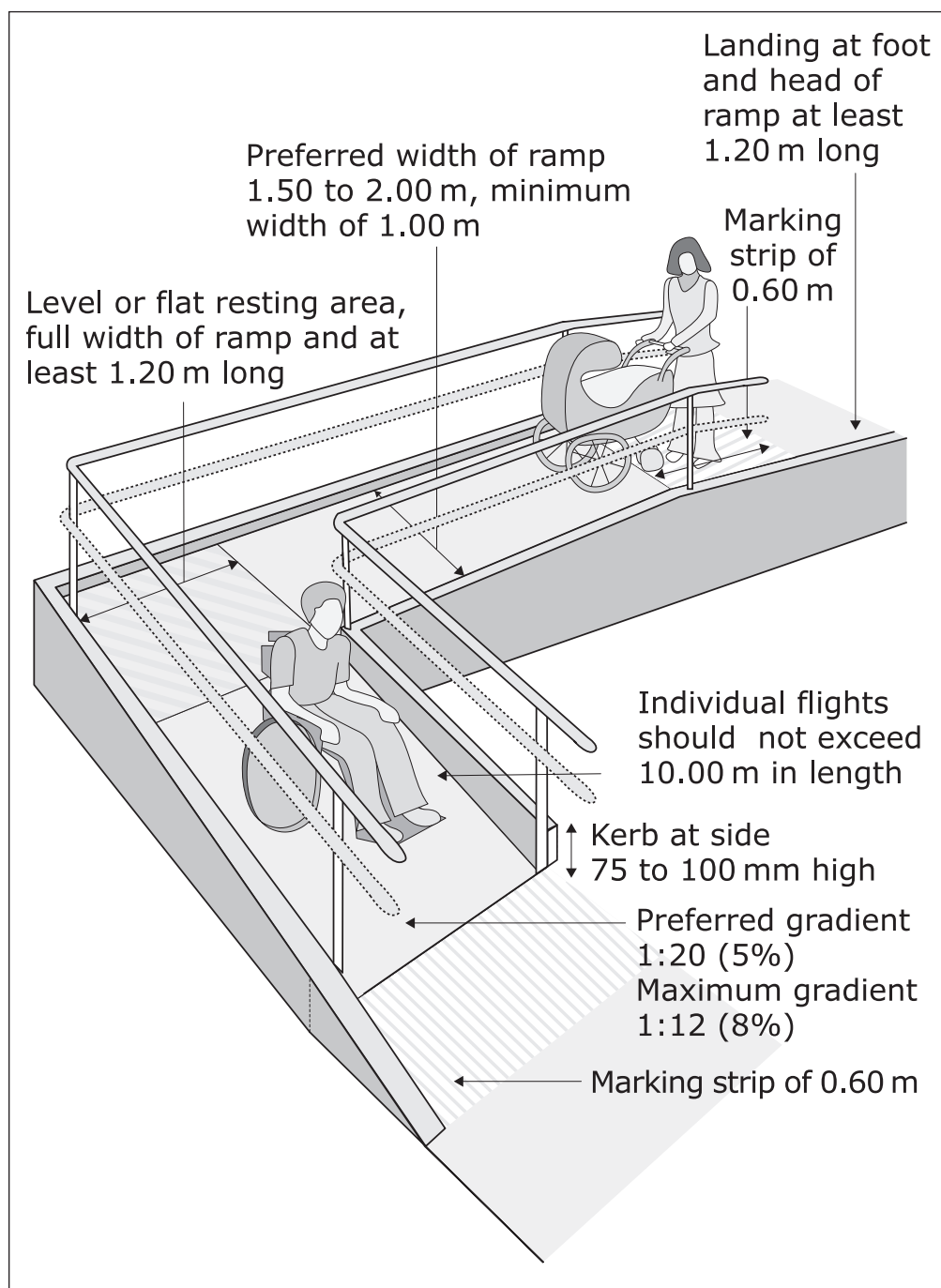

Fig.16: Layout and dimensions of a ramp

Note:

At least one entrance to a public building should always be accessible, preferably the principal entrance. If stairs hinder the access in already existing buildings, at least one ramp has to be provided to ensure access to the building for wheelchair users!



➤ Ramp configuration

There are three design options:

- Straight run
- 90 turn
- Switch back or 180 turn

Note:

Curved or circular ramps are not recommended!

➤ Slope

Having the correct slope is crucial as an overly steep slope can render a ramp too dangerous and inaccessible for an independent wheelchair user (Figure 17).

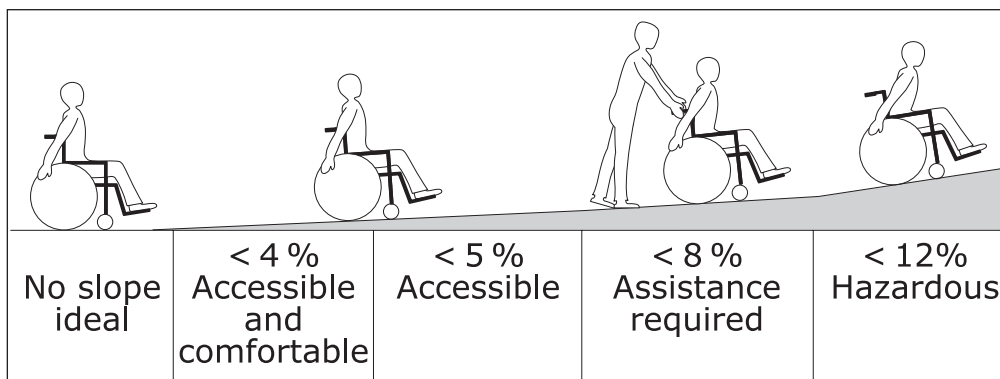

Fig.17: Illustration of different slopes

- The preferred slope of ramps is 5% (1:20) and the maximum acceptable slope is 8% (1:12).
- The maximum vertical slope should not exceed 2%, but preferably there should not be a vertical slope at all.

➤ Landings

The steeper the slope, the shorter the distance that wheelchair users can cover without resting. Therefore, landings should be provided for resting, manoeuvring and avoiding excessive speed. Table 3 shows maximum lengths of ramps for different slopes.

Each landing should have a minimum length of 1.20 m and a width at least equal to that of the ramp.



Slope of ramp	Maximum length	Recommended use
10% (1:10)	Less than 1 metre	Very short distances only
8% (1:12)	2 metres	Maximum slope for general use
5% (1:20)	Up to 10 metres	Preferred slope

Table 3: Recommended slopes and lengths of ramps

- Landings should be provided
 - at least every 10 metres depending on the length of the ramp (Table 3)
 - at every change of direction
 - at the top and bottom of every ramp
- Width
 - The width of a ramp can vary according to use, configuration and slope.
 - The minimum width of a ramp is 0.90 m; the preferred width particularly for public buildings is 1.50 m to 2 m.

Note:

In case of residential housing or restricted space, a ramp width of 0.90 m is sufficient!

- Handrails
 - Handrails should be provided on both sides and along the full length of ramps.
 - The handrails should extend for a distance of minimum 30 cm at the top and bottom of ramps.
 - For ramps wider than 3 m, an intermediate handrail could be installed.
- Surface and tactile markings
 - The surface material should be hard, slip-resistant and easy to maintain (carpets should be avoided).
 - A colour contrasting textural marking strip with a minimum width of 0.60 m should be placed at the top and bottom of the ramp to alert people with visual impairments as to the location of the ramp.
 - Adequate drainage should be ensured to avoid the accumulation of water.
 - The edges of the ramp should be protected by a solid raised curb at least 75 mm to 100 mm high.



4.3. Lifts

Purpose

To provide well-dimensioned and convenient lifts to allow free vertical access between different floors.

Design principles

A carefully designed lift contributes greatly to the accessibility of a building, particularly for people with mobility problems and wheelchair users. While lifts are an expensive option, the provision of platform lifts or stairway lifts for people with mobility problems may be an alternative if it would be unfeasible to install a lift or only splitlevels have to be overcome. However, when there is a substantial change in level or more floors and the building is highly frequented, the costs are justified.

An accessible lift should serve all floors and its location should be clearly indicated and recognisable. The arrival at each floor should be indicated both by optical and acoustic means to alert passengers with visual and hearing impairments.

➤ Lift dimensions

- This publication recommends minimum internal dimensions of 1.40 m x 1.60 m allowing access for one person using a wheelchair and turning a full circle, or two people using a wheelchair side by side.
- The minimum internal lift dimensions are 1 m x 1.30 m and allow access for one wheelchair user alone (Figure 18).
- The clear opening width of the doors should be a minimum of 0.80 m, preferably 0.85 m.

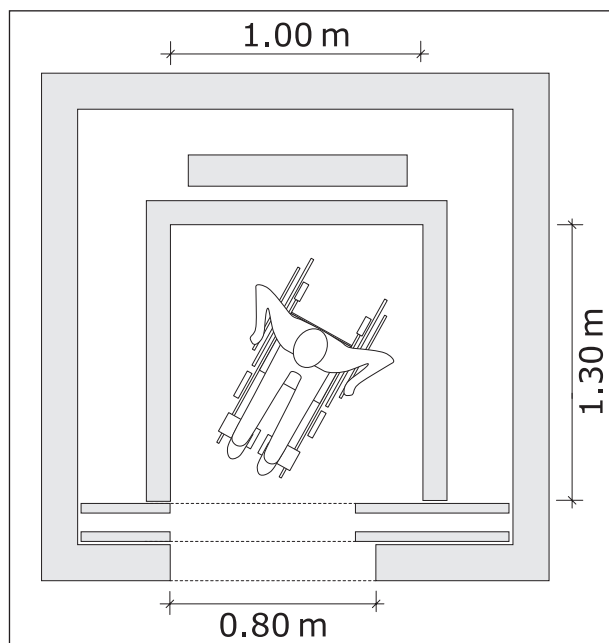

Fig.18: Dimensions of a lift cabin



➤ Lift cabin

- Handrails should be installed mounted 0.80 m to 0.85 m from the floor.
- A mirror placed at a height of 0.40 m up to 1.60 m in opposite of the door provides an important orientation aid for wheelchair users.
- A tip-up seat inside the cabin should be provided for people with mobility problems.
- The light barrier should be placed at a height of 0.50 m as lower light barriers sometimes do not react because of the spokes of wheelchairs.
- The internal light should provide a level of illumination of minimum 100 lux. Spotlights and down lighters should be avoided.

➤ Control panels

- The control panel should be positioned on the flank wall rather than front wall to facilitate access. In larger lifts, control panels on both flank walls should be installed.
- For ease of reach, the control panel should be located within the range of 0.90 m to 1.20 m above floor finish.
- The control buttons should contrast with their surroundings (ideally illuminated) and not be touch-sensitive.
- The numerals should be embossed to be easy identifiable by touch, particularly the alarm button. It is desirable to repeat the legend in Braille.

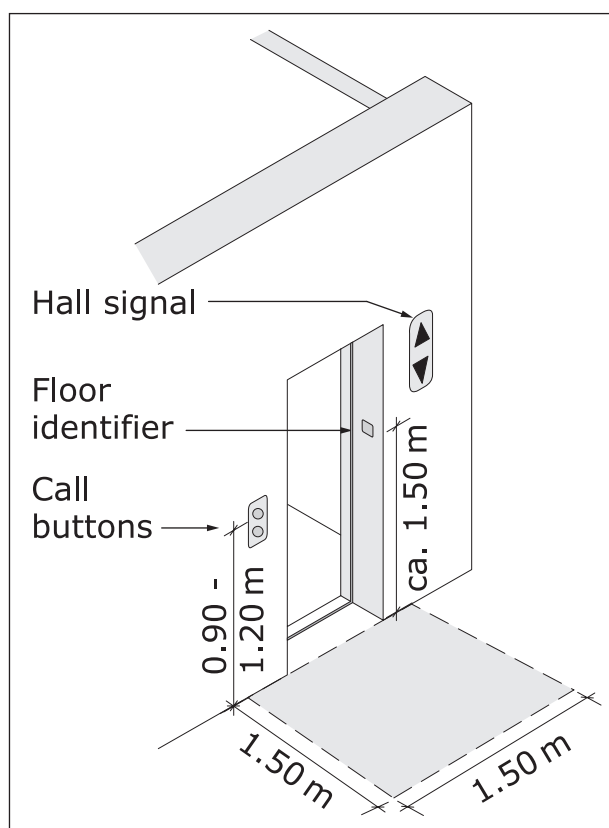

Fig.19: Design of the area in front of the lift doors

➤ Operating controls outside the lift (Figure 19)

- The call buttons should be mounted 0.90 m to 1.20 m from the floor.
- Tactile embossed numerals should be placed on both sides of the door to help a single blind passenger to identify the floor reached.
- The lift hall signal should be located at an approximate height of 1.80 m.



- A clear landing area of minimum 1.50 m x 1.50 m in front of the lift doors should be provided.
- Door re-opening mechanism
- The door-opening interval should be at least five seconds to allow convenient exit for wheelchair users.
- Re-opening activators should be provided.

In case of adjacent lifts, an audible distinction can be useful: For example, using a female voice recorded message in one lift and a male recorded message in the other.

4.4. Stairs

Purpose

To provide safe staircases for all users, particularly those with visual impairments and mobility problems.

Design principles

Generally, it is desirable to have both a ramp and staircases, especially if the ramp is longer than 9 m as many people prefer climbing a shorter staircase than a longer ramp. However, if there is not enough space for both, a ramp should be provided to ensure accessibility for wheelchair users. The careful design of steps and stairs is particularly important for the safety of people with visual impairments and mobility problems (Figure 20).

- Steps
 - All steps in one flight should be uniform.
 - Steps should be 15 cm to 18 cm high and not less than 28 cm deep. Open riser stair cases should not be used as they pose a trip hazard.
 - The nosing should be rounded and not project more than 40 mm.
 - Noses should be provided with permanent colour contrasts to facilitate ease of use for people with visual impairments.
 - The stair covering should be slip-resistant, firmly fixed and easy to maintain.
 - At least every 15 steps, landings should be provided to assist people who cannot manage long staircases. The landing should be at least 1.20 m long.

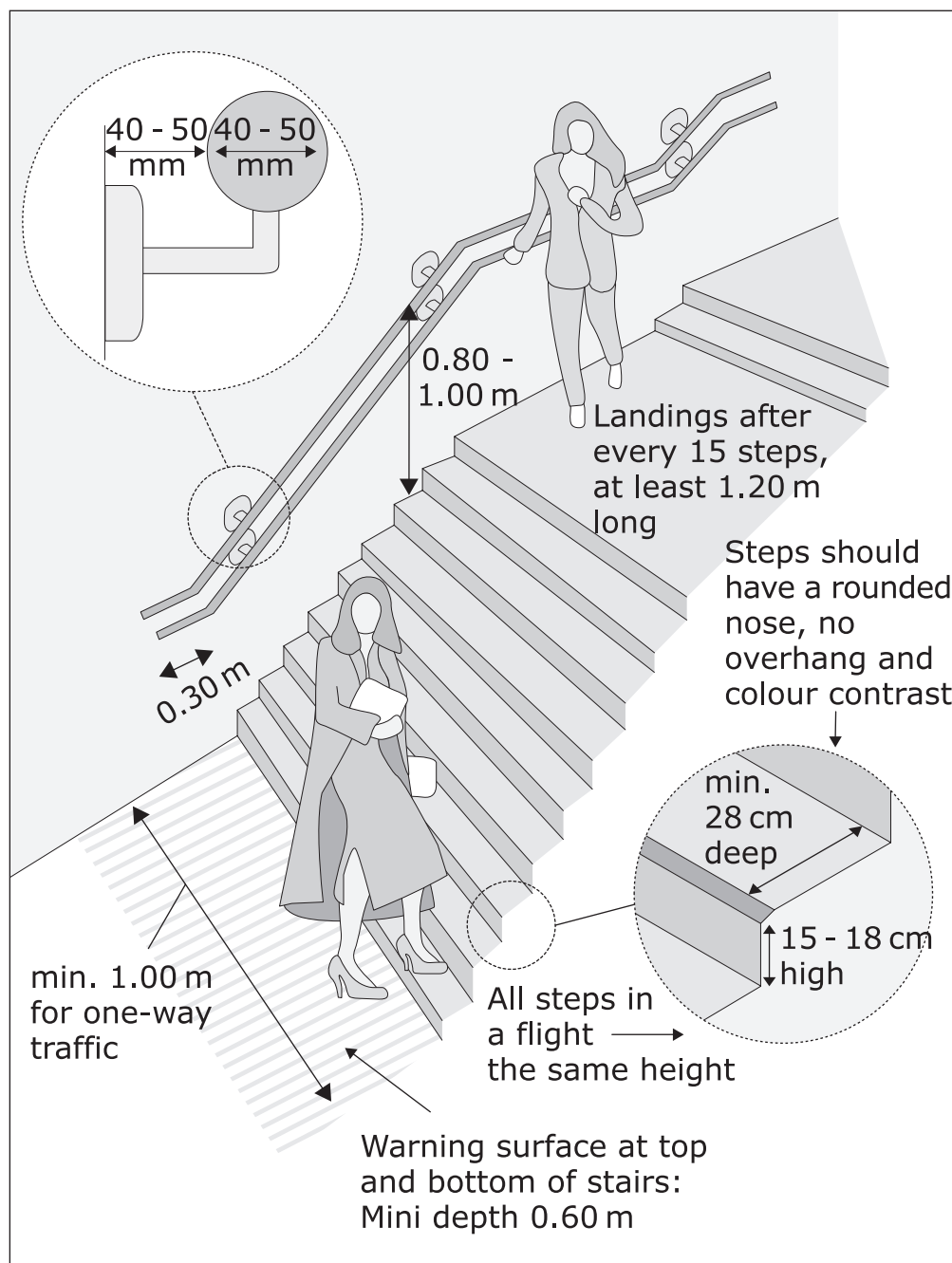

Fig.20: Dimensions of steps and stairs

- Width
 - The clear width of stairways is at least 1 m whereas 1.50 m allows for easy two-way traffic.
- Handrails
 - Handrails should be provided on both sides of the flight and each side of any landings.
 - In case of wider stairs, intermediate handrails should be installed.



- The handrail should be positioned between 0.80 m and 1 m above floor finish.
- The handrails must extend a minimum of 0.30 m beyond the top and bottom steps, turning to the wall.
- The handrails should be supported on brackets, which do not obstruct continuous hand contact with the handrail.
- Tactile marking
 - This publication highly recommends the provision of tactile warning strips **at the top and bottom** of the stairs and **at intermediate landings** to alert people with visual impairments and blind people as to the location of the stairs.
 - The textural marking strip should be at least 0.60 m deep extending over the full width of the stairs.
 - To provide orientation for people with low vision, the marking strip should have a colour contrasting the surrounding surface.
- Lighting
 - Staircases should be well illuminated during day and night when in use (level of illumination preferably between 150 and 200 lux).
 - The lighting in staircases should create contrast between treads and risers while providing a uniform overall level of illumination.

Note:

The underside of freestanding stairs can present a hazard particularly to people with visual impairments (Figure 21). Where the clear height is less than 2.10 m, handrails or barriers should be installed for protection.

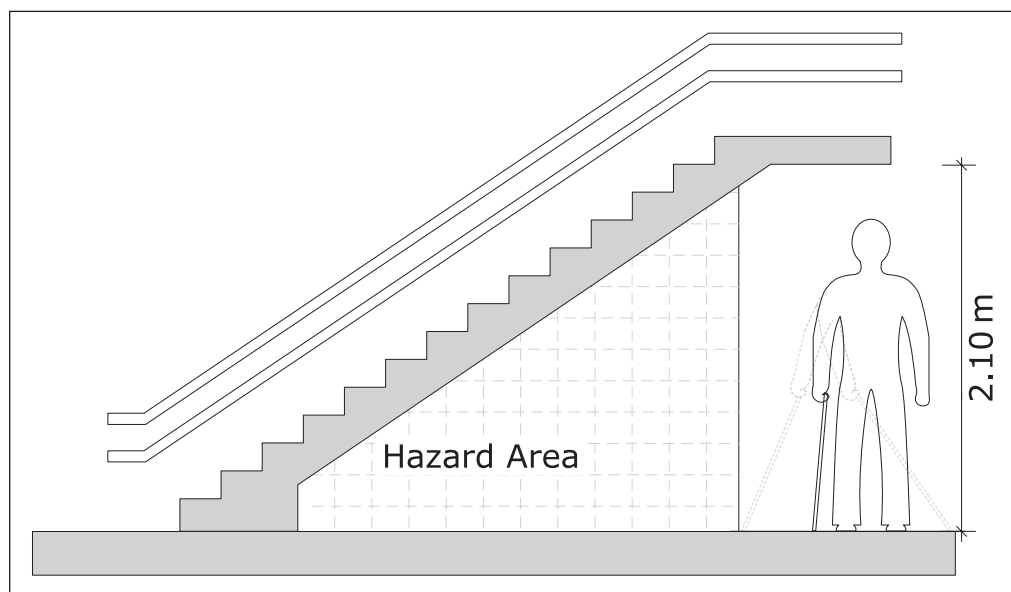

Fig.21: Hazardous area under freestanding stairways



Notes: _____





Horizontal Accessibility



5. Horizontal Accessibility

Seemingly small things such as lack of railings, high thresholds, narrow doors or long corridors can already present huge obstacles that may cause a significant degree of extra stress and effort. Because of such barriers prevalent in the horizontal circulation paths, many people particularly those with disabilities need assistance of an escort or other passengers when moving around or cannot access certain facilities at all. Moreover, the lack of accessible facilities such as toilets may restrain some persons with disabilities from using a building in the first place.

The following section aims to provide layout and design recommendations as well as technical solutions on how to ensure the horizontal accessibility to all users within a building.

Local Context:

However, regulations and measurements vary greatly from country to country. Therefore, wherever possible, designs should be based on locally collected and verified recommendations.

5.1. Doors

Purpose

To facilitate the easy passage through doors, particularly for wheelchair users and people using other mobility aids.

Design principles

Accessible doors should be designed in such way as to permit operation by one person in a single motion.

Accessible doors should have the following features (Figure 22):

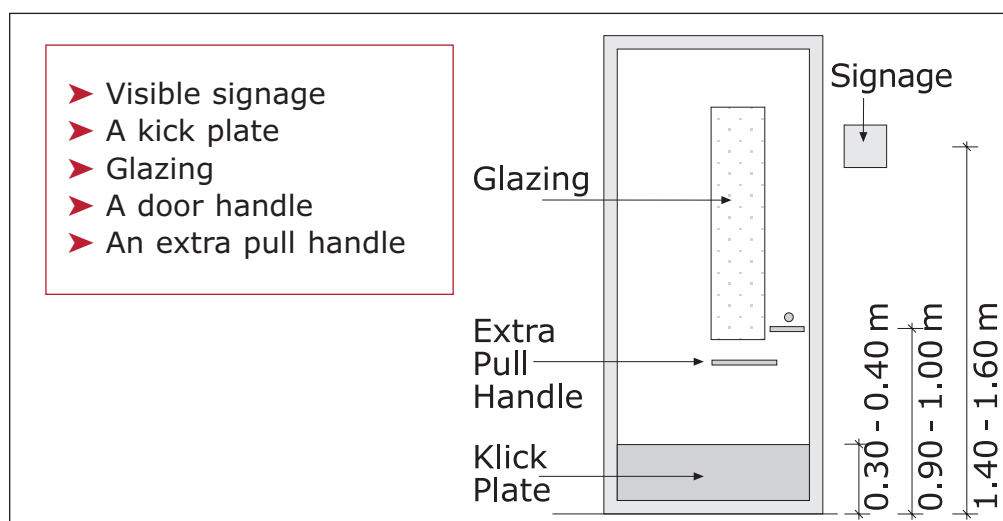

Fig.22: Features of an accessible door



- The **signage** indicating the function or the room number, incorporating international symbols should be located at eye level, between 1.40 m and 1.60 m.
- To ensure **visibility of signage** even when doors are open, the signage should be placed on doorframes or adjoining walls, not on doors themselves.
- To protect the finish on the lower part of doors, **kick plates** should be installed between 0.30 m and 0.40 m in height (this is particularly important when doors are glazed).
- Low **windows** allow users to see oncoming traffic. The bottom edge of the window should not be higher than 1m from floor level. Completely glazed doors should be made visible by use of a coloured band or marking strip at a height between 1.40m and 1.60m.
- All **door furniture** such as handles and pulls should be easy to grasp with one hand. Round knobs are not recommended. The door handles should be positioned between 0.90 m and 1.20 m above floor.
- To facilitate closing of doors particularly for wheelchair users, doors should be fitted with an extra **pull handle** mounted between 0.90 m and 1.20 m from the floor.

Note:

A low cost alternative to an extra pull handle, particularly in private housing settings, may be a long string that is fixed to the door handle to enable wheelchair users to close the door easily!

- Door dimensions (Fig. 23)
- For exterior doors, a minimum width of 0.90 m is recommended.
- For interior doors, a minimum width of 0.80 m is recommended.
- A clear height of 2.10 m to 2.20 m is recommended for all doors.

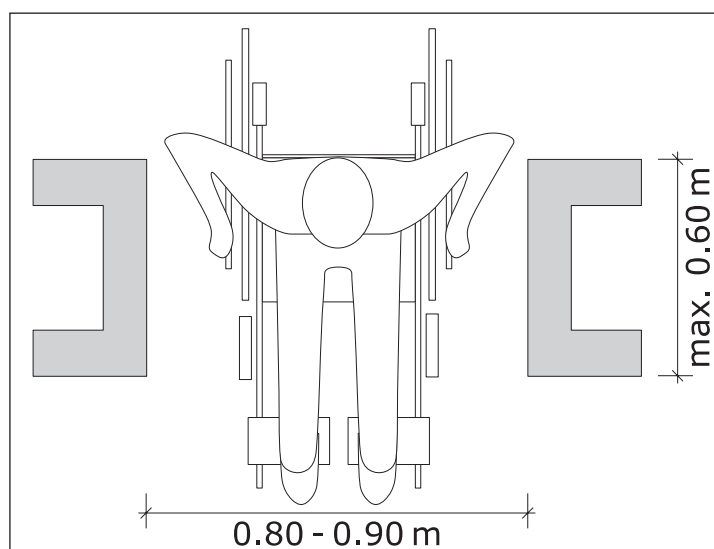

Fig.23: Recommended door dimensions



➤ Manual doors

- In case of double doors, at least one leaf should be 0.80 m wide so that wheelchair users do not have to open both leaves (Figure 24).
- The required door opening force should not exceed **25-30 Newton**.
- Doormats should be flush with the floor finish and firmly fixed to not cause a tripping hazard.

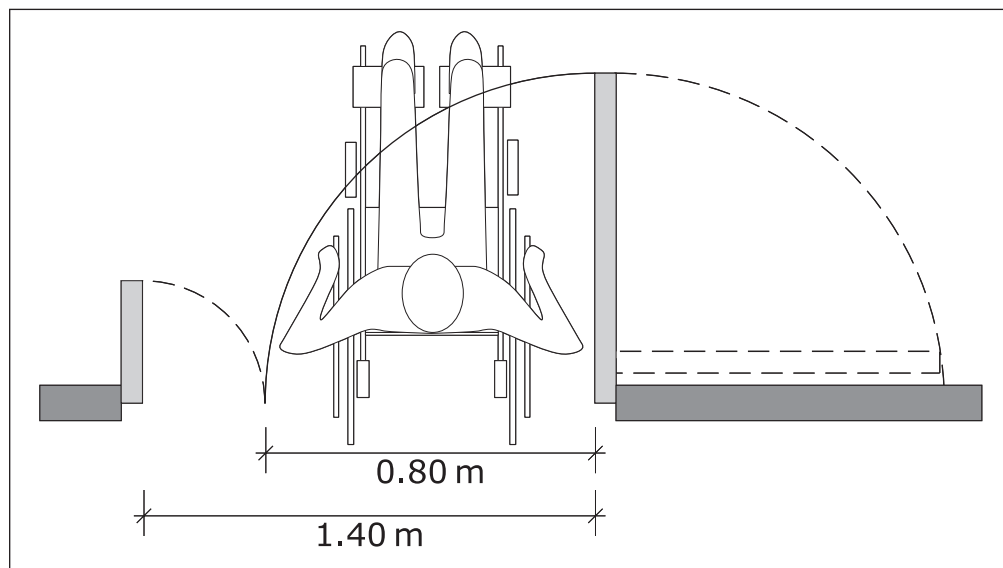

Fig.24: Design of double-leaf doors

➤ Automatic doors

Generally, automatic doors are the best solution for persons with disabilities.

- Automatic doors can be of the sliding or swinging type, but sliding doors should be preferred.
- Automatic doors should have an adequate opening interval to allow people with mobility problems easy access.
- Automatic doors can be activated by
 - contrasting push buttons, which should be located at a comfortable height between 0.90 m and 1.20 m,
 - activating mats which also serve as a location cue,
 - remote control,
 - card-insert switches, which should be located at least 2.50 m ahead of the opening door.
- Sensors or light barriers should be installed to avoid accidents.
- Automatic doors should be indicated as such.

Note:

Revolving doors are not suitable for persons with disabilities!



➤ Thresholds

Thresholds greater than 6 mm can create a trip hazard and thresholds greater than 10 mm are likely to impede access for wheelchair users.

- All thresholds should be removed, if possible.
- If thresholds cannot be avoided and do not exceed 10 mm, they should be rounded.

5.2. Entrance Areas and Lobbies

Purpose

To provide entrance areas, lobbies and associated features which are accessible to everyone.

Design principles

In general, entrance areas and lobbies should be well and glare free illuminated (see section 3.2.) with a clear and consistent signage system to facilitate easy orientation.

➤ Reception desks

- Reception desks should be located in clear view of the entrance doors, well signed and easy to identify using high contrast colour schemes.
- To facilitate orientation, it is useful to create a path leading to the reception desk using contrasting floor colours or finishes (e.g. from carpet to vinyl) ensuring flush floor finishes.
- The installation of a hearing enhancement system might be considered, if feasible.
- To ensure full accessibility of the reception desk for wheelchair users, a section should be at least 0.75 m from floor finish but no higher than 0.90 m (lower edge being at a minimum height of 0.70 m).
- Unobstructed knee space should be provided at least 0.60 m deep underneath (Figure 25).
- The utilisation space of 1.50 m x 1.50 m needed by wheelchair users should be considered in the design.
- All available information should be made accessible and provided in alternative formats to blind people and people with low vision or hearing impairments.

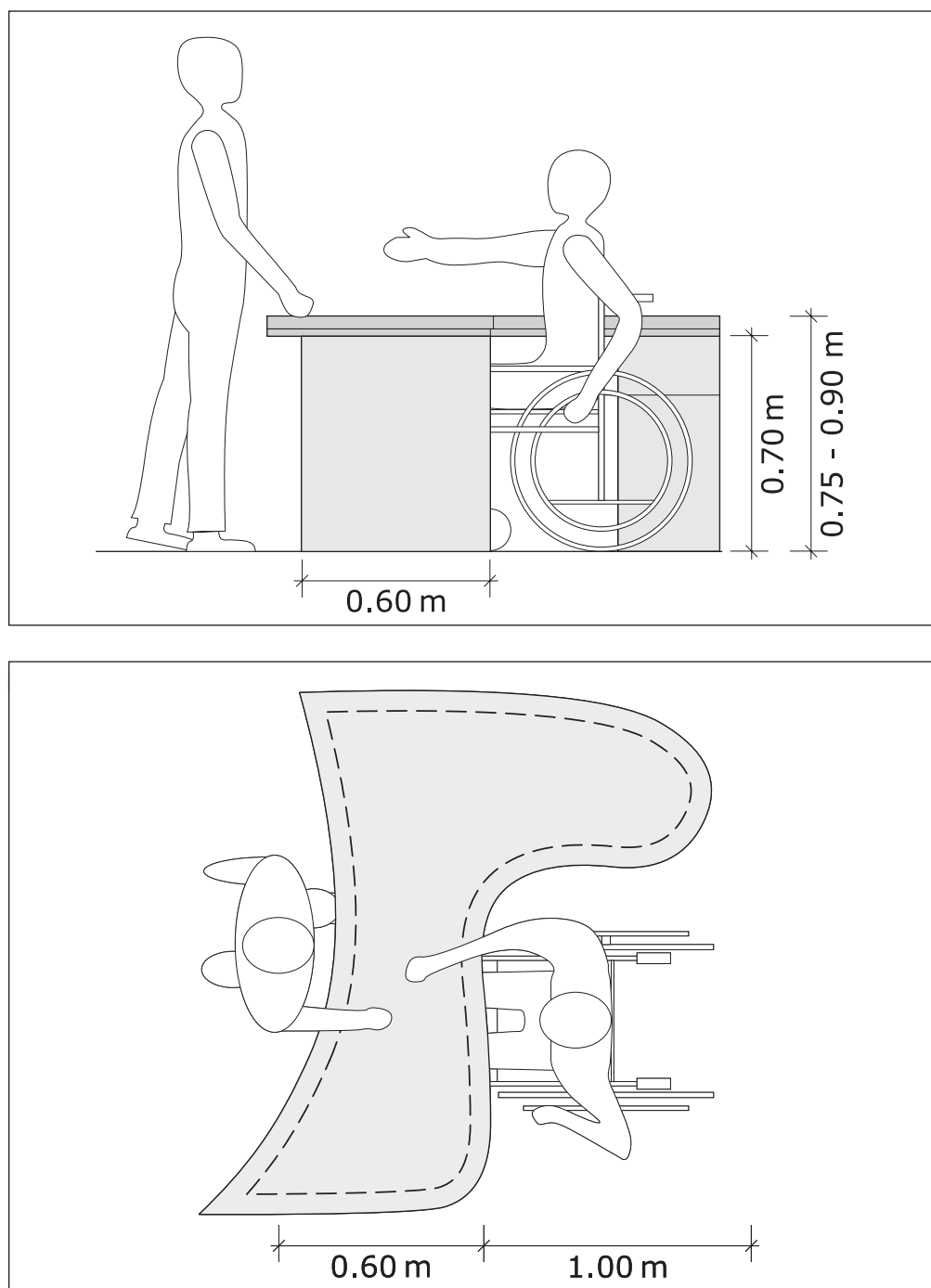

Fig.25: Design of an accessible section of a reception desk.

- Waiting areas
- If possible, waiting areas should be equipped with visual and acoustic calling systems.
- Public telephone booths



At public telephone booths, one telephone should be accessible to wheelchair users and have the following features (Figure 26):

- The "5" should have a raised pip to allow for easy use by blind people.
- The coin slot should be mounted at a height between 0.90 m and 1.20 m.
- A minimum area of 1.20 m x 0.85 m should be provided in front of the telephone counter to allow both parallel and frontal approach.
- The telephone cord should be at least 0.75 m long.
- Accessible telephones should be identifiable as such by appropriate signage (see Appendix 8.1).
- A folding seat should be provided at accessible telephone booths for people with mobility problems.

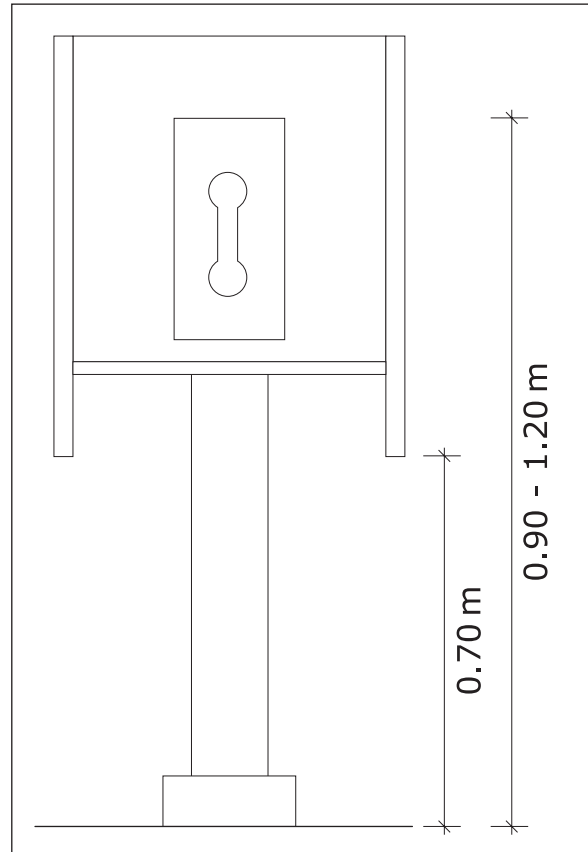

Fig.26: Public Phone wall installed

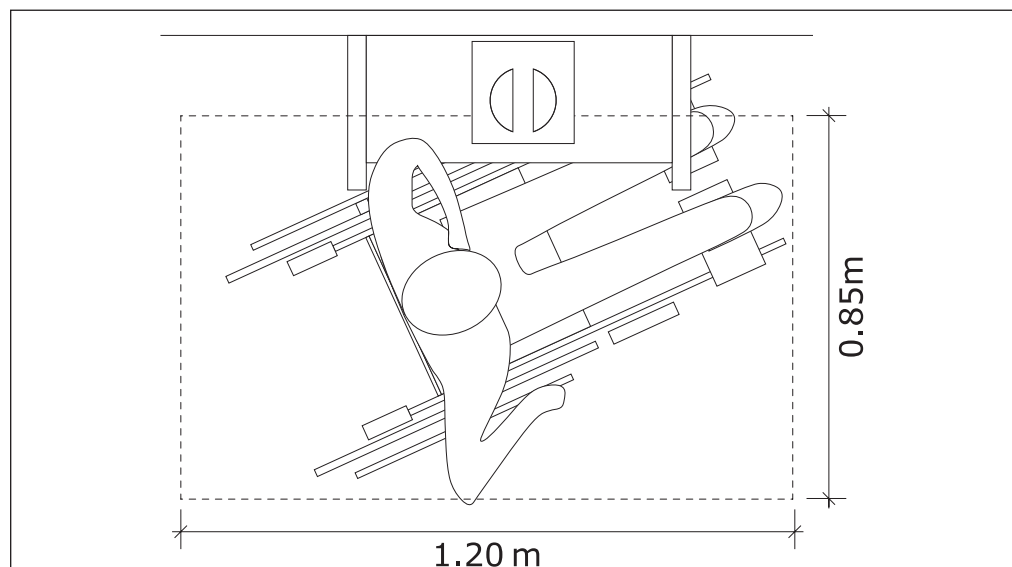

Fig.26 a: Parallel approach

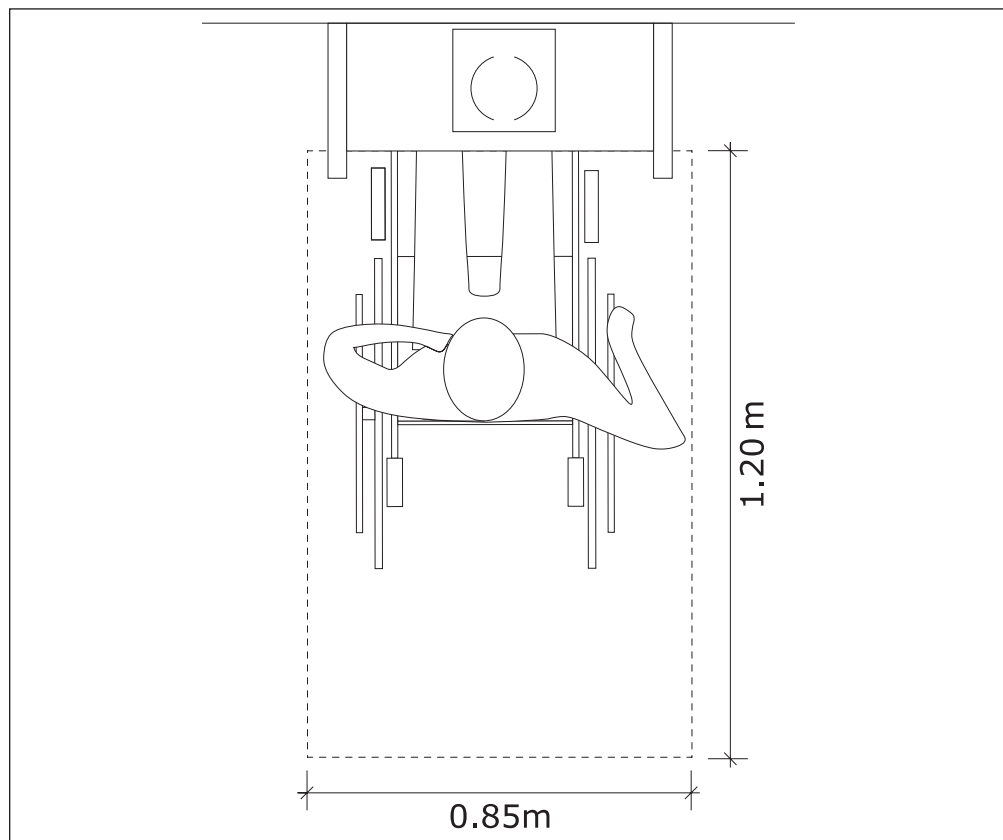

Fig.26 b: Frontal approach

Fig.26 a-b: Installation and design of accessible telephones

Preferably, one telephone should be accessible to people with hearing impairments:

- They should be provided with hearing aid devices and amplifiers.
- The location of telecommunication devices should be indicated with appropriate signage (see Appendix 8.1.).
- **Water Fountains**
 - Preferably, drinking fountains should have two spouts, one accessible to wheelchair users at a height of 0.80 m to 0.85 m and one at approximately 0.95 m to 1 m.
 - If all drinking fountains are installed at the same height, they should be located at 0.90 m.
- **Mailboxes**
 - Mailbox slots should be located at a convenient height between 0.90 m and 1.20 m.
- **Furniture/ Resting areas**



Generally, seating accommodations should be provided outside the main circulation path to allow for the free passage of all building users.

- Furnishings should contrast with the floor and the surrounding walls.
- Low (below knee-height) items such as coffee tables should not be used in public buildings.
- The height of tables should be between 0.75 m and 0.90 m with a minimum depth of 0.60 m under the table to suit wheelchair users.
- Public seats should be approximately 0.45 m above floor finish and have backrests.
- A selection of chairs with and without armrests should be available.
- In case of seating arrangements that are fixed to the ground, designated spaces for wheelchair users (1.50 m x 1.50 m each) have to be integrated.

5.3. Corridors

Purpose

To provide easily accessible corridors, which facilitate use and orientation for **all** users.

Design principles

Generally, corridors should be **as short as possible** to avoid orientation difficulties and if necessary, changes of direction should be at 90 degrees. In all cases, corridors should be left **unobstructed**.

Note:

Curved corridors or oblique angles should be avoided!

- Width of corridors
 - The unobstructed width of a public corridor should be minimum 1.50 m, preferably 1.80 m to allow easy passage of two wheelchair users or 180 turns for one wheelchair user (Figure 27).
 - In areas with low traffic or restricted space, corridors may have a width of less than 1.50 m, but at least 0.90 m to allow manoeuvrability for wheelchair users in 90 turns.
 - The width of a corridor must allow wheelchair users to manoeuvre through all doors located along the corridor (Figure 27).
 - **Obstacles** such as drinking fountains or resting facilities must be located outside the main circulation path, in cul-de-sacs or alcoves (Figure 27).

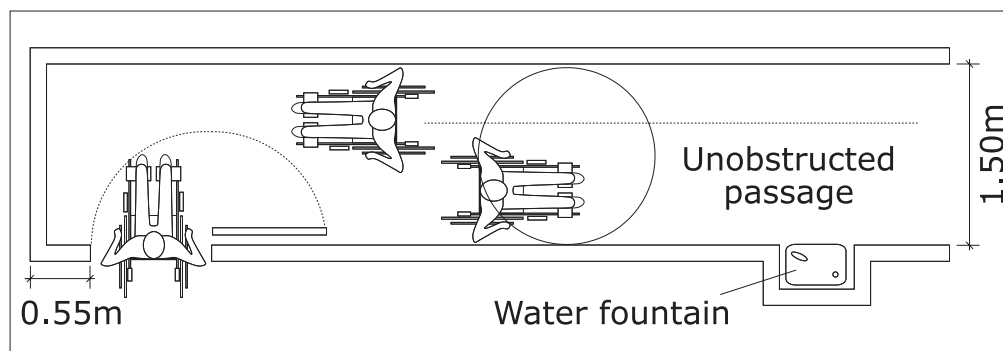

Fig.27: Corridor dimensions

- Height
- Clearances of at least 2.10 m should be provided to prevent people with visual impairments from hitting overhanging signs.
- Resting facilities in corridors

The maximum distances that people with mobility problems can walk without rest depends on various factors such as the walking surface and the slope. However, research in the UK has shown that only 20% of people with mobility problems using mobility aids such as walking sticks could manage to walk a distance of 180 m without rest (Leake et al. 1991). Furthermore, it has to be considered that standing for more than 10 minutes is difficult for many people with mobility problems. Hence, seating has to be provided wherever people may have to wait and along main circulation paths:

- Seating should be provided at regular intervals.
- Benches should allow a minimum of 1.20 m adjoining space for wheelchair users.
- Surface/ flooring of corridors
- The floor should be slip-resistant, easy to maintain and clean.
- If carpet is used, it should be firmly fixed to avoid slipping.
- Any changes in the surface level of more than 13 mm should be ramped (see also Section 5.1.).

5.4. Handrails and railings

Purpose

To provide suitable railing wherever needed, particularly for people with mobility problems.



Design Principles

Handrails should always be provided around all hazardous areas, stairs, ramps, accessible roofs, galleries, balconies and platforms.

- Form and design of handrails (Figure 28)
 - Handrails should be tubular or oval in section; sharp edges should be avoided.
 - Handrails should have a diameter of 40 mm to 50 mm.
 - Handrails should be formed from materials that provide good and easy grip such as timber, nylon or powder coating.
 - Handrails should be supported on brackets, which do not obstruct continuous hand contact.
 - Particularly in public buildings, handrails should contrast in colour and tone with the surrounding surfaces to alert people with sight problems.

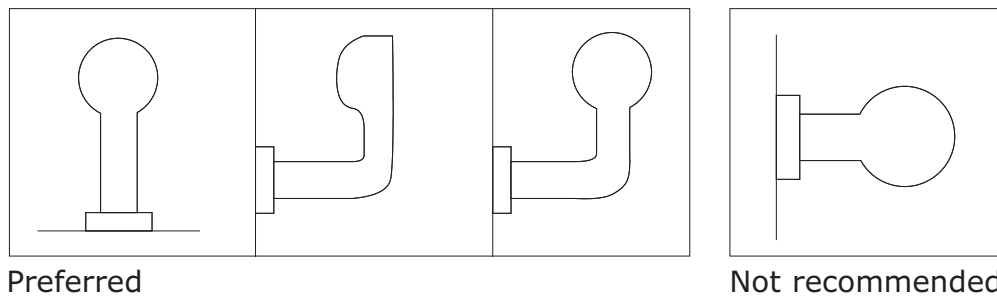
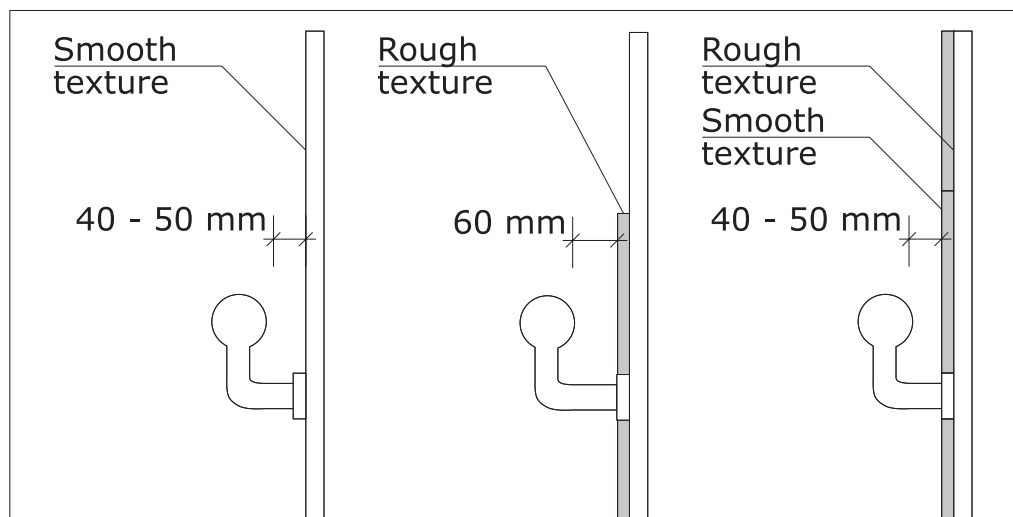
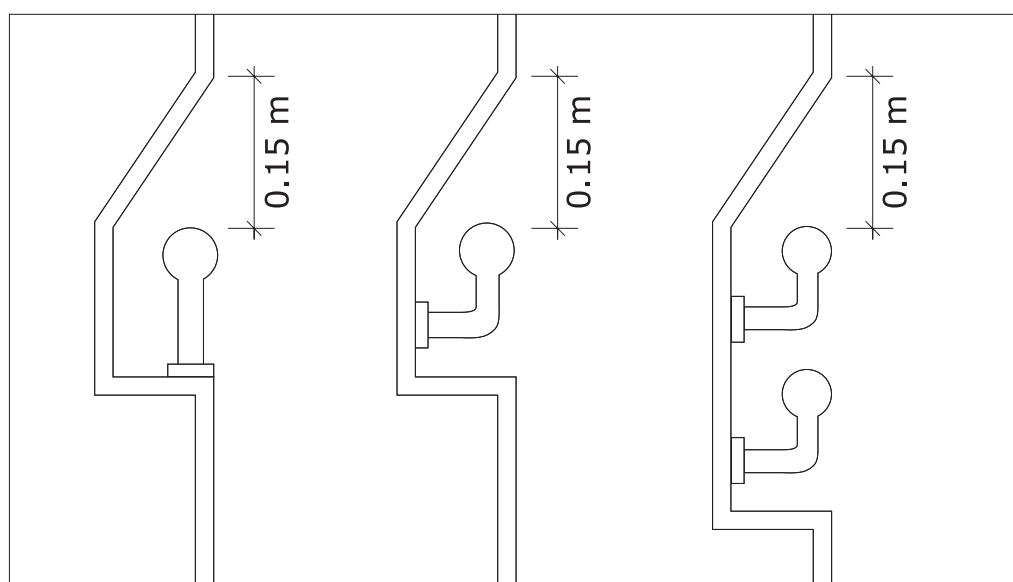

Fig.28: Recommended and inadequate forms of handrails

- Wall-mounted handrails
 - The space between handrail and wall should be between 40 mm and 50 mm for smooth walls and 60 mm for rough textured walls (Figure 29 a).
 - In case of handrails fully recessed into the walls, a space of minimum 0.15 m between the top of the rail and the top of the recess should be ensured (Figure 29 b).

**Fig.29 a****Fig.29 b****Fig. 29 a-b:** Installation of wall-mounted handrails

- Installation of handrails and railings
- Handrails should be mounted at a height between 0.80 m and 1 m.
- Handrails for stairs and ramps
- Continuous handrails should be provided on both sides of stairs and ramps (except for doorways) and around landings.



- Handrails must extend horizontally 0.30 m minimum beyond the top and bottom of stairs and ramps either returning to the wall or with a positive end that does not obstruct the pathway (Figure 30).
- For stairs or ramps wider than 3 m, an intermediate handrail could be provided.
- For the benefit of children and wheelchair users (for ramp), an additional handrail can be included at a height between 0.70 m and 0.75 m.
- To guide sightless people using a long cane on ramps, an extra rail should be mounted at a height between 0.10 m and 0.15 m (Figure 30).

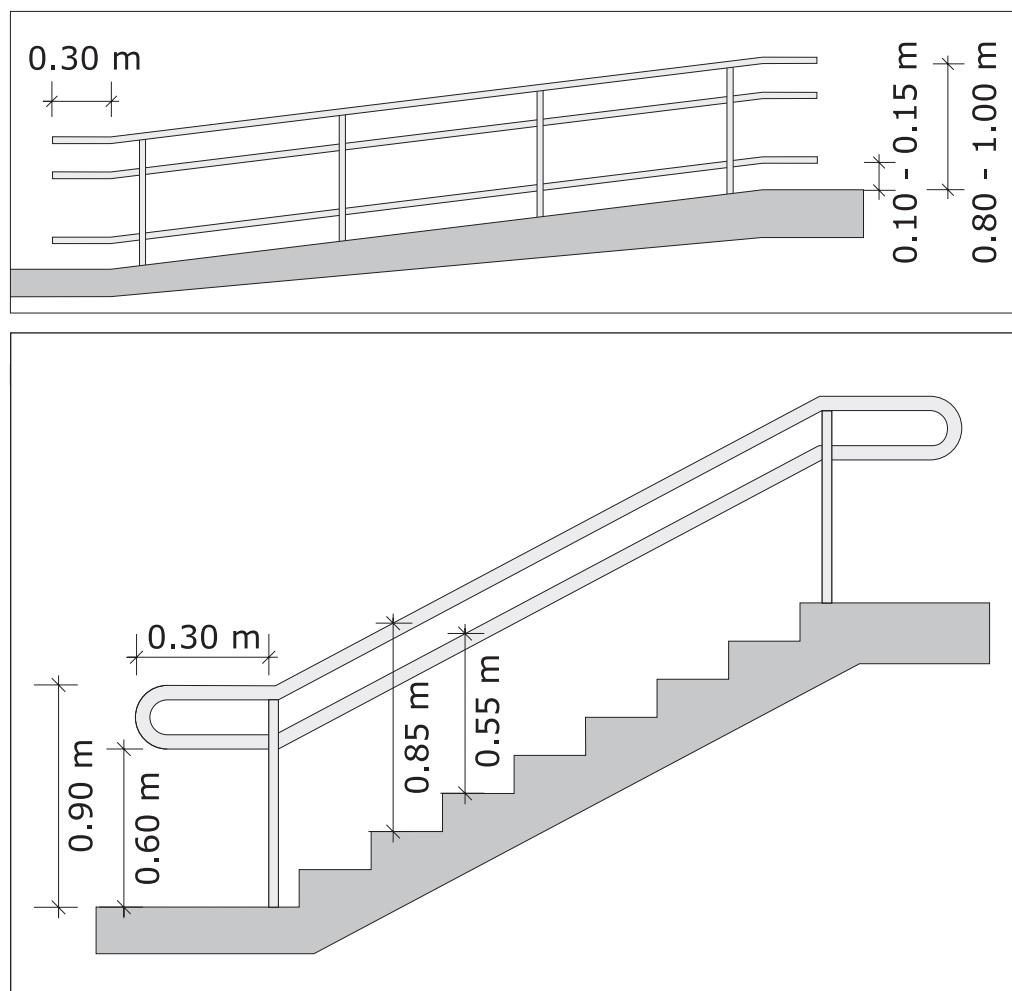

Fig. 30: Handrails for stairs

- Tactile marking on handrails
- Handrails in public buildings should be used to convey important information to blind people (see also section 6.).



5.5. Restrooms / Toilets

Purpose

To provide wheelchair accessible toilets and bathrooms with adequate space, fixtures and fittings at a convenient height for people with mobility problems.

Design Principles

Accessible toilets should be available on every floor open to the public. If this is not feasible, each public building should be provided with at least one accessible toilet.

Accessible toilets marked as '**unisex**' are preferred to separate male and female ones as they can also be used by people who are accompanied by an assistant of the opposite sex.

Crucial for the design of an accessible toilet is the provision of **sufficient space** for wheelchair users or people using other equipment, the instalment of **easy-to-use amenities** at a convenient height and the provision of **adequate handrails and grab bars** to assist people moving from a wheelchair or people with reduced strength.

Note:

In public buildings ideally the toilet should be placed near to the meeting rooms, and certainly on the same floor as the principal meeting rooms.

- Toilet dimensions
 - Generally, turning circles of 1.50 m allowing full-turn manoeuvring of a wheelchair are recommended.
 - Generally, there are four different approaches for wheelchair users to the toilet seat:
 - The diagonal approach
 - The perpendicular approach
 - The frontal approach
 - The parallel approach



To ensure the easy transfer from a wheelchair to the toilet seat, WC dimensions should allow for a **parallel approach** of the wheelchair user to the toilet seat, which proved to be the easiest (Figure 31).

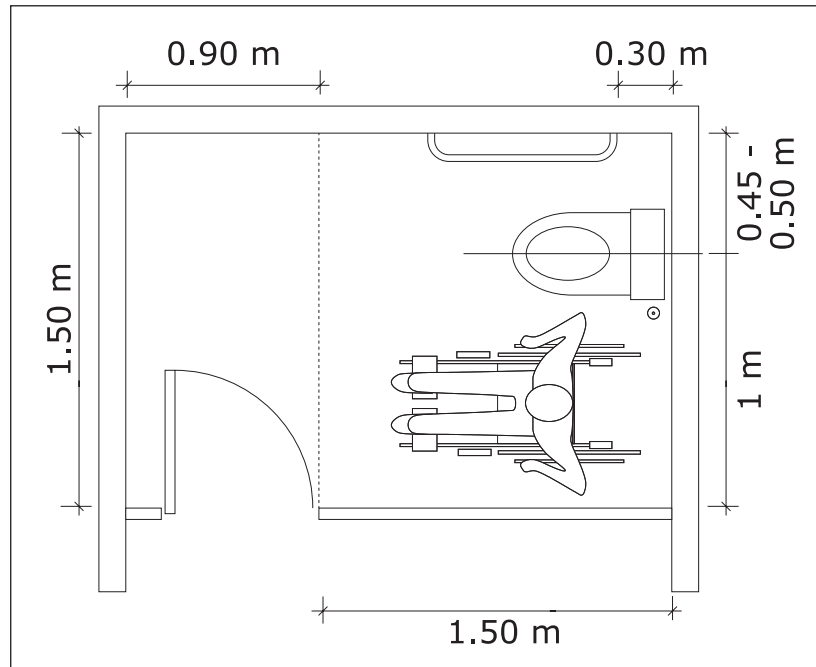

Fig.31: Examples of toilet designs allowing parallel approach

➤ The water closet

- Generally, wall-mounted water closets are recommended.
- The convenient height of a toilet seat for wheelchair users is at 0.45 m to 0.50 m, which is equal to the height of the wheelchair seat (Figure 32).
- If the adjacent wall is provided with a grip bar, the distance between the centre line of the toilet seat and the wall should be between 0.45 m and 0.50 m to allow for easy reach of the bar (Figure 31).
- The flushing arrangements should be located accessible on the open side of the water closet at a height between 0.50 m and 1.20 m from the floor.

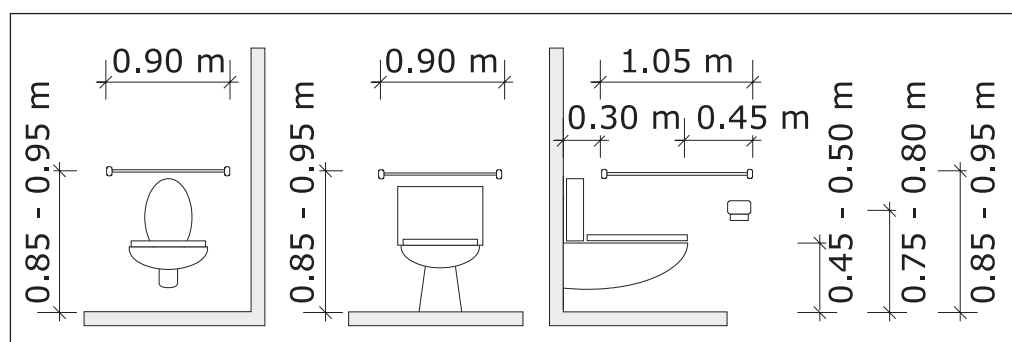

Fig.32: Accessible water closet

**Note:**

An example for adaptable seating devices for Asian squatting pans are locally produced transportable folding seats for wheelchair users!

Figure 33 shows the application of transportable folding seats for wheelchair users in Sri Lanka. The folding seat is produced by a local producer for assistive devices, which provides training and employment workshops for persons with disabilities.



Fig.33: Transportable folding seats adjusted to a toilet seat and a squatting pan.

➤ Grab bars

Generally, grab bars should be installed next to water closets, in showers and bath tubs to allow for the safe and easy use of the facilities.

- Grab bars should have a diameter of 30 mm to 40 mm.
- Particularly in public buildings, the colour of grab bars should contrast with the wall finish.
- Grab bars should be firmly fixed since considerable pressure will be placed on the rail.
- Grab bars should be mounted at a height between 0.85 m and 0.95 m from the floor (Figure 32).
- In case of wall mounted grab bars, the distance between the rail and the wall should be 35 mm to 45 mm.
- In case of water closets with no adjacent wall beside, a grab bar at each side should be installed.
- Next to toilet seats, grab bars should extend horizontally ca. 0.15 m.
- Particularly for public buildings, drop-down hinged rails, which can be stored in the vertical position and may also incorporate a tissue holder, should be considered.

Note:

If grab bars have not been provided in the initial construction, walls might need to be reinforced to withstand the loads!

➤ Accessories

- Accessories such as soap dispensers, towel-rails and tissue holder should be placed at a convenient height between 0.50 m and 1.20 m from the floor in accessible toilets.

➤ Mirrors

- The bottom edge of the mirror should be at a maximum height of 1 m from the floor finish (Figure 34).
- To allow for use both in standing and seated position, downward tilted mirrors can be used.

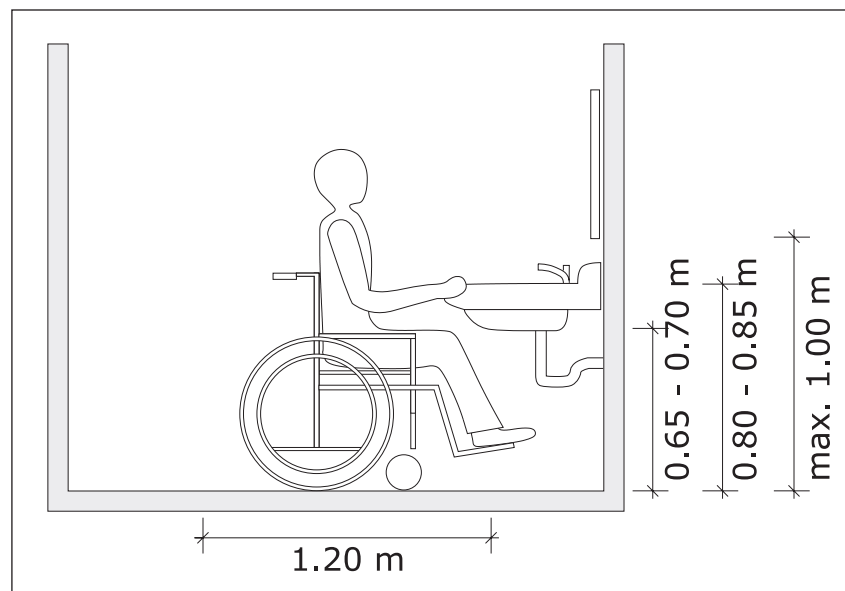

Fig. 34: Installation of washbasin and mirror

➤ Washbasins

- The height of washbasins should be between 0.80 m and 0.85 m above floor finish (Figure 34).
- The distance between the centre line of the washbasin and the adjacent wall should be at least 0.45 m.
- Above all, washbasins should be installed firmly as considerable pressure might be placed on them.
- If feasible, the fitting on cantilevered brackets should be preferred.
- Single lever mixer taps that are fitted on the side of the basin closest to the WC are useful as they allow hot and cold water to be used from a seated position on the WC.



➤ Alarm system / Emergency situation

All toilet facilities / bathrooms in public buildings should be equipped with an alarm system, which is easy to identify as such.

- Alarms or pull cords should be located close to the toilet seat (Figure 35).
- The alarm system should provide some form of feedback (visual / auditory) to confirm that help is on its way.
- Doors should be releasable from the outside under emergency situations.
- The toilet should be equipped with the alarm cord reachable both from seated position and when lying on the floor.



Fig. 35: Emergency system for restrooms / toilets

Note:

It has to be ensured that each emergency call will actually be attended to!

5.6. Showers

Purpose

To provide easy to use shower facilities with sufficient space and conveniently located fixtures and fittings for people with mobility problems, particularly wheelchair users.

Generally, showers should be preferred to bath tubs particularly in residential housing, as latter are difficult to use by wheelchair users without assistance and special equipment such as a lift.

Design Principles

- Shower fittings
- Shower controls should have clearly visible signs, ideally with tactile raised symbols for on/off and hot/cold.



- A grab bar should be located at a height between 0.85 m and 0.95 m opposite the wall and around the back wall (Figure 36).
- The showerhead should be fixed to a flexible hose and slider fitting allowing adjustment in height between 1.20 m and 1.90 m.
- The controls should be placed minimum 0.30 m away from any sidewalls.

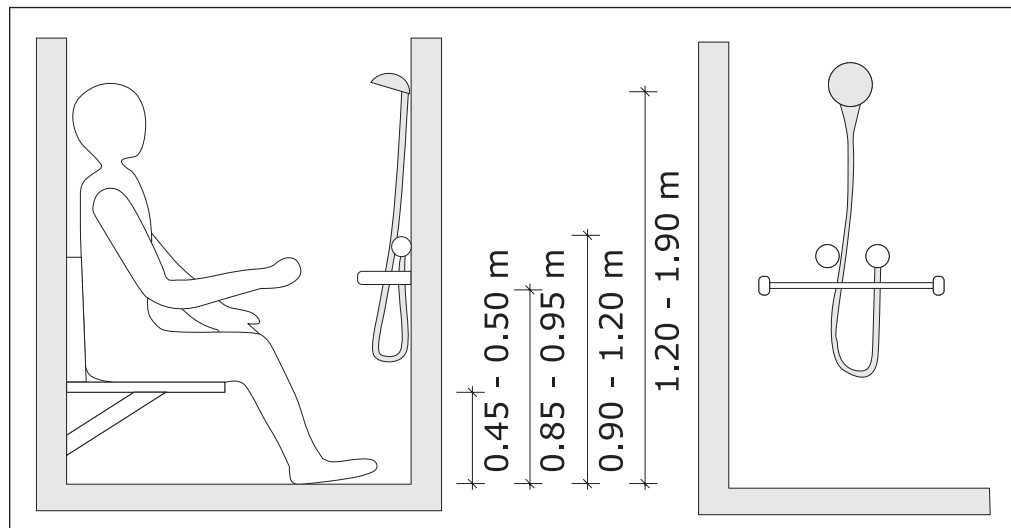

Fig. 36: Location of shower fittings

- Dimensions and equipment of shower compartments
 - Generally, the internal dimensions of a shower compartment depend on what other facilities are included (e.g. WC or wash basin). However, they should comply with minimum requirements (Figure 37).
 - All shower compartments should allow for unobstructed transfer from a wheelchair to a fold-down shower seat.
 - Showers should have a shower seat conveniently positioned at a height between 0.45 m and 0.50 m (Figure 36).
 - The shower seat should be removable or of pull down type, spring loaded seats are not recommended.

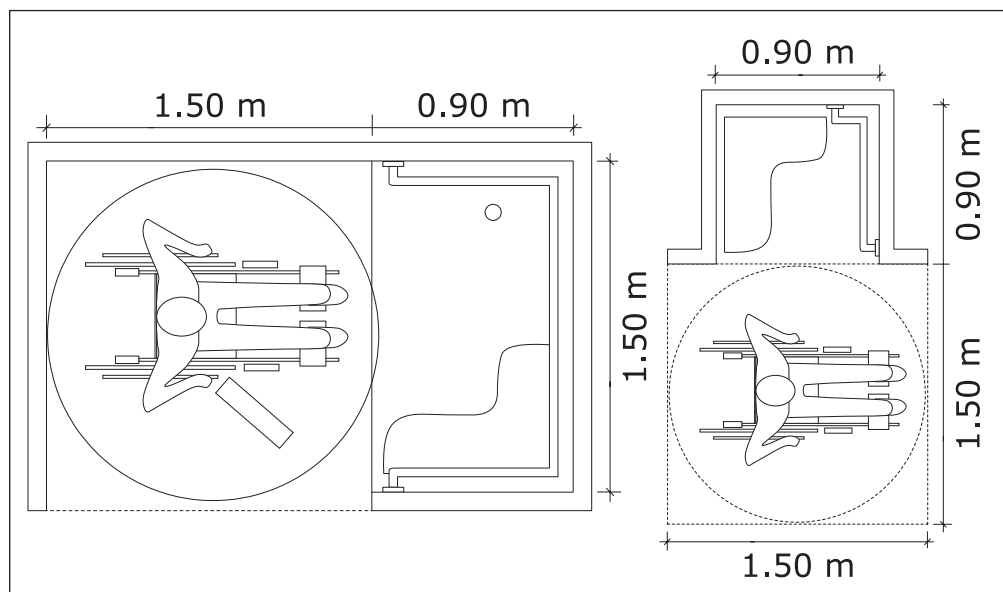

Fig. 37: Minimum dimensions for a shower compartment

➤ Flooring

- If possible, any thresholds should be avoided in the shower compartment.
- If thresholds cannot be avoided they should be bevelled and not exceed 10 mm above floor finish.
- However, recommended is a shower stall with a sloping floor (1:40 to 1:50) with trapped outlet and a non-slip waterproof finish.

Note:

The shower stall should be equipped with an alarm system with the alarm cord reachable both from seated position and when lying on the floor!

Notes: _____



Guiding System for Blind and Visually Impaired Persons



6. Guiding System for Blind and Visually Impaired Persons

Purpose

To support the inner orientation of blind persons with a continuous guiding system in a building.

Design Principles

A consistent and continuous guiding system has great impact on the personal mobility of blind persons when moving around. In the prior sections, some elements have already been included. This section summarises the different means of orientation that should be provided to facilitate the independent movement of blind and visually impaired persons.

➤ Tactile warnings

Where the path leads to a dangerous situation or change of level, tactile warning should be used: Within buildings, tactile warning markings should be located at

- Top and bottom of **stairs**
- Top and bottom of **ramps** and
- Around **obstructions**

➤ Tactile warning markings have a different texture to the surrounding floor finish and can be detected by people using a long or guide cane and also underfoot by people with low vision.

- At top and bottom of stairs and ramps, textural marking strips should be at least 0.60 m deep extending over the full width of the stairs or the ramp.
- Around obstructions, the warning markings should extend over a width of 0.60 m outside the hazardous area.

➤ Tactile guide way

- Tactile guide ways have a contrasting texture to the surrounding floor finishes (e.g. change from carpet to vinyl).
- A raised height of only 5 mm for tactile guide ways is already sufficient for almost all people with visual impairments to be detect-

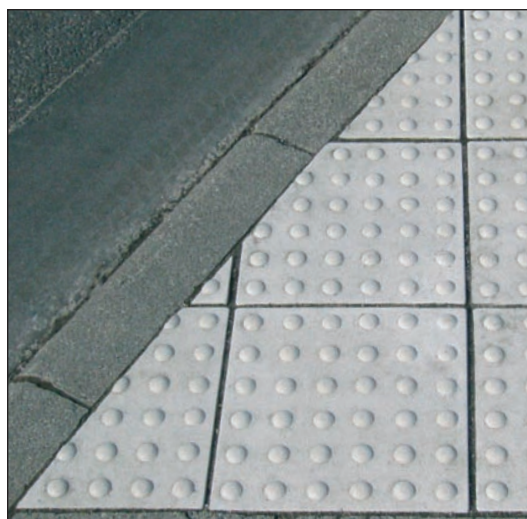

Fig. 38: Tactile system for orientation at street crossing



- ed without presenting a tripping hazard (Figure 39).
- The tactile guide ways should extend to all public floors.
 - Tactile guide ways should guide blind people and people with visual impairments from the main areas such as lobbies and entrance areas to the individual corridors and to tactile information panels.
 - The tactile guide way system should include all functional elements such as receptions or waiting areas.
 - Turnoffs and crossings may be indicated by a change of structure of the guide way (Figure 38).



Fig. 39: High contrasting, tactile and bevelled applications on pedestrian way

Note:

All emergency and evacuation routes should be provided with tactile guide ways!

- Provision of tactile information
 - To assist blind people or people with low vision, key information should be provided in tactile form (such as on control buttons, on signage next to lifts and at the top and bottom of stairs to indicate floor levels, on signage next to entrance doors etc.).
 - Particularly in public buildings, provision of a tactile building map in the entrance area should be considered.
 - This should be in the form of slightly embossed characters (1-2 mm) with a height of at least 15 mm and painted to contrast with the surface.
 - Particularly in low-income countries, usage of letters, numbers and symbols or pictograms may be more user friendly as fewer people use Braille.
 - If handrails are provided along corridors, they should convey tactile information (as well as maintain a line of travel).
 - Different materials, texture changes or raised symbols (see above) could indicate floor levels, room numbers or key information such as "stairs are being approached".

Note:

All emergency call buttons throughout a building should be provided with tactile information!



Notes: _____





Accessibility for Deaf, Hard of Hearing and Deafblind Persons



7. Accessibility for Deaf, Hard of Hearing and Deafblind Persons

7.1. Colour and Contrast

- For better orientation.
- Avoid glare: use matt instead of glossy colours.
- Floors to have great contrast to walls.
- Borders to edgings between floors and walls clearly marked.
- Walls and ceiling in light colour but not white.
- Handles to be in clear contrast from background (e.g. at doors or walls).

7.2. Design and Tactile Information

- Inner and outer walls should have different tactile properties.
- Uniform design is important, otherwise there is too much information given.
- Use different shaped handles to give contrast and also to distinguish between different functions (e.g. main entrance, offices, bathrooms, etc.).
- Stairs and handrails to have tactile markers on the top/bottom stair/part, whose meaning has been defined conventionally, to mark which floor a person is now on.
- Textiles on walls can help orientation.

7.3. Material and Acoustics

Ensure appropriate acoustics in reception areas and conference rooms.

- Hard floors can create hard sounds.
- For conference rooms sound regulation via induction loops is ensured and clearly marked.
- Alternatives for acoustic information like signals at the elevator, loud-speaker announcements, etc. have to be provided.

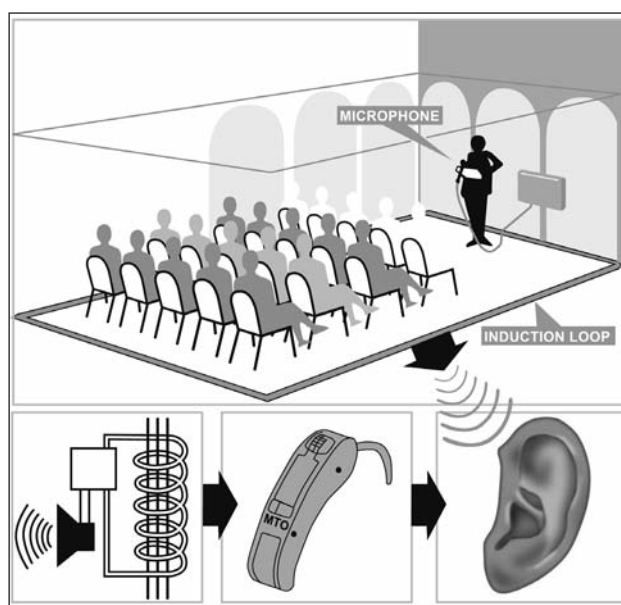

Fig. 40: Induction loop System and sign



7.4. Emergency Systems

- Emergency alarm systems to have audible and visible notification systems.
- Simple floor plans of the building indicating the location of and routes to usable circulation paths should be available in alternative formats such as single-line, high-contrast plans.
- The buildings to have two-way communication (to receive and transmit messages) devices installed in the elevators and areas of refuge/rescue assistance so that users can place a call for evacuation assistance.
- For emergency preparedness: deaf/deaf-blind persons to determine how to communicate with colleagues and emergency personnel if there is no interpreter or if hearing aid(s) are not working.

Notes: _____



Appendices



8. Appendices

8.1. Universal Accessibility Logos

Below you will find a selection of universal symbols that are used to indicate and publicise accessible places, features and services for persons with various disabilities. To facilitate orientation, directional signs should be added at main entrances and doors and in places where changes of direction occur.

Any comments accompanying the symbols should focus on the provided service and not on the potential user: For example, "Ramped Entrance" may be combined with the wheelchair symbol as not only wheelchair users use ramps but so do people with baby carriages, luggage or everyone else.



The wheelchair symbol identifies accessible facilities for persons with limited mobility including wheelchair users. In case of completely accessible buildings, only one explanatory sign at the principal entrance is needed.



This symbol indicates accessible services and facilities for persons who are blind or have low vision. This may include for instance a guided or tactile tour.

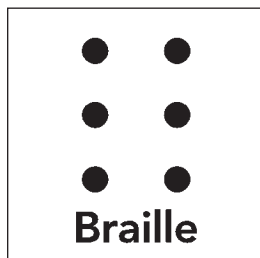

The Braille symbol indicates the use of Braille and the availability of printed information in Braille, including publications, labelling or signage.

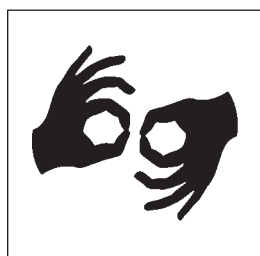

This symbol indicates that Sign Language Interpretation is provided for persons who are deaf or hard of hearing.



This symbol indicates the location of telephones that have handsets with amplified sound and/or adjustable volume controls.

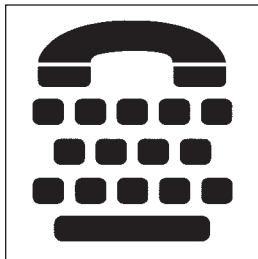

This symbol indicates the location of a Telephone Typewriter (TTY), also known as Text Telephone (TT) or Telecommunication devices for the deaf (TDD). TTY allows communication with and between deaf, hard of hearing, speech impaired and/or hearing persons through the use of a keyboard for input and a digital screen or a roll of paper to view the message.



This symbol indicates on signage or on floor plans the location of an information desk where more detailed information on accessible services and features is available.



This symbol indicates systems that transmit amplified sound via hearing aids, headsets or other devices. They include infrared, loop and Frequency Modulation (FM) systems.



This symbol indicates that captions, which translates dialogue and other sounds in print, are always displayed on the videotape, movie or television program. Open Captioning is preferred by many including deaf and hard-of-hearing individuals, and people whose second language is the language displayed (e.g. English).

The image shows the CC symbol, which consists of two bold, black, sans-serif capital letters 'C' and 'C' positioned side-by-side. The symbol is centered within a white square box with a thin black border.

This symbol indicates a choice for whether or not to display captions for a television program or videotape. TV sets that have a built-in or a separate decoder are equipped to display dialogue for programs that are captioned when selected by the viewer.

The image shows the AD symbol, which consists of the letters 'A' and 'D' in a bold, black, sans-serif font, followed by three curved lines that resemble sound waves. The symbol is centered within a white square box with a thin black border.

A service for persons who are blind or have low vision that makes the performing arts, visual arts, television, video, and film more accessible. Description of visual elements is provided by a trained Audio Descriptor through the Secondary Audio Program (SAP) of televisions and monitors equipped with stereo sound.

The image shows the Large Print symbol, which consists of the words 'Large' and 'Print' stacked vertically in a bold, black, sans-serif font. The symbol is centered within a white square box with a thin black border.

The symbol for large print is "Large Print" printed in 18 pt. or larger text. In addition to indicating that large print versions of books, pamphlets, museum guides and theater programs are available, you may use the symbol on conference or membership forms to indicate that print materials may be provided in large print. Sans serif or modified serif print with good contrast is important, and special attention should be paid to letter and word spacing.





8.2. The EIDD Stockholm Declaration[©]

"Good design enables, bad design disables"

Introduction

Soon after its establishment in 1993, the European Institute for Design and Disability (EIDD) developed the mission statement: "Enhancing the quality of life through Design for All".

After ten years as the European platform on Design for All, involving the development of external relations and an internal structure – national member organisations, corporate members and individual members now in sixteen European countries – EIDD believes that the time has come to issue a Design for All Declaration.

Design for All has roots both in Scandinavian functionalism in the 1950s and in ergonomic design from the 1960s. There is also a socio-political background in Scandinavian welfare policies, which in Sweden in the late 1960s gave birth to the concept of "A society for all" referring primarily to accessibility. This ideological thinking was streamlined into the United Nations Standard Rules on the Equalisation of Opportunities for Persons with Disabilities, adopted by the UN General Assembly in December 1993. The focus of the UN Standard Rules on accessibility in a clear equality context has inspired the development of the Design for All philosophy, which became a generally accepted concept in EIDD at its Annual General Meeting in Barcelona in 1995.

Comparable concepts have developed in parallel in other parts of the world. The Americans with Disabilities Act contributed to the evolution of Universal Design, while Inclusive Design has gained ground in the UK.

Today, Planning and Design for All are being recognised increasingly as necessary elements in pro-active strategies for sustainable development.

The European Institute for Design and Disability, on the occasion of its Annual General Meeting in Stockholm on 9 May 2004, therefore adopts the following Declaration:

Across Europe, human diversity in age, culture and ability is greater than ever. We now survive illness and injury and live with disability as never before. Although today's world is a complex place, it is one of our own making, one in which we therefore have the possibility – and the responsibility – to base our designs on the principle of inclusion.

Design for All is design for human diversity, social inclusion and equality. This holistic and innovative approach constitutes a creative and ethical challenge for all planners, designers, entrepreneurs, administrators and political leaders.



Design for All aims to enable all people to have equal opportunities to participate in every aspect of society. To achieve this, the built environment, everyday objects, services, culture and information – in short, everything that is designed and made by people to be used by people – must be accessible, convenient for everyone in society to use and responsive to evolving human diversity.

The practice of Design for All makes conscious use of the analysis of human needs and aspirations and requires the involvement of end users at every stage in the design process.

The European Institute for Design and Disability therefore calls on the European institutions, national, regional and local governments and professionals, businesses and social actors to take all appropriate measures to implement Design for All in their policies and actions.

Source:

www.designforalleurope.org/Design-for-All/EIDD-Documents/Stockholm-Declaration



8.3. Accessibility Audit

The purpose of an access audit is to assess how a particular building or environment performs in terms of access and ease of use by a wide range of actual and potential users, including persons with disabilities, and to recommend access improvements.

It is advised to conduct an access audit at various stages of the planning and design processes (access appraisal) as well as during ongoing construction or refurbishment work. The process of an access audit comprises a **site inspection**, an **assessment of the management** and **use of a building or environment** and results in a **report** that identifies the accessible features as well as access problems.

Why?

An access audit gives a picture of the level of accessibility in a building or of an environment, detects points of good and poor access and identifies areas of need that are not catered for. If followed up and put into practice improved accessibility is of **benefit for everyone**.

Access improvements can often be made by no or little cost by increasing awareness and altering policies and procedures.

What to audit?

The audit should cover both **physical features** and issues of **management and use**. The here given list is not exhaustive but entails basic areas to look into.



Physical features:

- **External environment**
incl. transport links approach, parking, external ramps and steps
- **Entrance**
incl. visibility, entry controls, doors, thresholds
- **Reception area**
incl. layout, reception desk, waiting area, signs, visual and acoustic factors
- **Horizontal accessibility**
incl. ease of navigation, corridors, doors, directional information, internal surfaces
- **Vertical accessibility**
incl. internal steps and stairs, ramps, escalators, lifts
- **Bathrooms**
incl. general provision, accessible WCs, accessible shower facilities
- **Specific facilities**
incl. waiting areas, assembly areas, refreshment areas, etc.
- **Communication systems**
incl. telephones/text phones, audiovisual displays
- **Emergency egress**
incl. escape routes, refuges, alarms, emergency lighting
- **Signs and way finding**
incl. overall layout of a building, sign type and location, use of landmark features, maps and guides, colour and contrast, audible features
- **Lighting**
incl. overall in the building, outside and at the workplaces
- **Acoustic environment**
incl. background noise, hearing enhancement systems, acoustic conditions suitable for intended use

Management and use:

- **Access to information**
incl. publicity and information material, alternative formats, text phones, hearing enhancement
- **Attitude of staff and management**
incl. sensitisation and training in disability and accessibility issues
- **Management practices, policies and procedures**
incl. those relating to emergency egress
- **Maintenance issues**
in relation to achieving or maintaining accessibility
- **Use of the building**
the way in which the building or environment is used by the users (e.g. employees, visitors)



How to conduct an access audit?

The audit should always consider usability, how people move through the environment and how they use the facility safely and with greatest degree of independence.

Methodology

- Use checklists (see e.g. 8.5)
- Involve users, esp. persons with disabilities
- (Semi-)/structured interviews for assessing utilisation/maintenance
- Qualitative interviews to get more in-depth insight to individual behaviour and usage
- Participatory methods for assessment of inclusion (focus group discussions incl. mapping, diagramming etc. exercises)
- Picture/video documentation (for analysis and access report)

Equipment

At least:

- Tape measure
- Means of recording the information collected
- Camera and/or video camera

Where appropriate:

- A door weight measure
- A light meter
- A sound meter
- A gradient measure
- Means of testing an induction loop

The auditor or access consultant should judge what is reasonable as good practice standards, compared with the local/national legislative and social frameworks.

The audit report

The scope of the report and the standards against which access will be assessed should be confirmed prior to the audit.

Local Context:

CBM guidelines "Promoting Access to the Built Environment" provide general minimum standards which need to be aligned with the appropriate contextual standards and respective national regulations in each setting and country.



A standard audit report should always include:

- An introduction (describing the function of the building, how it is used, etc.)
- A detailed description of the existing access situation (positive and negative features; with dimensional information)
- Recommendations for improvement
- Priority ratings for the recommended improvements
- Cost information where required
- Summary (identifying the main points of the report)



8.4. Tips on Making the Workplace Accessible

The workplace can often be made accessible with minimum effort and expense. Everyday activities can sometimes be difficult for persons with disabilities. However, by making adjustments, we can create an accessible environment that will allow everyone to take advantage of facilities. Listed below are some of the areas for adjustments which can be made for easy access to, and within, the workplace:

- Outside / Entering the building
- Reception area
- Meeting others and taking breaks
- Changing levels / getting upstairs
- Toilets
- Work space
- Communications
- Meetings
- Performance

Outside/entering the building:

- Are disabled parking spaces available near the building entrance and are they clearly marked?
- Are the set down area and pedestrian routes clear of obstructions?
- Are there clear directional signs to the entrance of the building?
- Is there level or ramped access at the entrance to avoid steps?
- Are pathways and ramped access slip resistant?
- Are there visual or other indicators in place for individuals who are hearing impaired or deaf?
- Is the location of doorbell or intercom at an accessible height for a wheelchair user?
- Are there audio or warning sounds, which indicate opening or closing movement of doors, etc.?
- Is there a good level of lighting?
- Is the width of the doorway wide enough for a wheelchair user?

**The reception area:**

- Height of counters and desks may obstruct communication or cause difficulty for a wheelchair user, as would height level of public telephones, light switches, control buttons, coat rails, etc.
- May counters/reception partitioned with glass obstruct communication with a person with a hearing or speech impairment?
- Is the reception area roomy enough to allow wheelchair users get through other waiting visitors?
- Is there a good level of lighting?
- Have the receptionist and other staff members been trained to best facilitate persons with disabilities?

Meeting others and taking breaks:

- Is the width of the doorway wide enough for a wheelchair user?
- Are the corridors, canteen and all other areas generously sized and free from obstructions to allow everybody move around comfortably?
- Is there a good level of lighting (meeting rooms, corridors, etc.)?
- Are canteen facilities at a height to avoid accidents or spillage?
- Are provisions made for special dietary needs?
- Has the staff been trained to offer and give assistance, if needed and accepted?

Changing Levels:

- Is there a lift and is it sited in an area for easy access?
- Are there warnings at the top and bottom of stairs and other hazardous areas?
- Are the signposts legible and well lit?
- Are there any handrails along the stairs and the ramp?

Toilets:

- Are toilets accessible by lift or ramp if located on another level or floor?
- Is the width of the doorway wide enough for a wheelchair user?
- Is there sufficient room in toilets to allow a wheelchair user move around comfortably and free from obstruction?
- Are there any handrails near the toilet WC?
- Are hand dryers, switches, mirrors, etc. at an accessible height for all users?

Work space:

- Chairs should be at the proper height with back support and arm-rests
- The height of a desk or a table and free space under them should be considered for wheelchair users



- Roomy workspace, printing bay and storage rooms should be provided.
- Storage of files, stationary, etc. to be placed at an accessible low level, as with pigeon holes for post.
- On the telephone, e.g. volume control, manipulating buttons, using a microphone, etc. should be installed.
- Assistive Technology when using the computer, e.g. Screen Reader software, voice activation, headphones and/or speakers, screen magnification according to the needs of the employee is to be provided.

Communications:

- Blind means non-visual usage, with printed material causing difficulty. Therefore it is better in accessible electronic format.
- Deaf means sign language or paper-based communication. Audio is difficult, electronic is better.
- Learning difficulties means explaining the message. You may need to simplify or use plain language or visual graphics.

Meetings:

- Meeting rooms should be clearly signaled and identifiable.
- The width of the doorway should be wide enough for wheelchair users.
- Room for all attendants should be easy to move around without difficulty and with no obstructions.
- Documentation and reference materials should be also available in electronic or/and alternative formats.
- Background noise should be at a minimum. Preferably use a looped area.

Performance:

- Set a target or discuss the level of achievement to be expected.
- How will the performance be measured? Does a staff member with a disability have the same opportunities to train/retrain and develop their skills as other workers?

Source: www.workway.ie/the_workplace/making_the_workplace_accessible.418.417.html





8.5. Accessibility Check List

The following check list is a basic tool to assess architectural plans or existing buildings with regard to accessibility and gives hints on how to improve upon weaker areas.

However, ensuring accessibility is an ongoing process that involves the continuous identification of barriers and opportunities to increase access for persons with disabilities.

Questions	Possible measures
1. Entrance	
<ul style="list-style-type: none"> • Is the building entrance accessible to wheelchair users? 	<ul style="list-style-type: none"> ⇒ Provide a ramp, preferably at the main entrance.
Notes: _____ _____ _____	Notes: _____ _____ _____
2. Signage	
<ul style="list-style-type: none"> • Are accessible areas, features and facilities identified as such? 	<ul style="list-style-type: none"> ⇒ Mark accessible spaces, features and facilities with the respective international symbols.
<ul style="list-style-type: none"> • Is the location of accessible spaces, features and facilities indicated? 	<ul style="list-style-type: none"> ⇒ Provide directional signs to guide persons with disabilities or their assistants to the respective locations.
<ul style="list-style-type: none"> • Are all maps, information panels and wall-mounted signs placed at a convenient height between 0.90 m and 1.80 m? 	<ul style="list-style-type: none"> ⇒ Adjust the height of signage placed too high or too low.
<ul style="list-style-type: none"> • Is key information on signs supplemented with embossed letters or Braille? 	<ul style="list-style-type: none"> ⇒ Add tactile information.
<ul style="list-style-type: none"> • Are signs clear and easy to read? 	<ul style="list-style-type: none"> ⇒ Adjust letter size in proportion to the reading distance. ⇒ Use contrasting colours.



Notes: _____

Notes: _____

3. Corridors

- Are the corridors clear of obstructions?

 - ▣ Remove or relocate obstructions.
 - ▣ Provide obstructions or hazardous areas with tactile marking.

- Is the width for low traffic corridors at least 0.90 m and 1.50 m for public corridors?

 - ▣ Widen the corridors.
 - ▣ Remove obstructions and features that limit the width.
 - ▣ If widening of corridors is not feasible, passing areas should be located at regular intervals.

- Is the surface level, smooth and non-slip?

 - ▣ Repair holes and uneven areas.
 - ▣ Provide non-slip and even floor surfaces.
 - ▣ Ensure secure fastening of carpets.

- Is the path of travel easy to identify?

 - ▣ Provide visual and tactile guiding strips.
 - ▣ Provide visual and tactile marking to indicate the location of obstructions or changes of direction.

Notes: _____

Notes: _____



4. Doors

- Are the door openings at least 0.80 m wide?
 - Widen the doors accordingly.
 - Swing clear-hinged doors can be used to slightly enlarge the opening.
 - A door opening of 0.75 m can be sufficient if the access is straight and if the door stays open by itself.
- Do users have to pass over thresholds?
 - Remove thresholds higher than 6 mm.
 - If thresholds cannot be removed, they should be bevelled.
- Are the doors easy to open with one hand?
 - Heavy, hard to open swinging doors may be replaced by automatic doors.
 - Use lever-type door handles.
- Are the doors easy to identify?
 - Paint doors or door frames in a colour that contrasts with the adjoining walls and handles.

Notes: _____

Notes: _____

5. Differences in level

- In case of a multi stored building, is there a lift available to reach all public floors?
 - Provide a lift/ramp.
 - If fitting/re-fitting with a lift is not feasible or difficult, stairway lifts present an alternative.
- Does the lift cab have the minimum acceptable size?
 - Replace lift cabs smaller than 0.95 m x 1.25 m.
- Can the control buttons be reached when seated in a wheelchair?
 - Replace/lower control buttons mounted above 1.40 m, which is the maximum reach of a wheelchair user.
 - In case of two identical control panels, only one needs to be replaced.



- | | |
|--|---|
| <ul style="list-style-type: none"> • Within one floor, is the circulation route free of changes of level or steps and stairs? | <ul style="list-style-type: none"> ➤ Provide curb ramps/ramps. ➤ Provide an alternative accessible route. |
| <ul style="list-style-type: none"> • Is the maximum slope of planned/existing ramps or curb ramps 1:12? | <ul style="list-style-type: none"> ➤ Replace or redesign steep curb ramps and ramps. |
| <ul style="list-style-type: none"> • Are handrails provided to enhance safety when using ramps and stairs? | <ul style="list-style-type: none"> ➤ Place handrails next to stairs and ramps. |
| <ul style="list-style-type: none"> • Are stairs and ramps easy to identify? | <ul style="list-style-type: none"> ➤ Place slip-resistant colour strips to the nosing of stairs or paint the nosing (40 mm deep). ➤ Provide tactile marking strips at the top and bottom of stairs and ramps in a colour that contrasts with the surrounding floor. |

Notes: _____

Notes: _____

6. Waiting areas and associated facilities

- | | |
|---|---|
| <ul style="list-style-type: none"> • Are accessible facilities such as telephones identified as such? | <ul style="list-style-type: none"> ➤ Add adequate signage. |
| <ul style="list-style-type: none"> • Is there at least one telephone accessible to wheelchair users? | <ul style="list-style-type: none"> ➤ Adjust one telephone booth. |
| <ul style="list-style-type: none"> • Do the telephones have raised numerals to allow for tactile identification? | <ul style="list-style-type: none"> ➤ Install telephones with raised numerals. ➤ If not all numerals, at least the "5" should have a raised pip. |
| <ul style="list-style-type: none"> • Are resting facilities provided at a regular interval? | <ul style="list-style-type: none"> ➤ Provide seating facilities at least every 20 m. |



- Do resting facilities provide sufficient space for a wheelchair user? ➡ Rearrange the layout of seats to allow adjoining space of at least 1.20 m next to benches and seats.
- Are public seats between 0.45 m and 0.50 m high and the top of tables between 0.75 m and 0.90 m high with knee space at least 0.70 m high and 0.60 m deep? ➡ Replace or modify seats and tables that are too high or low.
- Are water fountains accessible to wheelchair users? ➡ Modify the height of drinking fountains.
➡ Install a double-tiered fountain.

Notes: _____

Notes: _____

7. Toilets/Restrooms

- Are there accessible toilets in a public building? ➡ Provide at least one accessible unisex toilet allowing turning circles of 1.50 m and including adequate grab bars.
- Is the accessible toilet marked as such? ➡ Indicate location of accessible toilet with the international symbol.

Notes: _____

Notes: _____



8. Emergency system

- Is the emergency route identifiable as such by people with visual impairments?
 - ▣ Provide tactile and visual guidance along emergency routes.
 - ▣ Provide audible alarm signals.
- Can an emergency situation be recognised as such by people with hearing impairments?
 - ▣ Provide flashing light signals.

Notes: _____

Notes: _____



8.6. References

- Barker, Peter (2003):
Buildings and Internal Environments, JMU Access Partnership
- Bundesministerium für Gesundheit (1996):
Verbesserung von visuellen Informationen im öffentlichen Raum.
Bad Homburg v.d.H., FMS Fach-Media-Service-Verlag
- Clarkson, J. and Keates, S. (2000):
A model for Inclusive Design.
Retrieved from
www.rehab-www.eng.cam.ac.uk/papers/lisk12/edc2000
- DFID Department for International Development (2000):
Disability, poverty and development.
London, DFID
- DFID Department for International Development (2004):
Enhancing the mobility of disabled people: Guidelines for practitioners.
TRL Limited, Berkshire, UK.
- Elwan, A. (1999):
Poverty and disability: A survey of the literature.
Social protection discussion paper series No. 9932. Social protection unit. Human development network. Washington DC, The World Bank
- ESCWA & SOLIDERE (2003-4):
Accessibility for the Disabled – A Design Manual for a Barrier Free Environment
(Retrieved 2005, from www.un.org/esa/socdev/enable/designm)
- Goldsmith, Selwyn (2000):
Universal Design.
Architectural Press, Oxford
- Leake, J.R. et al. (1991):
An ergonomic study of pedestrian zones for disabled people.
Crowthorne, TRL Limited
- Meriläinen, A. and Helaakoski, R. (2001):
Transport, Poverty and Disability in Developing Countries.
Technical note prepared for the Poverty Reduction Sourcebook.
Washington DC, The World Bank



- Stadt Münster (2005):
Bauen für Alle-Barrierefrei.
Koordinierungsstelle für Behindertenfragen
- United Nations (1993):
Standard Rules on the Equalization of Opportunities for Persons with Disabilities.
General Assembly Resolution 84/96 of December 20, 1993.
New York, United Nations

Useful Websites

Accessibility

- UN Enable: Accessibility for the Disabled. A Design Manual for a Barrier Free Environment:
www.un.org/esa/socdev/enable/designm
- European Concept for Accessibility:
www.eca.lu/
- Guideline on Accessibility in Urban Areas
DFID, Department for International Development (UK):
<http://www.globalride-sf.org/images/DFID.pdf>
- Inter-American Development Bank: Pathways to Accessibility: Disability and the Physical Environment:
<http://www.iadb.org/sds/doc/Rev2bEditedDisability-InfrastructureAlvarez.pdf>
- Community-Based Solutions:
<http://www.globalride-sf.org/images/DFID.pdf>
- Accessibility guidelines developed for Asia and the Pacific
ESCAP guidelines on non- handicapping environments:
<http://www.unescap.org/esid/psis/disability/decade/publications/z15009gl/z1500901.htm>

Colour Contrast

- Colour Contrast Check :
http://snook.ca/technical/colour_contrast/colour.html
- Effective Colour Contrast :
<http://www.lighthouse.org/accessibility/effective-color-contrast/>

Design for all

- European Institute for Design and Disability:
www.designforalleurope.org



- Stockholm Declaration:
www.designforalleurope.org/Design-for-All/EIDD-Documents/Stockholm-Declaration/

Disability Knowledge and Research

- <http://www.disabilitykar.net/>
- http://www.asksource.info/res_library/disability.htm

UN Convention on the Rights of Persons with Disabilities (UN CRPD)

- Convention Text:
<http://www.un.org/disabilities/documents/convention/convoptprot-e.pdf>
- Secretariat for the Convention on the Rights of Persons with Disabilities:
<http://www.un.org/disabilities/default.asp?id=17>
- Office of the United Nations High Commissioner for Human Rights: Status of the Convention on the Rights of Persons with Disabilities and its Optional Protocol:
<http://www2.ohchr.org/english/issues/disability/index.htm>

Assistive Devices

- Guidelines on the provision of Manual wheelchairs in less resourced setting. Published by: WHO, ISPO, USAID (2008)
www.who.int/disabilities/publications/technology/wheelchair-guidelines/en/index.html

Workplace Accessibility

www.workway.ie/the_workplace/making_the_workplace_accessible.418.417.html

Notes: _____





Experience Sharing and Good Practice
Examples on Accessibility



Additional Material



Additional Material



Please feel free to add your personal amendments

(national legislation, case studies, notes etc.).

