

**MANUAL**

**FOR THE**

**TRAINING OF COMMUNITY HEALTH  
EXTENSION WORKERS (CHEWS)**

**ON**

**LONG-ACTING REVERSIBLE  
CONTRACEPTIVE (LARC) METHODS  
(IUDs and Contraceptive Implants)**

- **Participants' Reference Book  
2015**

## FOREWORD

The unacceptably poor maternal and child health indices in Nigeria have been of much concern to various governments at all levels in the country. In efforts to address these unfavorable indices, Family Planning which is one of the pillars of safe motherhood is being vigorously implemented through series of interventions. Notable amongst these, is the introduction of Task Shifting policy for Community Health Extension Workers, CHEWS to provide Injectables with mentoring for ensuring wider coverage of FP services in the country. The success being achieved led stakeholders to seek for Federal Government's approval for the provision of Long Acting Reversible Contraceptive Methods (IUDs and contraceptive Implants) which was approved by the National Council on Health in 2014.

To this end the Federal Ministry of Health, Marie Stopes International Organisation Nigeria (MSION), Clinton Health Access Initiative (CHAI), United Nations Population Fund (UNFPA), and other partners met and developed a draft Training Manual, Participant Reference Book and Supervisory Checklist for impacting knowledge and skills on CHEWS to provide quality family planning services to clients who need IUDs and implant contraceptives. This intervention is expected to reduce the high unmet need for services and accelerate achievement of the target Family Planning Blueprint of 36 percent Contraceptive Prevalence Rate by the year 2018.

The Federal Ministry of Health recognizes and appreciates all the development partners, especially Marie Stopes Nigeria, for their efforts in making all these interventions realizable and assures partners of government supports for further efforts at improving the health and well-being of our women and children in the country.

May I say that it is one thing to develop valuable documents and it is another to make effective use of them. Therefore, it is my expectation that all stakeholders will make the best use of these manuals and checklist to improve skills of service providers for provision of quality family planning services in Nigeria.

I thank you all while strongly recommending the National Long Acting Reversible Contraceptive (LARC) Manuals and Supervisory Checklists for use to support provision of quality family planning services in the country.



**Professor Isaac Folorunso Adewole FAS, FSPSP, D.Sc (Hons)**  
**Honourable Minister of Health**

**November, 2015**

## ACKNOWLEDGEMENT

The 2015 Training Manual for Community Health Extension Workers (CHEWs) on Long – Acting Reversible Contraceptive (LARC) methods (IUDS & Implants) in Nigeria is the first of its kind developed in equipping Community Health Extension Workers (CHEWs) with required knowledge and skills for provision of Long Acting Reversible Contraceptive (LARC) methods in the country

A number of individuals and organizations had been involved in the rigorous process that culminated in the successful production of the Training Manual and they all deserve special commendation.

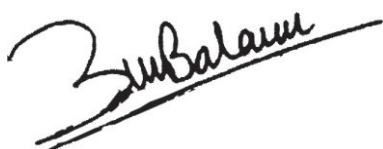
In this regards, I wish to express my appreciation to the staff of the Federal Ministry of Health who relentlessly put on efforts at developing the Training Manuals and Supervisory Checklists under the exemplary leadership of the Head Reproductive Health Division, Dr. Kayode Afolabi and the entire staff of the Reproductive Health Division of Family Health Department in the Federal Ministry of Health.

While conveying my sincere gratitude to Marie Stopes International Organisation Nigeria led by the Country Director Mr Effiom Effiom and the Chief of Party, Mr Onoriode Ezire, I appreciate the support of CHAI, SFH, USAID, JHPIEGO, USAID/DELIVER, NURHI, Pathfinder International, UNFPA and other partners not mentioned for their technical and financial supports. I also thank various State Ministries of Health and FCT as well as Regulatory Bodies particularly Community Health Practitioners' Registration Board and Nursing and Midwifery Council of Nigeria for their involvement in making the entire process a success.

There is also no gainsaying, the expertise knowledge and skills of the Consultants who developed the Manuals, Prof Adeyemi Adekunle and Dr. Kayode Osungbade have produced valuable documents for provision of quality family planning services on a wider coverage in the country, for which I am very grateful.

May I, in conclusion, emphasize that making effective use of this document by all concerned will be the only way of appreciating the efforts of stakeholders who produced these valuable Materials.

Thank you all.



Dr Wapada I. Balami mni  
Director, Family Health  
Federal Ministry of Health

## LIST OF CONTRIBUTORS

Dr Kayode Afolabi	Director/Head, Reproductive Health Division	FMOH
Mr Greg Izuwa	Deputy Director, Family Planning Logistics	FMOH
Mr Lawrence Anyanwu	Deputy Director, Family Planning Services	FMOH
Mrs Nneka Oteka	Asst. Director, Family Planning Services	FMOH
Mr Ralph Olayele	Asst. Director, Family Planning Logistics	FMOH
Mr Adeoye Adetunji	Asst. Director	NPHCDA
Mr Alex Ugochukwu	Chief Pharmacist	FMOH
Mrs Elizabeth Oluyomi	CNO, Family Planning Services	FMOH
Mrs Temitope Bombata	CNO, Family Planning Services	FMOH
Prof Oladapo Olayemi	HOD O&G Dept	UCH
Dr Adebola Roberts	Consultant O&G	UCH
Prof Adeyemi Adekunle	Consultant	
Dr Kayode Osungbade	Consultant	
Mr Aliyu Adamu	ACNO	Nursing&Midwifery Council
Dr Tony Udoh	ACHRO	FMOH
Dr Gabriel Ortonga	SMO1	FMOH
Dr C.O. Tetsola	FP Coordinator	Delta SMOH
Z.A. Otajele	Asst. FP Coordinator	Kogi SMOH
Dr George Udeji	Reproductive Health Coordinator	Imo SMOH
Mrs Stella Falaye	Family Planning Coordinator	Oyo SMOH
Mrs Idowu Okanlawon	Family Planning Coordinator	Lagos SMOH
Mr John Mboli	Director PHC	Taraba SMOH
Mrs Mariam Momoh	Family Planning Coordinator	FCT PHCB
Safiya Garba-Kaita	RH/FP Coordinator	Katsina State PHCB
Mrs S.B. Asaju	DDHE	Kwara SMOH
Dr Ibrahim Idris	Dep. Director, Public Health	Niger SMOH
Dr A. Olayemi	Head, RH Division	Kogi SMOH
Sarah Shaw	Advisor	MSI
Mr Effiom N. Effiom	Country Director	MSION
Mr Onoriode Ezire	Chief of Party, FH+	MSION
Dr Kingsley Odogwu	Director, Clinical Services	MSION
Dr Dawodu Adegoke	Family Planning Analyst	UNFPA
Mrs Titilola Opasina	Programme Coordinator	ARFH
Dr Adewole Adefalu	Programme Coordinator	ARFH
Dr Uwaila Akpan	Programme Manager (Family Planning)	CHAI
Zainab Saidu	Associate for Family Planning	CHAI
Dr Habeeb Salami	Programme Manager (FP)	Pathfinder International
Jerry Yem	FP Specialist	MSD
Mr Bright Orji	Director of Programmes	JHPIEGO
Mrs Hannatu Abdullahi	FP/RH&Gender Advisor	JHPIEGO
Dr Sada Dan Musa	Project Director	PALLADIUM
Dr Garba Rufai	SMO1	NPHCDA
Osikwemhe Peter	Scientific Officer	NPHCDA

Ohifeme Adeola	Asst Chief Scientific Officer	NPHCDA
Elizabeth Igharo	Director, Advocacy&Policy	JSI
Aishat Ejigbo	Strategic&Demand Planning	JSI
Dr Hameed Adediran	Consultant to FMOH	MSION
Amagbakhen Kenneth	Rapporteur	
Oreoluwa Ojo	Rapporteur	
Kayode Morenikeji	Programme Manager (RH)	USAID
Mrs H.A.T. Awotunde	PHC TUTOR	CHPRB
Dr S.K. Ahmadu	Clinical Advisor	IPAS
Rakiya Idris	Q.A. Senior Manager	SFH
Adejoke Oyewo	Q.A. SSO	NURHI
Stella Akinso	State Team Lead	NURHI
Mrs Ronke Atamewalen	Clinical Services Manager	MSION

# TABLE OF CONTENTS

<b>Foreword</b>	<b>2</b>
<b>Acknowledgement</b>	<b>3</b>
<b>Table of Contents</b>	<b>6-7</b>
<b>Acronyms</b>	<b>8</b>
<b>Course Overview</b>	<b>9</b>
▪ Introduction	
▪ Course Goal	
▪ Training Objectives	
<b>Module 1: Overview of Task Shifting/Sharing and Family Planning in Nigeria</b>	<b>10-22</b>
<b>Session 1: Overview of Task Shifting/Sharing Rationale for Task Shifting</b>	<b>11</b>
<b>Session 2: Overview of Family Planning in Nigeria</b>	<b>14</b>
<b>Module 2: Female Reproductive System</b>	<b>23-33</b>
<b>Session 1: Anatomy and Physiology of the Female Reproductive System</b>	<b>24</b>
<b>Session 2: Ovulation, Menstruation, Fertilization and Conception</b>	<b>28</b>
<b>Module 3: Introduction to Intrauterine Contraceptive Device (IUD) and Contraceptive Implants</b>	<b>32-41</b>
<b>Session 1: Product Profile and Medical Eligibility Criteria for CuT 380A and Medical Eligibility Criteria of IUDs</b>	<b>32</b>
<b>Session 2: Product Profile and Medical Eligibility Criteria for Jadelle<sup>R</sup>, Implanon<sup>R</sup> and Implanon NXR<sup>TM</sup> Product profile and Medical Eligibility Criteria for Cut 3480A and Medical Eligibility Criteriaa of IUDs</b>	<b>36</b>
<b>Module 4: Using Learning Guides during Model and Clinical Practice</b>	<b>42-59</b>
<b>Module 5: Insertion and Removal Techniques for IUD and Implants</b>	<b>60-103</b>
<b>Session 1: CuT 380A Insertion Techniques</b>	<b>60</b>

<b>Session 2: Jadelle<sup>R</sup> Implants Insertion Techniques</b>	<b>67</b>
<b>Session 3: Implanon<sup>R</sup> and Implanon NXT<sup>TM</sup> Insertion Techniques Implanon (classic) and Implanon NXT<sup>TM</sup> contraceptive implant insertion Techniques</b>	<b>76</b>
<b>Session 4: IUD CuT 380A Removal Techniques</b>	<b>91</b>
<b>Session 5: Implant (Jadelle<sup>R</sup>, Implanon<sup>R</sup> and Implanon NXT<sup>TM</sup>) Removal Techniques</b>	<b>94</b>
<b>Module 6: Model and Clinical Practice</b>	<b>104-109</b>
<b>Module 7: Counselling for IUDs and Implants</b>	<b>110-125</b>
<b>Session 1: Introduction to Counselling</b>	<b>111</b>
<b>Session 2: The Balanced Counselling Strategy</b>	<b>115</b>
<b>Module 8: Infection Prevention Practices during IUD and Implant Insertion and Removal Techniques</b>	<b>126-146</b>
<b>Session 1: Asepsis, Hand washing and Gloving</b>	<b>127</b>
<b>Session 2: Disinfection and Sterilization</b>	<b>135</b>
<b>Session 3: Disposal of Sharps and Waste</b>	<b>141</b>
<b>Module 9: Problem Management/Information and Support during IUD and Implant Use</b>	<b>147-155</b>
<b>Session 1: Problem Management during use of Copper-bearing IUDs</b>	<b>148</b>
<b>Session 2: Problem Management during use of contraceptive subdermal Implants</b>	<b>152</b>
<b>Module 10: Record Keeping, Management Information System (HMIS) and Contraceptive Logistics Management System (CLMS)</b>	<b>156 -165</b>
<b>Session 1: Record Keeping and Management Information System (MIS)</b>	<b>157</b>
<b>Session 2: Contraceptive Logistics Management System (CLMS)</b>	<b>161</b>

## ACRONYMS

AIDS	Acquired Immune Deficiency Syndrome
ANC	Antenatal Care
ART	Antiretroviral Therapy
ARV	Antiretroviral
BCS	Balanced Counselling Strategy
BCS+	Balanced Counselling Strategy Plus
CBO	Community Based Organization
CSO	Civil Society Organization
FMOH	Federal Ministry of Health
GON	Government of Nigeria
HCT	HIV Counselling and Testing
HIV	Human Immunodeficiency Virus
IEC	Information Education and Communication
LGA	Local Government Area
M&E	Monitoring and Evaluation
MIS	Management Information System
NACA	National Agency for the Control of AIDS
NDHS	Nigeria Demographic and Health Survey
NGO	Non-Governmental Organization
NPC	National Planning Commission
PLWHA	Persons Living with HIV and AIDS
PMTCT	Prevention of Mother to Child Transmission
RTI	Reproductive Tract Infections
SDP	Service Delivery Point
SOP	Standard Operating Procedure
STI	Sexually Transmitted Infection
SOPs	Standard Operating Procedures/Standards of Practice
VCT	Voluntary Counselling and Testing
WHO	World Health Organization



## **COURSE OVERVIEW**

### **TRAINING GOAL**

The overall goal of the training programme is to provide participants (Community Health Extension Workers) with necessary knowledge, attitude and skills to provide quality IUD and Implant services.

#### **Overall Objective:**

To develop the skills of service providers in the administration of long-acting reversible contraceptives (LARC)

#### **Specific Objectives:**

Specifically, by the end of the workshop, participants will be expected to be able to:

- Describe the mechanism of action, effectiveness and side effects of IUDs and implants
- Describe the essentials of client counselling and follow-up
- Demonstrate the preparation and care of the clients before, during, and after insertion and removal procedures.
- Demonstrate insertion and removal skills of IUD and implants using sterile techniques and following standard protocols;
- Insert 5 IUDs each using the standard protocol and remove 5 implants each using the standard protocol
- Demonstrate actions to be taken in the event of complications and procedures for follow up care;
- Describe the management skills needed to provide quality IUD and implant services.

## **MODULE ONE**

### **OVERVIEW OF TASK SHIFTING/SHARING AND FAMILY PLANNING IN NIGERIA**

**Session 1:** Overview of Task Shifting/Sharing

**Session 2:** Overview of Family Planning In Nigeria

## Module One - Session 1: Overview of Task Shifting/Sharing in Nigeria

### Learning Objectives:

At the end of the session, participants should be able to:

- Define Task Shifting
- Discuss three Rationales for Task Shifting
- Discuss three factors that facilitate the success of implementing Task Shifting

### Session Overview

- **Definition of Task Shifting**
- Rationales for Task Shifting
- Factors that facilitate the success of implementing Task Shifting

## CONTENT

### A. Introduction

- One of the major constraints to meeting the unmet family planning needs of women in their reproductive age is the shortage of healthcare providers and this is compounded either by lack of access to health facilities or unavailability of health services.
- As a solution to these identified problems, Task Shifting is one of the essential interventions identified to address these issues.
- This will not only increase utilization but also contraceptive prevalence which has remained low at 10%.
- It is pertinent to note that Family planning is an inexpensive and cost-effective intervention but health workforce shortages and restrictive policies on the roles of mid and lower-level cadres limit access to effective delivery of contraceptive methods in many settings.

### Definition of task shifting

- Task Shifting is the process whereby tasks are moved where appropriate to less specialized health workers.
- It is the process of enabling additional cadres of health workers to provide specific health intervention.
- Task shifting is defined in the WHO guidelines as *“the rational redistribution of clinical and other tasks among health care workers, according to their skills rather than their roles.”*

By re-organizing the workforce, Task Shifting presents a viable solution for:

- Improving health care coverage;
- Making more efficient use of human resources such as the CHEWs; and
- Strengthening the capacity of nurses, midwives and Community Health Officers to train the Community Health Extension Workers.

## **B. Rationale for Task Shifting**

- Expanding the task of providing contraceptive methods to other health worker cadres can significantly improve access to contraception.
- Many countries, for example in rural Kenya and Zambia have already enabled mid and lower-level cadres of health workers to deliver a range of contraceptive methods, utilizing these cadres either alone or as part of teams within communities and/or health care facilities.
- Based on the need to bridge the identified gaps of shortage of Family Planning service providers as well as increase access to the services and family planning facilities, there is need for adequate and equitable re-distribution of the health workforce to enable women access contraceptive services.
- The National Council on Health approved a recommendation from the Federal Ministry of Health to allow community health extension workers (CHEWs) to provide injectable contraception in the community/primary health care setting.

The rationale for Task Shifting is as a result of:

- Limited access to services by either overall shortage of health workers qualified to provide specific methods or their uneven distribution across a country or region;
- Difficulties in ensuring staff retention of higher cadres in certain settings such as rural areas;
- Lower salary levels of mid or lower-cadre health workers which can usefully reduce the budgetary cost of providing family planning services without compromising quality of service and client safety; and
- Availability of free time for the higher cadre health workers which would enable them to better focus on the provision of services requiring a higher level of technical proficiency.
- Task Shifting as an intervention will optimize the health workers' roles to improve access to key maternal, newborn and child health interventions.
- In the case of Family Planning, Task Shifting is a strategy for improving access to contraceptive methods, thus contributing to the achievement of health related MDGs especially MDGs 4 and 5, and the subsequent Sustainable Development Goals in Nigeria.

### **C. Factors that facilitate the success of implementing Task Shifting**

- Providing initial and on-going training for service providers, their supervisors and trainers.
- Supplying drugs and other Family Planning commodities;
- Providing Supportive Supervision;
- Establishing line of referral for other methods and management of complications and an effective follow-up mechanism for clients
- Ensuring that monitoring and evaluation systems are functional and effective

Health system arrangements and specific socio-cultural and political factors will shape the implementation of these recommendations in particular settings if appropriately planned, implemented and periodically evaluated.

### **Summary**

- The importance of Task-Shifting in Reproductive Health/Family Planning service delivery cannot be overemphasized.
- It has been widely accepted as an intervention critical to improving access to Reproductive Health/Family Planning services especially LARC method.
- The ongoing training will go a long way in meeting the Reproductive Health/Family Planning unmet needs of women especially those in hard to reach areas. Thus, contributing to increasing the contraceptive prevalence rate (CPR), and most importantly reducing maternal morbidity and mortality rate and improving the quality of life.

## **Module One Session 2: Overview of Family Planning in Nigeria**

**Time:** 1 hour

### **Learning Objectives:**

By the end of the session participants will be able to:

- Describe Nigeria's rapid population growth and the Age Structure of the population
- Discuss the trends in Nigeria's Fertility Rates and how they impact development
- Compare Nigeria's fertility rates with those of other countries
- Discuss the use of modern contraception in Nigeria
- Discuss the trends in Nigeria's Contraceptive Prevalence Rates (CPR)
- Classify the different types of modern contraceptive methods
- Discuss the barriers to the use of modern contraception in Nigeria

### **Session Overview**

- Nigeria's Rapid Population Growth and Age Structure of Nigeria's population
- Trends in Nigeria's Fertility Rates and how they impact development
- Comparing Nigeria's Fertility Rates with those of other countries
- Use of modern contraception in Nigeria
- Trends in Nigeria's Contraceptive Prevalence Rates (CPR)
- Classification of modern contraceptive methods
- Barriers to the use of modern contraception in Nigeria

### **Methods**

- Lecture
- Discussion
- Brainstorming

### **Materials**

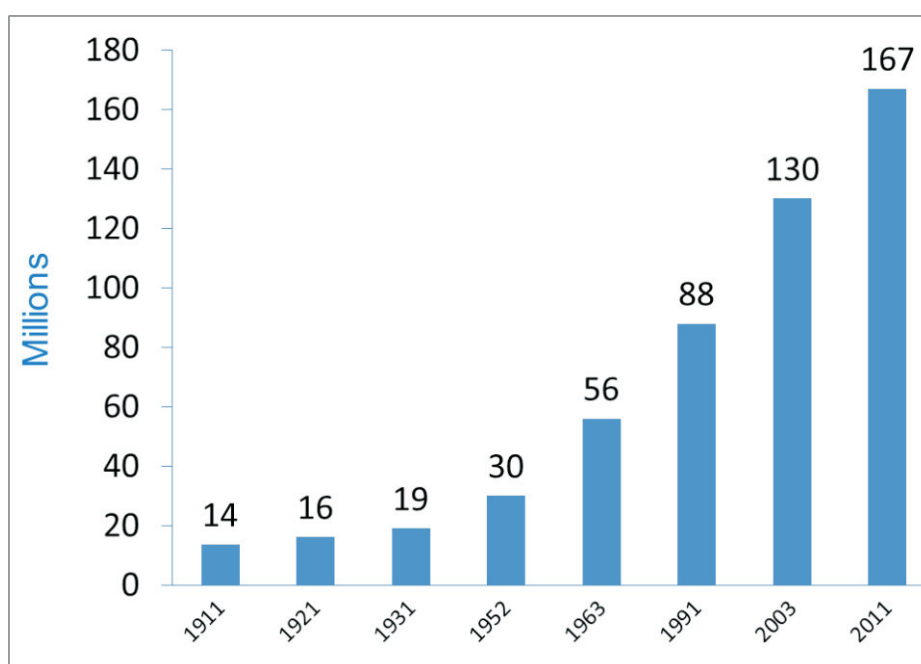
- Flip chart/Newsprint
- Markers
- LCD Projector and Laptop

## CONTENT

In the past four decades, Nigeria has made very bold efforts to achieve rapid economic development. However, amongst other factors, rapid population growth has affected the quality of life and made achievement of socio-economic development goals difficult.

### Nigeria's Population Growth

In 1963, both Nigeria and Britain had the same population size of 56 million. However in 2011, Nigeria's population stood at 167million while Britain was 62 million. Between 1963 and 2011 (48 years), Nigeria tripled its population and with sustained fertility of 5.7 and the growth rate of 3%, population will double in less than 24years.

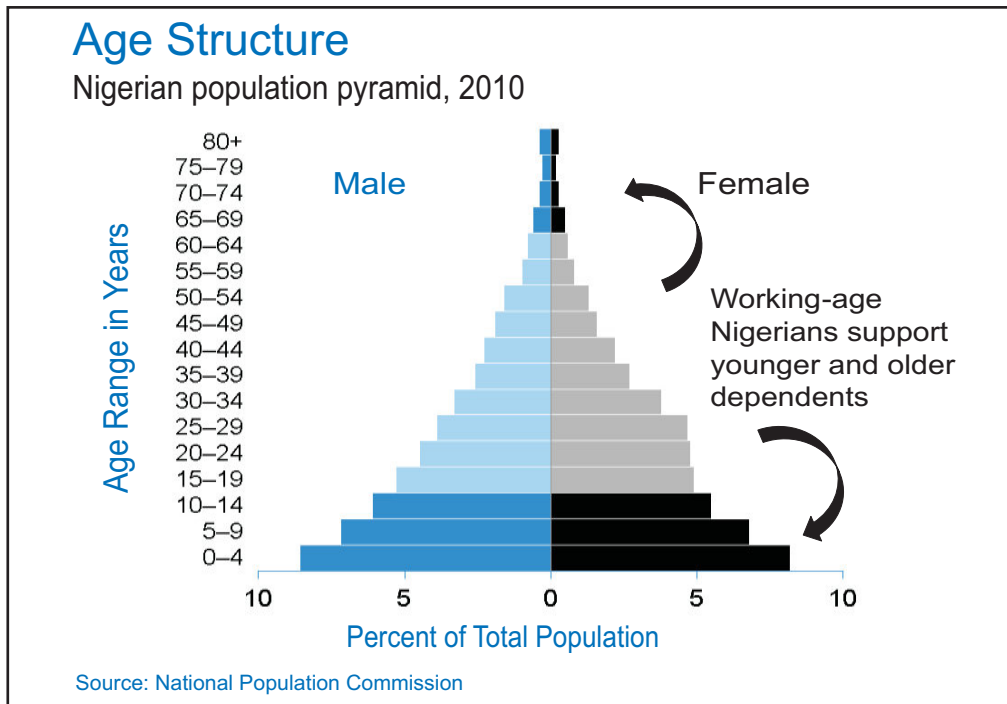


**Figure 1.1: Population of Nigeria – Rapid Growth**

Nigeria has a very youthful population which is not good for the country's economic development. Having fewer children will certainly help the economy. The darker bars at the bottom of the figure below represent Nigerian children ages zero through 14. The boys are on the left and the girls on the right. These are all children that the adults, in the middle, have to feed and educate. So, these are “dependents” and the adults are the working-age population. Our older citizens are also dependent, assuming they are not working, so they too need working-age people to support them.

Therefore, the ratio of people who are in the working-age to people who are too young or old to work (dependents) is low, about 1:4. That is, every working class person is feeding at least four mouths, and little is left to grow its economy, such as investing in economic activities, business, and more education.

**Figure 1.2: Age Structure of Nigeria's Population**



Nigeria Population Pyramid 2013

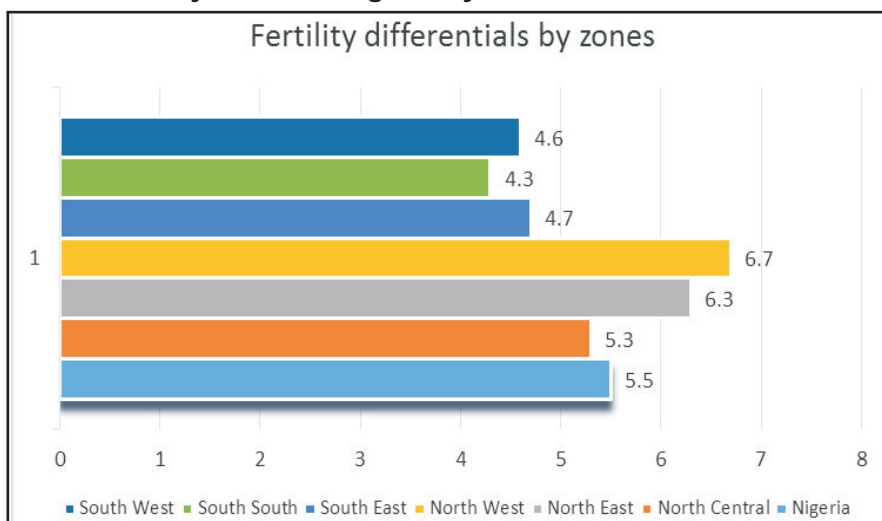
This implies that the more dependents a population has, the harder it is for it to grow its economy because all the money is spent on just trying to help these dependents to survive (feeding them, giving them the basics they need to survive). However, when there are fewer dependents (fewer children), then the working-age population can spend more money on other things like investments that make the economy grow.

**High Fertility Rates**

Nigeria has very high fertility compared with other nations, whether they are Christian, Muslim, wealthier or poorer, larger or smaller.

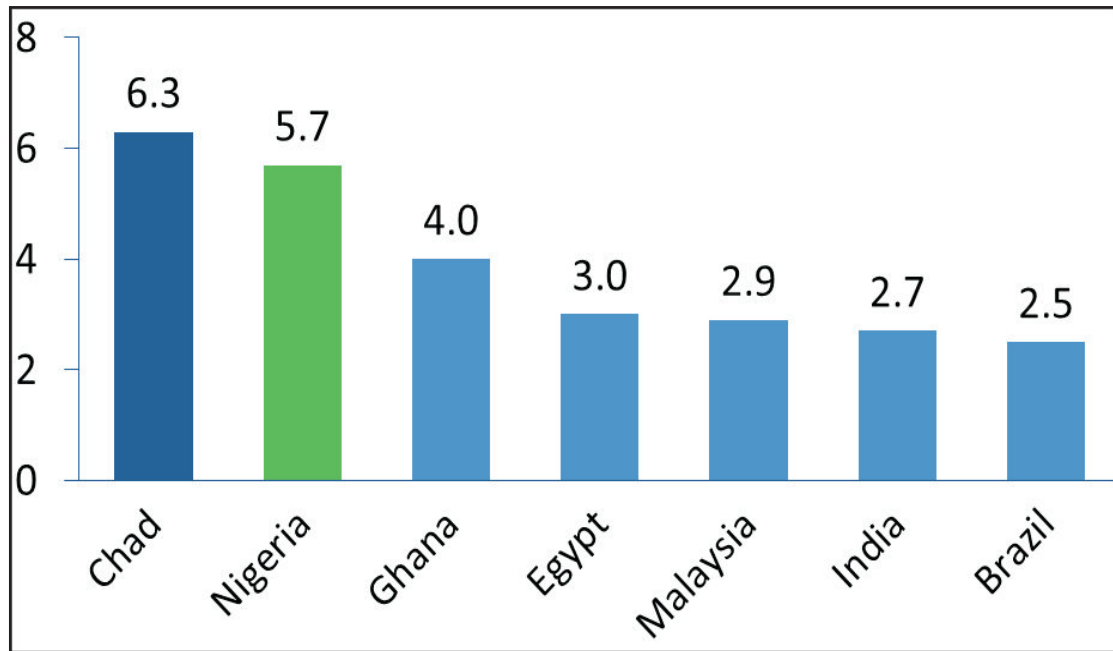
One main reason is the country's high fertility rate. When Nigeria is compared to a lot of countries – whether they are wealthier or poorer countries, Muslim or Christian countries, tiny countries or large countries – the fertility rate is high in comparison. Only a few nations, such as Chad, have higher fertility.

**Figure 1.3: Current Fertility Rates in Nigeria by Zones**

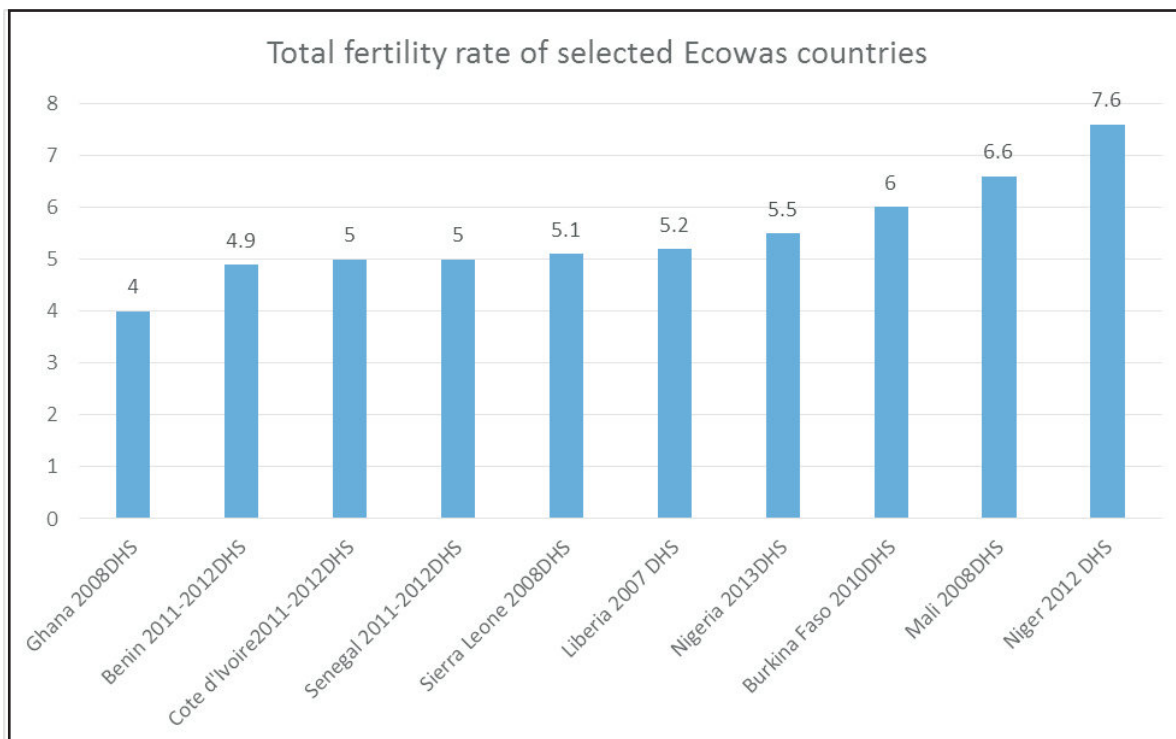




**Figure 1.4: Comparison of Nigeria's Fertility Rate with Other Countries**



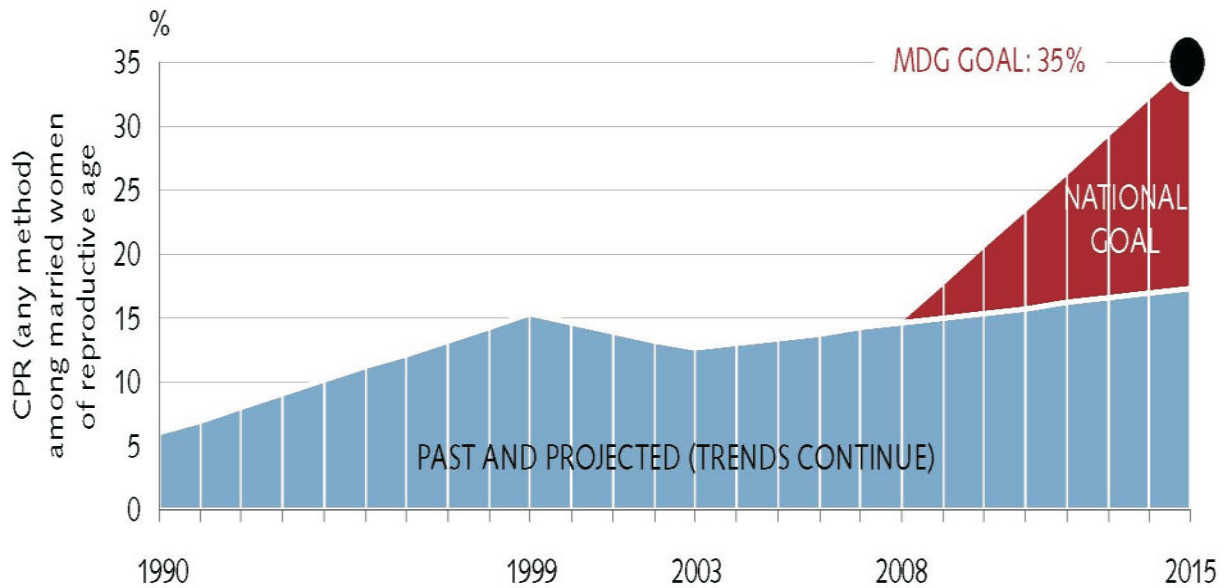
**Figure 1.5: Comparison of Nigeria's Fertility Rate with Other ECOWAS Countries**



**Use of Modern Contraceptives**

One main reason why fertility is high in Nigeria is the low use of modern contraceptives. Only 15% of our married women of childbearing age use modern contraception right now. In comparison, some of the other countries have up to 77% of married women using modern contraception. Can the country not afford to pay for modern contraception?

**Figure 1.6: Trends in Contraceptive Prevalence Rates**



**Sources:** 1998, 2000, 2003, 2008 and 2013 Demographic and Health Surveys, Reality projections for intervening and future years

Family Planning is an important health measure contributing to the health of women, children and men. A common view, albeit rather narrow, held by most people is that family planning is associated with the use of contraceptives to limit family size. Used in a less specific sense, family planning helps everyone. Family planning:

- helps women to protect themselves from unwanted pregnancies;
- saves the lives of children by helping women space births;
- helps men - and women – care for their family;
- improves family wellbeing;
- helps the nation develop,
- Gives everyone a better opportunity for a good life.

### How Fertility Impacts Development

Fertility decline helps many families out of poverty. (UNFPA: “Slower population growth has encouraged overall economic growth in developing countries”)

It is known that fertility can relate to development because if families have fewer children per woman, then they have fewer mouths to feed. At the family level, having fewer mouths to feed could help to reduce poverty and free more money to educate or help each child. And many analysts, including UNFPA analysts, have done research that shows slower population growth also reduces poverty at the national level.

Summarizing these studies, the *State of World Population 2002* report by the United Nations Population Fund makes the observation that “slower population growth has encouraged overall economic growth in developing countries.

Nigeria can learn from East Asia. When they lowered fertility, they experienced incredibly fast development. Around 1960, the development indicators in many East Asian countries were very close to what they are in much of sub-Saharan Africa today. The gross domestic product per capita was low and fertility and population growth rates were high. Many international observers didn't see how the Asian countries were going to escape poverty.

In Thailand, from the 1960s to the 1990s, fertility levels fell from a little bit higher than where Nigeria is today down to 2.3 births per woman. And during those same years, the GDP per capita was rising very fast. This is not a coincidence. Thailand's drop in fertility helped to free up resources, which, when properly invested, contributed to rapid economic growth.

In economic terms, fertility decline and thus slower population growth creates:

- The potential to increase the rate of economic growth
- A path out of poverty for many families

At the family level, when parents have fewer children, they can focus on the quality of each child's education, nutrition, or other aspects of life. Each child can have more educational and other opportunities, as there are fewer dependent children per working adult. If there are fewer dependents per working adult, then more money can be saved and invested in things like modern agriculture.

### **Education**

In the education sector, if Nigeria continues on its current path of high fertility, the number of students that will enter primary schools will increase - more than double by 2040. How shall the nation take care of these students? If the country takes the path of low fertility, the number of students entering primary school won't rise as quickly, making the number of students more manageable. And if the nation has fewer students under the Low Fertility Scenario, there will be less pressure to build new schools.

### **Health**

Fertility affects health mainly because certain types of births are exceptionally risky. "Risky births" are defined as births that are too closely spaced, too young or too old, or when the mother has too many children. All of these could cause death or injury to the mother and child. In Nigeria, more than 6 in 10 births fall in at least one of the high risk categories. In Nigeria, this means that more than half the children born have an elevated risk of dying before their 5<sup>th</sup> birthday. This risk could be significantly diminished by using child spacing to avoid births that are too closely spaced or that fall into other high-risk categories.

Lower fertility also puts less strain on the nation's healthcare system and health workers, including nurses/midwives and CHEWs. At present, the country does not have adequate health workers, especially midwives. The number of midwives required would increase faster under the High Fertility Scenario. But under the Low Fertility Scenario, the number of midwives required would increase more slowly.

The same is true for hospitals. Nigeria may need more hospitals to care for even its current population, but under rapid population growth, it will need even more hospitals, not just for child birth but for other medical necessities as well. By the current estimates, even to just maintain current standards of care, the number of hospitals required in Nigeria would more than double between now and 2040 if the nation continues at high fertility. But if it is able to lower fertility, then the number of hospitals required will not increase as much, and the challenge will be easier to manage. By 2040, Nigeria could save 47 billion Naira in health expenditures under the Low Fertility Scenario.

In summary, lower fertility in Nigeria just in the next 10 years could help us avert 1.5 million child deaths. It could help us save 31,000 women's lives, reduce health complications for mothers and children, and reduce stress on the national budgets and medical staff.

## **Agriculture**

Nigeria strives for a productive agricultural sector and wants to conserve natural resources for sustainable development. In the agricultural sector, as in other sectors, lower fertility yields benefits for Nigeria. Nigeria has become a rice-eating country. Under the High Fertility Scenario, more people are eating rice - 1.8 billion metric tons by 2040. Where is this rice going to come from? This is a question for national security—whether the country can feed the number of people it has. Nigeria is already importing some rice. If the country pursues a Low Fertility Scenario, the rice needed could be reduced by 400 million metric tons per year by 2040. This would also mean less money needed to pay for rice imports.

## **Economy**

The national development policy is to become a modern and prosperous country over the next 30 years. The economy can benefit in many ways from slower population growth. If it is assumed that Nigeria's real GDP grows at 6 percent each year, then under the High Fertility Scenario, each Nigerian's average GDP will not grow very fast. Annual GDP per capita will only grow to 748,000 Naira per person by 2040. But if there are fewer people, the nation can invest more in them, and spread the wealth among fewer people, GDP per person would grow faster.

If Nigeria has lower fertility, it will also need fewer jobs because there will be fewer teenagers that are growing up and looking for jobs. In the High Fertility Scenario, the number of additional jobs that Nigeria needs each year will grow so fast that it is probably impossible to keep up. These new job seekers will have nothing to look forward to, no hope. And under the Lower Fertility Scenario it still is an incredible challenge to try to generate enough jobs for these teenagers who are growing up and entering the workforce, but at least it's a lot more manageable. There will be fewer new job seekers and better security.

## **CLASSIFICATION OF MODERN FAMILY PLANNING METHODS**

### **A. HORMONAL CONTRACEPTIVES**

#### ***Oral Pills***

- Combined pills
- Progestin-only pills

#### ***Vaginal Pills***

- Combined pills – intermittent or continuous

#### ***Emergency Contraceptive Pills***

- Postinor 2

#### ***Injectables***

- Combined injectables, e.g. Norigynon
- Progestin-only injectables, e.g. Depot Medroxy-progesterone acetate (DMPA) or Norethisterone enanthate (NET-EN)

#### ***Implants***

- Biodegradable implants
- Non-biodegradable implants, e.g. Jadelle, Zarin and Implanon

**B. INTRA-UTERINE CONTRACEPTIVE DEVICES (IUD)**

- Copper T 380A.
- Minera

**C. BARRIER METHODS**

- Male Condom
- Female Condom e.g. Femshield
- Diaphragms
- Cervical caps

**D. VOLUNTARY SURGICAL CONTRACEPTION**

- Bilateral tubal occlusion
- Vasectomy

**E. NATURAL FAMILY PLANNING METHODS**

- Lactational amenorrhoea method (LAM)
- Cervical mucus or Billings Ovulation Method
- Calendar (rhythm) method
- Sympto-thermal method

**F. IMMUNOLOGICAL METHODS**

- Anti- HCG Vaccine
- LH/RH Vaccine

**G. OTHERS**

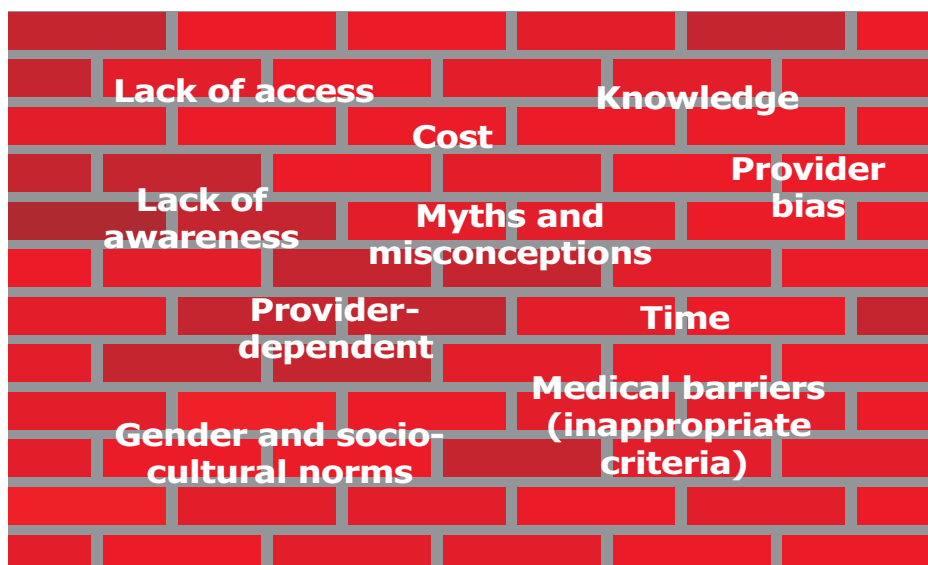
- Gossypol

The wide choice of family planning methods now available allows health programmes to offer an appropriate method to each individual. Most modern contraceptive methods are virtually without risk and in addition, offer substantial benefits besides preventing pregnancies. The methods most often used to avoid closely spaced pregnancies or pregnancies at a young age are oral contraceptives, barrier methods and spermicides, emergency contraceptive pills (ECPs) and natural family planning methods. Intra-uterine devices (IUDs), injectables and implants are longer acting methods, and may be preferred by older women or those who already have all the children they want. Since voluntary surgical contraception is generally permanent, it is inappropriate for couples who want more children.

**Barriers to the Use of Contraceptive Methods in Nigeria**

Family Planning clients are often restricted by the choice of methods offered to them, or are deterred from using contraception due to the side effects related to use of available methods. Other barriers include lack of access, lack of knowledge and awareness and provider bias. Some methods are provider-dependent and are not under the control of the client. In addition, myths and misconception, inappropriate criteria, gender and socio-cultural norms and inappropriate clinic hours also constitute major barriers to the use of contraceptives.

**Figure 1.7: Barriers to the Use of Contraception in Nigeria**



## **SUMMARY**

The National Population Policy recognized the adverse effect of rapidly growing population on the quality of life, development and security, hence, the Federal Government, in partnership with donor agencies, have intensified effort to ensure that Nigerian couples have access to free contraceptive commodities.

Nigeria seeks better jobs, food security, better health and education for its people. The nation wants wealthier people (higher per capita GDP) and a better quality of life. And to do that, the Nigerian people need to advocate for support for family planning at the state, local, and community levels, and expand access to family planning commodities

Meeting the contraceptive needs of women generally is an important component of comprehensive maternal and child health services. To assist women who want to prevent or delay pregnancies, programmes should offer family planning information and services. Careful counselling can help women to choose methods that are safe, effective and convenient - methods that best meet their short and long term family planning needs.

Well-designed family planning programmes provide services that women require both before and after their babies are born. When women's reproductive health needs are met, they have greater chance of not dying from childbirth and healthier families.

## **EVALUATION**

- ◆ Mention how Nigeria's high Fertility Rates has impacted on its development
- ◆ Discuss the trends in Nigeria's Contraceptive Prevalence Rates (CPR)
- ◆ Mention the different types of modern contraceptive methods
- ◆ What are the barriers to the use of modern contraception in Nigeria

## **MODULE TWO**

### **FEMALE REPRODUCTIVE SYSTEM**

**Session 1:** Anatomy and Physiology of the Female Reproductive System

**Session 2:** Ovulation, Menstruation, Fertilization and Conception

## Module Two: Session 1: Anatomy and Physiology of the Female Reproductive System

### Learning Objectives:

***By the end of this session, the participants should be able to:***

- Identify on a diagram the names of the external and internal organs of the female reproductive system
- Mention the functions of each of the female reproductive organs

### Session Overview

- Introduction
- External Female Reproductive Organs
- Internal Female Reproductive Organs

## CONTENT

### A. Introduction

The female reproductive system is the part of a woman responsible for producing a baby.

The system consists of two parts:

- The external female reproductive organs
- The internal female reproductive organs

### B. The External Female Reproductive Organs

*Mons pubis (Fatty pad)*

- This is spread over the pubic bone and becomes covered with hair at puberty.
- It protects the external organs

*Labia majora (Big lips)*

- These are two thick outer lips immediately below the fatty pad.
- They protect the vagina

*Labia minora (Small lips)*

- These are two thin soft inner lips, pinkish in colour and very sensitive.
- They cover and protect the opening of the urine tube (urethra) and the opening to the inner body (vagina).

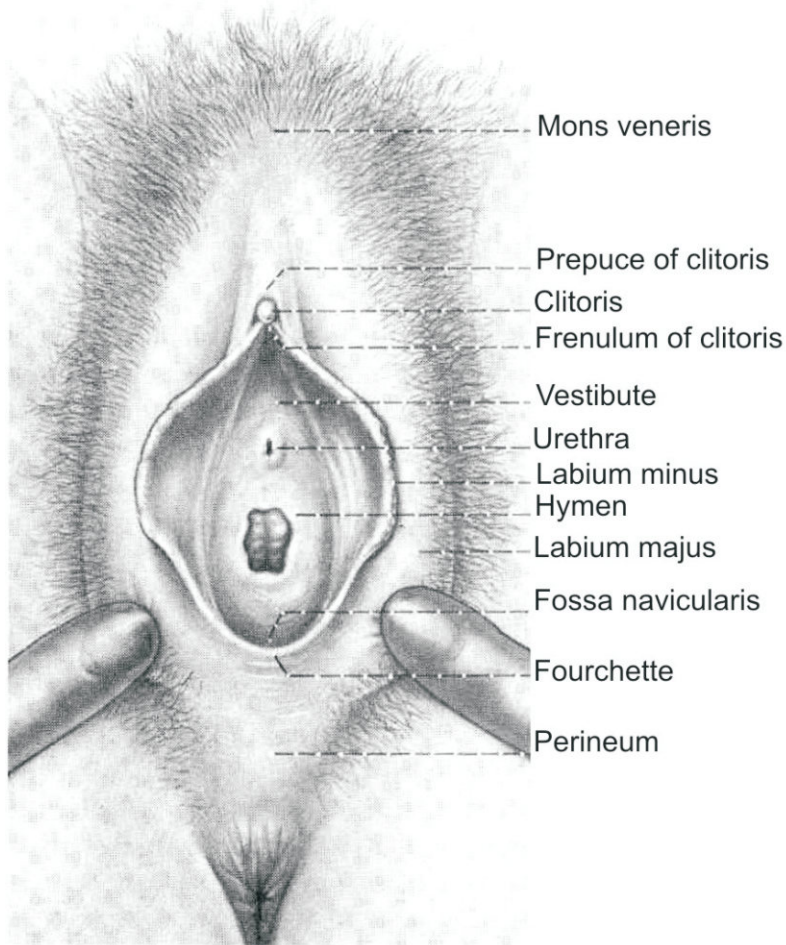
*Clitoris*

- The clitoris lies between the upper part of the big and small lips, just above the opening of the inner body (vagina)
- It is the most sensitive part of a woman and responds to sexual stimulation
- This is the part that is erroneously cut and removed during female circumcision (genital mutilation/genital cutting).
- It is the centre of female sexual excitement

- ◆ The trainer requests a participant to come forward and repeats the process.



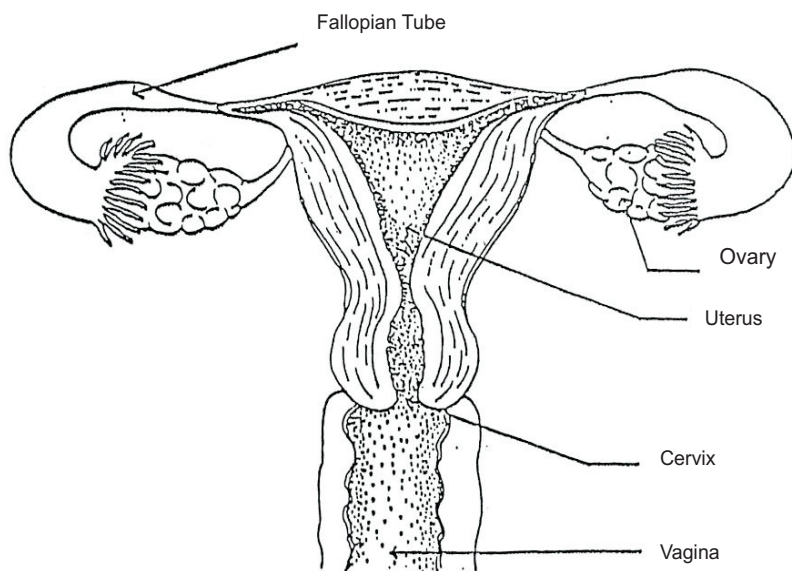
**Figure 2.1.1: The Female External Reproductive Organs**



### **C. Internal Female Reproductive Organs**

- ◆ The Trainer explains that the internal organs cannot be seen.
- ◆ S/he displays the diagram of the internal organs of the female reproductive system, naming each organ and describing its function as follows:

**Figure 2: The Female Internal Reproductive Organs (Internal Genitalia)**



### *Vagina (Opening to the inner body)*

- It is the opening to the mouth of the womb (cervix) and other reproductive organs.
- It serves as an outlet for menstruation
- It holds the penis during intercourse
- It serves as a passage for the baby
- It also serves as a route for drug administration.

### *Bartholin's gland (Lubricator of vagina)*

- These are two small glands situated under the big lips of the vagina
- They release drops of lubricant into the small lips when a woman is sexually stimulated and this prevents friction and discomfort during sexual intercourse.

### *Hymen*

- This is thin membrane that covers the vagina when a girl is a virgin but is torn during first exposure to sexual intercourse (the process may be painful and may cause bleeding). The hymen may also be torn during vigorous exercise or use of tampons.
- It protects the vagina from infection before puberty.

### *Urethra (Urine carrying tube)*

- This is the opening situated between the vagina and the clitoris
- It serves as a passage for urine.

### *Cervix (Mouth of the womb)*

- The cervix is the mouth of the womb that protrudes into the vagina. In a non-pregnant woman, it feels like the tip of the nose when touched.
- It opens up (dilates) during labour to allow the baby to be delivered (born)
- It is the passage for menstruation
- It produce a secretion (mucus) which helps the sperm to move
- It is the passage through which the IUD is placed into the womb.

### *Womb*

- The womb is a bigger sac that lies in the pelvic cavity behind the bladder and in front of the rectum.
- It accommodates and protects the fertilized egg that gets implanted there until it is fully developed into a baby and delivered
- During labour, it helps to push the baby out
- It is the place where an IUD, a family planning method, is placed.

### *Fallopian tubes (Egg carrying tubes)*

- They are two in number and are located on each side of the womb near the top (fundus) of the egg bag. Each has a finger-like structure (fimbria) at both ends to assist in drawing the ripe egg into the Fallopian tube.
- It serves as a meeting place for the male's seed and the female egg.
- It serves as a place for the male's seed and female's egg to unite (fertilization).
- It serves as the passage for the united egg and sperm (fertilized egg) to move to the womb
- It serves as a passage for the united egg (fertilized egg) to move to the womb.

### *Ovaries (Egg bags)*

- They are two small egg-shaped bags on each side of the egg-carrying tube (Fallopian tube)
- They produce ripe eggs once a month.
- They produce the female sex hormone that make a woman look like a female and keep the reproductive system in good order

### *Ovum (Egg)*

- This is the female sex cell. It is about the size of a pinhead.
- A ripe egg released each month into the egg carrying tube (Fallopian tube) for fertilization by the male's seed. If not fertilized, it dissolves and is absorbed into the uterus and comes out with the menstrual blood.

## **Module Two: Session 2: Ovulation, Menstruation and Fertilization/Conception**

### **Learning Objectives:**

By the end of this session, the participants should be able to:

- Explain the meaning of ovulation
- Understand how ovulation occurs
- Explain what menstruation is
- Discuss the type of health education necessary during menstruation
- Describe the process of fertilization and conception

### **Session Overview**

- Introduction
- Ovulation
- Definition of menstruation
- Fertilization/Conception
- Definition of fertilization
- Process of fertilization
- Implantation

## **CONTENT**

### **A. Introduction**

This session addresses the topics of ovulation, menstruation and fertilization/conception

### **B. Ovulation**

- The Trainer asks the participants to discuss how ovulation happens and how it is related to menstruation.
- S/he notes the responses on a flip chart and clarifies by illustrating with a diagram of a female reproductive organs as follows:

#### *Ovulation*

- Ovulation is the release of a mature egg from the ovaries (egg bags) into the Fallopian tubes (egg tubes).
- It usually happens once every month after a girl reaches puberty.
- This period is known as the fertile period, when a woman can become pregnant if she has sexual intercourse.
- Ovulation usually occurs 14 days before a woman sees her next menses. Therefore, in women with a 28 days cycle, ovulation occurs in the middle of the menstrual cycle.

### **C. Definition of Menstruation**

- Menstruation is the process whereby the lining of the womb that has prepared itself to welcome a fertilized egg peels off or sheds off because fertilization has not occurred.
- This results in the flow of blood through the vagina.
- The flow of blood is referred to as menstruation or “period”.

When menstruation begins:

- Menstruation normally starts when a girl reaches between 10 and 14 years of age.
- Menstruation occurs every 21 to 35 days and lasts 3 to 7 days.

#### D. Menstrual Process and Cycle

*28 day menstrual cycle*

The events in a 28 days menstrual cycle are as follows:

Day 1 – 5

- Menstrual bleeding occurs. This normally lasts for 3 to 7 days. The first day of menstrual period is referred to as “day 1” of the menstrual cycle.

Day 5 – 7

- Each month after the last bleeding, the body begins to produce secretions (hormones) which help the eggs in the egg-bag to begin to grow.

Day 7 – 11

- The lining of the womb starts to build up to receive the female's egg in case it is united with the male seed (sperm).

Day 11 – 14

- A ripe egg is released from the ovary. This is known as ovulation.

Day 14 – 21

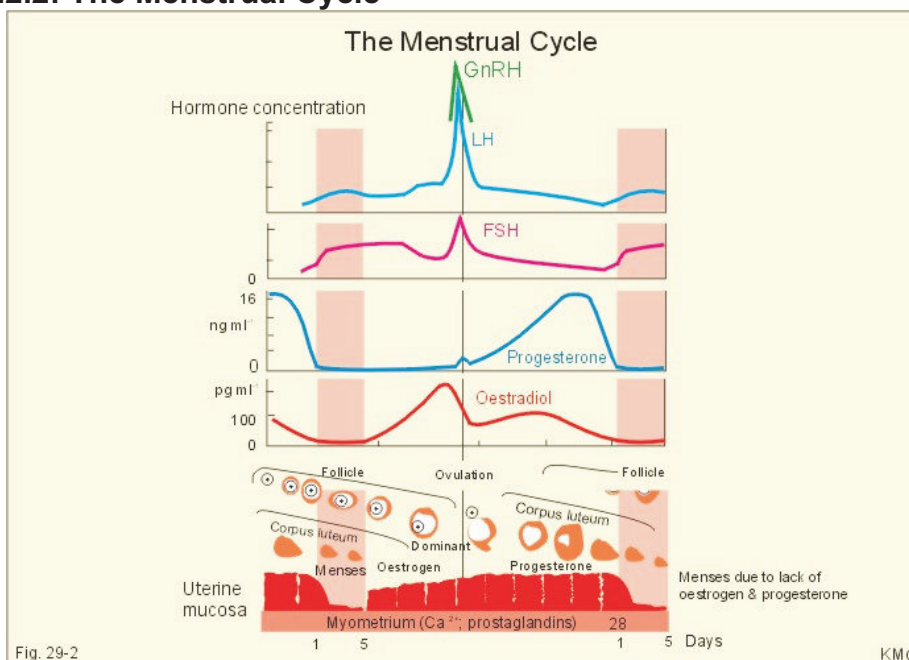
- The released ripe egg moves to the egg-carrying tube (Fallopian tube). The body makes sure that the lining of the womb is nourished and filled with blood to ensure that the fertilized egg survives.

Day 21 – 28

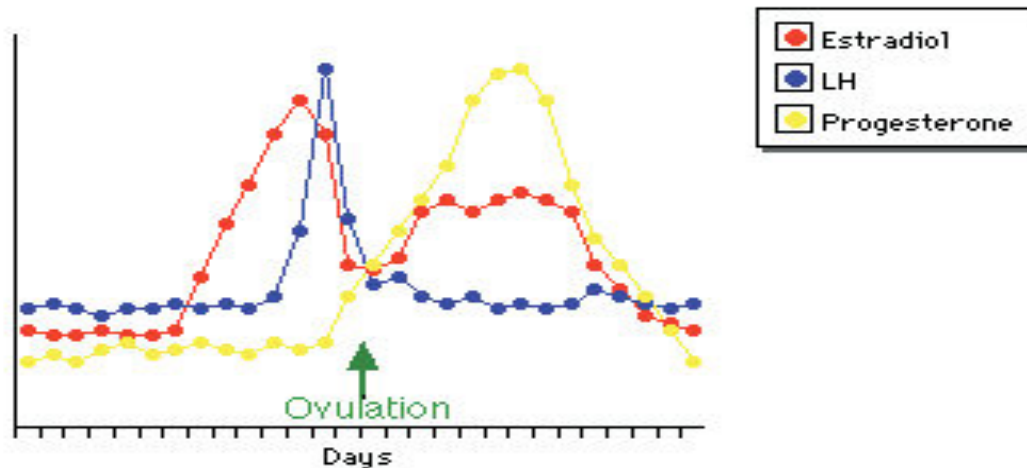
- If the male seed (sperm) fails to reach and unite with the female egg, the prepared lining of the womb will start peeling or shedding off.

At the end of the cycle, this shedding comes in the form of blood called “period” or menstruation. When this happens, a new cycle starts.

**Figure 2.2.2: The Menstrual Cycle**



**Figure 2.2.2: Hormonal Factors in Ovulation**



### **E. Process of Fertilization**

- ◆ The Trainer describes the process of fertilization illustrating with the diagram below:

#### *Step 1:*

- Every 14<sup>th</sup> day (of a 28 days cycle) in the month, when ovulation occurs, a ripe egg leaves one of the ovaries where thousands of eggs are stored.
- The ripe egg moves into the fallopian tube (egg-carrying tube) to wait for the male seed (sperm).

#### *Step 2:*

- Likewise, the man's seed (sperm) that is produced by the testes gets released in millions into the male seed carrying tube (vas deferens).
- During intercourse, the man ejaculates and deposits his seeds into the vagina.

#### *Step 3:*

- The male seed (sperm) which is very active and fast, swims through the mouth of the womb (cervix) into the womb (uterus).
- If intercourse occurs during or near the time of ovulation when a ripe egg is ready and live sperm meets a ripe egg in one of the tubes, fertilization occurs.
- This can happen within 1 hour to 1 hour 30 minutes after ejaculation.
- The male's seed or female egg may also arrive in the Fallopian tube to await each other. The sperm has an average life span of 2 to 3 days (48 – 72 hours) to fertilize the female egg within the woman's body.
- Likewise, the ovum (female egg) can only survive for 40 hours after ovulation.
- Therefore, fertilization can only occur if a woman has sexual intercourse during the period of ovulation (peri-ovulatory period, i.e., two to three days before ovulation or one to two days after ovulation)
- If fertilization fails to happen, the egg is absorbed into the body

#### *Step 4:*

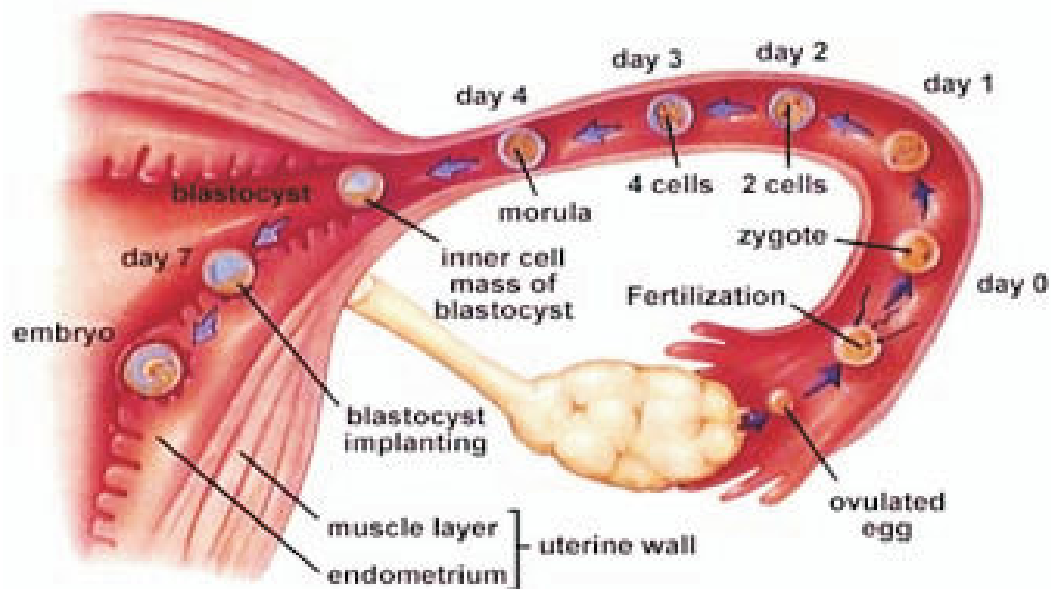
- Fertilization then occurs. A single sperm is usually responsible for fertilizing the female egg
- If fertilization fails to happen, the egg is absorbed into the body.

## F. Implantation

Implantation of the fertilized egg occur when it attaches itself to the upper part of the uterus (womb).

- The attached fertilized egg now develops inside the womb for the next 40 weeks until it is delivered as a baby.

**Figure 2.2.3: The Process of Implantation**



### Summary/Evaluation

- ◆ The Trainer requests participants to answer the following questions:
  - What is ovulation?
  - Describe how it occurs.
  - What is menstruation?
  - What is fertilization?
  - Explain how pregnancy occurs.

## Module Three Session 1: Product Profile of CuT 380A and Medical Eligibility Criteria for IUDs

### Learning Objectives:

*By the end of this session, the participants should be able to:*

- Define the Intrauterine Contraceptive Device (IUD) and classify the types available;
- Mention the mechanism of action, effectiveness, advantages and the disadvantages
- Discuss the Medical Eligibility Criteria for use of IUDs

### Session Overview

- Definition of the IUD
- Classification of the types available
- Mechanism of action, effectiveness, advantages and disadvantages
- Medical Eligibility Criteria for use of IUDs

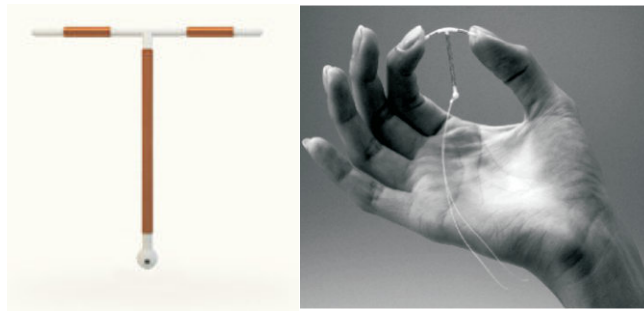
## CONTENT

### A. Introduction

#### Definition of the IUD and Classification of the types available

- IUDs are “small flexible devices made of metal and/or plastic that can prevent pregnancy when inserted into a woman's uterus through her vagina.”
- The types IUDs available in Nigeria include:
  - (a) Copper T 380A IUD (CuT 380A)
  - (b) Levonogestrel Intrauterine System (Mirena),

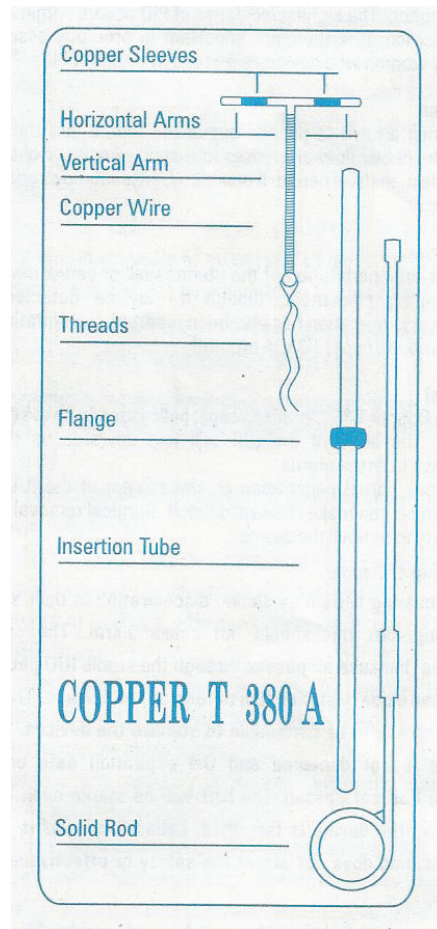
**Figure 3.1.1: CuT 380A**



- A T-shaped intrauterine device (IUD), measuring 32 mm horizontally and 36 mm vertically, with a 3 mm diameter bulb at the tip of the vertical stem.
- A thread is tied through the tip, resulting in two white threads, each at least 10.5 cm in length, to aid in detection and removal of the device.
- The T-frame is made of materials which aid in detecting the device under x-ray.



**Figure 3.1.2: Presentation in the package**



- Cu T 380A also contains copper: approximately 176 mg of wire coiled along the vertical stem and a 68.7 mg collar on each side of the horizontal arm.
- The total exposed copper surface area is  $380 \pm 23 \text{ mm}^2$ . One unit weighs less than 1g.
- Each Cu T 380A is packaged together with an insertion tube and solid white rod in a sterilized pouch.
- A moveable flange on the insertion tube aids in gauging the depth of insertion through the cervical canal and into the uterine cavity.

## **B. Mechanism of action, effectiveness, advantages and the disadvantages**

### ***Mechanism of Action of Cu T 380A***

- The mechanism remains unknown.
- Possible mechanism(s) by which copper enhances contraceptive efficacy include interference with sperm transport or fertilization
- Prevention of implantation.
- The contraceptive effectiveness of Cu T 380A is enhanced by copper continuously released into the uterine cavity.

## **Effectiveness**

Less than one pregnancy occurs per 100 women using an IUD over the first year (6–8 per 1,000 women). Over 10 years of IUD use: about 2 pregnancies per 100 women.

## **Advantages of CuT 380 A-bearing IUDs**

- IUDs are highly effective and safe for majority of women
- They are reversible
- They are independent of intercourse
- They are private
- No day-to-day action is required
- IUDs are easily available
- They have no effect on lactation
- There is no drug interaction
- May help protect from endometrial cancer
- They are long-acting (Cu-T-380A is effective for as long as 12 years)

## **Disadvantages of CuT 380 A IUDs**

- Have common side effects (usually diminish after the first three months of use)
  - prolonged and heavy monthly periods
  - irregular bleeding
  - more cramps and pain during monthly bleeding
  - IUDs do not protect against STIs/HIV
  - They require trained provider to insert and remove
- Complications are rare, but may occur:
  - expulsion of IUD which may lead to pregnancy
  - uterine perforation
  - PID (if inserted in woman with current gonorrhoea or chlamydia)

## **C. Medical Eligibility Criteria for the use of IUDs**

- The WHO MEC is described as:

**“A document that reviews the medical eligibility criteria for use of contraception, offering guidance on the safety of use of different methods for women and men with specific characteristics or known medical conditions.”**

**There are four categories:**

- *WHO Category 1:* Women who can use IUDs without restriction
- *WHO Category 2:* Women who can generally use IUDs; some follow up may be needed
- *WHO Category 3:* Use of IUDs is not recommended in these women
- *WHO Category 4:* Women who should not use IUDs.

Category	Description	When clinical judgment is available
1.	No restriction to use	Use method under any circumstance
2.	Benefits generally outweigh the risks	Generally use the method
3.	Risks generally outweigh the benefits	Use of the method not usually recommended except if other methods are unavailable/unacceptable
4.	Unacceptable health risks	Method not to be used

### *How to select contraceptive method using WHO MEC for IUDs*

#### *Women who can use IUDs without restriction (WHO Category 1)*

Women who:

- are 20 years or older
- have had children
- are within the first 48 hours postpartum
- are more than 4 weeks postpartum, regardless of breastfeeding status
- have past ectopic pregnancy
- have hypertension
- have deep vein thrombosis (DVT)
- have current or history of cardiovascular disease:
  - stroke
  - ischemic heart disease
  - multiple risk factors
- have lupus
- have headaches (migrainous and non-migrainous)
- have diabetes
- have any type of liver disease: tumour or hepatitis
- take certain drugs – anti-tuberculosis drugs e.g. (rifampicin, rifambutin), anti-convulsants (e.g. Phenytoin) or anti-retroviral agents (e.g. ritonavir)
- are obese
- have uterine fibroids (without distortion of uterine cavity)
- have cervical ectopy
- have current breast cancer
- have cervical intra epithelial neoplasm (CIN)
- have past pelvic inflammatory disease with subsequent pregnancy
- smoke irrespective of age
- had first trimester abortion (no sepsis)

#### **D. Summary**

- Intrauterine contraceptive devices are effective and reversible contraceptive methods that are acceptable to many women in Nigeria.
- Cu T380A is the current copper-bearing IUD being used in Nigeria.
- Most side effects and other health problems associated with the use of IUDs are not serious.
- Changes in the menstrual bleeding pattern, especially some increase in the amount and duration of menstrual bleeding, are the most common adverse effects.

## Module Three Session 2: Product Profile of Contraceptive Implants and Medical

### Eligibility Criteria for Implants

#### Learning Objectives:

- Describe the types, characteristics, effectiveness and mechanism of action of implants
- List the advantages and disadvantages of contraceptive implants
- Mention the special characteristics of Jadelle<sup>®</sup>, Implanon<sup>®</sup> and Implanon NXT<sup>™</sup>
- Discuss the MEC for Implant use
- Observe the insertion and removal of Jadelle<sup>®</sup> and Implanon<sup>®</sup> on video

#### Session Overview

- Types, characteristics, effectiveness and mechanism of action of implants
- Advantages and disadvantages of contraceptive implants
- Special characteristics of Jadelle<sup>®</sup>, Implanon<sup>®</sup> and Implanon NXT<sup>™</sup>
- Medical Eligibility Criteria for Implant use
- Video of insertion and removal of Jadelle<sup>®</sup>, Implanon<sup>®</sup> and Implanon NXT<sup>™</sup>

### CONTENT

#### A. Introduction:

#### Types, characteristics, effectiveness and mechanism of action of implants;

- Contraceptive implants are progestin-only contraceptives inserted under the skin of a woman's upper arm by a minor surgical procedure.
- A blood level of the progestin sufficient to prevent conception is reached within a few hours after placement of the implants and is maintained at an effective level for at least three to five years.

#### *Types of Contraceptive Implants*

- Jadelle<sup>®</sup> — two silicon rods; each containing 75 mg levonorgestrel. It is an improved version of Norplant. Jadelle is effective for 5 years.
- Implanon<sup>®</sup> —one rod containing a progestin called etonogestrel. Implanon<sup>®</sup> is effective for 3 years.
- Norplant<sup>®</sup> — six soft plastic rods that each contain 36 mg levonorgestrel. Effective for 5-7 years. **Norplant has been discontinued due to the availability of newer and better implants, but there are still women using it who will be due for removal over the next few years.**

#### *Product Profile of Jadelle<sup>®</sup>*

Jadelle<sup>®</sup> is:

- An implant system that provides effective, long-acting, reversible contraception for women.
- Two thin, flexible rods made of silicone tubing and filled with levonorgestrel, a synthetic progestin, are inserted just under the skin of a woman's upper inner arm in a minor surgical procedure.

**Figure 3.2.1: The Jadelle® Implant**



- Protection from pregnancy is provided within 24 hours, when insertion is performed during the first week of a woman's menstrual cycle.
- The woman rapidly returns to her normal fertility when the implants are removed. Since Jadelle® does not contain estrogen; the most common side effects are changes in menstrual bleeding patterns.
- Most other common side effects are similar to those experienced by women who use other hormonal contraceptives.
- The outer part of the Jadelle® rod is silicone rubber tubing, similar to the material used in catheters and heart valves since the 1950s. It is also the same kind of material used in Norplant® capsules, another contraceptive implant system.
- The rods release levonorgestrel, a synthetic progestin that has been used in combined oral contraceptives and in progestin-only pills for more than 30 years.
- The delivery system can provide contraceptive protection for up to five years. The levonorgestrel diffuses out of the silicon rubber at a constant rate every day for five years.
- The Jadelle® system consists of two rods, unlike the Norplant® system that has 6 capsules. Because there are fewer implants, Jadelle® is easier to insert and remove than Norplant.
- Each Jadelle rod is 43mm long and 2.5mm in diameter.

### *Mechanism of Action*

- Pregnancy is prevented in Jadelle® users by a combination of mechanisms. The most important are
  - inhibition of ovulation
  - thickening of the cervical mucus, making it impermeable to sperm.
- Other mechanisms may add to these contraceptive effects.

### *Effectiveness*

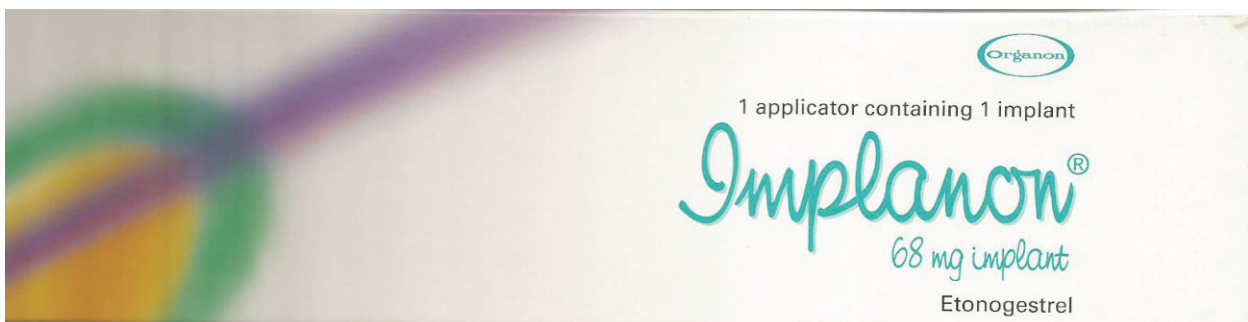
- Jadelle® is one of the most effective reversible contraceptives available.
- The cumulative pregnancy rate in clinical trials was 0.3% for three years and 1.1% percent for 5 years.
- Jadelle® has a lower failure rate than the pill and most IUDs.
- Its efficacy is comparable to that of surgical sterilization. The implant has also been approved for 5 years' use.

### **Product Profile of Implanon®**

Implanon<sup>R</sup> is:

- A reversible long-acting hormonal subdermal contraceptive that contains etonorgestrel.
- It is a single-rod system with a disposable applicator. A newer version of Implanon is also available. It is called Implanon NXT™ which can be seen on x-ray making it possible to check the location of the implant.
- Implanon NXT™ **also has a preloaded sterile applicator** which is for single use and disposable. Inserters familiar with the applicator for Implanon<sup>R</sup> need to familiarize themselves with the one for Implanon NXT™
- Each Implanon implant contains 68 mg of etonorgestrel.

**Figure 3.2.3: Implanon<sup>R</sup> (classic) Package**



**Figure 3.2.4: Implanon NXT™ Package**



### *Mechanism of Action*

- The contraceptive effect of Implanon® is primarily achieved by the inhibition of ovulation.
- Besides inhibition of ovulation, Implanon® also causes changes in the cervical mucus, which hinders the passage of spermatozoa.

### *Effectiveness*

- Less than 1 pregnancy per 100 women (1 per 1,000 women) for over three years use of Implanon.
- The contraceptive efficacy of Implanon® is comparable with that known for combined OCs.

## **B. Advantages and the Disadvantages of Contraceptive Implants**

### *Advantages of Implants*

- No repeated visits to the clinic are required
- Contraceptive implants are effective immediately if inserted within the first 7 days of menstrual cycle (5 days for Implanon)
- They are very effective in preventing pregnancy and safe for majority of women
- They are long-acting
- They may help prevent iron deficiency anemia, symptomatic pelvic inflammatory disease, and ectopic pregnancy
- Do not disturb breast milk production
- Less likely to cause headaches or raised blood pressures than estrogen-containing contraceptives
- No increased risk of cardio-vascular complications

### *Disadvantages of Contraceptive Implants*

- Contraceptive implants have common side effects:
  - may cause spotting and irregular vaginal bleeding for 60–70% of users;
  - amenorrhea (less common than irregular bleeding with all implants, but Implanon)

- headaches, abdominal pain, weight gain, breast tenderness, dizziness, nausea, mood change and acne
- some women may develop enlarged ovarian follicles
- Insertion and removal involve minor surgical procedures and therefore may be associated with bruising (discolouration of the arm), infection or bleeding
- The client cannot discontinue the method on her own
- Outline of the rods may be visible under the skin of some women, especially when the skin is stretched
- Contraceptive implants do not protect a woman from STIs/HIV

### C. Medical Eligibility Criteria for use of Implants

- ◆ The WHO MEC is:

A document that reviews the medical eligibility criteria for use of contraception, offering guidance on the safety of use of different methods for women and men with specific characteristics or known medical conditions.

- There are four categories.

Category	Description	When clinical judgment is available
1	No restriction to use	Use method under any circumstance
2	Benefits generally outweigh the risks	Generally use the method
3	Risks generally outweigh the benefits	Use of the method not usually recommended except if other methods are unavailable/unacceptable
4	Unacceptable health risks	Method not to be used

- *WHO Category 1:* Women who can use Contraceptive Implants without restriction
- *WHO Category 2:* Women who can generally use Contraceptive Implants; some follow up may be needed
- *WHO Category 3:* Use of Contraceptive Implants is not recommended in these women
- *WHO Category 4:* Women who should not use Contraceptive Implants
- ◆ The Trainer then requests the participants to read out (in turns) indications specified under each of the four categories.

#### **Women who can use implants *without restriction* (WHO Category 1)**

Women who:

- are of any age and parity, including nulliparous
- obese
- have uterine fibroids
- are breastfeeding within six weeks to six months postpartum

<sup>1</sup>Implants start to lose effectiveness sooner for heavier women (>70kg): these women may have to replace their implants earlier.



- have puerperal and post-abortion sepsis
- have pelvic inflammatory disease (previous and present)
- have increased risk of STIs or current STIs, including gonorrhoea or chlamydia
- have HIV infection or AIDS, but are not on ARV therapy
- are smoking at any age
- have hypertension below 160/100 mmHg
- have non-migrainous headaches
- have depressive disorders
- have endometrial or ovarian cancer
- have iron-deficiency anemia or sickle cell disease
- have acute or flare hepatitis, chronic hepatitis, or carrier
- have mild (compensated cirrhosis)
- take broad-spectrum antibiotics, antifungal or anti-parasitic medication

***Women who can generally use implants; some follow up may be needed (WHO Category 2)***

Women who have:

- drug interactions such as Rifampicin, Rifambutin, certain anti-convulsants, e.g. Phenytoin, ARVs
- cervical cancer (pre-treatment) or cervical intraepithelial neoplasia
- hypertension higher than 160/100 mm Hg
- history of DVT or current DVT while established on anticoagulant therapy
- major surgery with prolonged immobilization
- multiple risk factors for cardiovascular disease
- history or current ischaemic heart disease or stroke (for initiation only)
- migraine with aura at any age (for initiation only)
- diabetes with or without complications
- rheumatic disease, such as systemic lupus erythematosus if negative for antiphospholipid antibodies
- irregular or heavy vaginal bleeding patterns
- gall-bladder disease
- liver tumour, such as focal nodular hyperplasia

#### **D. Summary**

- Since contraceptive implants are progestin-only methods, they are suitable for a wide range of women.
- They make family planning possible throughout reproductive life.
- They may be used to postpone a first pregnancy or 'space' pregnancies.
- They may also be used to provide long-term contraception when the desired family size is reached.
- Since implants do not contain estrogen, they can be used in women who do not want to or cannot use combined oral contraceptives (COCs).
- The contraceptive actions of implants are reversible which is apparent from the rapid return of the normal menstrual cycle after removal of the implants.

## MODULE FOUR

### USING LEARNING GUIDES DURING MODEL AND CLINICAL PRACTICE

#### Learning Objectives

By the end of this session, participants should be able to:

- Discuss the terms associated with skill acquisition
- Explain the use of learning guides and checklist
- Discuss the advantages and disadvantages of competency-based skill assessment instruments
- Demonstrate the use of competency based assessment instrument
- Discuss the care of anatomic models

#### Session Overview

- Terms associated with skill acquisition
- Description of learning guides and checklist
- Advantages and disadvantages of competency-based skill assessment instruments
- Demonstration of the use of competency based Assessment Instrument
- Care of anatomic models

#### CONTENT

##### A. Terms associated with skill acquisition

- In the past, deciding whether a participant was competent (qualified) to perform a skill or activity during and, most important, after clinical training was often extremely difficult. This was due, in part, to the fact that competency was tied to the completion of a specified number of supervised procedures or activities.
- Unfortunately, unless participant performance is objectively measured relative to a predetermined standard, it is difficult to determine competency. Competency-based skill assessments (learning guides and checklists), which measure clinical skills or other observable behaviours relative to a predetermined standard, have made this task much easier.
- While learning guides are used to facilitate learning the steps or tasks (and sequence, if necessary) in performing a particular skill or activity, checklist are used to evaluate performance of the skill or activity objectively.
- Progress in the skill area is measured with reference to various levels or stages of performance. The three levels of performance in acquiring a new skill are:
  - *Skill Acquisition* –is defined as an act of getting something e.g. knowledge of a skill.

This represents the **initial phase** in learning a new clinical skill or activity. Assistance and coaching are necessary to achieve correct performance of the skill or activity.

- *Skill Competency* –Is defined as a skill that a person needs in a particular job or for a particular task.

This represents an **intermediate phase** in learning a new clinical skill or activity. The participant can perform the required steps in the proper sequence (if necessary) but may not progress from step to step efficiently.

- *Skill Proficiency* –Is defined as the ability to do something well because of training and practice.

This represents the **final phase** in learning a new clinical skill or activity. The participant efficiently and precisely performs the steps in the proper sequence (if necessary).

## **B. Use of Learning Guides and Checklist**

### ***Learning Guides***

- A learning guide contains the individual steps or tasks in sequence (if necessary) required to perform a skill or activity in a standardized way. Learning guides are designed to help the participant learn the correct steps and sequence in which they should be performed (**skill acquisition**), and measure progressive learning in small steps as the participant gains confidence and skill (**skill competency**).
- Learning guides can be used as a self or peer assessment tool. Examples of how learning guides can be used at different stages of the course are given below. They are not expected to perform all the steps or tasks correctly the first time they practice them. Instead the learning guides are intended to:
  - Assist the participant in learning the correct steps and sequence in which they should be performed (*skill acquisition*)
  - Measure progressive learning in small steps as the participant gains confidence and skill (*skill competency*).
  - Step by step process of using the learning guides:
    - Initially, participants can use the learning guides to follow the steps as the clinical trainer role-plays counselling a client or demonstrates a clinical procedure using anatomic models.
    - Subsequently, during the classroom sessions in which participants are paired, one “service provider” participant performs the procedure while the other participant uses the learning guide to prompt the “service provider” on each step.
    - During these sessions, the clinical trainer(s) can circulate from group to group to monitor how learning is progressing and check to see that the participants are following the steps outlined in the learning guide.
    - After participants become confident in performing the skill or activity (e.g. inserting an IUD in the pelvic model), they can use the learning guide to rate each other's performance. This exercise can serve as a point of discussion during a clinical conference before participants provide services to clients.

## **Checklist**

- The *Checklist* generally is derived from a learning guide. Unlike learning guides, which are by necessity quite detailed, competency-based checklists should contain only sufficient detail to permit the clinical trainer evaluate and record the overall performance of the skill or activity.
- If a checklist is too detailed, it can distract the clinical trainer from the primary purpose, which is to observe the overall performance of the participant objectively.

### *Important uses of Checklist:*

- Using checklists in competency-based clinical training:
  - Ensures that participants have mastered the clinical skills and activities, first with models and then with clients
  - Ensures that all participants will have their skills measured according to the same standard
  - Forms the basis for follow up observations and evaluations

## **C. Advantages and disadvantages of competency-based skill assessment instruments**

- The single greatest advantage of a competency-based assessment is that it can be used to facilitate learning a wide variety of skills or activities and measure participant behaviour in a **realistic job-related situation**.
  - Competency-based assessment instruments such as learning guides:
    - Focus on a skill that the participant typically would be expected to perform on the job, and
    - Break down the skill or activity into the essential steps required to complete the procedure.
    - Ensures that training is based on a standardized procedure
      - Standardizes training materials and audiovisual aids
      - Forms the basis of classroom or clinical demonstrations as well as participant practice sessions.

## **D. Disadvantages of competency-based skill assessment instruments:**

- It will take time and energy first to develop the instruments/tools and then to apply them to each participant.
- An assessment can be applied only by a clinical trainer who is proficient in the clinical procedure or activity being learned.
- An adequate number of skilled clinical trainers must be available to conduct the training because competency-based clinical training usually requires a one-on-one relationship.

## **E. Use of competency based Assessment Instrument**

The learning guides on a task performed on an anatomic model:

*Sample 4.1:* Learning Guide for IUD Insertion Techniques

*Sample 4.2:* Learning Guide for IUD Counselling Skills

*Sample 4.3:* Learning Guide for Implant (Jadelle<sup>R</sup>) Insertion Techniques

*Sample 4.4:* Learning Guide for Implant (Implanon<sup>R</sup>) Insertion Techniques

*Sample 4.5:* Learning Guide for Implant (Implanon<sup>TM</sup>) Insertion Techniques

*Sample 4.6:* Learning Guide for Implant Removal Skills (All Implants)

### **Summary**

- Providing participants with good counselling and clinical skills is one of the central purposes of most family planning training courses.
- Being able to measure learning progress satisfactorily and evaluate performance objectively are extremely important elements in the process of improving the quality of clinical training.
- The checklists can be used to measure a wide variety of participant skills and behaviours in realistic job-related situations.

# LISTS OF LEARNING GUIDES

- 4.1: Learning Guide for IUD Insertion and Removal Techniques
- 4.3: Learning Guide for Counselling Skills
- 4.4: Learning Guide for Implant (Jadelle<sup>R</sup>) Insertion Techniques
- 4.5: Learning Guide for Implant (Implanon NXT<sup>TM</sup>) Insertion Techniques
- 4.6: Learning Guide for Implant Removal Skills (All Implants)

## Sample 4.1: Learning Guide for IUD Insertion and Removal Techniques

### LEARNING GUIDE FOR IUD CLINICAL SKILLS

(To be used by Participants)

Rate the performance of each step or task observed using the following rating scale:

<p><b>Needs Improvement:</b> Step or task not performed correctly or out of sequence (if necessary) or is omitted</p> <p><b>Competently performed:</b> Step or task performed correctly in proper sequence (if necessary) but participant does not progress from step to step efficiently</p> <p><b>Proficiently performed:</b> Step or task efficiently and precisely performed in the proper sequence (if necessary)</p>
--

LEARNING GUIDE FOR IUD CLINICAL SKILLS						
STEP/TASK		CASES				
<b>CLIENT ASSESSMENT</b>						
1.	Greet client respectfully and with kindness					
2.	Determine that client has been counseled for insertion procedure					
3.	Take a reproductive health history. Ask for and record the following information to determine if the IUD is an appropriate choice for the client: Date of last menstrual period, menstrual interval (days) and bleeding pattern History of ectopic pregnancy Severe dysmenorrhea (painful periods) Severe anemia (Hb < 9g/dl or HCT < 27) Recent history of sexually transmitted genital tract infections (GTIs), PID (in last 3 months) or other STDs (HBV/HIV) Multiple sexual partners (either partner) Known or suspected cancer of genital tract					
<b>General Physical Examination</b>						
4.	Inform the client that you want to examine her generally					
5.	Check for pallor and jaundice					
6.	Examine the neck for any swelling					
7.	Examine the breasts for lumps, nipple discharge					
<b>Abdominal Examination</b>						
8.	Check that client has recently emptied her bladder and washed and rinsed her genital area if necessary					
9.	Tell client what is going to be done and encourage her to ask question					
10.	Help client onto examination table					

11.	Wash hands thoroughly with soap and water and dry with clean, dry cloth or air dry					
12.	Palpate abdomen and check for lower abdominal, especially suprapubic tenderness and masses or other abnormalities					
<b>Pelvic Examination</b>						
13.	Drape the woman appropriately for pelvic examination					
14.	Provide adequate light to see cervix					
15.	Open high -level disinfected instrument pan or sterile pack without touching instruments					
16.	Put new examination or high -level disinfected surgical gloves on both hands.					
17.	Arrange instruments and supplies on high -level disinfected or sterile tray.					
18.	Inspect external genitalia and urethral opening					
19.	Palpate Skene's and Bartholin's glands for tenderness or discharge					
20.	Swab the vulva					
21.	Perform bimanual exam: Determine if there is cervical motion tenderness Determine size, shape and position of uterus Rule out pregnancy or any uterine abnormality Check for enlargement or tenderness of adnexa					
22.	Perform rectovaginal exam only if: Position or size of uterus is questionable Possible mass behind the uterus					
23.	If performing rectovaginal exam, keep gloves on and go to steps 21a & 21b					
24.	If not performing r ectovaginal exam, immerse both gloved hands in 0.5% chlorine solution. Remove gloves by turning inside out If disposing of gloves, place in leak proof container/plastic bag					
25.	After completing rectovaginal exam, immerse both gloved hands in 0.5% chlorine solution, remove gloves by turning inside out and dispose of gloves in leak proof container or plastic bag.					
26.	Put on another pair of examination gloves					
27.	Insert vaginal speculum					
28.	Perform speculum exam: Check for vaginal lesions or discharge Inspect cervix Obtain vaginal and cervical and/or urethral specimens for microscopic examination if indicated (and testing is available)					
<b>Refer to higher level of care if infection is suspected</b>						
<b>INSERTION</b>						
<b>Pre-Insertion Tasks</b>						
1.	Tell client what is going to be done and encourage her to ask questions					
<b>Insertion Tasks</b>						
2.	Put new examination or high -level disinfected surgical gloves on both hands					
3.	Apply antiseptic solution two times to the cervix, especially the os, and vagina					
4.	Gently grasp cervix with tenaculum or Bonny Stopes forceps					
5.	While gently pulling on the tenaculum and without touching side walls of vagina or speculum blades, gently pass uterine sound through cervix to the fundus of the uterus					
6.	Confirm whether the position of the uterus is anterior or posterior. Remove uterine sound					
7.	Determine depth of uterine cavity					

8.	Load Copper T380A in sterile package: Partially open package and bend back white backing flaps Put white rod inside inserter tube Place package on flat surface Slide I.D card underneath arms of the IUD Hold tips of IUD arms and push on the inserter tube to start bending arms When arms touch sides of inserter tube, pull tube away from the folded arms of IUD Elevate inserter tube and push and rotate to catch tips of arms in tube. Push folded arms into inserter tube to keep them fixed in the tube					
9.	Set depth gauge to measure uterine depth with IUD still in sterile package, then completely open package					
10.	Check to be sure the folded arms and the depth gauge are lying flat against the card					
11.	Remove loaded inserter tube without touching anything that is not sterile; be careful not to push the white rod toward IUD					
12.	Hold blue depth gauge in horizontal position. While gently pulling on tenaculum, pass loaded inserter tube through the cervix until depth gauge touches cervix or resistance is felt.					
13.	Hold tenaculum and white rod stationary in one hand					
14.	Release arms of Copper T380A IUD using withdrawal technique (pull inserter tube toward you until it touches thumb grip of white rod).					
15.	Remove white rod and carefully push in on the inserter tube until slight resistance is felt (to ensure device is in place)					
16.	Partially withdraw the inserter tube and cut IUD strings to 3 - 4cm length					
17.	Remove inserter tube					
18.	If cutting is not performed, tuck the strings around the cervix in the fornices					
19.	Gently remove the tenaculum and place in 0.5% chlorine solution for 10minutes for decontamination					
20.	Examine cervix and if there is bleeding at the tenaculum puncture site(s), place cotton (or gauze) swab over bleeding and apply gentle pressure for 30-60 seconds.					
21.	Gently remove speculum and place in 0.5% chlorine solution for 10minutes for decontamination					
<b>POST INSERTION TASKS</b>						
22.	Before removing gloves, place all instruments in 0.5% chlorine solution for 10minutes for decontamination					
23.	Dispose of waste materials such as cotton balls or gauze by placing in a leak proof container or plastic bag.					
24.	Immerse both gloved hands in 0.5% chlorine solution. Remove gloves by turning inside out, place in leak proof container or plastic bag					
25.	Wash hands thoroughly with soap and water and dry with clean, dry cloth or air-dry					
26.	Check to be sure client is not having excessive cramping and answer any questions					
27.	Teach client how and when to check for strings – fortnightly and especially after menses					
28.	Discuss what to do if client experiences any side effects or problems					



29.	Provide follow-up visit instructions (the first follow -up visit is 1 month), and answer any questions					
30.	Remind the client that IUD does not protect against HIV/STIs					
31.	Assure client that she can have the IUD removed at any time					
32.	Observe client for at least 15 to 20 minutes before sending her home					
33.	Complete IUD card and record in client record					
<b>REMOVAL OF THE COPPER T380A IUD</b>						
1.	Greet client respectfully and with kindness					
2.	Check to be sure client has emptied her bladder and washed and rinsed her genital area if necessary					
3.	Tell the client what is going to be done and encourage her to ask questions					
4.	Help client onto examination table					
5.	Wash hands thoroughly with soap and water and dry with clean, dry cloth or air-dry					
6.	Put new examination or high -level disinfected surgical gloves on both hands					
7.	Perform bimanual exam: Determine if there is cervical motion tenderness Determine size, shape and position of uterus Palpate adnexa for abnormalities or enlargements					
8.	Insert vaginal speculum to see cervix and IUD strings					
9.	Apply antiseptic solution two times to the cervix, especially the os, and vagina					
10.	Grasp strings close to the cervix with heamostat or other narrow forceps, or long artery forceps, or sponge holding forceps.					
11.	Pull on strings slowly but firmly to remove IUD					
12.	Show IUD to client					
13.	Immerse IUD in 0.5% chlorine solution and dispose of in a leak proof container or plastic bag					
14.	Gently remove speculum and place in 0.5% chlorine solution for 10minutes for decontamination					
<b>POST REMOVAL TASKS</b>						
15.	Before removing gloves, place all instruments in 0.5% chlorine solution for 10 minutes for decontamination					
16.	Dispose of waste materials by placing in leak proof container or plastic bag					
17.	Immerse both gloved hands in 0.5% chlorine solution. Remove gloves by turning inside out, place in leak proof container or plastic bag					
18.	Wash hands thoroughly with soap and water and dry with clean, dry cloth or air dry					
19.	Record IUD removal in client record					

## Sample 4.2: Learning Guide for IUD Counselling Skills

### LEARNING GUIDE FOR IUD COUNSELLING SKILLS

(To be used by **Participants**)

Rate the performance of each step or task observed using the following rating scale:

**Needs Improvement:** Step or task not performed correctly or out of sequence (if necessary) or is omitted

**Competently performed:** Step or task performed correctly in proper sequence (if necessary) but participant does not progress from step to step efficiently

**Proficiently performed:** Step or task efficiently and precisely performed in the proper sequence (if necessary)

LEARNING GUIDE FOR IUD COUNSELLING SKILLS					
STEP/TASK		CASES			
<b>COUNSELLING (INSERTION)</b>					
<b>Initial Interview (Client Reception Area)</b>					
1.	Greet client respectfully and with kindness				
2.	Establish purpose of the visit and answer questions				
3.	Provide general information about family planning				
	Give the woman information about the contraceptive choices available and the benefits and limitations of each: Show where and how the method is used Explain how the method works and its effectiveness Explain possible side effects and other health problems Explain the most common side effects				
5.	Explain what to expect during the clinic visit				
<b>Method-Specific Counselling (Counselling Area)</b>					
6.	Assure of necessary privacy				
7.	Obtain biographic information (name, address, etc.)				
8.	Ask the client about her reproductive goals (Does she want to space or limit births?) and need for protection against GTIs and other STDs				
9.	Explore any attitudes or religious beliefs that either favor or rule out one or more methods				
10.	Discuss the client's needs, concerns and fears in a thorough and sympathetic manner				
11.	Help the client begin to choose an appropriate method				
<b>Client chooses an IUD</b>					
12.	Screen the client carefully to make sure there is no medical condition that would be a problem (compare client screening checklist)				
13.	Explain potential side effects and make sure that each is fully understood				
<b>Pre-Insertion Counselling (Examination/Procedure Area)</b>					
14.	Review Client Screening Checklist to determine if the IUD is an appropriate choice for the client and if she has any problems that should be monitored while the IUD is in place				
15.	Inform client about required physical and pelvic examination				
16.	Check that client is within 7 days of onset of menstrual period				
17.	Check for pregnancy if beyond day 7 (Non-medical counselors should refer client for further evaluation)				
18.	Describe the insertion procedure and what she should expect during the insertion and afterward				

<b>Post-insertion Counselling</b>						
19.	Teach client how and when to check for strings					
20.	Discuss what to do if the client experiences any side effects or problems					
21.	Provide follow up visit instructions					
22.	Remind client of 12-year effectiveness of the Copper T 380A IUD					
23.	Assure client she can return to the same clinic at any time to receive advice or medical attention and if desired, to have the IUD removed					
24.	Ask the client to repeat instructions					
25.	Answer client questions					
26.	Observe client for at least 15 to 20 minutes ask how she feels before sending her home.					

<b>COUNSELLING (REMOVAL)</b>						
<b>Pre-removal Counselling (Client Reception Areas)</b>						
	<b>STEP/TASK</b>	<b>CASES</b>				
		1	2	3	4	5
1.	Greet client respectfully and with kindness					
2.	Establish purpose of visit and answer any questions					
<b>Method-Specific Counselling (Counselling Areas)</b>						
3.	Ask client about her reason for removal and answer any questions					
4.	Ask client about her reproductive goals (Does she want to continue spacing or limiting birth?) and need for protection against GTIs and other STIs					
5.	Describe the removal procedure and what she should expect during the removal and afterward					
<b>Post-removal Counselling</b>						
6.	Discuss what to do if the client experiences any problems (e.g. prolonged bleeding or abdominal or pelvic pain)					
7.	Ask client to repeat instructions					
8.	Answer any questions					
9.	If client wants to continue spacing or limiting births using another method, review general and method-specific information about family planning methods					
10.	Help client obtain new contraceptive method or provide temporary (barrier) method until method of choice can be started.					
11.	Observe client for at least 15 to 20 minutes and ask how she feels before sending her home.					

### Sample 4.3: Learning Guide for Implant (Jadelle<sup>R</sup>) Insertion Techniques

#### LEARNING GUIDE FOR JADELLE<sup>R</sup> CLINICAL SKILLS

(To be used by **Participants**)

Rate the performance of each step or task observed using the following rating scale:

**Needs Improvement:** Step or task not performed correctly or out of sequence (if necessary) or is omitted

**Competently performed:** Step or task performed correctly in proper sequence (if necessary) but participant does not progress from step to step efficiently

**Proficiently performed:** Step or task efficiently and precisely performed in the proper sequence (if necessary)

Task/Activity		Number of Cases				
PRE-INSERTION COUNSELLING		1	2	3	4	5
1.	Greet woman respectfully and with kindness					
2.	Ask woman about her reproductive goals					
3.	If Jadelle <sup>R</sup> counselling has not been done, arrange for counselling prior to performing the procedure					
4.	Determine that the woman's contraceptive choice is Jadelle <sup>R</sup>					
5.	Review Client Screening Checklist to determine if the woman is an appropriate candidate for Jadelle <sup>R</sup>					
6.	Perform (or refer for) further evaluation, if indicated					
7.	Assess woman's knowledge about Jadelle <sup>R</sup> 's major side effects					
8.	Respond to client's needs and concerns about Jadelle <sup>R</sup>					
9.	Describe insertion process and what to expect					
<b>INSERTION OF JADELLE<sup>R</sup> CAPSULES</b>						
10	Ensure that client has thoroughly washed her arm with soap and water					
11	Select and position woman's arm correctly					
12	Determine the correct area on arm for insertion					
13	Determine that required sterile or high level disinfected (HLD) instruments and the 2 Jadelle <sup>R</sup> capsules are present					
<b>PRE-INSERTION TASKS</b>		<b>1</b>	<b>2</b>	<b>3</b>	<b>4</b>	<b>5</b>
14.	Wash hands with soap and water					
15.	Put on sterile or HLD gloves					
16.	Correctly, prepare insertion site with antiseptic solution					
17.	Place sterile or HLD drape over arm					
18.	Inject local anaesthesia just under skin; raises a small wheal					
19.	Advance needle to its hub and injects about 1 ml of local anaesthetic in each of 2 subdermal tracks (checks for anaesthetic effect)					
<b>INSERTING JADELLE<sup>R</sup> CAPSULES</b>						
20.	Insert trocar directly subdermally at an angle of 45 <sup>0</sup>					
21.	While tenting the skin, advance trocar and plunger to mark (1) near hub of trocar					

22.	Remove plunger and load the first capsule into trocar (with gloved hand or forceps)					
23.	Reinsert plunger and advance it until resistance is felt.					
24.	Hold plunger firmly in place with one hand and slide trocar out of incision until it reaches plunger handle					
25.	Withdraw trocar and plunger together until mark (2) near trocar tip just clears the insertion wound (do not remove trocar from skin)					
26.	With finger holding previously -placed capsule, guide insertion of trocar and plunger to mark (1)					
27.	Withdraw trocar only after insertion of second capsule					
28.	Palpate capsule to check that the two capsules have been inserted in a fan distribution (20° apart)					
29.	Palpate puncture site to check that two capsules are well clear of puncture site.					
<b>POST-INSERTION TASKS</b>		<b>1</b>	<b>2</b>	<b>3</b>	<b>4</b>	<b>5</b>
30.	Close the puncture wound with gauze, band aid or plaster after applying slight iodine solution to the gauze dressing					
31.	Apply pressure dressing snugly					
32.	Properly dispose of waste materials					
33.	Remove reusable gloves correctly and immerse them in chlorine solution					
34.	Wash hands with soap and water					
<b>POST-INSERTION COUNSELLING</b>						
35.	Draw the location of capsules in clients record and notes anything unusual					
36.	Instruct the client regarding wound care and return visit					
37.	Assure the client that she can have capsules removed at any time if she desired					

### Sample 4.4: Learning Guide for Implant (Implanon<sup>®</sup>) Insertion Techniques

#### LEARNING GUIDE FOR IMPLANT (IMPLANON<sup>®</sup>) INSERTION TECHNIQUES

Rate the performance of each step or task observed using the following rating scale:

**Needs Improvement:** Step or task not performed correctly or out of sequence (if necessary) or is omitted

**Competently performed:** Step or task performed correctly in proper sequence (if necessary) but participant does not progress from step to step efficiently

**Proficiently performed:** Step or task efficiently and precisely performed in the proper sequence (if necessary)

Task/Activity		Number of Cases				
<b>PRE-INSERTION COUNSELLING</b>		<b>1</b>	<b>2</b>	<b>3</b>	<b>4</b>	<b>5</b>
1.	Greet the client respectfully and with kindness					
2.	Ask the client about her reproductive goals					
3.	If Implanon <sup>®</sup> counselling not done, arranges for counselling prior to performing procedure					
4.	Determine that the client's contraceptive choice is Implanon <sup>®</sup>					
5.	Review the Client Screening Checklist to determine if she is an appropriate candidate for Implanon <sup>®</sup>					
6.	Perform (or refer for) further evaluation, if indicated					
7.	Assess the client's knowledge about Implanon <sup>®</sup> major side effects					
8.	Respond to the client's needs and concerns about Implanon <sup>®</sup>					
9.	Describe the insertion procedure and what to expect					
<b>GETTING READY</b>						
10.	Checks to be sure client has thoroughly washed her arm with soap and water					
11.	Selects and positions woman's arm correctly					
12.	Marks correct area on arm for insertion					
13.	Determines that required sterile or high level disinfected (HLD) instruments and Implanon <sup>®</sup> applicator					
<b>PRE-INSERTION TASKS</b>						
	<b>Tasks/Activity</b>	<b>1</b>	<b>2</b>	<b>3</b>	<b>4</b>	<b>5</b>
14.	Wash hands with soap and water					
15.	Put on sterile or HLD gloves					
16.	Correctly clean the removal site with antiseptic solution					
17.	Place sterile or HLD drape over arm					
18.	Inject local anaesthesia just under skin; raises a small wheal					
19.	Advance needle to its hub injects about 2 ml of local anaesthetic along insertion or removal					

<b>INSERTING IMPLANON CAPSULES</b>					
20.	Stretch skin at insertion site with thumb and index finger and insert tip of needle angled at 20°				
21.	Advance needle to its full length while lifting the skin				
22.	Break the seal of applicator and turn the obturator to 90°				
23.	Fix the obturator with one hand against the arm and retract the cannula out of arm				
24.	Check the needle for absence of the Implant				
25.	Palpate to verify presence of implant				
<b>POST-INSERTION TASKS</b>					
26.	Apply sterile gauze with a pressure bandage				
27.	Fill out user card and hands it to client				
28.	Draw position of implant in client record				
29.	Drop applicator in sharps disposal container				
<b>POST-INSERTION COUNSELLING</b>					
30.	Instruct client regarding wound care and return visit				
31.	Assure client that she can have the capsule removed at any time if she desires				
32.	Observe client for at least 5 minutes before sending home				

## Sample 4.5: Learning Guide for Implant (IMPLANONNXT™) Insertion Techniques

### LEARNING GUIDE FOR IMPLANT (IMPLANONNXT™) INSERTION TECHNIQUES

Rate the performance of each step or task observed using the following rating scale:

**Needs Improvement:** Step or task not performed correctly or out of sequence (if necessary) or is omitted

**Competently performed:** Step or task performed correctly in proper sequence (if necessary) but participant does not progress from step to step efficiently

**Proficiently performed:** Step or task efficiently and precisely performed in the proper sequence (if necessary)

Task/Activity		Number of Cases				
<b>PRE-INSERTION COUNSELLING</b>		<b>1</b>	<b>2</b>	<b>3</b>	<b>4</b>	<b>5</b>
1.	Greet the client respectfully and with kindness					
2.	Ask the client about her reproductive goals					
3.	If Implanon NXT™ counselling not done, arranges for counselling prior to performing procedure					
4.	Determine that the client's contraceptive choice is Implanon NXT™					
5.	Review the Client Screening Checklist to determine if she is an appropriate candidate for Implanon NXT™					
6.	Perform (or refer for) further evaluation, if indicated					
7.	Assess the client's knowledge about Implanon NXT™ major side effects					
8.	Respond to the client's needs and concerns about Implanon NXT™					
9.	Describe the insertion procedure and what to expect					
<b>GETTING READY</b>						
10.	Check to be sure client has thoroughly washed her arm with soap and water					
11.	Select and position woman's arm correctly					
12.	Mark correct area on arm for insertion					
13.	Determine that required sterile or high level disinfected (HLD) instruments and Implanon NXT™ applicator					
<b>PRE-INSERTION TASKS</b>						
	<b>Tasks/Activity</b>	<b>1</b>	<b>2</b>	<b>3</b>	<b>4</b>	<b>5</b>
5.	Wash hands with soap and water					
6.	Put on sterile gloves					
7.	Correctly, clean the removal site with antiseptic solution					
8.	Place sterile drape over arm					
9.	Inject local anaesthesia just under skin; raises a small wheal					
10.	Advance needle to its hub injects about 2 ml of local anaesthetic along insertion or removal					



<b>INSERTING IMPLANON NXT™ CAPSULE</b>						
11	Remove the sterile preloaded disposable applicator for IMPLANON NXT™ carrying the implant from its blister.					
12	Hold the applicator just above the needle at the textured surface area and remove the transparent protection cap from the needle which contains the implant.					
13	If the cap does not come off easily, the applicator should not be used. You may see the white-colored implant by looking into the tip of the needle					
14.	With your free hand, stretch the skin around the insertion site with thumb and index finger. Puncture the skin with the tip of the needle angled about 30°.					
15	Lower the applicator to a horizontal position. While lifting the skin with the tip of the needle, slide the needle to its full length. You may feel slight resistance but do not exert excessive force.					
16	While keeping the applicator in the same position and the needle inserted to its full length, unlock the purple slider by pushing it slightly down. Move the slider fully back until it stops, leaving the implant now in its final subdermal position and locking the needle inside the body of the applicator.					
17	Verify the presence of the implant in the woman's arm immediately after insertion by palpation. By palpating both ends of the implant, you should be able to confirm the presence of the 4 cm rod					
18	Apply a small adhesive bandage over the insertion site.					
19.	Request that the woman palpate the implant.					
20.	Palpate to verify presence of implant					
<b>POST-INSERTION TASKS</b>						
21	Apply sterile gauze with a pressure bandage					
22	Fill out user card and hands it to client					
23	Draw position of implant in client record					
24	Drop applicator in sharps disposal container					
<b>POST-INSERTION COUNSELLING</b>						
25.	Instruct client regarding wound care and return visit					
26.	Assure client that she can have the capsule removed at any time if she desires					
27.	Observe client for at least 5 minutes before sending home					

## Sample 4.6: Learning Guide for Implant Removal Skills

### LEARNING GUIDE FOR IMPLANT REMOVAL TECHNIQUES (ALL IMPLANTS)

Rate the performance of each step or task observed using the following rating scale:

**Needs Improvement:** Step or task not performed correctly or out of sequence (if necessary) or is omitted

**Competently performed:** Step or task performed correctly in proper sequence (if necessary) but participant does not progress from step to step efficiently

**Proficiently performed:** Step or task efficiently and precisely performed in the proper sequence (if necessary)

Task/Activity		Number of Cases				
<b>PRE-REMOVAL COUNSELLING</b>		<b>1</b>	<b>2</b>	<b>3</b>	<b>4</b>	<b>5</b>
1.	Greet woman respectfully and with kindness					
2.	Ask client her reasons for removal and answers any questions					
3.	Review client's present reproductive goals					
4.	Describe the removal procedure and what to expect					
<b>REMOVAL OF IMPLANT CAPSULES</b>						
<b>GETTING READY</b>						
1.	Check to be sure client has thoroughly washed her arm with soap and water					
2.	Position the client's arm correctly and palpate the capsules to determine point for removal incision					
3.	Determine that the required sterile or HLD instruments and supplies are present					
<b>PRE-REMOVAL TASKS</b>						
4.	Wash hands with soap and water					
5.	Put on sterile or HLD gloves					
6.	Correctly clean removal site with antiseptic solution					
7.	Place sterile or HLD drape over arm					
8.	Inject small amount of anaesthetic at the incision site and under the end of the capsules (checks for anaesthetic effect)					
<b>REMOVAL IMPLANT CAPSULES (STANDARD METHOD)</b>						
	<b>Tasks/Activity</b>	<b>1</b>	<b>2</b>	<b>3</b>	<b>4</b>	<b>5</b>
9.	Make a small (3-4 mm) incision with scalpel at tip of capsules					
10.	Locate easiest capsules to remove and gently push it towards the incision until the tip is visible					
11.	Grasp end of capsule with small forceps					
12.	If necessary, open fibrous sheath with scalpel and remove capsules					
13.	Inject more anaesthetic if required					
<b>DIFFICULT REMOVALS</b>						
14.	If capsules are not close to incision, grasp distant capsule with tips of curved forceps and properly rotate (flips and/or twists) forceps to expose capsules					
15.	Clean fibrous sheaths from implant with scalpel blade, gauze or forceps tip					
16.	Grasp exposed capsule with second forceps and removes it					

REMOVING CAPSULES (POP-OUT METHOD)						
	Tasks/Activity	1	2	3	4	5
17.	Push on proximal end of capsules (nearest the shoulder) to cause distal tip (nearest the elbow) to protrude (push up skin)					
18.	Open fibrous sheaths over tip with scalpel if needed					
19.	Gently squeeze tip into the incision and "pops out" capsule through the incision.					
20.	After removal of all the capsules, count again to be sure all capsules have been removed and show them to the client					

REMOVING CAPSULES ("U" TECHNIQUE METHOD)		CASES				
	Tasks/Activity	1	2	3	4	5
21.	Make a vertical 4 mm incision about 5 mm from the distal end of the rods between the two implants (or one in case of Implanon <sup>R</sup> and Implanon NXT <sup>TM</sup> )					
22.	Insert the implant holding forceps through the incision					
23.	Stabilize the closest rod with index finger					
24.	Grasp the rod and pull towards incision					
25.	Clean off fibrous sheath with gauze or scalpel					
26.	Remove the rod with Crile/Mosquito forceps					

POST-REMOVALS TASKS						
	Tasks/Activity	1	2	3	4	5
27.	Bring the edges of incision together and place a gauze slightly soaked with iodine on top of it					
28.	Close it with a butterfly bandage, band aid or surgical tape					
29.	Place all instruments in chlorine solution for decontamination					
30.	Properly dispose of waste materials					
31.	Wash hands with soap and water					

POST-REMOVALS COUNSELLING						
	Tasks/Activity	1	2	3	4	5
32.	Instruct the client regarding wound care and return visit					
33.	Discuss what to do if any problems					
34.	Counsel the client regarding new contraceptive method if desired					
35.	Assist the client in obtaining new contraceptive method or provide temporary (barrier) method until method of choice can be started					
36.	Observe client for at least five minutes before sending home					

## Module Five - Session 1: IUD Insertion Techniques

### Learning Objectives

By the end of this session, participants should be able to:

- Identify the equipment and materials for IUD insertion procedures
- List timing of insertion with regard to menstruation, postpartum, post abortion and lactation periods
- Demonstrate the correct steps in the IUD insertion procedure and explain the rationale for each step.
- Demonstrate loading of the CuT 380A IUD in the package.
- Explain the instructions to be given to clients after insertion.
- Schedule follow-up appointments with the clients after the procedure.

### Session Overview

- Equipment and materials for CuT 380A IUD insertion procedures
- Timing of insertion with regard to menstruation, postpartum, post abortion and lactation periods
- Demonstration of loading of the CuT 380A IUD in the package.
- Demonstration of the correct steps in the CuT 380A IUD insertion procedure and the reasons for each step.
- Instructions to be given to clients after insertion.
- Scheduling follow-up appointments with the clients after the procedure.

## CONTENT

### A. Introduction

#### Timing of insertion with regard to menstruation, postpartum, post-abortion and lactation periods

- Many of the problems associated with CuT 380A IUDs (expulsion, infection and perforation) are due to improper or careless insertion.
- To minimize post-insertion problems, all phases of the insertion process must be performed carefully and gently.

#### *Interval and postpartum:*

IUD can be inserted

- anytime during the menstrual cycle, provided pregnancy has been ruled out.
- if woman is within the first 12 days of her menstrual cycle, no need for a pregnancy test or other means to rule out pregnancy
- if it is more than 12 days after the start of monthly bleeding, provider should rule-out pregnancy by other means (pregnancy checklist, pregnancy test, etc.)
- no back-up method is needed after IUD insertion regardless of timing
- immediately or within the first 12 days after abortion if there is no infection
- four to six weeks after a vaginal delivery or Caesarean section (if not inserted within the first 48 hours postpartum)

**Postpartum IUD (PPIUD) can be inserted only by trained personnel (nurse midwife/physician):**

- within 10 minutes post-delivery of placenta — **post-placental**
- after 10 minutes but within 48 hours of delivery — **pre-discharge**
- during caesarean section — **trans-Caesarean**

## **B. Equipment and materials for IUD insertion procedures**

*Equipment and materials for IUD insertion*

- Examination couch/insertion couch
- Light source (torch or angle-poised lamp)
- A trolley containing the following:
  - Speculum (various sizes)
  - Tenaculum (**please do not use vulsellum – it is too traumatic**)
  - Sponge holding forceps
  - Uterine sound (plastic preferably)
  - A pair of scissors
  - Sterile gloves
  - Straight artery forceps
  - Gallipots (2)
  - IUDs
  - Inserters and introducers (where applicable)
  - Antiseptic lotion (e.g. *Savlon, Hibitane, Purit, Bethadine*)
  - Sterile receiver with cover containing 1 in 2500 iodine solution or 75% alcohol
  - Bowl with lid, swabs, pads, sterile towel
  - Sodium hypochlorite bleach (e.g. *Jik, Parozone*) 0.5% Solution

If the instruments come in a sterile or high level disinfection (HLD) pack, do not open the pack before the screening pelvic examination has been completed and a final decision to insert the IUD has been made.

## **C. Correct steps in the IUD insertion procedure and rationale for each step including loading of the IUD in the package.**

### **Procedure**

#### **Client preparation**

- Screen client for eligibility using the **screening checklist for initiation of IUD**.
- Explain the procedure of IUD insertion to the client to ensure her cooperation and relaxation
- Demonstrate the procedure with a hand held uterine or pelvic model (where available)
- Ensure that she has emptied her bladder

#### **Steps**

- Do a general physical examination of the:
  - breasts for abnormal masses and discharge
  - abdomen for masses and tenderness
- Perform a pelvic examination wearing sterile gloves
  - external genitalia — lesions, abnormal discharge
  - **bi-manual examination**
  - note shape, size, position, tenderness, and mobility of the uterus
  - feel for the adnexa — whether ovaries are enlarged or fallopian tubes thickened and tender

- Perform speculum examination to exclude abnormal vaginal discharge, cervicitis. If infection is found/suspected, postpone insertion
- Take a pap smear (if none has been done in the past two years)

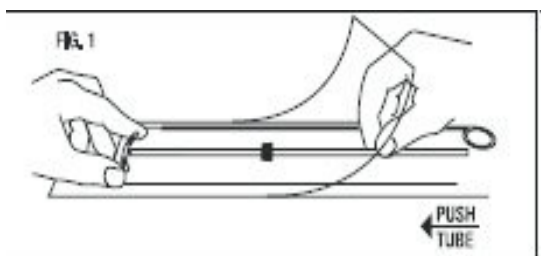
***If all the above are normal***

- Leave clean Cusco's/Graves speculum in the vagina
- Clean the vagina and cervix with antiseptic solution (*Savlon* or mixture of Chlorhexidine and *Savlon*)
- Grasp anterior lip of the cervix with a tenaculum (at 10 o'clock and 2 o'clock positions to minimize bleeding)
- Gently place traction on the cervix with the tenaculum to reduce the angle between the uterine body and the cervix
- While maintaining traction on the tenaculum, gently pass a uterine sound into the uterine cavity until contact is made with the fundus
- Measure the depth from the external os to the top of the fundus by withdrawing the sound and looking at the level of blood or mucus on the sound or by marking the level of the external os on the uterine sound with your index finger before withdrawing the sound.
- If the uterus is less than 6cm or greater than 9cm, discontinue procedure.
- Load the device into the inserter

***Loading the IUD in the package:***

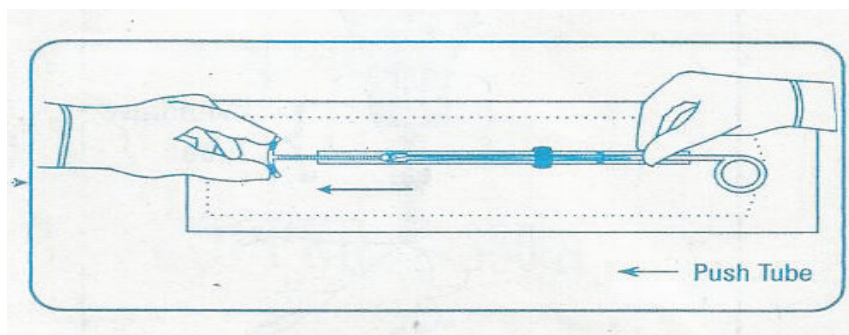
- ◆ The Trainer displays the slide containing Figure 5.1.1– “Loading the IUD in the package” and demonstrates the activity as s/he displays the slides containing Figures 5.1.2 (Bending the T-arms and pushing into the tube), Figure 5.1.2 (Pushing the T-arms into the Tube), and Figure 5.1.3 (IUD loaded in the package; ready for insertion).

**Figure 5.1.1: Loading the IUD in the Package**



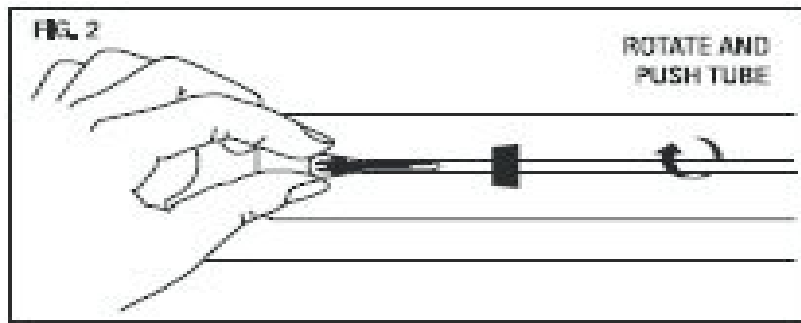
Bring the thumb and index finger closer together to continue bending the arms until they are alongside the stem. Use the other hand to withdraw the insertion tube just enough so that the insertion tube can be pushed and rotated onto the tips of the arms. Your goal is to secure the tips of the arms inside the tube (Fig. 5.1.3).

**Figure 5.1.2: Loading the IUD in the Package; Bend the T arms and push into the tube**



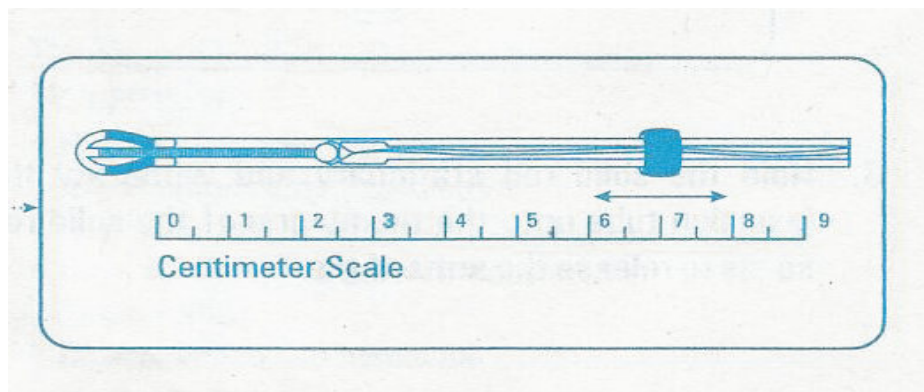
**Note:** Insert the arms no further than necessary to insure retention

**Figure 5.1.3: Loading the IUD in the Package, Push the T arms into the Tube**



Introduce the solid white rod into the insertion tube from the bottom, alongside the threads, until it touches the bottom of the Cu T 380A.

**Figure: 5.1.4: IUD loaded in the Package; ready for Insertion**



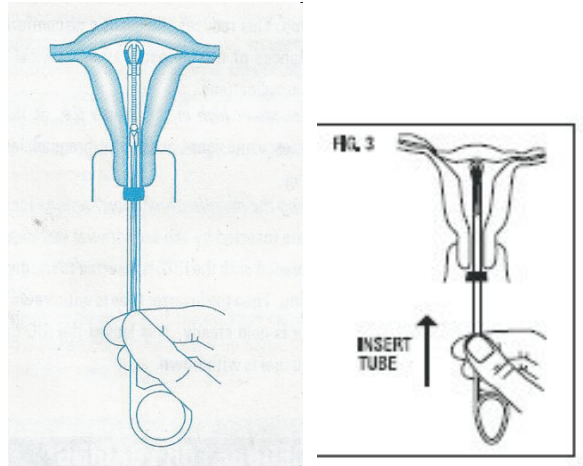
- ◆ Steps for intra-uterine placement of the pre-loaded CuT 380A are as displayed in the slides containing Figures 5.1.4 (Introducing loaded IUD into the uterus), Figure 5.1.5 (Withdrawing the tube to release the T-arms), Figure 5.1.6 (Pushing the tube up without moving the rod), 5.1.6 (Holding the tube steady while withdrawing the white rod) and Figure 5.1.7 (IUD correctly placed in the uterine cavity).

### **STEPS FOR INTRAUTERINE PLACEMENT OF THE PRE-LOADED Cu T 380A**

**Note:** To introduce the loaded inserter using the withdrawal method, observe the no-touch technique in all steps, (i.e. loading the **IUD** in the inserter inside the sterile package):

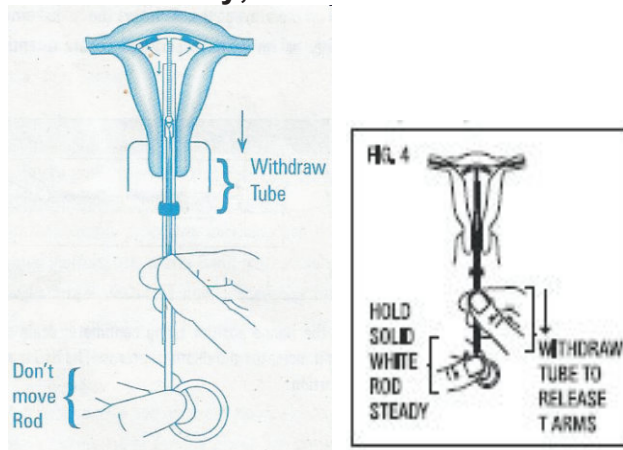
- Clean the cervix with antiseptic
- be careful not to touch the vaginal wall or speculum with the uterine sound or loaded IUD/inserter
- pass the uterine sound or loaded **IUD** inserter, **only once**, through the cervical canal
- Grasp the insertion tube at the open end of the package; adjust the blue flange so that the distance from the top of the Cu T 380A (where it protrudes from the inserter) to the blue flange is the same as the uterine depth that you measured with the sound.
- Rotate the insertion tube so that the horizontal arms of the T and the long axis of the blue flange lie in the same horizontal plane (Fig. 5.1.5).
- Now pass the loaded insertion tube through the cervical canal until the Cu T 380A just touches the fundus of the uterus. The blue flange should be at the cervix in the horizontal plane.

**Figure 5.1.5: IUD Insertion: Introduce loaded IUD into the uterus**



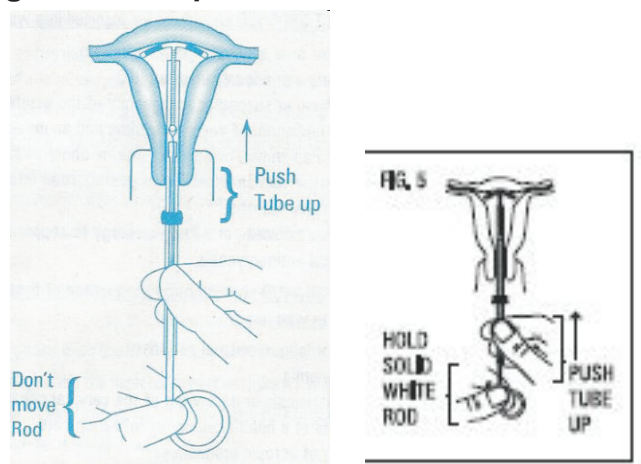
- To release the arms of Cu T 380A, hold the solid white rod steady and withdraw the insertion tube no more than one centimeter. This releases the arms of Cu T 380A high in the uterine fundus (Fig. 5.1.6).

**Figure 2: Keep the rod steady; withdraw the Tube to release the T-arms**



- Gently and carefully move the insertion tube upward toward the top of the uterus, until slight resistance is felt. This will ensure placement of the T at the highest possible position within the uterus (Fig. 5.1.7).

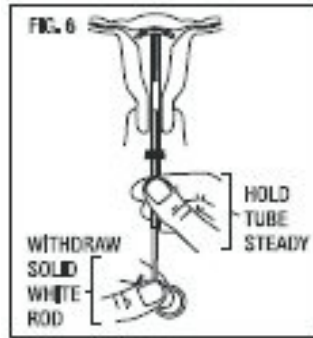
**Figure 3: Pushing the Tube up: Don't Move Rod**



- Hold the insertion tube steady and withdraw the solid white rod (Fig. 5.1.8).



**Figure 4: Hold the tube steady; withdraw the white rod**

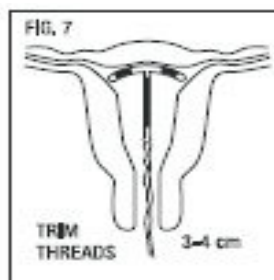


- Gently and slowly withdraw the insertion tube from the cervical canal. Only the threads should be visible protruding from the cervix. (Fig. 5.1.9).
- Wrap the threads around the client's cervix. DO NOT TRIM THE THREAD.

**Note:** If you suspect that the CuT 380A is not in the correct position, check placement (with ultrasound, if necessary). If the CuT 380A is not positioned completely within the uterus, remove it and replace it with a new Cu T 380A.

Do not reinsert an expelled or partially expelled CuT 380A IUD.

**Figure 5: IUD correctly placed in the uterine cavity.**



#### **D. Instructions to be given the clients after insertion**

##### *Post-Insertion Procedure for CuT 380A:*

- Ask the client about pain, fainting attacks, or any other discomfort
- Allow the client to rest on the couch for five minutes and then help her down
- Record
- There may be increased bleeding and/or cramping for a few days and that these are normal.
- Heavier menstrual bleeding, and possible bleeding between periods, is common for the first 3–6 months after insertion;
- Inspect all sanitary pads or panties during menses because expulsion is more common during menstruation.
- Check for string after each menstrual period (recommended, but not required if woman is uncomfortable inserting fingers into vagina);
- If at risk of STIs (e.g. multiple sexual partners, or partner with multiple partners), use condoms in addition to IUD for dual protection
- Tell the client that she may have sexual intercourse as soon as it is comfortable for her;
- Report to the nearest family planning clinic if you notice any of the following:

- **P** - period late or abnormal bleeding
- **A** - abnormal pain or pain with intercourse
- **I** - infection exposure, such as gonorrhoea, abnormal discharges
- **N** - not feeling well, fever or chills
- **S** - strings missing, shorter or longer
- Inform your physician of the presence of an IUD if you are going for any gynaecological surgical procedure
- Maintain good personal hygiene

#### **E. Schedule follow-up appointments with the clients after the procedure**

##### *First visit (4–6 weeks after insertion)*

- Ask the client about her health generally
- Ask about any complaints
- Ask about variations in her menstrual cycle, including inter-menstrual bleeding or spotting, excessive blood loss, and painful menstruation
- Ask her when she last felt the strings of the device (if she checks the strings)
- Carry out abdominal and pelvic examination
- Inspect the cervix to confirm the presence of strings, if long, trim
- Note any cervical discharge
- Palpate for pelvic tenderness
- Advise client on personal hygiene

##### *Schedule of subsequent follow-ups (if all is well):*

- Yearly visits until the client wishes to have the device removed or the life span of the device expires - Copper T-380A— 12 years;
- Repeat the activities of first visit at each subsequent visit;
- Encourage a pap smear every two years

#### **F. Summary/Evaluation**

- Long-term success, as defined by satisfied clients and high continuation rates, will occur only if CuT 380A IUD insertion is properly conducted and the provider recognizes the importance of providing follow-up care (including counselling) and prompt management of side effects as well as other problems should they occur.

## Module Five- Session 2: Jadelle<sup>®</sup> Implant Insertion Techniques

Time: 1 hour

### Learning Objectives

By the end of this session, participants should be able to:

- State the timing of insertion with regard to menstruation, postpartum, post abortion and lactation periods.
- Identify the equipment and materials for Jadelle<sup>®</sup> Implants insertion procedures.
- Demonstrate the correct insertion technique with regard to asepsis, anaesthesia, location of incision, and careful correct placement of the implants.
- Demonstrate the unique insertion techniques of Jadelle<sup>®</sup> implants.
- Demonstrate the correct application of dressing after insertion.
- Explain the instructions to be given to clients after insertion.
- Schedule follow-up appointments with the clients after the procedure.

### Session Overview

- Equipment and materials for Jadelle<sup>®</sup> implants' insertion procedures.
- Timing of insertion with regard to menstruation, postpartum, post abortion and lactation periods.
- Demonstration of the correct insertion technique for Jadelle<sup>®</sup> implants with regard to asepsis, anaesthesia, location of incision, and careful correct placement of the implants.
- Demonstration of the correct application of dressing after insertion.
- Instructions to be given to clients after insertion.
- Scheduling follow-up appointments with the clients after the procedure.

## CONTENT

### A. Introduction

Timing of insertion with regard to menstruation, postpartum, post-abortion and lactation periods

- Insertion techniques involve correct subdermal placement of the implants.
- The insertion procedure for Implanon being slightly different from those of Jadelle, is described separately.

#### *Timing of Insertion*

##### *Having menstrual cycles*

- Any time it is reasonably certain that she is not pregnant; *If she is not at risk of pregnancy (for example, has not had sex since last menstrual period), she may start using Implant at any time she wants;*
- If starting during the first 7 days after menstrual bleeding starts, and if she is still bleeding, no back-up method is needed for extra protection;
- If she is not bleeding or she is starting on or after day 8 of her menstrual period, she should use condoms or avoid sex for 48 hours after insertion. If possible, give her condoms.

### *After Childbirth*

- Irrespective of breastfeeding status, Implants can be inserted less than 48 hours after childbirth.
- Any time it is reasonably certain, that she is not pregnant. If not reasonably certain, she should avoid sex or use condoms until her first period begins and then start Jadelle<sup>R</sup> Implants.

### *After Miscarriage or Abortion*

- Immediately or in the first 7 days after either first or second – trimester miscarriage or abortion
- Later, any time it is reasonably certain that she is not pregnant

### *When stopping another method*

- Immediately

## B. Equipment and materials for Jadelle<sup>R</sup> Implants insertion procedures

### *Equipment and materials for Implant insertion procedures*

- One set of implant capsules
- Trocar and cannula as supplied
- Sterilized surgical drapes
- Sterile gloves preferably devoid of talcum powder
- Antiseptic solution like *Savlon*, *Hibitane* or *Betadine*
- Local anesthetic agent like *Xylocaine without Adrenaline 1%*
- Syringe and needle
- Sterile gauze/cotton wool
- Plaster
- Artery forceps (2)
- Scalpel and blade (size 12) (optional)
- Examination couch with arm rest
- Disinfectant solution, e.g. *Jik*, *Bethadine*
- Plastic bowl

## B, Correct insertion technique with regard to asepsis, anaesthesia, location of incision, and careful correct placement of the implants

### *Client Preparation*

#### ◆ The following steps should be noted in *Client preparation*

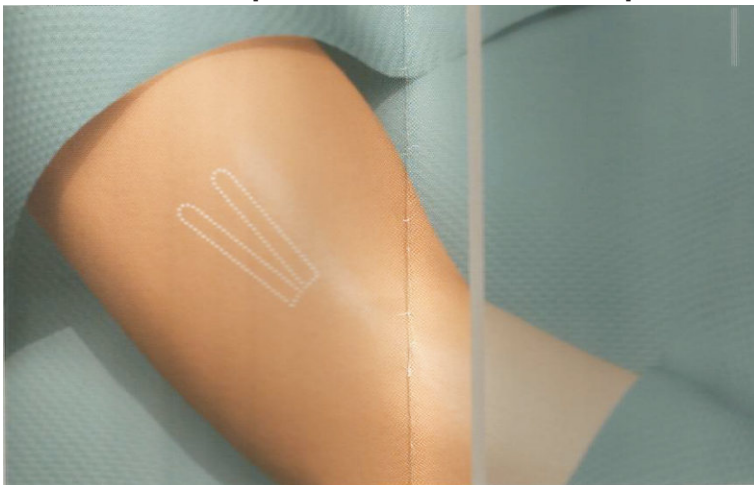
- Give clear information about probable changes in bleeding pattern during the menstrual cycle and other possible side effects;
- Describe the insertion and removal procedures and what the client should expect during and afterwards;
- Ensure client's cooperation and relaxation;
- Review client assessment data to determine if the client is an appropriate candidate for implants or if she has any problems that should be monitored more frequently while the implants are in place;
- Do a general examination;

- Do a pelvic examination *if needed or requested by client* (pelvic examinations are not necessary for safe implant initiation and use, but may be indicated for other reasons and are part of the preventive medicine practices and health promotion);
  - Instruct the client to lie on the couch with arm stretched out comfortably
  - Support arm with arm rest
  - Use proper infection prevention procedure
  - Wash hands
  - Ask the patient to lie down on the examination table with her non-dominant arm extended on a sterile cloth on the other table, at right angles to her body.
  - Clean the area of insertion with antiseptic solution: iodine (if available) and finally with spirit
  - Apply sterile drapes exposing the insertion area only (under the skin of the upper arm).
- B. Correct insertion technique with regard to asepsis, anaesthesia, location of incision, and careful correct placement of the implants

#### Steps for inserting contraceptive implant

- Instruct the client to lie on the couch with arm stretched out comfortably
- Support arm with arm rest
- Use proper infection prevention procedure
- Wash hands with soap and running water.
- Ask the patient to lie down on the examination table with her non-dominant arm extended on a sterile cloth on the other table, at right angles to her body. The implants will be inserted subdermally in the shape of a narrow V, opening towards the armpit.
- Clean the area of insertion with antiseptic solution: iodine (if available) and finally with spirit
- Apply sterile drapes exposing the insertion area only (under the skin of the upper arm).

**Figure 5.2.1: Subdermal placement of Jadelle<sup>®</sup> implants**

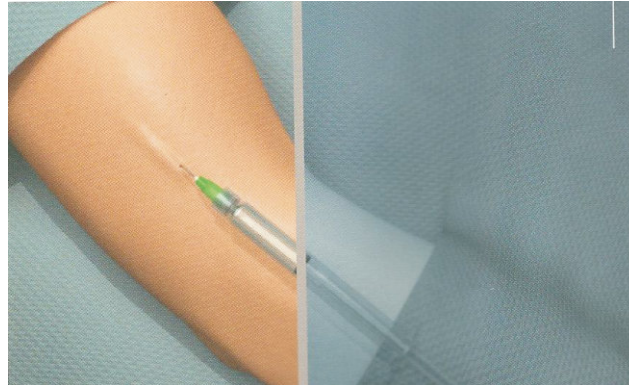


- Clean the client's upper arm with an antiseptic solution, and cover the arm with either two sterile clothes or a dry sterile fenestrated drape. The optimal insertion area is in the medial aspect of the upper arm about 6 – 8 cm above the fold of the elbow.
- Open the **Jadelle<sup>®</sup>** pouch by pulling apart the films of the pouch and let the two implants drop on a sterile cloth. Do not touch the inside of the package or its contents with bare hands. There should be two implants.

**Note:** Always use sterile gloves or forceps when handling the rods. If an implant is contaminated, e.g., falls on the floor. Leave it for later disposal. Open a new package and continue with the procedure.

- First determine the absence of known allergies to the anaesthetic agent or related drugs. Fill the syringe with 2 – 4 mls of local anaesthetic.
- Anaesthetize the insertion area by inserting the needle just under the skin about 4 to 5.5 cm in the direction where you are planning to introduce the trocar.
- Insert the trocar directly through the skin without making an incision with a scalpel.

**Figure 5.2.2: Anaesthetizing the insertion area**



- The trocar has two marks. The mark close to the handle indicates how far the trocar should be introduced under the skin before loading the implant. The mark closest to the tip indicates how much of the trocar should be left under the skin following the insertion of the first implant. When inserting the trocar, avoid touching the part of the trocar that will go under the skin.

**Figure 5.2.3: Marks on the Trocar**

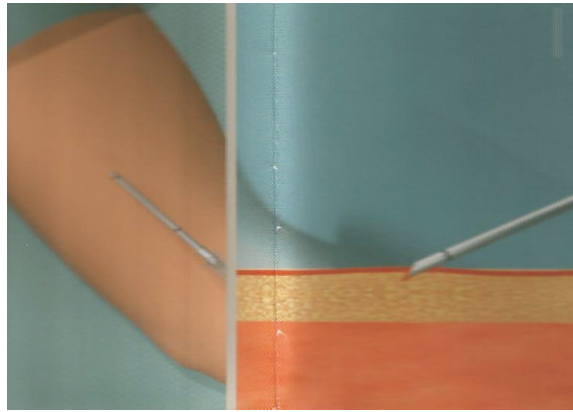


- Once the tip of the trocar is beneath the skin, it should be directed along the skin horizontally by pointing slightly upwards toward the raising the skin (tenting) to keep the implant in the subdermal plane. Throughout the insertion procedure, the trocar should be oriented with the bevel up.

**Note:** It is important to keep the trocar subdermal by tenting the skin with the trocar, as failure to do so may result in deep placement of the implants causing a more difficult removal.

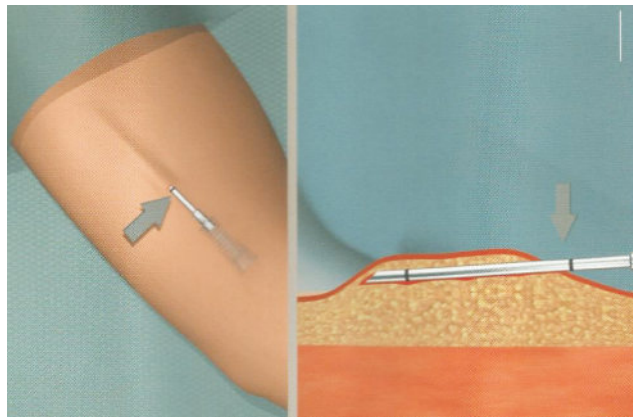
Do not force the trocar, and if you feel any resistance, try another direction.

**Figure 5.2.4: Introducing the trocar just beneath the skin**



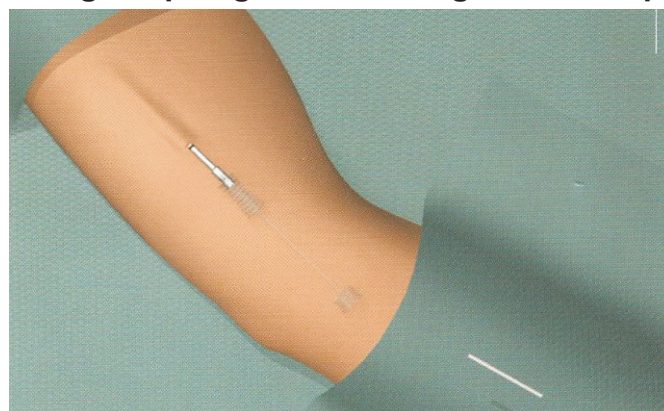
- Advance the trocar beneath the skin about 5.5 cm from the incision to the mark closest to the handle of the trocar

**Figure 5.2.5: Advancing to the mark while tenting**



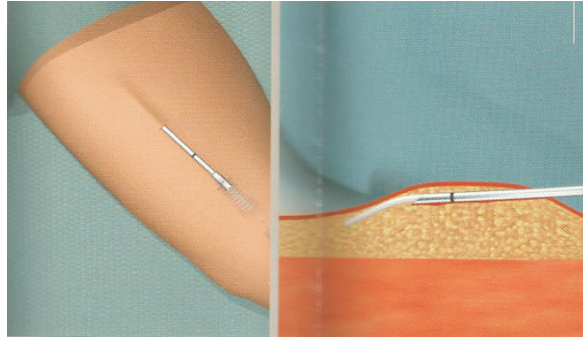
- Remove the plunger when the trocar is advanced to the correct mark (Figure 5.2.6).
- Load the first implant into the trocar either with tweezers or fingers.
- Push the implant gently with the plunger to the tip of the trocar until resistance is felt. Never force the plunger.

**Figure 5.2.6: Removing the plunger and loading the first implant**



- Hold the plunger steady and pull the trocar back along it until it touches the handle of the plunger. Do not completely remove the trocar until both implants have been placed. The trocar is withdrawn only to the mark closest to its tip.

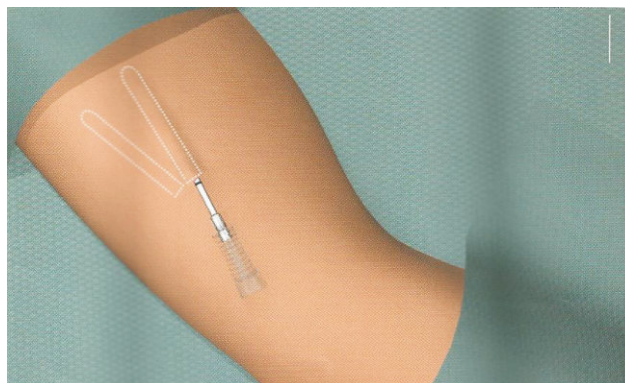
**Figure 5.2.7: Holding the plunger steady and pulling the trocar to the mark near the tip**



**Note:** It is important to keep the plunger steady and not to push the implant into the tissue

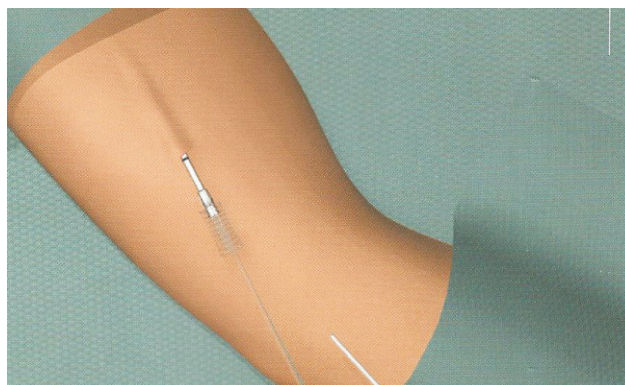
- When you can see the mark near the tip of the trocar in the incision, the implant has been released and will remain in place beneath the skin. You can check by palpation.
- Insert the second implant next to the first one to form a V-shape. Advancing again to the mark.

**Figure 5.2.8: Inserting the second implant. Advancing again to the mark forming a narrow “V”**



- Fix the position of the first implant with the left fore-finger and advance the trocar along the side of the finger. This will ensure a suitable distance between implants.
- Remove the plunger and load the second implant.

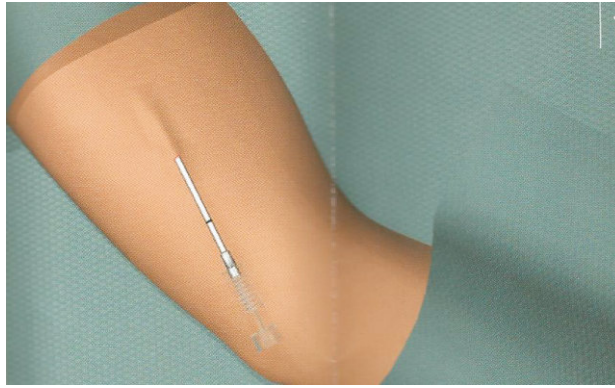
**Figure 5.2.9: Loading the second implant**



- Hold the plunger steady while pulling the trocar back (figure 5.2.10).



**Figure 5.2.10: Hold the plunger steady while pulling the trocar back**



- To prevent expulsion, leave a distance of about 5 mm between the puncture sites and the ends of the implants. Their correct position can be checked by cautious palpation of the insertion area.
- After the insertion, apply a small gauze slightly soaked in iodine solution before covering with plaster/elastoplast.

**Figure 5.2.11: Closing the incision**



**C. Instructions to the service provider following the insertion of the implants**

- ◆ The client should be observed at the clinic for 10 – 15 minutes for signs of syncope or bleeding from the incision before she is discharged.
- Before removing gloves, place instruments into a container filled with 0.5% chlorine solution for decontamination.
- The surgical drape (if used) must be washed before reuse. Place in a dry covered container and remove to the designated washing area.
- While still wearing gloves, place all contaminated objects (gauze, cotton and other waste items) in a properly marked, leak-proof container with a tight-fitting lid or in a plastic bag.
- Immerse both gloved hands briefly in chlorine solution and then carefully remove gloves by turning inside out and place in the waste container;
- Wash hands thoroughly with soap and running water.
- All waste materials should be disposed of by burning or burying

#### **D. Client Care after the procedure**

- Place a note in the client's record indicating the location of the capsules and specifying any unusual events that may have occurred during insertion. (A simple drawing showing the approximate location of the capsules in the client's arm is helpful).
- Observe the client for at least 15 to 20 minutes for bleeding from the incision or adverse effects before sending her home. She should be given written post insertion care instructions (if available) as appropriate.

#### **E. Client's instructions for wound care at home**

- There may be bruising, swelling or tenderness at the insertion site for a few days. This is normal.
- Keep the area around the insertion site dry and clean for at least 48 hours. The incision could become infected if the area gets wet while bathing.
- Leave the gauze pressure and plaster in place for 48 hours and the band-aid or surgical tape in place until the incision heals (i.e. normally 3 to 5 days).
- Routine work can be done immediately. Avoid bumping the area, carrying heavy loads or applying unusual pressure to the site.
- After healing, the area can be touched and washed with normal pressure.
- If signs of infection occur, such as fever with inflammation (redness plus heat) at the site, or if there is persistent arm pain for several days, return to the clinic.

#### **F. Schedule follow-up appointments with the clients after the procedure**

- ◆ Instructions on "Follow-up Visits" are as follows:

##### *First visit (3 – 5 days after insertion)*

- Ask the client about her health generally;
- Inspect the wound at the insertion site.
- Ask about any complaints

##### *Third Month after insertion*

- Ask about variations in her menstrual cycle, including inter-menstrual bleeding or spotting and excessive blood loss.

*Schedule of subsequent follow-ups (if all is well):*

- Ask about variations in her menstrual cycle, including inter-menstrual bleeding or spotting and excessive blood loss.
- Yearly visits until the client wishes to have the device removed or the life span of the device expires – at 5 years
- Repeat the activities of first visit at each subsequent visit;
- Encourage a pap smear every two years

**G. Summary**

- Insertion techniques involve paying attention to asepsis, anaesthesia, as well as the length and location of the puncture site.
- Careful subdermal placement ensures easy removal thereafter.
- Standard insertion techniques are similar for Jadelle while Implanon has a single use pre-loaded applicator as will be discussed in the next session.

## **Module Five- Session 3: Implanon<sup>R</sup> (Classic) and Implanon NXT<sup>TM</sup> Contraceptive Implants Insertion Techniques**

### **Learning Objectives**

By the end of this session, participants should be able to:

- State the timing of insertion of Implanon<sup>R</sup> and Implanon NXT<sup>TM</sup> implants with regard to menstruation, postpartum, post abortion and lactation periods.
- Identify the equipment and materials for Implanon<sup>R</sup> and Implanon NXT<sup>TM</sup> Implants' insertion procedures.
- Demonstrate the correct insertion technique with regard to asepsis, anaesthesia, location of incision, and careful correct placement of the implants.
- Demonstrate the unique insertion techniques of Implanon<sup>R</sup> (classic) and Implanon NXT<sup>TM</sup> implants.
- Demonstrate the correct application of dressing after insertion.
- Explain the instructions to be given to clients after insertion.
- Schedule follow-up appointments with the clients after the procedure.

### **Session Overview**

- Equipment and materials for Implanon<sup>R</sup> and Implanon NXT<sup>TM</sup> implants insertion procedures.
- Timing of insertion with regard to menstruation, postpartum, post abortion and lactation periods.
- Demonstration of the correct insertion technique for Implanon<sup>R</sup> implants with regard to asepsis, anaesthesia, location of incision, and careful correct placement of the implants.
- Demonstration of the correct application of dressing after insertion.
- Instructions to be given to clients after insertion.
- Scheduling follow-up appointments with the clients after the procedure.

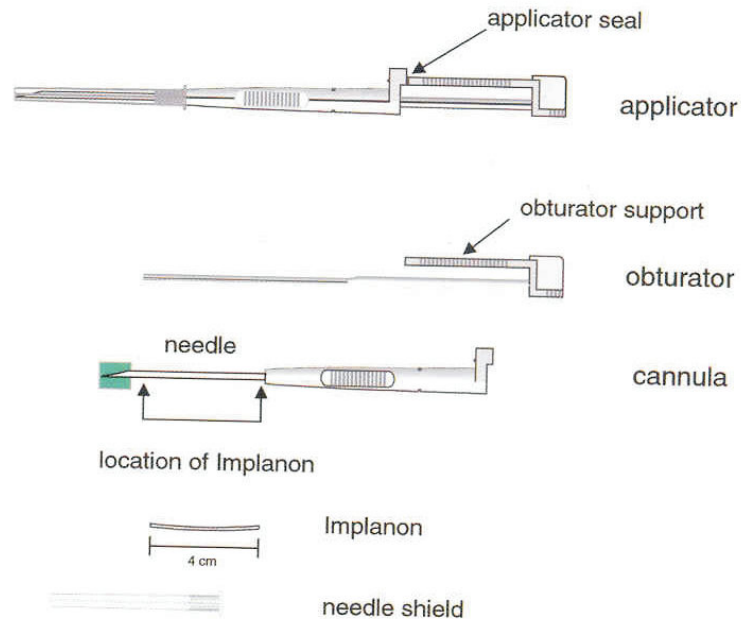
## **CONTENT**

### **A. Introduction**

#### **Timing of insertion with regard to menstruation, postpartum, post-abortion and lactation periods.**

- Only a physician who is familiar with the procedure of Implanon (classic) and Implanon NXT<sup>TM</sup> insertion should undertake the procedure and it must be done under aseptic conditions.
- Both the insertion of Implanon and Implanon NXT<sup>TM</sup> implants are performed with the specially designed applicator (Figure 4.3.1 and 4.3.2).

**Figure 4.3.1: Components of an Implanon Applicator**



- When inserting Implanon, the obturator must remain fixed while the cannula (needle) is retracted from the arm. For normal injections the plunger is pushed and the body of the syringe remains fixed.

**B. Equipment and materials for Implanon Implants insertion procedures.**

*Materials required for Implanon and Implanon NXT™ insertion*

- One set of implant capsules
- Examining table for the patient to rest her arm on
- Sterile cloth (1)
- Marker pen (2)
- Antiseptic solution (3)
- Sterile gloves (4)
- Local anaesthetic spray, or injection of 1 ml lidocaine [Xylocaine] (5)
- Preloaded, sterile Implanon applicator containing a single rod (6)
- Sterile gauze and compress (7)

**C. Correct insertion technique with regard to asepsis, anaesthesia, location of incision, and careful correct placement of the Implanon<sup>R</sup> (classic) and Implanon NXT™ Implants**

*Client Preparation*

- Give clear information about probable changes in bleeding pattern during the menstrual cycle and other possible side effects;
- Describe the insertion and removal procedures and what the client should expect during and afterwards;
- Ensure client's cooperation and relaxation;

- Review client assessment data to determine if the client is an appropriate candidate for Implanon<sup>R</sup> implants or if she has any problems that should be monitored more frequently while the implants are in place;
- Do a general examination;
- Do a pelvic examination if needed or requested by client (pelvic examinations are not necessary for safe implant initiation and use, but may be indicated for other reasons and are part of the preventive medicine practices and health promotion);
  - Instruct the client to lie on the couch with arm stretched out comfortably
  - Support arm with arm rest
  - Use proper infection prevention procedure
  - Wash hands with soap and running water
  - Ask the patient to lie down on the examination table with her non-dominant arm extended on a sterile cloth on the other table, at right angles to her body.
  - Clean the area of insertion with antiseptic solution: iodine (if available) and finally with spirit
  - Apply sterile drapes exposing the insertion area only (under the skin of the upper arm).

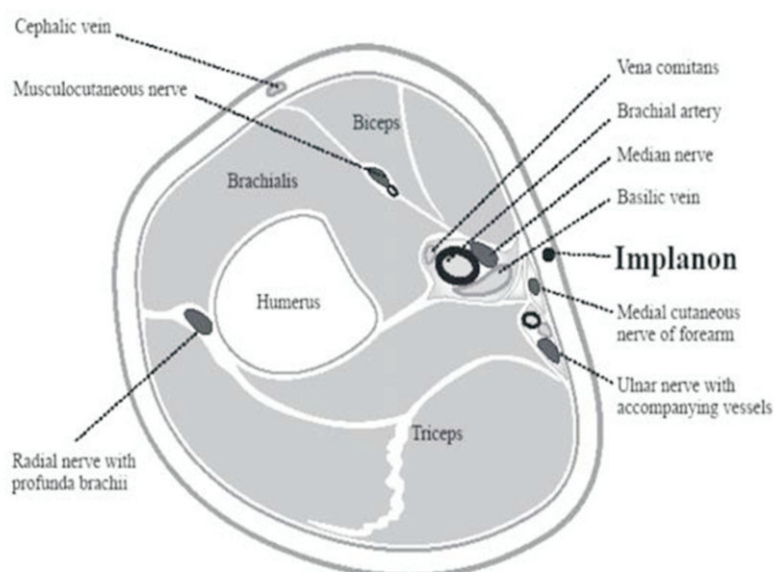
**Figure 5.3.2: Materials Required for Implanon and Implanon NXT™ Insertion**



**D. Correct insertion technique with regard to asepsis, anaesthesia, location of incision, and careful correct placement of the *Implanon*<sup>R</sup> (classic):**

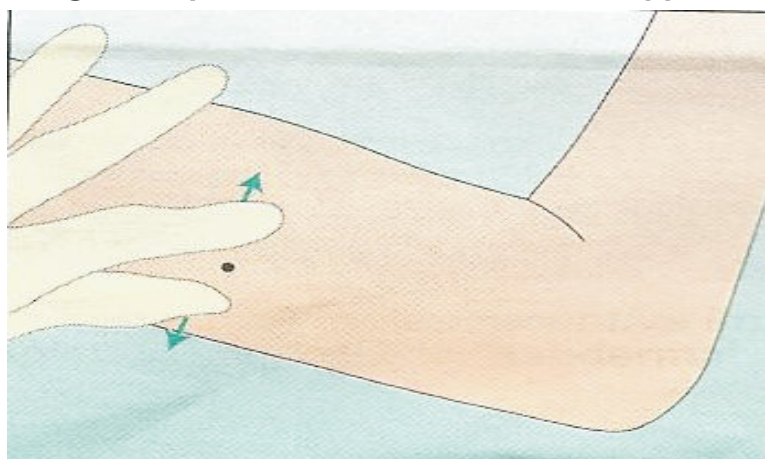
- Allow the subject to lie on her back with her non-dominant arm (the arm which the woman does not use for writing) turned outwards and bent at the elbow. If preferred, a sitting position can be taken.
- Arrange the materials and instruments so that they are accessible.
- To minimize the risk of neural or vascular damage, Implanon should be inserted at the inner side of the upper arm (non-dominant arm) about 6-8 cm above the elbow crease in the groove between the biceps and the triceps (*sulcus bicipitalis medialis*).

**Figure 5.3.3: Correct subdermal placement of Implanon**



**Note:** When Implanon is inserted too deeply (intramuscularly or in the fascia) this may cause neural or vascular damage. Too deep insertions have been associated with paraesthesia (due to neural damage) and migration of the implant (due to intramuscular or fascial insertion), and in rare cases with intravascular insertion. Moreover, when the implant is inserted too deeply, it may not be palpable and the localization and/or removal can be difficult later on.

**Figure 5.3.4: Inserting the implant at the inner side of the upper arm**



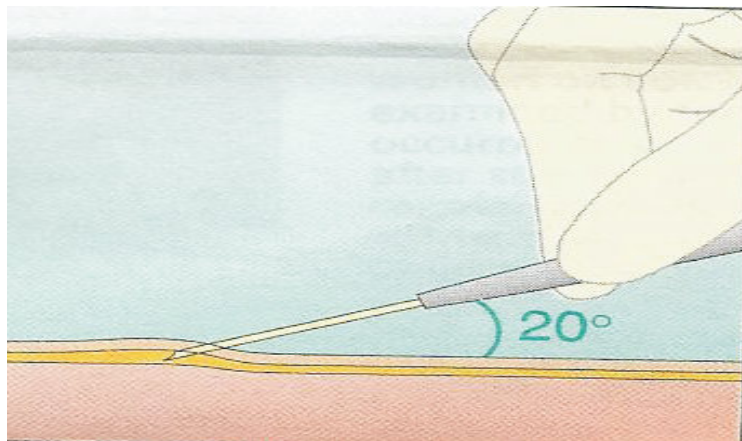
- Mark the insertion site.
- Prepare the insertion site with a cotton swab soaked with antiseptic.
- Anaesthetize with an anaesthetic spray, or with 2ml of lidocaine without adrenaline (Xylocaine 1%) applied just under the skin along the “insertion canal.”
- Carefully remove the sterile disposable applicator carrying the Implanon from its blister.
- While keeping the shield on the needle, visually verify the presence of the implant, seen as a white body inside the needle tip. If the implant is not seen, tap the top of the needle shield against a firm surface to bring the implant into the needle tip, following visual confirmation, the implant should be lowered back into the needle by doing the opposite. The needle shield can now be removed.

Note: The implant can fall out the needle prior to insertion. Therefore, always hold the applicator in the upward position (i.e., with the needle pointed upwards) until the time of insertion. This is to prevent the implant from dropping out.

Keep the needle and the implant sterile. If contamination occurs, a new package with a new sterile applicator must be used.

- Always hold the applicator in the upward position (i.e. with the needle pointed upward) until the time of insertion. This prevents the implant from dropping out.
- Stretch the skin around the insertion site with thumb and index finger (Figure 5.3.4 above).
- Insert first only the tip of the needle, slightly angled ( $20^{\circ}$ ).

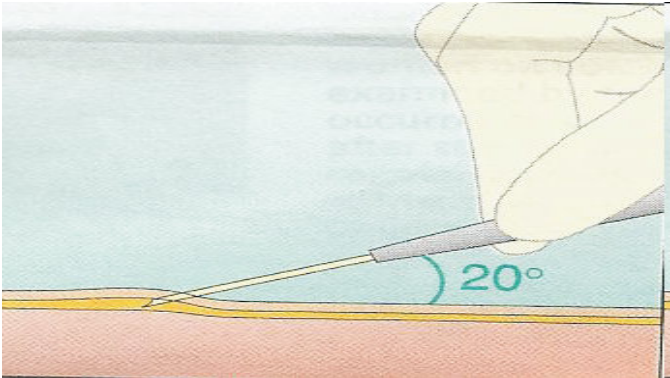
**Figure 5.3.5: Inserting the needle at  $20^{\circ}$**



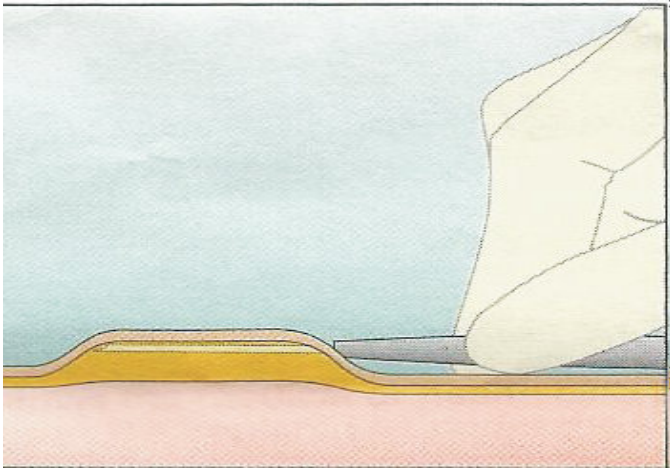
- Release the skin.
- Lower the applicator to a horizontal position (Figure 5.3.6)
- Lift the skin with the tip of the needle, but keep *the needle in the subdermal* connective tissue.
- Gently insert, while lifting the skin, the needle to its full length without using force to ensure superficial insertion (Figure 5.3.6).
- Keep the applicator parallel to the surface of the skin
- Break the seal of the applicator (Figure 5.3.7).
- Turn the obturator  $90^{\circ}$  (Figure 5.3.8).



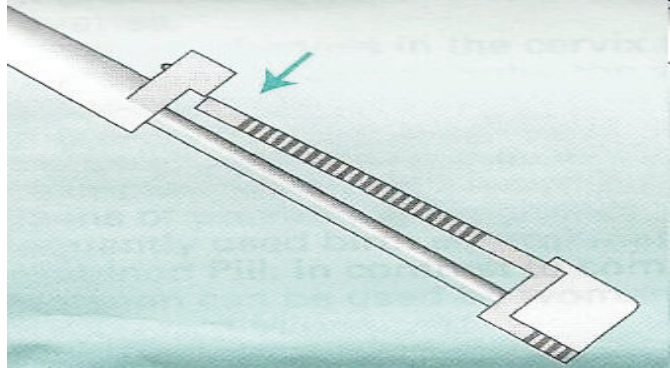
**Figure 5.3.6: Lowering the applicator to the horizontal position**



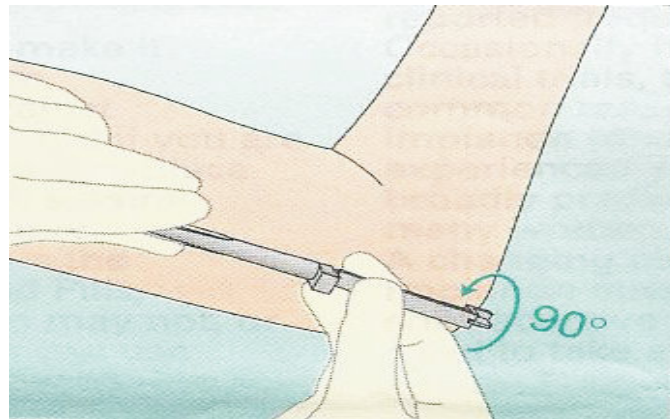
**Figure 5.3.7: Lifting the skin with the needle during insertion**



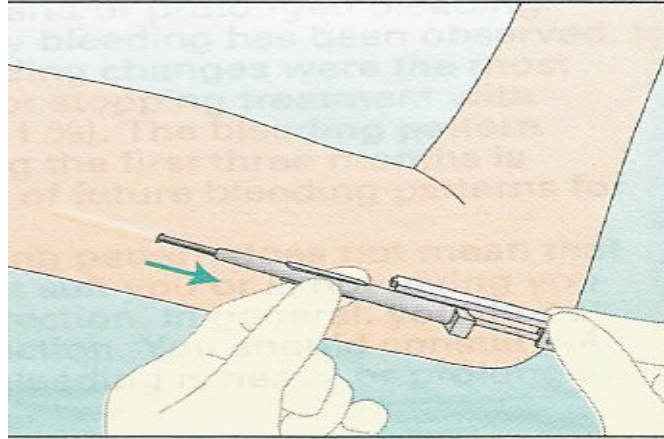
**Figure 5.3.8: Breaking the seal of the applicator**



**Figure 5.3.9: Turning the obturator 90 degrees**



**Figure 5.3.10: Retracting the cannula (needle) out of the skin**



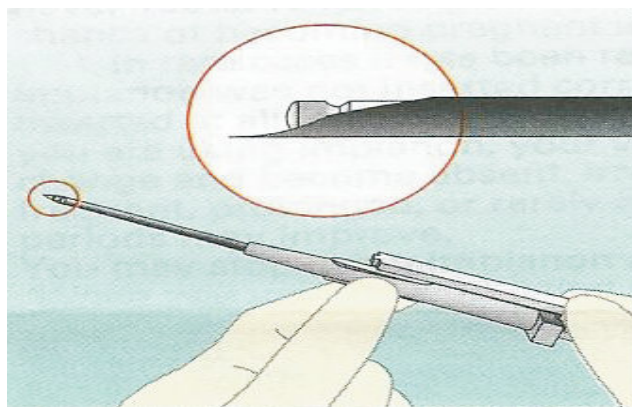
**Note:** Never push against the obturator.

- Check the needle for the absence of the implant. Do not confuse the protruding end of the obturator with the implant (same colour). (Figure 5.3.10)

**Note:** This procedure is opposite to giving an injection, where the plunger is pushed and the syringe is fixed. By keeping the obturator in its place and simultaneously pulling the cannula, the implant will remain in the upper arm.

- Always verify the presence of the implant by palpation and have the woman palpate it herself.
- Apply sterile gauze with a pressure bandage to prevent bruising

**Figure 5.3.11: Checking the needle for the absence of the implant.**



**Note:** In case the implant cannot be palpated or when the presence of the implant is doubtful, other methods must be applied to confirm its presence. Suitable methods to locate the implant are, first of all, ultrasound (USS) and secondly, magnetic resonance imaging (MRI). Prior to the application of USS or MRI for the localization of Implanon, it is recommended that Organon be consulted for instructions. In case these imaging methods fail, it is advised to verify the presence of the implant by measuring the etonorgestrel level in a blood sample of the subject. In this case Organon will also provide the appropriate procedure.

Until the presence of Implanon has been confirmed, a contraceptive barrier method must be used.

- Apply sterile gauze with a pressure bandage to prevent bruising.
- ◆ The Trainer provides the participants with clear instructions regarding *Waste Disposal and Decontamination* as follows:
  - Properly discard the Implanon<sup>R</sup> Inserter.
  - Before removing gloves, place any used instrument into a container filled with 0.5% chlorine solution for decontamination.
  - The surgical drape (if used) must be washed before reuse. Place in a dry covered container and remove to the designated washing area.
  - While still wearing gloves, place all contaminated objects (gauze, cotton and other waste items) in a properly marked, leak-proof container with a tight-fitting lid or in a plastic bag.
  - Immerse both gloved hand briefly in chlorine solution and then carefully remove gloves by turning inside out and place in the waste container;
  - Wash hands thoroughly with soap and running water.
- Fill out the User Card and hand it over to the subject to facilitate removal of the implant later on (Fill also the client's record which is kept in the facility).

**Note:** The applicator is for single use only and must be adequately disposed of in accordance with local regulations governing the handling of biohazardous waste

**E. Demonstrate the correct insertion technique with regard to asepsis, anaesthesia, location of incision, and careful correct placement of the Implanon NXT™**

- Implanon<sup>R</sup> is a subdermal, long-acting hormonal contraceptive, effective for up to 3 years.
- It is a progestin-only implant preloaded in a disposable applicator
- Implanon NXT™ is radiopaque and comparable to Implanon<sup>R</sup>.
- It has a preloaded, sterile applicator which is for single use and disposable. Inserters familiar with the applicator for Implanon<sup>R</sup> need to familiarize themselves with the one for Implanon NXT™

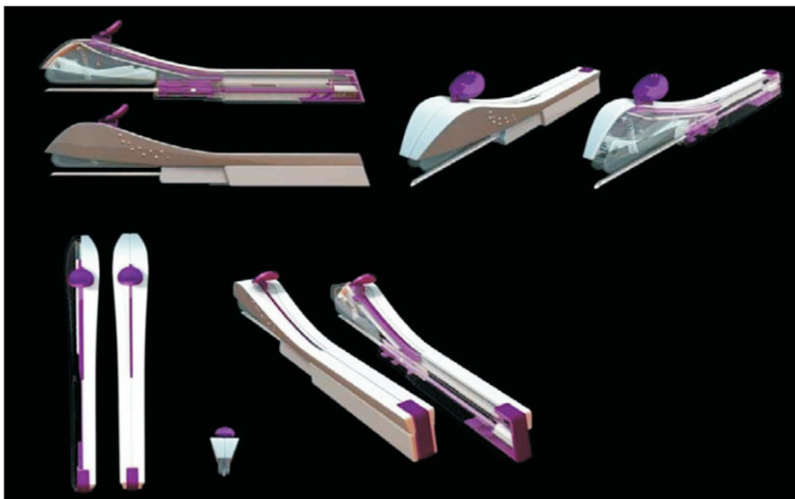
**Figure 5.3.12: Applicators of Implanon NXT™ and Placebo**



**Implanon NXT™**

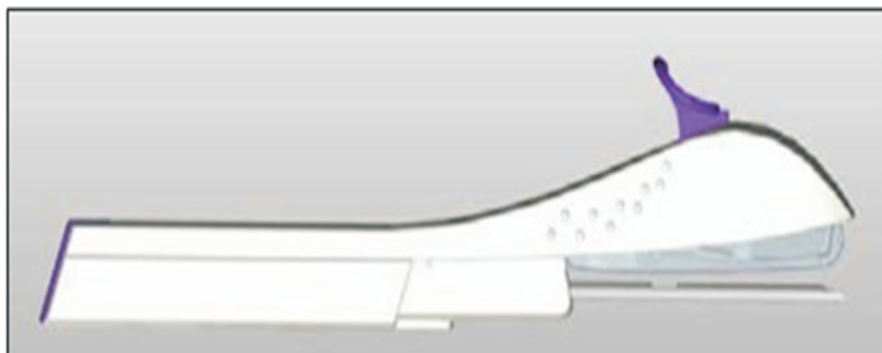
**Placebo**

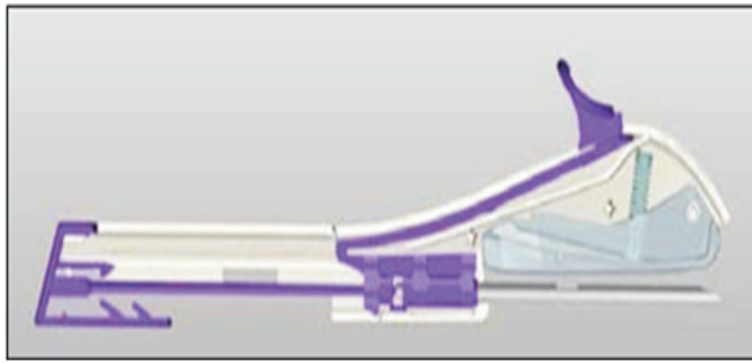
**Figure 4.3.13: Implanon NXT™ Applicators viewed from different angles**



**Implanon NXT™ Applicator design elements include:**

- Cap-blocking mechanism with cap/lever
- Implant retained in needle before insertion
- Single-handed movement with slider
- Needle partly visible
- Preloaded for single use only

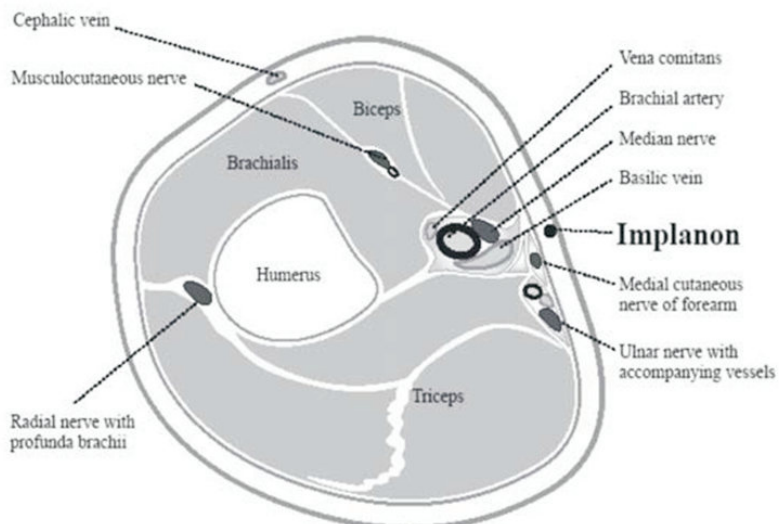




### Preparation for insertion

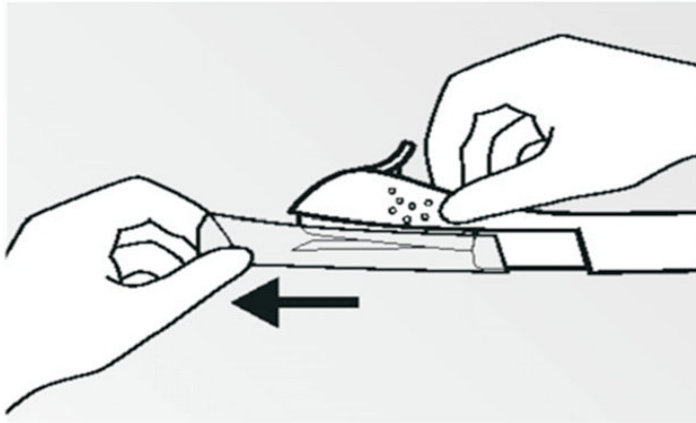
- Insertion of IMPLANON NXT™ should be performed under aseptic conditions
- Insertion of the implant should only be performed with the preloaded applicator
- It is recommended that the health care provider performs the procedure in a sitting position
- Confirm no allergies to antiseptic and anesthetic
- Allow the woman to lie on her back with her non-dominant arm turned outwards and bent at the elbow
- To minimize the risk of neural or vascular damage, the implant should be inserted subdermally at the inner side of the non-dominant (arm less commonly used) upper arm about 8-10 cm above the medial epicondyle of the humerus in order to avoid the large blood vessels and nerves that lie deeper in the subcutaneous tissue in the sulcus between the triceps and biceps muscles

**Figure 5.3.14: Correct Placement of Implanon NXT™ Subdermally**



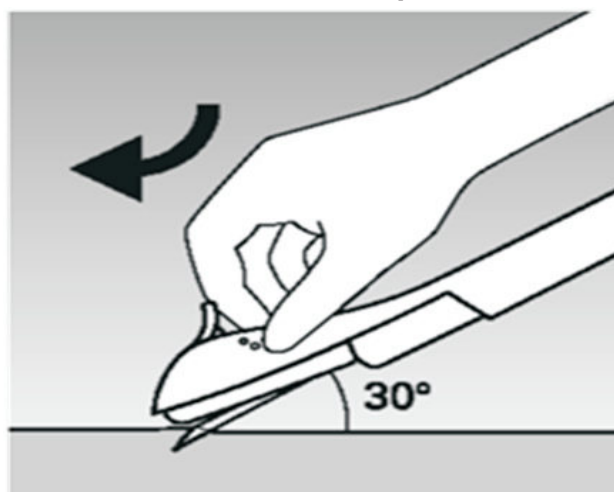
- Make 2 marks: one at insertion site and a second one a few centimeters above the insertion site to be used as direction guide during insertion
- Clean the insertion site with an antiseptic
- Anesthetize the insertion area (for example, with anesthetic spray or by injecting 2 ml of 1% lignocaine just under the skin along the planned insertion tunnel)
- Remove the sterile disposable applicator carrying the implant from its blister

**Figure 5.3.15: Removing the sterile disposable applicator carrying the implant from its blister**



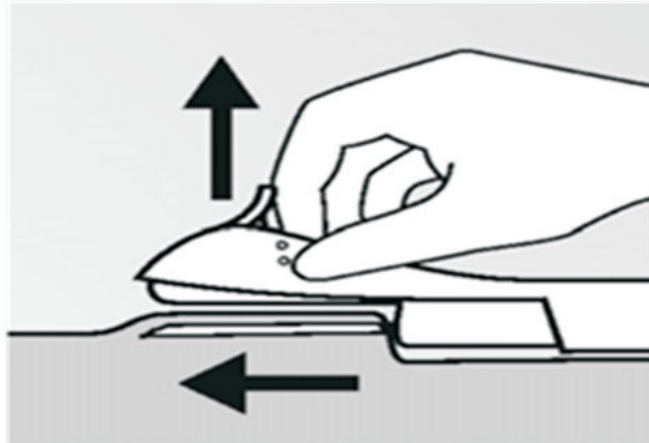
- **Keep the needle and the implant sterile** (if contamination occurs, a new package with a new sterile applicator must be used)
- **Implanon NXT™ should be inserted subdermally**
  - If the implant is inserted too deeply, neural or vascular damage may occur. Too deep or incorrect insertions have been associated with paresthesia (due to neural damage) and migration of the implant (due to intramuscular or fascial insertion), and in rare cases with intravascular insertion. Moreover, when the implant is inserted too deeply, it may not be palpable and the localization and/or removal can be difficult.
- Hold the applicator just above the needle at the textured surface area and remove the transparent protection cap from the needle which contains the implant
- **If the cap does not come off easily the applicator should not be used and must be replaced.**
- You may see the white colored implant by looking into the tip of the needle
- **Do not touch the purple slider until you have fully inserted the needle subcutaneously, as it will retract the needle and release the implant from the applicator**
- Stretch the skin around the insertion site with thumb and index finger
- Puncture the skin with the tip of the needle angled about 30°

**Figure 5.3.16: Puncture the skin with the tip of the needle angled about 30°**



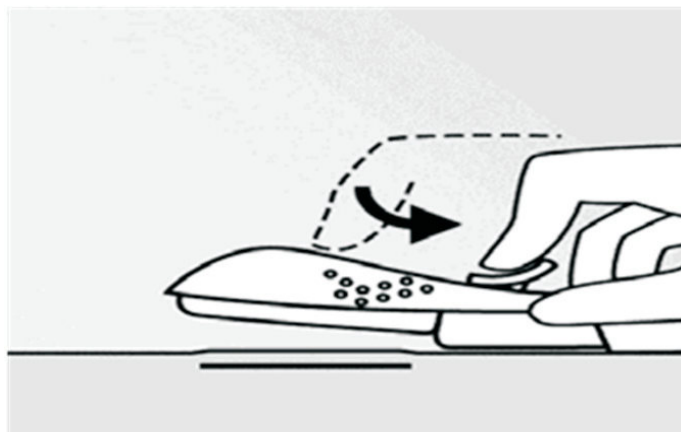
- **During the entire insertion procedure you should be able to see the insertion site and the movement of the needle**
- Lower the applicator to a horizontal position
- While lifting the skin with the tip of the needle, slide the needle to its full length

**Figure 5.3.16: Sliding the needle to its full length**



- You may feel slight resistance but do not exert excessive force
- If the needle is not inserted to its full length, the implant will not be inserted properly
- While keeping the applicator in the same position and the needle inserted to its full length, unlock the purple slider by pushing it slightly down

**Figure 5.3.17: Unlocking the purple slider by pushing it slightly down**



- Move the slider fully back until it stops, leaving the implant now in its final subdermal position and locking the needle inside the body of the applicator
- Now the implant is in its final subdermal position
- Inserting the needle to its full length is crucial; failure to do so will result in a partly visible implant protruding from the skin
- If partial protrusion occurs, discard the implant and reinsert a new sterile implant using a new applicator
- Remove the applicator

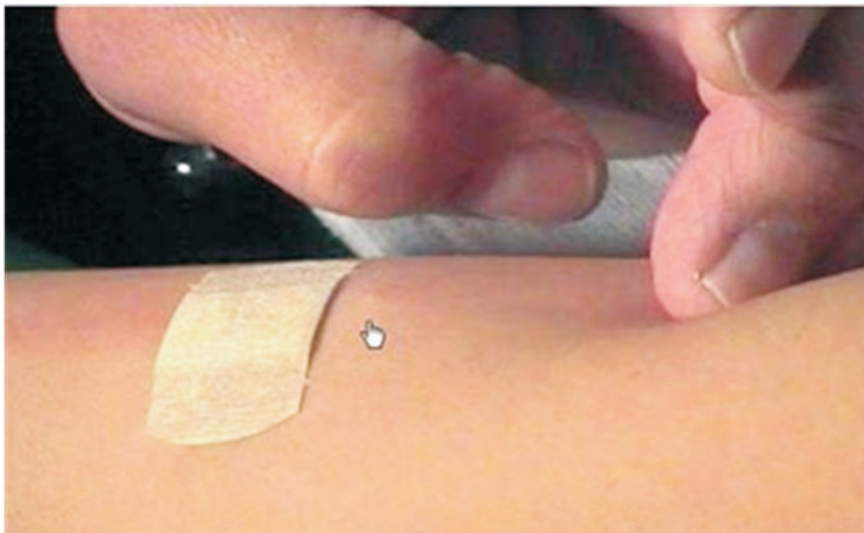
#### **E. Post-Insertion Steps**

- Apply a small adhesive bandage over the insertion site
- Apply a sterile gauze with a pressure bandage to minimize bruising. The woman may remove the pressure bandage after 24 hours and the small bandage after 3-5 days
- Complete the User Card and give it to the woman to keep and complete the adhesive labels and affix to the woman's medical record
- The applicator is for single use only and must be disposed of by the inserting physician in accordance with local regulations for biohazardous waste

### *Confirmation immediately after insertion*

- Always **verify the presence of the implant by palpation**
- If the implant is not palpable, confirm its presence in the arm with imaging techniques as soon as possible
- The woman must use a backup method of contraception until the presence of the implant has been confirmed

**Figure 5.3.18: Confirmation of the implant immediately after insertion**



- ◆ The following are instructions regarding *Waste Disposal and Decontamination*:
  - Properly discard the Implanon NXT™ Applicator.
  - Before removing gloves, place any used instrument into a container filled with 0.5% chlorine solution for decontamination.
  - The surgical drape (if used) must be washed before reuse. Place in a dry covered container and remove to the designated washing area.
  - While still wearing gloves, place all contaminated objects (gauze, cotton and other waste items) in a properly marked, leak-proof container with a tight-fitting lid or in a plastic bag.
  - Immerse both gloved hand briefly in chlorine solution and then carefully remove gloves by turning inside out and place in the waste container;
  - Wash hands thoroughly with soap and running water.
  - Fill out the User Card and hand it over to the subject to facilitate removal of the implant later on (Fill also the client's record which is kept in the facility).
- **If you cannot feel the Implant or in doubt of its presence:**
  - Check the applicator. The needle should be fully retracted and only the purple tip of the obturator should be visible. In any other case, the insertion must be considered to not have been complete



- Use other methods to confirm the presence of the implant presence in the arm. Suitable methods are: **two-dimensional X-ray, ultrasound scanning (USS)** with a high-frequency linear array transducer (10 MHz or greater), computerized tomography (**CT scan**), or magnetic resonance imaging (**MRI**). Prior to the application of X-ray, USS, CT, or MRI for the localization of the implant, it is recommended, to consult the local supplier of Implanon NXT™ for instructions
- In case these imaging methods fail, it is advised to verify the presence of the implant in the arm by measuring the etonogestrel level in a blood sample of the subject. In this case the local supplier will provide the appropriate procedure
- **Until you have verified the presence of the implant, a non-hormonal contraceptive method must be used**

## G. Instructions to be given the clients after insertion

### *Client Care*

- Place a note in the client's record indicating the location of the capsules and specifying any unusual events that may have occurred during insertion. (A simple drawing showing the approximate location of the capsules in the client's arm is helpful).
- Observe the client for at least 15 to 20 minutes for bleeding from the incision or adverse effects before sending her home. She should be given written post insertion care instructions (if available) as appropriate.

### *Client's instructions for wound care at home*

- There may be bruising, swelling or tenderness at the insertion site for a few days. This is normal.
- Keep the area around the insertion site dry and clean for at least 48 hours (use cellophane protection during baths). The site could become infected if the area gets wet while bathing.
- Leave the gauze pressure and plaster in place for 48 hours and the band-aid or surgical tape in place until the incision heals (i.e. normally 3 to 5 days).
- Routine work can be done immediately. Avoid bumping the area, carrying heavy loads or applying unusual pressure to the site.
- After healing, the area can be touched and washed with normal pressure.
- If signs of infection occur, such as fever with inflammation (redness plus heat) at the site, or if there is persistent arm pain for several days, return to the clinic.

## **H. Schedule follow-up appointments with the clients after the procedure**

### *First visit (3– 5 days after insertion)*

- Ask the client about her health generally;
- Inspect the wound at the insertion site.
- Ask about any complaints

### *Third Month after insertion*

- Ask about variations in her menstrual cycle, including inter-menstrual bleeding or spotting and excessive blood loss.

### *Schedule of subsequent follow-ups (if all is well):*

- Ask about variations in her menstrual cycle, including inter-menstrual bleeding or spotting and excessive blood loss.
- Yearly visits until the client wishes to have the device removed or the life span of the device expires – at 5 years
- Repeat the activities of first visit at each subsequent visit;
- Encourage a pap smear every two years

## **I. Summary**

- As in the Jadelle Insertion techniques, attention must be paid to asepsis, anaesthesia, as well as the length and location of the puncture site.
- Careful subdermal placement ensures easy removal thereafter.
- Implanon and Implanon NXT™ have single use pre-loaded applicators unlike Jadelle implants.

## **Module Five – Session 4: IUD Removal Techniques**

### **Learning Objectives:**

By the end of this session, participants should be able to:

- Identify the indications for removal of IUD.
- Identify the equipment and materials for IUD removal procedures
- Demonstrate the correct removal techniques with regards to asepsis, and removal procedure.
- Explain what to do when difficulties arise during removal.
- List appropriate steps for reinsertion, if needed.
- Demonstrate post-removal counselling techniques.

### **Session Overview:**

- Indications for removal of IUD.
- Equipment and materials for IUD removal procedures
- Demonstration of the correct removal techniques with regards to asepsis, and removal procedure.
- What to do when difficulties arise during removal.
- Appropriate steps for reinsertion, if needed.
- Demonstration of post-removal counselling techniques

## **CONTENT**

### **A. Introduction**

#### **Indications for removal of CuT 380A IUD**

- Copper-releasing IUDs such as CuT 380A can be removed/replaced after 12 years.
- Unless an IUD is being removed for a medical reason or at the client's request, a new IUD can be inserted immediately after removing the old, if the client so desires.
- IUD removal is usually a routine, uncomplicated and painless procedure provided the provider is gentle and careful.
- For routine removals, especially if the client wants a replacement, it may be easier to remove the IUD during the menses.
- To avoid breaking the strings, the provider should apply gently, steady traction and remove the IUD slowly.
- As with IUD insertion, to minimize the risk of infection with IUD removal, the same infection prevention practices must be followed.

#### *Reasons for removal of IUD*

- Client desires pregnancy
- Menopause, no need for contraception
- Client desires another method of contraception
- Life of IUD has expired

- Accidental pregnancy
- Client is not able/willing to tolerate side effects
- Dyspareunia (painful intercourse)
- Partial expulsion of the device
- Cervical perforation
- Uterine perforation
- IUDs can be removed whenever a client insists on having it removed or when there are indications for removal.
- The best time to remove is during menses, because the cervix is slightly dilated, soft and removal is less uncomfortable.

**B. Equipment and materials for CuT 380A IUD removal procedures.**

- The instruments and equipment for removal are the same as for insertion.
- In addition, an alligator forceps and a retrieval hook should be available. All instruments should be high-level disinfected (or sterilized).

**C. Correct removal techniques with regards to asepsis.**

- Explain the removal procedure to the client to ensure her cooperation and relaxation.
- Ensure that the client has emptied her bladder
- Place the client in the dorsal position with the legs flexed at the hip and knees;
- With sterile-gloved hand, part the labia and gently pass a Cusco's speculum;
- Visualise the cervix;
- Clean the cervix and fornices with antiseptic solution;
- Tell the client that you are going to remove the IUD.
- Ask her to take slow, deep breaths and relax.
- Inform her that there may be some cramping, which is normal.
- Grasp the IUD strings near the external os with long artery forceps and apply gentle and steady traction to remove device.
- To avoid breaking the strings, apply steady, but gentle, traction and remove the IUD slowly;
- If the string break off, but the IUD is still visible, grasp the device with the forceps and remove it.
- Check that no part has broken off the device;

- Show device to the client;
- Clean the cervix with an antiseptic solution;
- Apply a perineal pad.

**NOTE:** The device can usually be removed without difficulty and excessive force should not be applied.

**D. What to do when difficulties arise during removal.**

- If traction, as described above, does not result in the removal of the device, or strings are not visible or strings are too short, refer to trained FP doctors and Nurse/Midwives

**E. Post-removal Counselling techniques for CuT 380A IUD.**

- Explain to the client that slight vaginal spotting may continue for a few days;
- If client wishes to use another method of contraception, counsel and/or initiate accordingly.

**F. Summary**

- IUD removal is usually a routine, uncomplicated and painless procedure provided the provider is gentle and careful.
- For routine removals, especially if the client wants a replacement, it may be easier to remove the IUD during the menses.
- To avoid breaking the strings, the provider should apply gently, steady traction and remove the IUD slowly.
- As with IUD insertion, to minimize the risk of infection with IUD removal, the same infection prevention practices must be followed.

## Module Five - Session 5: Implant Removal Techniques

Time: 60 minutes

### Learning Objectives

By the end of this session, the participants should be able to:

- List the indications for removal.
- Identify the equipment and materials for implant removal procedures
- Demonstrate the correct removal techniques with regards to asepsis, anaesthetic, length and location of incision, and removal procedure.
- List what to do when difficulties arise during removal.
- List appropriate steps for reinsertion.
- Demonstrate post-removal counselling techniques.

### Session Overview

- Indications for removal.
- Equipment and materials for implant removal procedures
- Demonstration of the correct removal techniques with regards to asepsis, anaesthetic, length and location of incision, and removal procedure.
- What to do when difficulties arise during removal.
- Appropriate steps for reinsertion.
- Demonstration of post-removal counselling techniques.

## CONTENT

### A. Introduction

#### Indications for removal of contraceptive implants.

- Unlike insertion, removal of implants does not have to be timed to the menses and can be done at any time.
- Correct insertion – with the capsules placed subdermally – makes the removal procedure much easier.
- While all types of clinicians (physicians, nurses and midwives) can be trained to insert and remove the capsules, a clinician skilled in removal should be consulted if difficulty in removing the capsules is anticipated.
- Service providers need to work gently, carefully and patiently when removing capsules.
- As with insertion, using the recommended practices for the prevention of infection is essential for minimizing the risk of disease transmission and infections following removal of the implants.
- Removal requires more patience and skill than insertion. Moreover, with atypically placed capsules (i.e., those inserted too deep and/or in an irregular pattern), removal using any technique takes longer and is associated with more blood loss than insertion.

#### *Indications for Removal*

##### *Medical Reasons*

- Excessive bleeding
- Pregnancy
- Jaundice

- Seizure
- Migraine
- Severe headache
- Blurred vision
- Weight problems

### *Personal Reasons*

- Planned pregnancy
- Client dissatisfaction (her reason to stop)
- At the end of 3-5 years depending on the type being used.
- The indication for removal may be personal or medical.
- Providers may perceive implants as 3-5 years method, however clients need constant reassuring that the implant may be removed at any time and for any reason.
- One of the advantages of Implant is that when the implanted capsules are removed, the woman's fertility returns to normal almost immediately.
- If the woman wishes to have the implant removed, it is important that access to removal is readily available.
- Experience shows that in some instances, where the providers have been trained to do insertion only, they may be hesitant about doing removal thus preventing easy access to removal for the client.

### *Pre-removal Counselling*

- Before removing the capsules, talk with the client about her reason for removal and answer any questions.
- Ask the client about her present reproductive goals (e.g. does she want to continue spacing or limiting births?)
- Briefly describe the removal process and what she should expect both during the removal and afterwards.

## **B. Equipment and materials for implant removal procedures**

- ◆ The equipment and materials for implant removal procedures are as follows:
  - Examining table for the woman to lie on
  - Arm support or side table
  - Soap for washing the arm
  - Sterile (or clean), dry surgical drape
  - Three bowls (one for the antiseptic solution, one for cotton balls soaked in boiled or sterile water to remove the talc from gloves and one containing 0.5% chlorine solution for decontaminating removed capsules);
  - Pairs of sterile (or high-level disinfected) surgical gloves;
  - Antiseptic solution
  - Local anaesthetic - 1% xylocaine without epinephrine (adrenaline)
  - Syringe (5 or 10 ml) and 2.5 to 4cm (1 – 1 ½ inches) long needle (22 gauge)
  - Scalpel with #11 blade
  - Curved and straight forceps (mosquito and Crile)
  - Jadelle holding forceps
  - Ordinary and straight forceps (mosquito and Crile)
  - Ordinary band-aid or sterile gauze with surgical tape or plaster
  - Sterile gauze and compresses
  - Epinephrine (Adrenaline) readily available for emergency use in anaphylactic shock.

**Figure 5.5.1: Basic items required for removal of implants**



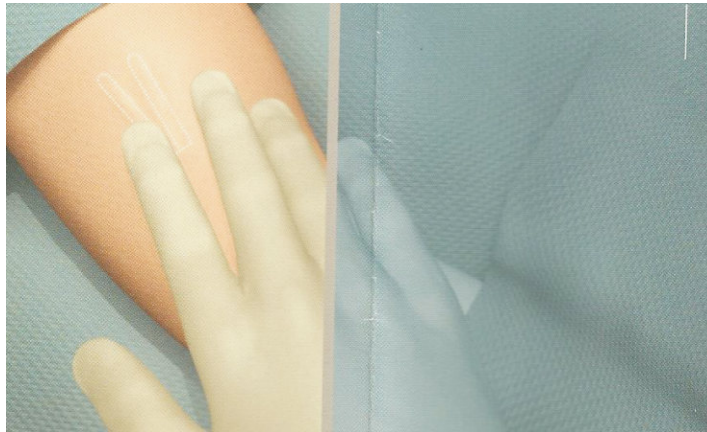
**C. Correct removal techniques with regards to asepsis.**

- Ask the client to lie on the table so that the arm with the capsules rests on the table or arm support. Her arm should be well supported and should be comfortable when extended straight or kept slightly bent, as the clinician prefers.
- Locate the two capsules Jadelle or one capsule of Implanon or Implanon NXT™ by palpation.
- To gauge where to make the incision, palpate the end of the capsule(s) with bare (ungloved) fingers. (If it is difficult to find the capsules, refer to the client's file where the original capsule placement should have been recorded and a diagram may be available.)

**TIP:** To make locating the capsules easier, moisten fingertips with a small amount of soapy water or antiseptic solution such as Betadine or Savlon. Doing this decreases friction between the clinician's fingertips and the client's skin and allows the capsules to be more easily felt.

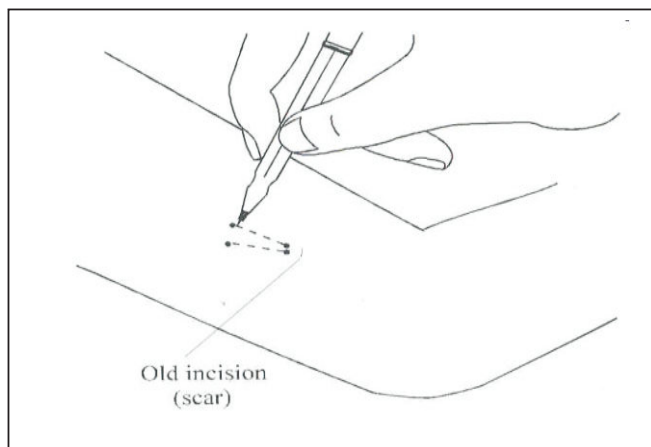


**Figure 5.5.2: Locating the Capsules by Palpation**



- Confirm the position of each capsule by making a mark at both ends of the capsules (tip) using a ballpoint or marking pen.
- Prepare an instrument tray and open the sterile instrument pack without touching the instruments and other items.
- Wash hands thoroughly with soap and water and dry them with a clean cloth.
- Put sterile or high-level disinfected gloves on both hands. (A separate pair of gloves must be worn for each client to avoid cross-contamination)

**Figure 5.5.3: Marking the Position of the Capsules**



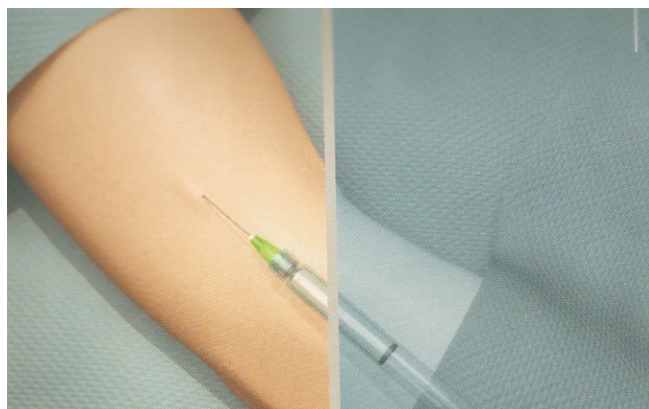
**Note:** Do not use powdered gloves. The tiny granules (talc) may fall into the removal site and cause scarring (fibrous reaction). If gloves are powdered, wipe off the fingers with sterile gauze soaked with sterile or boiled water.

- Arrange supplies and instruments so that they are easily accessible.
- Prepare the removal site with an antiseptic solution. Use a sterile or high-level disinfected sponge forceps to hold a cotton or gauze swab soaked with antiseptic solution. (If preparation is done with a gloved hand, care must be taken not to contaminate the glove by touching any unprepared skin). Begin wiping at the incision site and move outward in a circular motion for 8 to 13 cm (3 to 5 inches) and allow to air dry before proceeding. Wipe off excess antiseptic only if necessary to see pen marks.
- If a sterile surgical drape with a hole in it is available, it should be used to cover the arm. The hole should be large enough to expose the area where the capsules are located.
- Again, locate the two capsule(s) by palpating.

- After determining the absence of known allergies to the anaesthetic agent or related drugs, fill a syringe with about 3 ml of a local anaesthetic (1% Lignocaine without adrenaline).
- Insert the needle just under the skin where the incision will be made. Next pull back on the plunger to be sure the needle is not in a blood vessel (aspirate). Inject a small amount of anaesthetic to raise a small wheal (raised area).
- Gently advance the needle under the first capsule, about one third of its length (1 cm). Slowly withdraw the needle while injecting anaesthetic (about 0.5 ml) to raise the end of the capsule.

**Remember:** Correctly injecting the local anaesthetic under the tips of the capsules is critical to an easy and rapid removal.

**Figure 5.5.4: Injecting local anaesthetic under the narrow V-end of the implants**

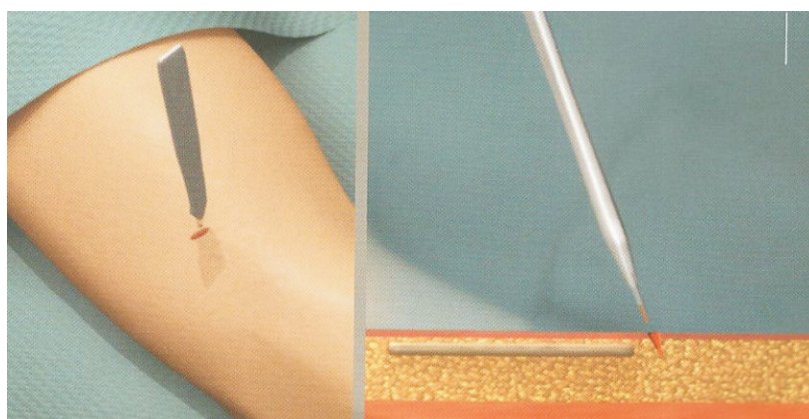


**Note:** Never put anaesthetic over the capsules because the tissue swelling makes it difficult to palpate the capsules. If necessary, additional small amounts of anaesthetic can be added as the removal process continues.

- Before starting, gently touch the incision site with the hypodermic needle or scalpel to be sure the anaesthetic is working.

**Note:** To prevent local anaesthetic toxicity the total dose should not exceed 10ml (10 grams/litre) of a 1% local anaesthetic without adrenaline.

**Figure 4.5.6: Making an incision**



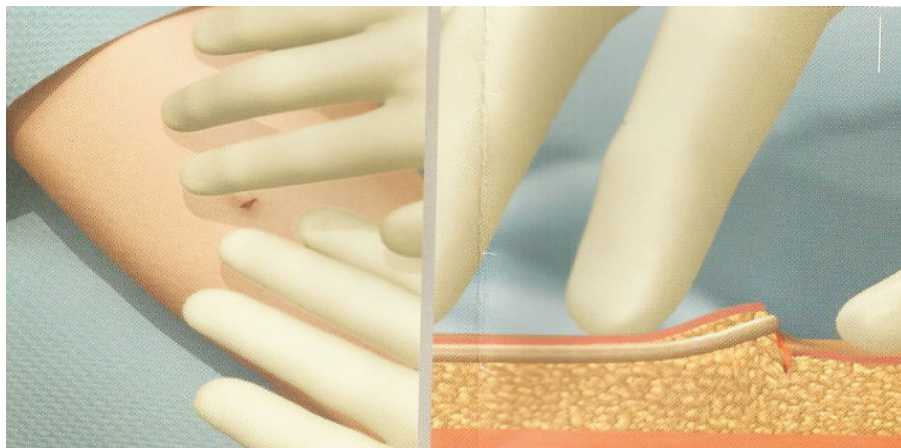
- Choose a point for the incision that is equidistant from the ends of all the capsules and which is close to and about 5 mm below the distal (toward the elbow) ends of the capsules.

- If appropriate, the removal incision may be made at the point of the previous insertion incision. Before selecting this site, however, make sure that neither of the capsule ends are under the old incision. (This avoids the possibility of cutting through the capsules)
- At the site chosen, make a small transverse incision of about 4 mm or less with a scalpel. Do not make a large incision.

**Note:** If another set of capsules is to be inserted, usually the same incision can be used for both removal and insertion of a new set (see Second Insertion in this module).

- **Begin by selecting the capsule closest to the surface or nearest the incision.**
- Push the tip of the capsule gently toward the incision with the gloved fingers of one hand until it can be seen at the incision. When the tip is visible in the incision, insert the curved forceps (mosquito or Crile) with the jaws curving up and grasp the end of the capsule.

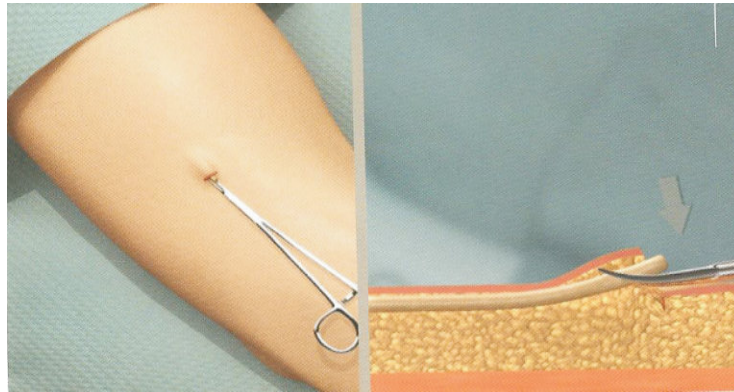
**Figure 5.5.6: Pushing the implant with the fingers gently towards the incision**



**Note:** If the capsules cannot be easily moved into the incision, this may be due to scarring (fibrous tissue formation) around the tips of the capsules.

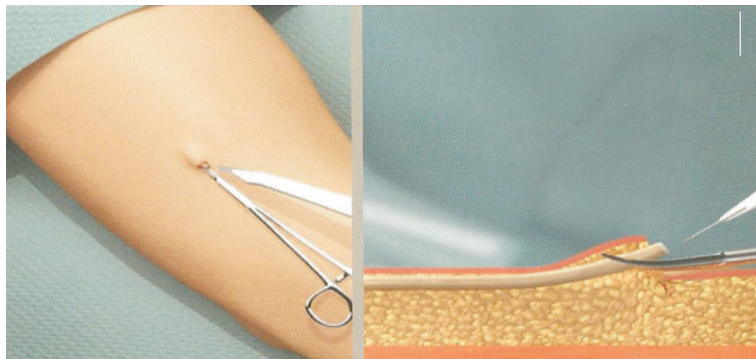
- Insert the curved forceps through the incision with the jaws pointed up toward the skin and advance until they are below the ends (tips) of the capsules nearest the elbow.
- Then open and close the forceps jaws (blunt dissection) to break up the scar tissue surrounding the tip of the capsule. Repeat until the tips of the two capsules are free (easily moveable).
- Next, push the tip of the first capsule as close to the incision as possible. While pressing on (stabilizing) the capsule with the first (forefinger) and middle fingers of one hand.
- Re-insert the curved forceps under the end of the capsule (jaws pointing up toward the skin)
- Grasp the capsule near the tip (5 to 10mm) and gently pull it into the incision

**Figure 5.5.7: Inserting the curved mosquito forceps**



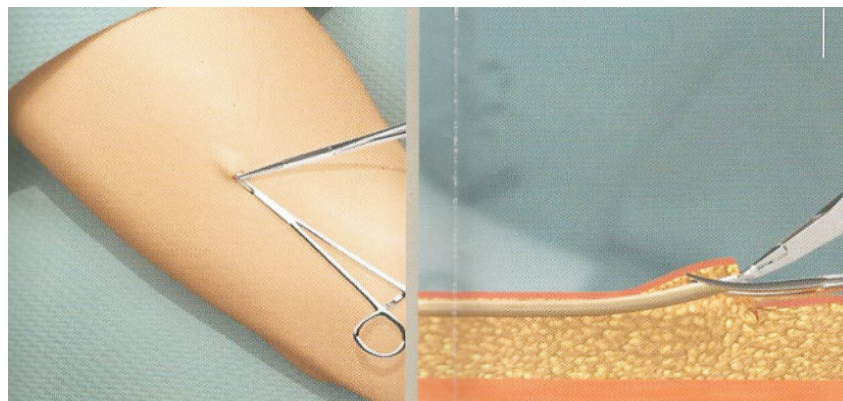
- Clean off and open the fibrous tissue sheath surrounding the capsule by rubbing vigorously with sterile gauze to expose the tip of the capsule.

**Figure 5.5.8: Opening the tissue capsule**



- Alternatively, if rubbing the fibrous tissue sheath will not open it, the scalpel can be used). To avoid cutting the capsule, use the backside (non-sharp edge) of the scalpel
- Grasp the freed tip of the capsule with a second pair of forceps. Release the first forceps and slowly and gently remove the capsule with the second forceps.

**Figure 5.5.9: Grasping the end of implant with the Mosquito artery forceps**

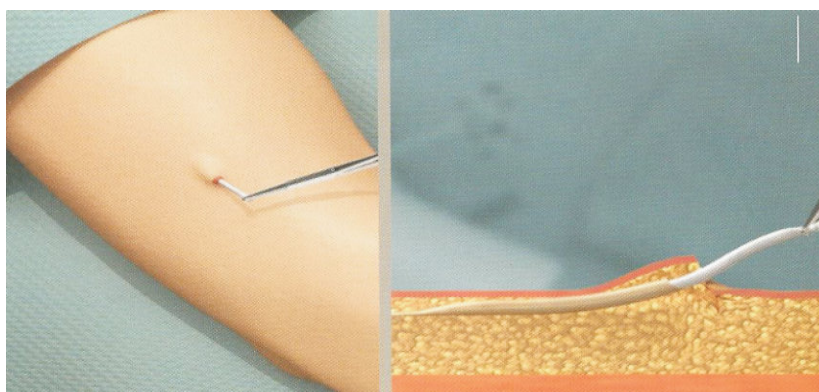


- Since tissue usually does not adhere to silicone rubber, the capsule should slide out easily. If for some reason the capsule does not come out easily, remove any remaining fibrous tissue from the capsule by gently rubbing with sterile gauze or scarping with the scalpel blade.

*Note: As capsules are removed, place them in a small bowl containing 0.5% chlorine solution for decontamination prior to disposal. In addition, by looking at the capsules in the bowl, the clinician can tell whether or not the capsules are broken – undamaged capsules will float; broken capsules will sink gradually to the bottom.*

- If additional anaesthetic is required, inject it only under the capsule so as not to obscure them.

**Figure 5.5.10: Release the mosquito forceps and remove the implant gently**



- Repeat using the same technique to remove the remaining capsule.
- It is important to show the client all six capsules to reassure her.

**Figure 5.5.11: Be sure that both implants (for Jadelle and 1 implant for Implanon<sup>R</sup> and Implanon NXT<sup>TM</sup>) are removed**



*Procedures to be followed immediately after removal of implant:*

*Covering the Incision.*

- If the client does not want another set of implants, clean the area around the incision site with a small amount of antiseptic solution applied to a cotton or gauze swab.
- Use the forceps to hold the edges of the incision together briefly (10 to 15 seconds). This will help reduce bleeding from the incision. Then apply gauze soaked in slight iodine solution to the incision area.
- With the edges of the incision together, close with a band-aid, or surgical tape with sterile cotton. Sutures are not necessary and may increase scarring. Check for any bleeding.

### *Waste Disposal Decontamination*

- Before removing gloves, gently place instruments into a container filled with a 0.5% chlorine solution for decontamination. Soak all items for 10 minutes, then rinse immediately with clean water to avoid discoloration or corrosion of metal items.
- While still wearing gloves, place all contaminated objects (capsules, gauze, cotton and other waste items) in a properly marked, leak-proof container with a tight-fitting lid or in a plastic bag.
- Immerse both gloved hands briefly in chlorine solution and then carefully removed gloves by turning inside out and place in the waste container.
- Wash hands thoroughly with soap and water
- All waste material should be disposed of by burning or burying.
- ◆ The provider should observe the client at the clinic for 10 – 15 minutes for signs of syncope or bleeding from the incision before she is discharged.

### **D. What to do when difficulties arise during removal of implants.**

#### *Removing Hard-to-Retrieve Capsules*

- For hard to remove capsules, only trained FP physician and nurses/midwives should conduct the procedure. REFER.

### **E. Appropriate steps for re-insertions.**

- The capsules may be placed through the same incision in the same general direction as the previous set.
- Alternatively, the capsules can be inserted in the opposite direction. Be sure the tips of the capsules do not lie so close to the elbow fold as to interfere with movement.
- A new incision should be necessary only if there is too much soft tissue trauma (bruising) in the area of the original insertion or if there is not enough room between the incision and the elbow fold.
- In the unlikely event that the removal site is unsuitable, or at the client's request, the new set can be inserted in the other arm.

### **F. Post-removal Counselling techniques for implants**

#### *Client Care*

- Place a note in the client's record indicating the date of removal and specifying any unusual events that may have occurred during removal
- Observe the client for at least 15 to 20 minutes for bleeding from the incision or adverse effects before sending her home.

### *Client Instructions for Wound Care at Home*

- There may be bruising swelling or tenderness at the insertion site for a few days. Clients should be reassured that this is normal.
- Keep the area around the removal site dry and clean for at least 48 hours. (The incision could become infected if the area gets wet while bathing)
- If used, leave the gauze pressure and plaster in place for 48 hours and the band-aid or surgical tape in place until the incision heals (i.e. normally 3 to 5 days)
- Routine work can be done immediately. Avoid bumping the area, carrying heavy loads or applying unusual pressure to the site.
- After healing, the area can be touched and washed with normal pressure.
- If signs of infection occur, such as fever, inflammation (redness plus heat) at the site or persistent arm pain for several days, return to the clinic
- The client should be told when to come back for a follow-up visit, if needed.
- Discuss what to do if she experiences any problems. Answer any questions
- The fibrous sheaths in the arm (tracks where the capsules were located) may be felt for some time.
- This sensation will disappear within a few months.

### **G. Summary**

- Correct removal techniques involve paying proper attention to asepsis, adequate anaesthesia and appropriate location of the incision.
- The provider needs to work gently, carefully and patiently. Removal procedures take longer time than insertions.
- If difficulties are encountered during removal, **REFER**.
- Clients should always be given instructions for wound care at home on discharge.

## Module Six: Model and Clinical Practice

### Learning Objectives

By the end of this session, participants should be able to:

- Explain the rationale for the use of models during IUD and implant training
- Discuss the “Clients' Rights” during clinical training
- List the guidelines for clinical observation and practice and decorum in the clinical area
- Mention “Infection Prevention Reminders”
- Discuss the guidelines for the daily Post-practice sessions
- List the guidelines for completing the “Clinical Procedures Record Sheet”

### Session Overview

- Rationale for the use of models during IUD and implant training
- “Clients' Rights” during clinical training
- Guidelines for clinical observation and practice, and decorum in the clinical area
- “Infection Prevention Reminders”
- Guidelines for the daily Post-practice sessions
- Guidelines for completing the “Clinical Procedures Record Sheet”

## CONTENT

### A. Rationale for the use of models during IUD and implant insertion (15 minutes)

This module includes guidance on the clinical practice for this training programme. Most of the participants' time will be spent on clinical practice. Since this is a competency-based course, the participants will practice IUD and Implant insertion and removal skills on models first, observe these same procedures on clients and then perform them on clients under supervision.

A major component of humanistic training is the use of anatomic models, which simulates the human body, and other learning aids such as slide sets and videotapes.

The effective use of models:

- Facilitates learning,
- Shortens training time, and
- Helps participant correct mistakes in technique that could hurt the client.

### B. Procedures that will be adopted for the clinical practice:

- Before a participant attempts a clinical procedure on a client, two learning activities should occur:
  - The clinical trainer should demonstrate the required skills and client interactions several times using an anatomic model and appropriate audiovisual aids (e.g. slide sets or videotapes).



- While being supervised, the participant should practice the required skills and client interactions using the model and actual instruments in a simulated setting which is as similar as possible to the real situation.
- The participants will practice using the Learning Guides for Clinical Skills in IUD and Implant Insertion and Removal Techniques on models;
- The trainer(s) will evaluate each participant's performance using the Observation Checklist. Once the participant passes the assessment on the model, s/he will be allowed to practice on clients.
- The final skills evaluation will be done while the participant is performing IUD and Implant Insertion and Removal Techniques on clients.
- The participants must be supervised by the trainers at all times during the clinical practice.
- The number of procedures each participant must perform on models or clients before achieving competency will vary according to the participant's skill and experience.
- Only when skill competency and some degree of skill proficiency have been demonstrated with models, however, should participants have their first contacts with clients.

### **C. “Clients' Rights” during clinical practice.**

Client safety and client satisfaction are the goals of this training in long-acting contraceptive services. Therefore, the client's rights of privacy and confidentiality are a part of clinical training.

In ensuring “Clients' Rights during Training”, the following must be noted:

- The client's permission must be obtained before any participant observer assists with or performs any services. The client should understand that she has the right to refuse care from a participant (provider-in-training) without loss or postponement of services. If the client should refuse participant-assisted or performed services, the trainer or other staff members should perform the procedure.
- Clients who consent to participate in training should be informed in advance that they will receive care from a trainee under the direct supervision of a qualified trainer.
- When conducting counselling, performing a physical examination or giving services, an environment that protects the client's bodily privacy and confidentiality of speech must be created and maintained.
- Communication between the participant and the trainer during feedback encounters or coaching must be discreet.
- Corrective feedback should be limited to situations that could harm or cause discomfort to the client.

- The client's right to confidentiality must be protected. This may be challenging to maintain strictly during training situations when specific cases are used in learning exercises. However, such discussion should take place in private areas out of hearing of other staff and clients; no reference should be made to any client by her name. Hallways, corridors, waiting areas, and other public areas are not appropriate places for discussions of clients.

#### **D. Guidelines for clinical observation and practice, and decorum in the clinical area**

The most important concerns during clinical observation/practice are ensuring the client's comfort and providing a safe, effective procedure. Achieving client's comfort and providing a safe, effective procedure requires the following guidelines:

- The operating clinician (whether a trainer or a participant) should give a running commentary to the other participants throughout the procedure.
- If a participant performing a procedure wants the trainer to take over the procedure, he or she should make a straightforward request such as "I need help" or "Please, show me again how to do this".
- If a participant notices a complication that is unobserved by the operator, he or she has a responsibility to report the situation immediately to the trainer. This should be done in a way that does not alarm the client.
- If a complication arises during any procedure, the trainer is responsible for managing the situation, but may choose to permit a participant to manage the complication, as a learning experience, but only under supervision.
- If the trainer wants to take over the procedure from a participant, he or she will say something like "Let me help you with this step" or "Perhaps, I can show you an easier or better way to do this" or "The client is uncomfortable, so I'll finish the procedure. You can watch and do the next case".
- The participants who are observing the procedure should not interfere with the work of the participant conducting the procedure.
- The participants who are observing should hold all questions and comments until after the procedure is completed and until they are not in the presence of the client.
- The participant performing the procedure should answer the client's questions.
- If the client becomes impatient, angry, anxious, or restless during the procedure and if the participant is unable to reassure her, the trainer should take over the procedure.
- If a participant notices a problem or a break in sterile technique that was unobserved by the trainer, that participant is responsible for reporting the situation to the trainer immediately in a way that does not alarm the client.

## **E. Highlights of Client-Provider Interaction**

- When performing an IUD or implant insertion and removal procedures, it is important to remember the principles of effective client-provider interaction. Clients will be concerned about the procedure and the amount of pain they may feel. By using gentle techniques, providers can avoid giving women more pain.
- The provider can do several things to minimize the client's tension and maximize her comfort, which will contribute to the safe and efficient performance of the procedure.
- Some clients like to be informed of each step of the procedure, while others prefer to be distracted. Ask the client what will help her to relax.
- Inform the client that she might feel some discomfort. Request that she tells you if she feels any discomfort or pain.
- Before, during, and after the procedure, be aware of the client's need for privacy and her concerns about modesty.

## **F. Infection Prevention Reminders**

### *Before the procedure:*

- Insertion and removal of IUD or implants can be performed in an examination room or a special room. Wash hands thoroughly before putting on gloves and after each client.

### *During the procedure:*

- Use instruments, gloves, and drapes that have been sterilized or high-level disinfected. Maintain asepsis.

### *After the procedure:*

- While still wearing gloves, dispose of contaminated wastes (gauze, cotton, and other waste items) in a covered, leak-proof container or plastic bag.
- Ensure that instruments and reusable items are decontaminated in a 0.5% chlorine solution for 10 minutes immediately after use, while they are still in the procedure room.
- Ensure that the examination table, instrument stands, and other surfaces contaminated during the procedure are decontaminated by wiping with a cloth soaked in a 0.5% chlorine solution. If organic material remains after decontamination, wash with detergent and water. Decontamination and cleaning of the examination tables and couches between clients is important.
- Wash hands after removing gloves.

## G. Expectations from the participants during Clinical Observation

- They will all have the opportunity to observe procedures performed by the trainer and by other participants during the training programme.
- In addition to insertion and removal techniques, they will also observe, whenever possible, pre-procedure activities (such as client assessment) and post-procedure activities (such as giving instructions to the client). The goal is for them to have a comprehensive understanding of all the service-delivery steps.
- During observation of cases, participants should follow along with the IUD or Implant Clinical Skills Learning Guides.
- In addition to watching for the steps of insertion and or removal, they will also observe how the provider interacts with the client and what the provider does in terms of infection prevention practices. **Guidelines for supervised clinical practice**

Once their skills have been evaluated as satisfactory on the models, they may insert IUDs or implant under the trainer's supervision. The participants should not perform an insertion on a client until the trainer has evaluated their skills on the model using the appropriate IUD or Implant Clinical Skills Learning Guide.

The following tips may help a participant with clinical practice:

- Depending on his/her prior clinical experience, a participant may begin by observing an IUD or implant insertion, assisting the trainer in performing an insertion, or performing an insertion with the trainer's guidance.
- The participant must exercise patience. The participant should realise that s/he is learning a new technique, and it will take repetitive performance on the model and on clients before s/he feels comfortable with the technique.
- The participant should start with model practice and continue model practice during the early portion of his/her training to help fine-tune the skills and help him/her correct problems s/he is having in clinical practice.
- During clinical training, the trainer is present to provide the participant with support and guidance. S/He should ask questions and seek help if needed, being careful not to cause the client any extra concern.
- After each practice session, all participants will have time to review and discuss the cases with the trainers and other observers. The trainer will provide the participants with coaching as needed during this post-practice session.
- When the trainer determines that a participant is ready, the trainer will evaluate his/her performance using the appropriate IUD or Implant Clinical Skills Checklists.

## **H. Guidelines for the daily Post-practice sessions**

- At the post-practice meeting, the trainers will provide an opportunity for self-assessment in relation to the focus for the day.
- The participants may use the Learning Guide to assess their own performance.
- The trainers will use the post-practice meeting to give feedback to the entire group, and to jointly develop problem-solving approaches for skills difficulties.
- The following questions are useful for post-practice meeting to review the day's experience:
  - What went well?
  - What new learning needs did you have?
  - What new skill(s) did you learn?
  - What did not go well?
  - What do you think would have helped to make the procedures go better?
  - How could problems, which arose, have been avoided?
  - What was done to solve the problem?
  - How did the team members work together? How could they have worked more effectively?
  - Are there steps that you want to review before the next clinical practice session?

## **I. Guidelines for completing the “Clinical Procedures Record Sheet”**

- The participants' Clinical Service Record Sheet is to assist each participant to keep a track of all the procedures observed or performed during the training programme.
- These record sheets are not expected to replace the clinic Client Record Form that must be completed for each client by the participant.

## **Summary**

- This module provides the information and guidelines as to how the model and clinical practice sessions of this training programme will be conducted so that IUDs and Implants will be correctly inserted and/or removed safely.
- The ultimate goal is to provide high quality IUD and Implant services both during and after the training programme. The client's right to confidentiality must be protected. The priority concerns during clinical observation and practice are the client's comfort as well as safety and performing an effective procedure.

## **MODULE SEVEN**

### **COUNSELLING FOR IUDS AND IMPLANTS**

**Session 1:** Introduction to Counselling

**Session 2:** The Balanced Counselling Strategy

## **Module Seven - Session 1: Introduction to Counselling**

### **Learning Objectives:**

By the end of this session, participants should be able to:

- Define Counselling
- State the objectives of counselling in Family Planning
- Discuss the qualities of a successful counselor
- Mention the types of counselling required for IUD and Implant services
- Discuss the concerns and perceptions of potential users of IUDs and Implants
- Explain the term “Informed Choice”
- Discuss the “Rights of the Client”

### **Session Overview**

- Definition of Counselling
- Objectives of counselling in Family Planning
- Qualities of a successful counselor
- Types of counselling required for IUD and Implant services
- Concerns and perceptions of potential users of IUDs and Implants
- “Informed Choice”
- “Rights of the Client”

## **CONTENT**

### **A. Definition of Counselling**

- An interpersonal communication process in which the counselor helps the client to identify, clarify and resolve problems, makes informed decision and act on the decision.
- A process of communication/interaction between two or more people in which one person assists the other to identify, clarify, resolve problems and make informed decision on issue(s) of concern.
- Counselling refers to providing the client with information and support to allow her to make a decision regarding her immediate reproductive health needs, for example, by describing to the woman (and sometimes her partner as well) the contraceptive options available to her, the benefits and risks of the methods, and what side effects to expect.
- It is important for health care providers to be equipped with the necessary knowledge and skill to counsel clients for the uptake of family planning methods. Good counselling helps clients to choose and use family planning methods that suit them. Best counselling is tailored to meet the individual client's need.

### **B. Objectives of Counselling in Family Planning**

- To provide complete and accurate information in the language the client can understand;
- To identify and discuss any concerns or fears a client may have;
- To guide the client choose the best family planning method for her; and
- To inform the client adequately about effectiveness, side effects, benefits, and risks on available methods.

### **C. Qualities of a good Counselor**

- A Counselor has the following attributes:
  - A good counselor is empathetic (i.e. ability to understand other people's feelings) that earns the trust of the client;
  - A good understanding of all available family planning methods, not only IUDs and subdermal implants.
  - An understanding of the cultural and psychological factors that affect a woman's or a couple's decision to use IUD or subdermal implants or other family planning methods;
  - A non-judgmental approach-, not treating the client based on her/his values
  - Treating the client with respect and kindness
  - encourages clients to ask questions;
  - A good listener
  - The ability to recognize when he or she cannot sufficiently help a client and to refer the client to other professionals;
  - An appreciation of non-verbal communication- to understand body language able decode body language (body language).
- When counselling is done effectively, women will be more satisfied with their choices and less likely to discontinue use after a short period of time or because of unexpected bleeding disturbances.
- Sound knowledge and good communication skills are essential if the counselor is to discuss IUDs or subdermal implants (and other methods) appropriately and to reduce the number of women who discontinue the method because of ignorance or unnecessary anxiety.

### **D. Types of counselling required for IUD and Implant services**

CuT 380A and subdermal Implant users will need three stages of counselling as follows:

#### *Pre Insertion Counselling*

- This is given prior to a decision to use IUD and subdermal Implants
  - It involves a discussion of the woman's (or couple's) fertility intentions.
  - It provides information on all available contraceptive methods,
  - It presents an overview of Cu T 380A and subdermal Implants regarding:



- facts,
- reversibility,
- advantages and disadvantages including side-effects (particularly those related to menstrual irregularities),
- the timing of insertion,
- the contraceptive to use until insertion, and
- the freedom of the client to discontinue the method whenever desired.

### *Post-Insertion Counselling*

- Though, this is usually given immediately after the insertion of the IUD or Implant, some elements of post-insertion counselling should be given earlier and reinforced at this time (e.g. post-insertion care).
- It provides information on a follow-up schedule and indications for a quick return to the clinic.

### *Follow-up Counselling*

- Information given during post-insertion counselling should be reinforced at each visit.
- Counselors need to listen attentively and be prepared to answer questions on the problems the patient has encountered. Answering questions helps a client to cope with any problem or side effects.
- Again, counselors should reassure clients that removal is available on demand.

## **E. Myths, misconceptions and perceptions of users of IUDs and Implants**

- The device or capsule can travel in the body
- Belief that insertion/removal is a major surgical procedure
- Returning to the clinic (distance and time) for insertion and removal at proper time
- Inconvenience (time and cost) of follow-up visits
- With foreign object in the womb or the arm, soul cannot leave body after death
- Family/friends will notice and women will have the stigma of using family planning
- Religious/traditional/cultural reasons
- Never knowing when spotting will occur
- For Implants, sites can become unattractive
- No way to hide use of method from husband
- Rumours that women are being used as guinea pigs
- Chance of losing fertility, sex drive etc
- Fear that the device or capsules will cause weakness and/or ill health to self and/or husband
- Traditional dislike for surgical procedures
- Amenorrhoea causes a permanent build-up of blood in uterus that must be “drained” periodically, or illness will result (for subdermal implants).
- It makes a woman to become lean or develop a big stomach

## **F. Informed Choice**

“**Informed Choice**” means that:

- Clients have the clear, accurate, and specific information they need to make their own reproductive choices including a choice among family planning methods.
- Good quality: a good family planning service provider should explain each family planning method as needed, without information overload and can help clients use each method effectively and safely.
- A good family planning service provider should explain each family planning method as needed and should help clients use each methods, show the methods and allow clients touch and feel them.

“**Choice**” means that:

- Clients having a range of family planning methods to choose from. Good quality family planning services offer different methods to suit people's differing needs – not just 1 or 2 methods. If providers cannot provide a method or service, they should refer clients somewhere else for that method.
- Clients make their own decisions. Family planning providers help clients think through their decisions, but they do not pressure clients to make a certain choice or to use a certain method.

## **G. “Rights of the Client”**

The health provider must endeavour to respect the rights of the client seeking family planning and reproductive health services by providing them with relevant information concerning their reproductive health.

Such rights include:

- Information
- Access to services
- Informed Choice
- Safe services
- Privacy and Confidentiality
- Dignity, comfort and expression of opinion

## **Summary**

- Counselling provides a client with information that would help her make informed choice.
- A good counsellor is sensitive to the clients' needs and is ready to address user concerns regarding future reproductive goals, choice of contraceptive method and adverse effect of the chosen method.

## **Module Seven - Session 2: The Balanced Counselling Strategy Plus**

**Time:** 1 hour

### **Learning Objectives:**

By the end of this session, participants should be able to:

- Define the Balanced Counselling Strategy Plus
- State the objectives of the Balanced Counselling Strategy Plus
- Discuss the tools and job aids necessary for offering Balanced Counselling Strategy Plus
- Discuss the steps in the Balanced Strategy Plus
- Effectively counsel family planning clients using the steps, tools and job-aids in the Balanced Strategy Plus

### **Session Overview**

- Definition of the Balanced Counselling Strategy Plus
- Objectives of the Balanced Counselling Strategy Plus
- Tools and job aids necessary for offering Balanced Counselling Strategy Plus
- Steps in the Balanced Strategy Plus
- Demonstration of counselling family planning clients using the steps, tools and job-aids in the Balanced Strategy Plus

### **Methods**

- Illustrated lecture
- Discussion
- Demonstration and Return Demonstration
- Role Play

### **Materials**

- Flip chart and flip chart stand
- Markers
- LCD Projector
- Laptop
- Tools and Job Aids of BCS+

## **CONTENT**

### **What is Balanced Counselling Strategy (BCS)?**

The Balanced Counselling Strategy (BCS) is a practical, interactive, and client-friendly strategy for improving counselling within family planning consultations. This strategy, tested and refined in several countries, comprises a series of steps to determine the contraceptive method that best suits the client according to her/his preferences and needs. This strategy improves the quality of the provider's counselling and allows the client to take ownership of the decision.

The BCS uses three key job aids for counselling clients about family planning:

- An algorithm to guide the provider through the counselling process,
- A set of counselling cards for contraceptive methods, and
- Corresponding brochures for each method

## *The BCS Algorithm*

This summarizes the 19 steps recommended to implement the BCS during a family planning consultation. The steps are organized under four stages of the consultation: pre-choice needs assessment; method choice; post-choice actions; and STI/HIV prevention, risk assessment, and counselling and testing. During each stage of the consultation, the provider is given step-by-step guidance on how to use the BCS+ job aids. Depending on the client's response to the issues discussed, the algorithm outlines which action to take.

## *The Counselling Cards*

These are the cards that a provider uses during a counselling session. There are 19 counselling cards.

- The first card contains 6 questions that the service provider asks to rule out whether a client is pregnant.
- There are 14 method-specific cards that contain information about each family planning method. Each method card has an illustration of the contraceptive method on the front side of the card. The back of the card contains a list of 5 to 7 key features of the method and describes the method's effectiveness. These cards are used to first exclude those methods that are inappropriate for the client's reproductive intentions and then to narrow down the choice to reach a final decision.
- Four counselling cards provide information on STI/HIV transmission and prevention, risk assessment, dual protection, and HIV C&T and are used during the fourth stage of the consultation.

## **Method Brochures**

These brochures on each of the 14 contraceptive methods are designed to help the client better understand the method chosen. The provider gives the client the brochure of the selected method and a brochure with information on condoms to take home. Providers should encourage low-literate clients to take the brochure home so that their partner or other trusted friend can review the brochure with them again.

## **What is Balanced Counselling Strategy Plus (BCS+)?**

The Balanced Counselling Strategy Plus (BCS+) integrates counselling on STI/HIV transmission and prevention along with family planning by helping the provider to conduct an STI/HIV risk assessment, discuss dual protection, and discuss and offer the client opportunities for HIV C&T.

The BCS+ is divided into four counselling stages. Each stage contains a sequence of steps to follow. The BCS+ assumes that the motive of a client's visit is for family planning but serves to also offer the client STI/HIV services in the clinic or through referral. The BCS+ process can be summarized as a decision-making algorithm. The summary of the four counselling stages is:

### **Pre-Choice Stage**

- During this stage, the provider creates the conditions that help a client select a family planning method. The provider:
  - Cordially greets the client.
  - Emphasizes to the client that, during the consultation, other reproductive health issues such as STIs, including HIV, will be addressed depending on her/his individual circumstance.

- Rules out pregnancy using the counselling card with the checklist of questions
- If the client is not pregnant, displays all the method cards and asks the four questions described in the algorithm.
- Sets aside the cards of the methods that are not appropriate for the client as the client responds to each question (setting aside these cards helps to avoid giving information on methods that are not relevant to the client's needs).
- If pregnancy cannot be ruled out, the provider skips to steps 12 to 19 to discuss STI/HIV transmission and prevention, risk assessment, dual protection and HIV C&T. Then the client is given a back-up method, such as condoms, and asked to return when she has her menstruation.

### Method Choice Stage

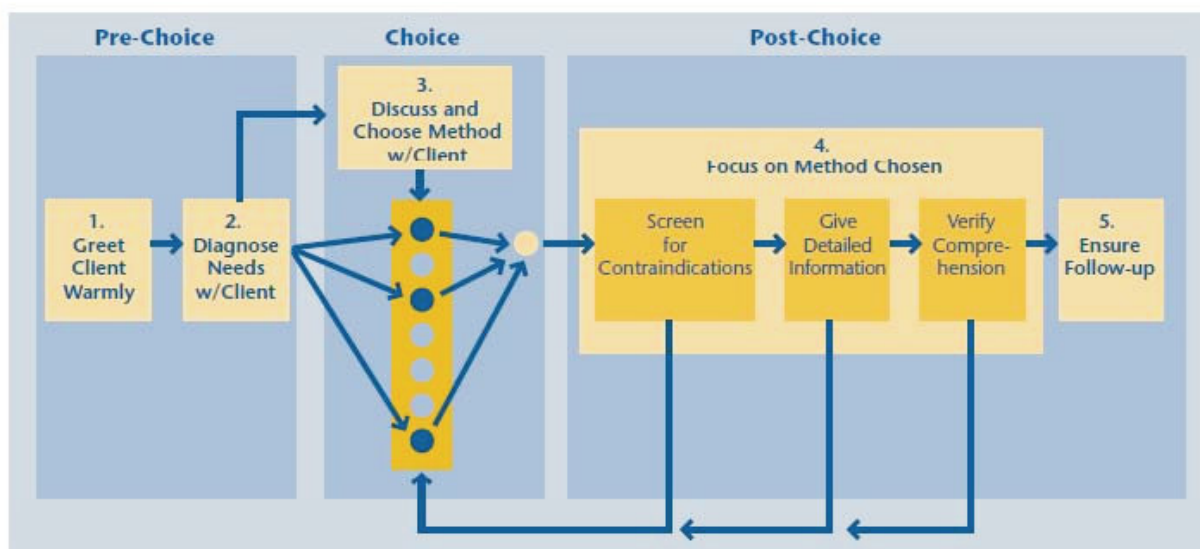
During this stage, the provider offers more extensive information about the methods that have not been set aside, including their effectiveness. This helps the client select a method suited to his/her reproductive needs. Following the steps in the BCS+ algorithm, the provider continues to narrow down the number of counselling method cards until a method is chosen.

### Post-Choice Stage

During this stage, the provider uses the method brochure to give the client complete information about the method that has been chosen. If the client has conditions where the method is not advised or is not satisfied with the method, the provider returns to the Method Choice Stage to help the client select another method. The provider also encourages the client to involve their partner(s) in decisions about contraception, either through discussion or visit to the clinic.

### STI/HIV Prevention, Risk Assessment, and Counselling and Testing Stage

During this stage, the provider uses the four counselling cards to discuss STI/HIV transmission and prevention, conduct a risk assessment, define dual protection, and discuss and offer the client opportunities for HIV C&T. If the client is willing to be tested, the provider encourages the client to disclose their STI/HIV status to their partner(s), and lets the client know both the benefits and risks of disclosure. The provider gives follow-up instructions, the method brochure and condom brochure, emphasizing dual protection.



Source: León et al. 2003b.

## Algorithm for Using the Balanced Counselling Strategy

<b>Pre-Choice Stage</b>	<ol style="list-style-type: none"> <li>① Establish and maintain a warm, cordial relationship. Listen to the client's contraceptive needs.</li> <li>② Rule out pregnancy using the pregnancy checklist card with 6 questions.           <table border="1" style="width: 100%; border-collapse: collapse; margin-top: 5px;"> <thead> <tr> <th style="text-align: left; padding: 2px;">If client answers:</th> <th style="text-align: left; padding: 2px;">Then:</th> </tr> </thead> <tbody> <tr> <td style="padding: 2px;">"Yes" to any of the questions and she is free of signs and symptoms of pregnancy</td> <td style="padding: 2px;">1) Pregnancy is unlikely. 2) Continue to <b>Step 3</b>.</td> </tr> <tr> <td style="padding: 2px;">"No" to all of the questions</td> <td style="padding: 2px;">1) Pregnancy cannot be ruled out. 2) Give client a pregnancy test, if available, or refer her to an antenatal clinic. 3) Ask her to return when she has her menstrual bleeding. 4) Provide her with a back-up method, such as condoms, to use until then. 5) Go to <b>Steps 12 to 19</b>.</td> </tr> </tbody> </table> </li> <li>③ Display all of the method cards. Determine whether the client wants a particular method.</li> <li>④ Ask <b>all</b> of the following questions. Set aside method cards based on the client's responses.           <ol style="list-style-type: none"> <li>a) Do you wish to have children in the future? If "Yes," set aside vasectomy and tubal ligation cards. Explain why. If "No," keep all cards and continue.</li> <li>b) Are you breastfeeding an infant less than 6 months old? If "Yes," set aside the combined oral contraceptives (the Pill) and combined injectable contraceptive (CIC) cards. Explain why. If "No," or she has begun her monthly bleeding again, set aside the lactational amenorrhea method (LAM) card. Explain why.</li> <li>c) Does your partner support you in family planning? If "Yes," continue with the next question. If "No," set aside the following cards: Standard Days Method<sup>®</sup> and Two Day Method<sup>®</sup>. Explain why.</li> <li>d) Are there any methods that you do not want to use or have not tolerated in the past? If "Yes," set aside the cards the client does not want. If "No," keep the rest of the cards.</li> </ol> </li> </ol>	If client answers:	Then:	"Yes" to any of the questions and she is free of signs and symptoms of pregnancy	1) Pregnancy is unlikely. 2) Continue to <b>Step 3</b> .	"No" to all of the questions	1) Pregnancy cannot be ruled out. 2) Give client a pregnancy test, if available, or refer her to an antenatal clinic. 3) Ask her to return when she has her menstrual bleeding. 4) Provide her with a back-up method, such as condoms, to use until then. 5) Go to <b>Steps 12 to 19</b> .
If client answers:	Then:						
"Yes" to any of the questions and she is free of signs and symptoms of pregnancy	1) Pregnancy is unlikely. 2) Continue to <b>Step 3</b> .						
"No" to all of the questions	1) Pregnancy cannot be ruled out. 2) Give client a pregnancy test, if available, or refer her to an antenatal clinic. 3) Ask her to return when she has her menstrual bleeding. 4) Provide her with a back-up method, such as condoms, to use until then. 5) Go to <b>Steps 12 to 19</b> .						
<b>Method Choice Stage</b>	<ol style="list-style-type: none"> <li>⑤ Give information on the methods that have <b>not</b> been set aside and indicate their effectiveness.           <ol style="list-style-type: none"> <li>a) Arrange the remaining cards in order of effectiveness (number on back of each card).</li> <li>b) In order of effectiveness (lowest number to highest, read the 5 to 7 attributes on each method card not set aside. Ensure that client fully understands the information given on the method before proceeding to the next card.</li> </ol> </li> <li>⑥ Ask the client to choose the method that is most convenient for her/him.</li> <li>⑦ Using the method-specific brochure, determine whether the client has any conditions for which the method is not advised.           <ol style="list-style-type: none"> <li>a) Together with the client review the section under "Method not advised if you..." in the brochure of the method chosen.</li> <li>b) If the methods not advisable for the client, ask the client to select another method from the cards that remain. Repeat the process from <b>Step 6</b> (<b>Step 4</b> if the client already had a method in mind).</li> </ol> </li> </ol>						
<b>Post-Choice Stage</b>	<ol style="list-style-type: none"> <li>⑧ Discuss the method chosen with the client using the method brochures as a counseling tool.</li> <li>⑨ Determine the client's comprehension and reinforce key information.</li> <li>⑩ Make sure the client has made a definite decision. Give her/him the method chosen and/or a referral and back-up method, depending on the method selected.</li> <li>⑪ Encourage the client to involve partner(s) in decisions about/practice of contraception through discussion or visit to the clinic.</li> </ol>						
<b>STI/HIV Prevention, Risk Assessment, and Counseling and Testing Stage</b>	<ol style="list-style-type: none"> <li>⑫ Discuss STI/HIV transmission and prevention and the client's HIV status using the counseling card.</li> <li>⑬ Conduct STI/HIV risk assessment using the counseling card. If the client has STI symptoms treat her/him syndromically.</li> <li>⑭ Discuss dual protection using the counseling card. Offer condoms and instruct client in correct and consistent use.</li> <li>⑮ Conduct HIV counseling and testing (C&amp;T) awareness using the counseling card. If the client is known to be HIV positive, skip to step 17.</li> <li>⑯ Discuss and offer the client an opportunity for HIV C&amp;T. If willing, test the client and counsel her/him on the test results according to national protocols.</li> <li>⑰ Encourage the client to disclose HIV status to her/his partner(s). Let the client know the benefits and risks of disclosure.</li> <li>⑱ Give follow-up instructions, a condom brochure and the brochure of the method chosen.</li> <li>⑲ Complete the counseling session. Invite the client to return at any time. Thank her/him for the visit. End the session.</li> </ol>						

## Steps of the Balanced Counselling Strategy Plus Pre-Choice Stage

During this stage, the provider creates the necessary conditions to help the client select a method.

### ***Step 1. Establish and maintain a warm, cordial relationship. Listen to the client's contraceptive needs.***

- Establish a formal but friendly manner
- Call the client by her/his name
- Demonstrate interest in what the client tells you
- Establish eye contact with the client
- Listen to and answer her/his questions
- Show support and understanding without judgment
- Ask questions to encourage participation in the discussion
- Ask whether the client would like a family planning method. If so rule out pregnancy as described in Step 2.

### ***Step 2. Rule out pregnancy using the pregnancy using the pregnancy checklist card with 6 questions.***

Pregnancy is a contraindication to the use of most family planning methods, except barrier methods such as condoms. It is important to rule out the possibility of the client being pregnant, which can be done by asking the 6 questions on the pregnancy checklist card.

*Checklist to be reasonably sure a woman is not pregnant:*

- Did you have a baby less than six months ago? If so are you fully or nearly fully breastfeeding? Have you had no monthly menstrual bleeding since giving birth?
- Have you abstained from unprotected sex since your last menstrual bleeding or delivery?
- Have you given birth during the last four weeks?
- Did your last menstrual bleeding start within the past 7 days (or 12 days if you plan to use an intrauterine device (IUD))?
- Have you had a miscarriage or abortion in the last 7 days?
- Have you been using a reliable contraceptive method consistently and correctly?

*Rule out pregnancy using the table below:*

#### **If the client answers:**

“Yes” to any of the questions and is free of symptoms and signs of pregnancy

“No” to all of the questions

#### **Then:**

- 1) Pregnancy is unlikely
- 2) Continue to **Step 3**

1. Pregnancy cannot be ruled out
2. Give the client a pregnancy test, if available, or refer her to the antenatal clinic.
3. Ask her to return when she has her next menstrual bleeding
4. Provide her with a back-up method, such as condom to use until then
5. Go to **Steps 12 to 19**

**Step 3. Display all of the method cards. Determine whether the client wants a particular method.**

1. Display all the BCS method cards on a desk or table, grouped by method type (temporary, fertility awareness, permanent).
2. Each card has information about a different family planning method.
3. Ask whether the client has a particular method in mind.

**If the client:**

Says "No"  
Says "Yes"

**Do this:**

Continue to **Step 4**.

1) Ask what the client knows about the method.

2) If the information is correct, go to **Step 7**.

? Gives incomplete information about the method s/he has chosen

1) Correct any misinformation.

2) If necessary, go to **Step 4** to help the client choose a method.

**-Or-**

? Does not know other alternatives that might be more convenient

**Step 4. Ask all of the following questions. Set aside cards based on the client's responses.**

1. Using the display of method cards, begin the process by saying something like, "Now we are going to discuss your contraceptive needs. We will narrow down the number of methods that might be best for you. Then I will discuss the features of each method with you. This will help us to find the right method for your needs."

Ask the 4 questions below. Based on the client's responses, set aside the cards of methods that do not suit her/his needs.

**If:**

"Yes"

**Do this:**

1) Set aside the vasectomy and tubal ligation cards.

Explain that sterilization is permanent and not suitable for someone who thinks s/he might want to have another child.

"No"

Keep all cards and continue.

**b) Are you breastfeeding an infant less than 6 months old?**

**If:**

"Yes"

**Do this:**

1) Set aside the combined oral contraceptive (the Pill) and combined injectable contraceptive (CIC) cards.

2) Explain that the hormones in these methods affect breastfeeding.

"No"

1) Set aside Lactational

Amenorrhoea Method (LAM) card.

2) Explain that LAM is not suitable for women who are having menstrual bleeding again.



**c) Does your partner support you in family planning?**

**If:**

“Yes”

“No”

**Do this:**

Continue with the next question.

1) Set aside the following cards:  
Standard Day’s Method and Two  
Days’ Method

2) Explain that these require partner  
cooperation.

3) Invite the client to bring her/his  
partner to a counselling session to  
discuss family planning with a  
provider.

4) Point out that male and female  
condoms also require partner  
cooperation but they are important  
for protecting against STIs, including  
HIV

5) Continue with the next question.

**d) Are there any methods that you do not want to use or have not tolerated in the past?**

**If:**

“Yes”

**Do this:**

1) Ask which methods s/he used and  
her/his experience with each.

2) Set aside the cards of the methods  
the client **does not** want.

“No”

Keep the rest of the cards.

The client has eliminated a method  
because of rumours or false  
information.

1) Provide the correct information.  
2) Do not set aside the card of that  
method.

3. If certain methods, such as the IUD, implants, tubal ligation, or vasectomy, are not offered at your health care facility, still talk to the client about these methods.

### **Method Choice Stage**

#### **Step 5: Give information on the methods that have not been set aside and indicate their effectiveness.**

1. Arrange the remaining method cards that have been set aside on your desk or table according to their level or effectiveness.
2. Display them with the lowest numbers first and the highest numbers last. (*The number is on the bottom left-hand side of the back of the card. This number indicates the effectiveness of the method.*)
3. Explain the effectiveness of the methods. Effectiveness is measured in number of pregnancies among 100 women in the first year of use. The lower number means fewer women get pregnant using the method.

4. Begin with the card with the lowest number. Read the 5 to 7 key features of each method on the cards displayed. You may also ask the client to read these attributes her/himself.
5. Explain that the condom (male and female) is the only method that provides dual protection against pregnancy and STIs, including HIV. Emphasize the following:
  - a) Male and female condoms significantly reduce the risk of infection with STIs, including HIV, when used correctly and consistently with every act of sex.
  - b) When used consistently and correctly, condom use prevents 80 percent to 95 percent of HIV transmission that would have occurred without condoms.
  - c) Condoms reduce the risk of becoming infected with many STIs when used consistently and correctly:
    - Protect best against the spread of STIs by discharge, such as HIV, gonorrhea, and Chlamydia.
    - Also protect against spread of STIs from skin-to-skin contact, such as herpes and human papilloma virus.

**Step 6. Ask the client to choose the method that is most convenient for her/him.**

1. Ask the client whether s/he has questions or comments about each method discussed. Respond to any questions. Resolve any doubts before proceeding.
2. Ask the client to choose a method that is most convenient for her/him.
3. If the client asks that you choose the method, explain that s/he is the only person who knows her/his needs. You may give recommendations about a method, but allow the client to make the final choice.
4. Once the client selects a method, **do not** take the remaining cards off the table. You may need to return to them if the method chosen is not advised or the client changes her/his mind.
5. If the client does not like any of the methods discussed or cannot make up her/his mind, give the client a back-up method, such as condoms, to use until s/he decides on a method of choice. Condoms can provide dual protection against pregnancy and STIs until the client has another or additional method. Go to Step 12.

**Step 7. Using the method-specific brochure, determine whether the client has any conditions for which the method is not advised.**

1. Select the BCS+ method-specific brochure corresponding to the method chosen by the client.
2. Together with the client, review the section entitled, "Method not advised if you..." in the method brochure. This lists conditions under which the method is not advised.

**For example.** For IUD:

Method NOT advised if you:

Are pregnant or think you might be pregnant.

Have unusual vaginal bleeding.

Have any genital or pelvic infections.

Have AIDS and are NOT taking antiretroviral (ARV) medicine or are not well clinically.

Have an STI or are at very high risk of having an STI.

3. Using simple and clear language, ask probing questions to make sure that the client **does not** have any conditions for which the method is not advised.
4. Based on the client's response, decide whether to provide the method or return to a previous step.

**If the client:**

Has no conditions

Has any condition

**Do this:**

Go to Step 8

1) Explain the need to choose another method.

2) Return to **Step 5**

Has any condition and reached this step from Step 3 (already had the method in mind)

1) Explain the need to choose another method.

2) Return to **Step 4.**

## **Post-Choice Stage**

### **Step 8. Discuss the method chosen with the client using the method brochure as a counselling tool.**

1. Use the method brochure as a counselling tool to review all the information about the method chosen by the client. Begin by saying something like, "Mrs./Mr. (name), this brochure is for you to take home. Before you go, I would like to review the information with you."
2. Using clear, simple language, review the information about the method presented in the brochure:
  - General information (This is the same information as on each BCS+ method card).
  - How the method works
  - Important facts about the method
  - When the method is not advised
  - Side effects
  - Health benefits
  - How to use
  - Follow-up (if applicable)
  - When to return to the health care facility
3. Give the client the brochure. Encourage her/him to review the brochure again at home and when s/he needs to remember anything about the method.
4. If the client selects a method not available on site, then:
  - a) Still give client the brochure of the method chosen.
  - b) Refer the client to a facility or commercial outlet where s/he can obtain the method.
  - c) Provide the client with an alternative, suitable method until s/he can obtain the choice.

5. If the client selects a method that is temporarily unavailable (out of stock), then:
  - a) Give the client a brochure of the method chosen.
  - b) Refer the client to a facility or commercial outlet where s/he can obtain the method.
  - c) Provide the client with a back-up method until s/he can obtain the method of choice.
  - d) Ask the client to return when the method is in stock at your health care facility.

**Step 9. Determine the client's comprehension and reinforce key information.**

1. Make sure the client fully understands all aspects of the method s/he has chosen. Comprehension is key to a healthy, effective use of the method.
2. Validate comprehension by asking the client to answer the following questions in her/his own words. (S/he may refer to the brochure.)

How do you use the method you have chosen?

- What side effects might you experience with the method?
  - Can the method protect you against getting an STI, including HIV?
  - What are the signs indicating when you should return to the health care facility?
3. Assure the client that is s/he cannot remember all the details. Make sure the client can find the information in the brochure. (Note: If the client cannot read or has very low literacy skills, ask the client to identify a person at home who can read the information on the method chosen.)
  4. Ask whether the client has any questions. Reinforce the basic information on the method chosen.

**Step 10. Make sure the client has made a definite decision: Give her/him the method chosen and/or a referral and back-up method, depending on the method selected.**

1. Ask the client whether her/his choice is a definite one. Make sure s/he is happy with the choice of method.

**If the client is:**

Happy with the method chosen

**Do this:**

- 1) Give her/him the method and brochure
- 2) If IUD, implant, tubal ligation, or vasectomy is chosen and not available on site, give a referral for the procedure.
- 3) If the client cannot immediately use the chosen method, provide a back -up method (e.g., condoms). Give the BCS+ brochure on condoms.
- 4) Suggest that s/he may also abstain from sex until s/he obtains the method of choice.

Not happy with the method chosen and wishes to consider other options.

- 1) Assure the client that it is fine to change her/his mind. The client has a right to informed choice.
- 2) Return to **Step 5**.

2. Do not let the client leave empty-handed. If a method is not available, make sure that the client has a back-up method (e.g., condoms), a referral, and the BCS+ brochure on condoms.
3. Give the client his/her brochure.

**Step 11. Encourage the client to involve partner(s) in decisions about/practice of contraception through discussion or a visit to the clinic.**

1. Encourage the client to discuss her/his contraceptive method with their partner.
2. Mention that this can help them in the following manner:
  - Partner can remind you of the time to take your method, if taking a method regularly, and follow-up dates.
  - You can negotiate condom use to prevent STI, including HIV
  - You can discuss your plans to have children, whether you are HIV positive or negative.
  - You can let him know that the prevention of mother-to-child transmission (PMTCT) of HIV during pregnancy can reduce transmission to babies.
  - He/she can support you if you need wellness and HIV services (antiretroviral therapy [ART])

**STI/HIV Prevention, Risk Assessment, and Counselling and Testing Stage.**

Use the four counselling cards to discuss STI/HIV transmission and prevention, risk assessment, dual protection, and HIV C&T. During the discussion, emphasize that prevention, early detection, and prompt management of STIs, including HIV, are beneficial to the client, her/his partner and family, and the community at large.

*For further details on this section, please see: Raney Laura., Saiqa Mullick., Wilson Liambila., Mantshi Menziwa., Doctor Khoza., and Ian Askew . (2008). *Balanced Counselling Strategy Plus User's Guide*, part of *The Balanced Counselling Strategy Plus: A Toolkit for Family Planning Service Providers Working in High STI/HIV Prevalence Settings*. Mullick et al., Washinton DC: Population Council. **OR***

*“The Balanced Counselling Strategy Plus: A Toolkit for Family Planning Service Providers” published by USAID Strengthening Private Sector Family Planning/RH Services Project, Lagos, Nigeria.*

**SUMMARY**

The Balanced Counselling Strategy Plus (BCS+) is a practical, interactive, and client-friendly tool for improving counselling within family planning consultations. The strategy improves the quality of the provider's counselling and allows the client to take ownership of the decision. The BCS has proved to be an effective tool that assists family planning providers to improve the quality of their care. The approach is practical, low cost, and easy to adapt to local contexts.

**EVALUATION**

- Mention the job aids of the BCS+
- List the four counselling stages of the BCS+
- Why is important to give the BCS+ Method Brochure to the client to take home?

## **MODULE EIGHT**

### **INFECTION PREVENTION PRACTICES DURING IUD AND IMPLANT INSERTION AND REMOVAL TECHNIQUES**

**Session 1:** Asepsis, Hand washing and gloving

**Session 2:** Disinfection and Sterilization

**Session 3:** Disposal of Sharps and Waste

## **Module Eight - Session 1: Asepsis, Hand Washing and gloving**

### **Learning Objectives:**

By the end of this session, participants should be able to:

- Discuss importance of Infection Prevention and the Disease Transmission Cycle
- Identify potential consequences of poor Infection Prevention practices
- Define Infection Prevention Terms
- Define the Aseptic technique
- Explain the importance of hand washing in Infection Prevention
- Demonstrate the steps of surgical hand scrub
- Demonstrate the gloving process
- Describe ways to properly prepare a client for clinical procedures
- Describe the steps of establishing and maintaining a sterile field

### **Session Overview**

- Importance of Infection Prevention and the Disease Transmission Cycle
- Potential consequences of poor Infection Prevention practices
- Definition of Infection Prevention terms
- Definition of the Aseptic technique
- Importance of Hand washing in Infection Prevention
- Steps of surgical hand scrub
- The Gloving process
- Preparing a client for clinical procedures
- Steps for establishing and maintaining a sterile field

## **CONTENT**

### **A. Importance of Infection Prevention and the Disease Transmission Cycle**

- Proper infection prevention practices must be followed in order to minimize the risk of infection and serious disease for the client, the provider, and all facility staff members.
- People with infections, both clients and staff member, may not have any sign or symptoms of the infections they carry.
- This is particularly notable for HIV and hepatitis viruses, but is the case for other infections as well.
- Therefore, it is important for all staff to practice proper infection prevention with all clients at all times.
- All health providers are responsible for client and staff safety. This includes ensuring that appropriate infection prevention practices are followed at the facilities.

## B. Potential consequences of poor Infection Prevention practices

- Potential consequences of poor Infection Prevention practices are:
  - Infection, such as HIV, hepatitis and others commonly found in clinic settings (e.g. *Staphylococcus* and *Streptococcus*) may be transmitted to clients, providers or clinic staff.
  - Many infections related to service use are consequences of inappropriate IPPS procedure used during the service provision.
  - A provider-caused (iatrogenic) reproductive tract infection, such as endometritis or pelvic inflammatory disease (PID), may result from poor infection prevention practices.
  - A client who acquires a post-procedure infection as a result of using a family planning method may never want to use the method again.

## C. Definition of Infection Prevention terms

- *Microorganisms* are the causative agents of infection. They include bacteria, viruses, fungi and parasites. For infection prevention purposes, bacteria can be further divided into three categories: vegetative (*staphylococcus*), mycobacteria (tuberculosis) and endospores (tetanus). Spores are the most difficult to kill.
- The terms asepsis, antisepsis, decontamination, cleaning, disinfection and sterilization often are confusing. For the purpose of this manual, the following definitions will be used:
  - *Asepsis and Aseptic Technique* are general terms used to describe the combination of efforts made to prevent entry of microorganisms into any area of the body where they are likely to cause infection. The goal of asepsis is to reduce to a safe level, or eliminate, the number of microorganism on both animate (living) surfaces such as skin and tissue, and inanimate objects such as surgical instruments and other items.
  - *Antisepsis* is the prevention of infection by killing or inhibiting the growth of microorganisms on skin and other body tissues using a chemical agent (antiseptic).
  - *Decontamination* is the process that makes objects safer to be handled by staff before cleaning (It reduces the number of, but does not eliminate, microorganisms on instruments and other items). Objects to be decontaminated include large surfaces (e.g. capsules or operating tables) and surgical instruments, gloves and other items contaminated with blood or body fluids.
  - *Cleaning* is the process that physically removes all visible blood, body fluids or any other foreign material such as dust or dirt from skin or inanimate objects.
  - *Disinfection* is the process that eliminates most, but not all, disease-causing microorganisms from inanimate objects.
  - *High-Level Disinfection (HLD)* by boiling, steaming or the use of chemicals eliminates all microorganisms except some bacterial endospores from inanimate objects.
  - *Sterilization* is the process that eliminates all microorganisms (bacteria, viruses, fungi and parasites) including bacteria endospores from inanimate objects.



#### **D. Define the Aseptic technique**

- *Asepsis and Aseptic Technique* are general terms used to describe the combination of efforts made to prevent entry of microorganisms into any area of the body where they are likely to cause infection.
- The goal of asepsis is to reduce to a safe level, or eliminate, the number of microorganisms on both animate (living) surfaces such as skin and tissue, and inanimate objects such as surgical instruments and other items.
- Aseptic techniques are routine practices before, during and after clinical procedures.
- Placing a physical, mechanical or chemical “barrier” between microorganisms and an individual, whether a client or health worker, is an effective means of preventing the spread of disease (i.e., the barrier serves to break the disease transmission cycle).
- The following aseptic techniques refer to infection prevention practices that create protective barriers for infection prevention:

#### **E. Hand washing;**

- Wearing gloves (both hand) either for surgery or when handling contaminated waste materials or soiled instruments;
- Wearing appropriate attire (e.g. protective goggles, face mask or apron) when in contact with blood or body fluids is possible;
- Using antiseptic solutions to prepare the skin prior to clinical procedures.
- Using safe work practices such as **not** recapping or bending needles, safely handling surgical instruments, and properly disposing of waste materials; and
- Maintaining a safer environment in the procedure area

#### **F. Importance of Hand washing in Infection Prevention**

- Hand washing may be the single most important procedure for preventing infection.
- It is indicated:
  - when examining a client (before and after each client)
  - when putting on sterile gloves for surgical procedure
  - after any situation that may make hands to become contaminated
  - after removing gloves

#### *Types of hand washing:*

- *Types and steps of hand washing as follows:*
  - Plain soap with running water – routine
  - Antiseptic with running water
  - Alcohol scrubs

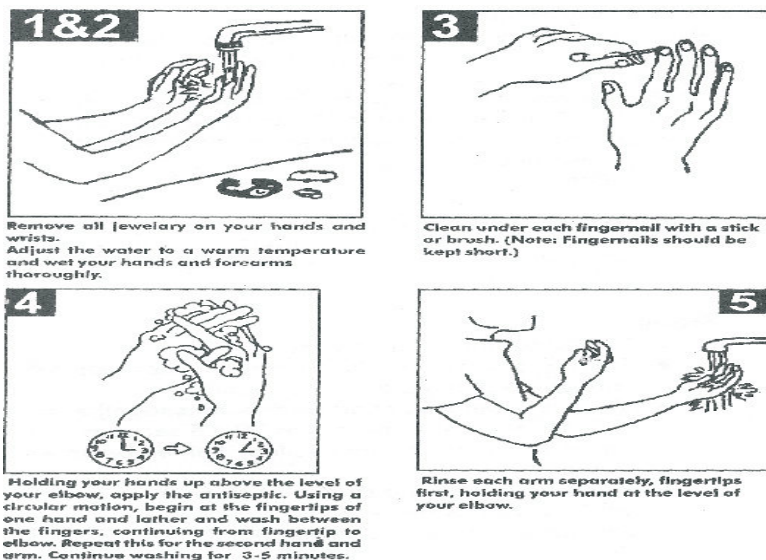
Steps of hand washing:

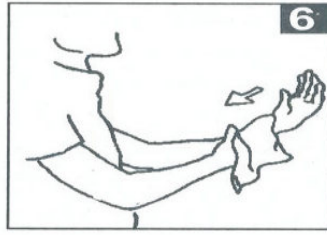


- Wet the hands with running water
  - Rub both hands together with soap and lather, making sure to rub all parts of your hands
  - Vigorously weave fingers and thumbs together and slide them back and forth for 10–15 seconds or for longer if hands are visibly soiled
  - Remember to wash around the nails
  - Rinse hands under a stream of clean, running water until all soap is gone
  - Dry hands with a clean towel or allow hands to air-dry
- Hands should be washed first on arrival at work, in-between attending to clients, and as the last thing when leaving the health facility.

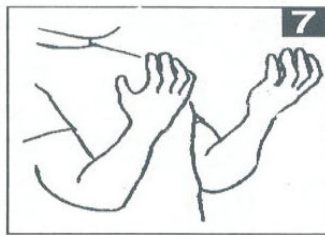
**G. Steps of hand washing**

**Figure 8.1.1 - Steps in performing a surgical hand scrub**





Using a sterile towel, wipe your arm- from fingertips to elbow- dry. Use one side of the towel to dry the first hand and the other side of the towel to dry the second hand.



Keep your hands above the level of your elbow and do not touch anything

### Steps of Surgical hand scrub

- Remove all jewellery
- Wet hands and forearms thoroughly
- Clean fingernails with a brush
- Hold your hands up above the level of your elbows
- Apply antiseptic
- Using a circular motion, begin at the fingertips of one hand, lather and wash between fingers, continuing from finger tips to elbows
- Repeat for the second hand and arm for 3–5 minutes
- Rinse each arm separately, finger tips first, holding your hand above the level of your elbow
- Using a sterile towel, wipe your arms dry from finger tips to elbow
- Use one side of the towel to dry the first hand and the other side to dry the second hand
- Keep your hands above the level of your elbows and do not touch anything

*Procedures to follow in cleaning hands when running water is not available:*

- A bucket with a tap that can be turned off to lather hands and turned on again for rinsing
- A bucket and pitcher, with one person pouring the water over the other's hands and allowing it to drain into the bucket
- An alcohol hand rub, which does not require water

### Steps of Alcohol Hand rub

- Apply 3-5 ml of alcohol or an alcohol hand rub solution
- Rub hands together until they are dry
- Because using alcohol alone tends to dry the skin, it is best to use an alcohol handrub solution.

*To prepare an alcohol handrub solution, add together:*

- 2 ml of glycerine, propylene glycol, or sorbitol and
- 100 ml of 60-90% alcohol

**Note:** An alcohol handrub does not remove soil or organic material such as blood. Therefore, an alcohol handrub should not be used when hands are visibly soiled.

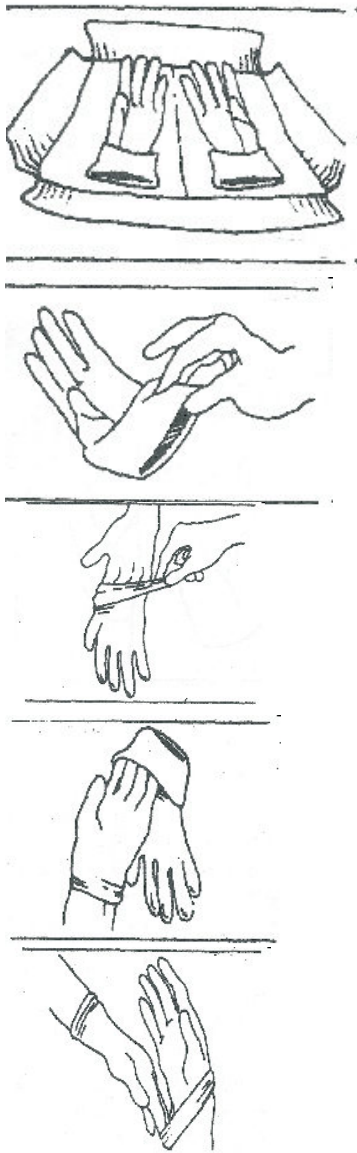
### A. The Gloving process

*When to wear gloves:*

- When in contact with blood and body fluids from any client
- When performing a procedure
- When disposing of contaminated waste items (cotton, gauze or dressings)

**Note:** A separate pair of gloves must be used for each client to avoid cross-contamination

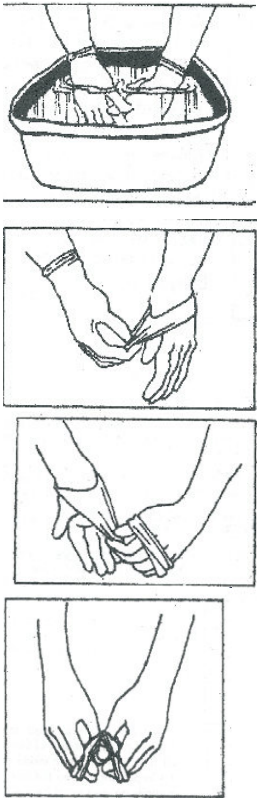
**Figure 8.1.2: Steps for putting on sterile or high-level disinfected surgical gloves**



1. Prepare a large, clean, dry area for opening the package of gloves. (If the gloves have been processed and are not wrapped in a package, lay them on a sterile or high-level disinfected surface). Either (1) open the outer glove package and then perform a surgical hand scrub, or (2) perform a surgical hand scrub and then ask someone to open the package for you. Dry your hands completely.
2. Open the inner glove wrapper, exposing the cuffed gloves with the palms up.
3. Pick up the glove by the cuff, touching only the inside portion of the cuff (the side that will be touching your skin when the glove is on).
4. While holding the cuff, slip your other hand into the glove. (Pointing the fingers of the glove toward the floor will keep the fingers open). Be careful not to touch anything, and hold the gloves above waist level. (Note: if the first glove is not fitted correctly, wait to make any adjustment until the second glove is on. Then use the sterile or high-level disinfected fingers of one glove to adjust the sterile or high-level disinfected portion of the other glove).
5. Pick up the second glove by sliding the fingers of the gloved hand under the cuff of the second glove. Be careful not to contaminate the gloved hand with the ungloved hand as the second glove is being put on.
6. Put the second glove on the ungloved hand by maintaining a steady pull through the cuff.
7. Adjust the position of the gloved fingers until the gloves fit comfortably.

Adapted from: Intrah, 1996. Infection Prevention in FP/MCH Clinics. In: Guidelines for Clinical Procedures in Family Planning: A Reference for Trainers. Chapel Hill, NC, pp. A11-22, A11-23.

**Figure 8.1.3: Steps for removing surgical gloves**



1. Rinse gloved hands in a basin of decontaminated solution to remove blood or other body fluids.
2. Grasp one of the gloves near the cuff and pull it part of the way off. Turn the glove partially on your hand before removing the second glove to protect you from touching the outside surface of either glove with your bare hands.
3. Leaving the first glove over your fingers, grasp the second glove near the cuff and pull it part of the way off. The glove will run inside out. It is important to keep the second glove partially on your hand to protect you from touching the outside surface of the first glove with your bare hand.
4. Pull off the two gloves at the same time, being careful to touch only the inside surfaces of the gloves with your bare hands.
5. If the gloves are disposable or are not intact, dispose of them properly (as stated under information on managing medical waste at the end of this chapter). Wash your hands immediately after removing the gloves, since the gloves may contain invisible holes or tears, leaving you at risk of exposure to contaminated blood and other body fluids.

#### **I. Preparing a client for clinical procedures**

- Client preparation before a clinical procedure involves using an antiseptic solution on the client's skin, vagina, or cervix to destroy or prevent the growth of microorganisms.
- Most surgical-site infections result from contamination during surgery – not, as many people believe, because clients do not keep the wound clean after surgery. Frequently, bacteria from the client's skin or tissues is the cause of infections.
- Thus, it is critical to pay strict attention to proper preparation of the client before a procedure.

#### **J. Steps for establishing and maintaining a sterile field**

##### *Steps for establishing a sterile field*

- Place only sterile items within the sterile field;
- Open, dispense, and transfer sterile items without contaminating them;
- Consider items located below the level of draped painted as unsterile;
- Do not allow *scrubbed personnel* to reach across unsterile areas or touch unsterile items;
- Do not allow *unscrubbed personnel* to reach across sterile field or touch sterile items;

- Recognize and maintain sterile field;
- Recognize that the edges of a package containing sterile items are unsterile;
- *Recognize that a sterile barrier that has been penetrated is considered contaminated.*
- Be conscious of where you are at all times and move within or around the sterile field.
- Do not place sterile items near open windows or doors.

#### *Steps for maintaining a safer environment*

- Limit entry of unauthorized individuals to surgical/procedure areas;
- Close doors and draw curtains during all procedures;
- Ensure that all personnel in the surgical area wear clean clothes, masks, caps and good footwear;
- Enclose the surgical procedure area to minimize dust and eliminate insects; air-condition the room;
- Decontaminate and clean examination/operating tables, counters, instrument trolleys, etc., before a new client is brought into the room;
- Remove used gloves before touching anything. Countertops, faucets, and pens and pencils are frequently contaminated because health care workers touch them while wearing used gloves.
- Processing gloves for reuse is **not** recommended, since gloves are difficult to properly process. Processing and reusing disposable gloves is especially not recommended.
- Studies have shown that invisible holes or tears are likely to occur when gloves are processed.
- Surgical gloves are the most expensive. Whenever possible, they should be used only for procedures in which there will be contact with the bloodstream or tissues under the skin.

#### **Summary**

- Adoption of Aseptic Techniques when conducting medical procedures remains one of the major strategies for preventing infection.
- The understanding of the various procedures of proper hand washing, gloving and removal of used gloves and the wearing of proper attire is imperative for the maintenance of a sterile field.

## Module Eight - Session 2: Disinfection and Sterilization

### Learning Objectives:

By the end of this session, participants should be able to:

- List the steps of processing instruments and other items
- Explain the steps of processing instruments and other items
- Discuss the correct way of preparing 0.5% chlorine solution
- Explain the types and steps of processing instruments and other items by sterilization
- Explain the types and steps of processing instruments and other items by High-level Disinfection (HLD)
- Discuss how to appropriately store processed instruments and other items

### Session Overview

- Steps of processing instruments and other items
- Correct way of preparing 0.5% chlorine solution
- Types and steps of processing instruments and other items by sterilization
- Types and steps of processing instruments and other items by High-level Disinfection (HLD)
- Storage of processed instruments

## CONTENT

### A. Steps of processing instruments and other items

- To prevent transmission of infections via medical instruments, the following steps of instrument processing i.e.,
  - decontamination,
  - cleaning, and
  - sterilization or high level disinfection must be done properly.

#### *“Step 1: Decontamination*

- Decontamination kills many disease-causing microorganisms such as hepatitis virus and HIV, making instruments and other items safer for handling during cleaning.
- Decontamination is performed by soaking used instruments and other items in 0.5% Chlorine solution for 10 minutes.

### B. Correct way of preparing 0.5% chlorine solution

#### **MAKING A CHLORINE SOLUTION**

Use the following formula to prepare a dilute chlorine solution from liquid

$$\left[ \frac{\% \text{ Chlorine in solution}}{\% \text{ Chlorine solution desired}} \right] - 1 = \text{number parts water needed per part chlorine}$$

Example: to make a 0.5% chlorine solution from bleach with 3.5% active chlorine

$$\frac{[3.5\%]}{[0.5\%]} - 1 = 7 - 1 = 6$$

Thus, add 6 parts water to 1 part liquid bleach

**Note:**

- Instruments should not be exposed to chlorine for prolonged periods. A 10-minute time period is sufficient for decontamination.
- Large surfaces such as examination and operating tables, laboratory bench tops and other equipment that may have come in contact with blood or other body fluids also should be decontaminated. Wiping them down with a suitable disinfected towel or cloth (e.g. 0.5% chlorine or 1-2% phenol) is a practical, inexpensive way to decontaminate these items.

*“Step 2: Cleaning”*

- Cleaning instruments with detergent and water removes blood and particulate matter and improves the quality of subsequent high-level disinfection or sterilization.
- A brush should be used for cleaning most instruments. Staff members must wear thick utility gloves while cleaning instruments.

*“Step 3: Sterilization or High-level Disinfection”*

- To be effective, both sterilization and high-level disinfection (HLD) must be preceded by decontamination, careful cleaning, and thorough rinsing.
- When sterilization of instruments is not possible, HLD is the only acceptable alternative.

**C. Types and steps of processing instruments and other items by sterilization**

- Sterilization using steam, dry heat, or chemical solution destroys all microorganisms (bacteria, viruses, fungi, and parasites) including bacterial endospores, from instruments and other items.
- Sterilization is the method recommended for items that come in contact with the blood stream or tissues beneath the skin (such as reusable needles, syringes, and surgical and many delivery instruments):
- Jointed instruments, such as ring forceps, should be open or unlocked for sterilization.
- Sterilization can be done using steam (autoclaving), dry heat (oven) or chemical solutions.
- Sterilized items should then be used immediately or stored in a sterile, covered container.



### *“Steam Sterilization”*

- Instruments may be sterilized either wrapped or unwrapped;
- If items are to be wrapped before steam sterilization, use two layers of paper wrap or two layers of cotton fabric (do not use canvas);
- The unwrapped items or wrapped packs should be arranged to allow free circulation of steam.
- Steam sterilization of items is done at 121 degrees C (250 degrees F) and 106 kPa pressure (15 lbs/in<sup>2</sup>). Steam 30 minutes for wrapped, 20 minutes for unwrapped items.
- Timing should not begin until the steam sterilizer reaches the desired temperature and pressure.
- Allow unwrapped items or wrapped packs to dry before removing them from the steam sterilizer.
- Allow items to cool before storage or use.

### *“Dry Heat Sterilization”*

- Items can be wrapped in foil or double-layered cotton fabric before dry heat sterilization.
- Dry heat sterilization of items is done at 170 degrees C (340 degrees F) for 60 minutes, or 160 degrees C (320 degrees F) for 120 minutes.
- Dry heat can dull sharp instruments and needles. These items should not be sterilized at temperatures higher than 160 degrees C.
- Items should be allowed to cool before they are removed from the oven.
- Timing should not begin until the oven reaches the desired temperature.

### *“Chemical Sterilization”*

- Cover all items with correct dilution of glutaraldehyde solution (Cidex) or an 8% formaldehyde solution (least desirable because it is dangerous to breathe). **Do not use sporicidin for sterilization.**
- Jointed instruments such as Cusco speculum, ring forceps, should be opened or unlocked.
- Soak items for 10 hours for Cidex, or 24 hours for formaldehyde, or as per manufacturer's instructions.
- Nothing should be added to or removed from the chemical solution once timing has begun.
- After soaking items, rinse them with sterile water and air dry before use or storage.

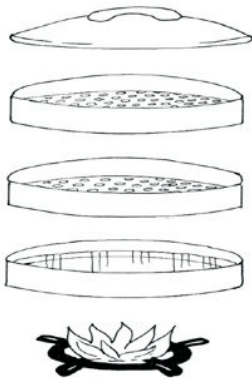
#### D. Types and steps of processing instruments and other items by High-level Disinfection (HLD)

- If sterilization is not available, high level disinfection is the only acceptable alternative for preparing instruments and other reusable items for use in PPIUD insertion.
- High-level disinfection (HLD) is effective in eliminating all microorganisms except some bacterial endospores.
- There are two methods of HLD: boiling and chemical HLD.
- After either boiling or chemical HLD procedure, items that are not used immediately should be air-dried and stored in a covered high-level disinfected container (for up to one week).

##### *“High Level Disinfection by Steaming”*

- The best method of high-level disinfection of gloves and a useful method of high-level disinfection of cannulae used during manual vacuum aspiration (MVA) is to steam them in a steamer containing one to three tiers of gloves or cannulae.
- MVA cannulae may be high-level disinfected or sterilized by other methods. However, high-level disinfection of gloves by other methods is less appropriate and not recommended.

**Figure 8.2.1 - Two-Tiered Steamer**



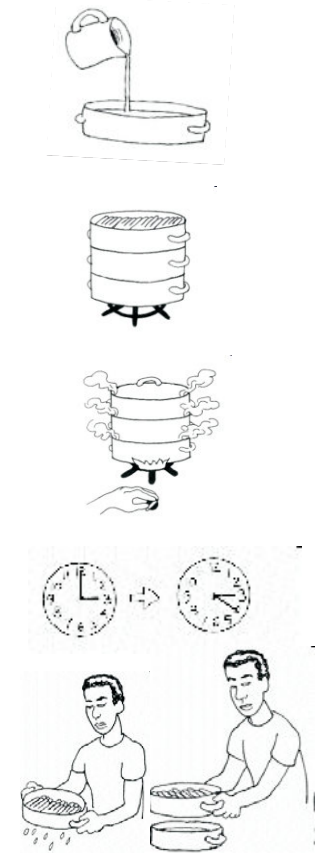
### “Steps of HLD by Steaming”

**Figure 8.2.2 – Steps of HLD by Steaming**

#### **STEPS OF HLD BY STEAMING**

These steps should be followed for steaming MVA cannulae and other materials as shown in the diagram below:

1. Decontaminate the materials to be high-level disinfected.
2. Place water in the bottom tray (which has no holes).
3. Stack the tray(s) of materials on top of the bottom tray.
4. Place the lid on the top tray and bring the water to a boil. When steam comes out between the trays, the water is boiling. Reduce the heat, but maintain the water at a rolling boil (steam should continue to come out between the trays). High heat wastes fuel and causes the water to evaporate more quickly.
5. Steam the materials for 20 minutes. Use a timer or make sure to record the time.
6. Remove each tray, shake off the excess water, and place the tray(s) on a second tray that does not have holes or contain water (a second bottom tray). (Do not place the tray containing the materials directly on the countertop, since this may contaminate them; remember, there are holes in the bottom of the tray).
7. Use the materials immediately or allow them to dry for 4–6 hours (drying may be difficult in areas of high humidity).
8. Storage: Store the materials in a covered tray or put them in a high-level disinfected container and use within one week.



### “Steps of Chemical HLD”

- All items should be covered with the correct dilution of properly stored disinfectant:
  - Glutaraldehyde solution\
  - 0.5% or 0.1% chlorine solution
  - 8% formaldehyde solution
- Joined instruments, such as ring forceps, should be opened or unlocked;
- *Chemical HLD* of items should be for 20 minutes or as per manufacturer's instructions;
- Nothing should be added to or removed from the chemical solution once timing has begun. After soaking items, rinse them with boiled water.
- Items should be air-dried before use or storage.

## **E. Storage of processed instruments**

- Proper storage of HLD or sterilized items is as important as the HLD or sterilization process itself. Therefore:
  - Items should be stored dry;
  - If possible, store processed items in an enclosed cabinet.
  - Do not store pick-up forceps in a bottle filled with antiseptic solution (microorganisms will multiply in the standing solution even if an antiseptic has been added);
  - HLD or sterilize pick-up forceps each day and store them dry in a high-level disinfected or sterile bottle.
  - Wrapped items must be considered contaminated when:
    - The package is torn or damaged
    - The wrapping is wet
    - The expiration date is exceeded.
  - Wrapped items can be used for up to one week. Wrapped items sealed in plastic can be used for up to one month.
  - Unwrapped items must be used immediately or stored in a covered sterile or HLD container (for up to one week)

### **Summary**

- The session highlighted the importance of processing instruments and other medical items in a stepwise manner to avoid contamination.
- Infections' prevention in medical settings relies on the effective decontamination and sterilization of instruments in use.

## Module Eight: Session 3: Disposal of Sharps and Waste

### Learning Objectives:

By the end of this session, participants should be able to:

- List the ways by which health workers can be injured by sharps;
- Describe actions that surgical teams can take to prevent or minimize injuries by needles/sharps;
- Discuss the proper procedures for safe use and disposal of needles/sharps;
- Describe the proper procedures for giving injections
- State the proper procedures for the use of multi-dose vials;
- Discuss how to reduce the risk of transmitting infections between clients;
- Define Housekeeping and state its importance.
- State the importance of correct disposal of waste
- Describe appropriate waste disposal.

### Session Overview

- Ways by which health workers can be injured by sharps
- Actions that surgical teams can take to prevent or minimize injuries by needles/sharps
- Proper procedures for safe use and disposal of needles/sharps
- Proper procedures for giving injections and use of multi-dose vials
- Proper procedures for the use of multi-dose vials
- Reducing the risk of transmitting infections between clients
- Definition of House-keeping and its importance
- Importance of correct disposal of waste
- Appropriate waste disposal

## CONTENT

### A. Ways by which health workers can be injured by sharps

#### *How injuries commonly occur:*

- Recapping hypodermic needles after use (this is one of the major causes of sharp-object injuries.
- Any manipulation of used sharps before disposal (such as bending, breaking or cutting hypodermic needles, which can cause the blood inside to splatter or cause staff to accidentally injure themselves)
- Accidentally sticking another staff member when there is sudden motion involving persons carrying unprotected sharps
- Leaving sharp items in areas where they are unexpected, such as on surgical drapes or bed line
- Accidental sticking or cutting during surgical procedures in which there is limited visibility of the hands, many sharp instruments are used, or sharp instruments/suture needles are used in confined spaces (such as many obstetric/gynecological and orthopedic procedures)
- Handling or disposing of waste that contains used hypodermic needles or other sharps
- Unexpected client motion at the time of injections. Always warn clients when you are about to give them an injection

- During placement of needles or sharps into disposal container that are full or do not allow for easy insertion of the items
- When the surgeon or assistant uses their fingers as a guide or when tissue is hand-held during suturing, during manual retraction of tissue/organs, or when tying suture material with the needle still attached
- When needle holders with the needle are left exposed
- Other devices that cause stick-injuries and perforation of gloves include the use of suture needle without a needle holder, wire sutures, trocars, stylets, sharp pointed scissors, sharp pointed retractors, skin hooks, penetrating towel clips, tenaculi.
- Scalpel injuries occur most frequently when instruments are handed from the user to an assistant (transferring between personnel).

## **B. Actions that surgical teams can take to prevent or minimize injuries by needles/sharps**

### ***How to prevent injuries due to sharps:***

- Handle hypodermic needles, syringes, and other sharps minimally after use, and use extreme care whenever sharps are handled.
- Avoid recapping needles and do not bend, break or cut them before disposal.
- Dispose of hypodermic needles, scalpel blades, and other sharps in puncture-resistant containers immediately (or as soon as practical) after use. (Disposal of sharps is described more fully in the next section of this module).
- Incinerate/burn or bury the container when three quarters full.
- Always wear utility gloves when disposing of sharps containers.
- Always wear utility gloves when washing sharps.
- Use the “hands-free technique” (described on the next page) to pass sharps during clinical procedures.
- Let clients know when you are going to give an injection to avoid startling client and causing an injury.
- Promote safety awareness during in service session focused on supporting behaviour change to prevent or minimize needle stick and sharp instrument injuries.
- Manipulate or reposition scalpel blades using forceps to grasp the blade.
- Consider using staples in place of suture and suture needles, if it would be an appropriate option.
- Use curved needles with a needle holder as a safer option to straight, hand held needles.
- Blunt instruments can be an alternative for preventing injuries, such as rounded point scissors, non-penetrating towel clips, blunt retractors, and synthetic sutures instead of wire sutures.
- When transferring sharps between personnel, avoid hand-to-hand transfer. Create a safety zone using a flat tray, mat, part of the instrument stand, or designated area on the field where instruments can be placed by the user and safely picked up by the assistant. ***Do not use a kidney basin from which items are hard to pick-up.***

### ***The Hands Free technique for passing Sharps during Clinical Procedures:***

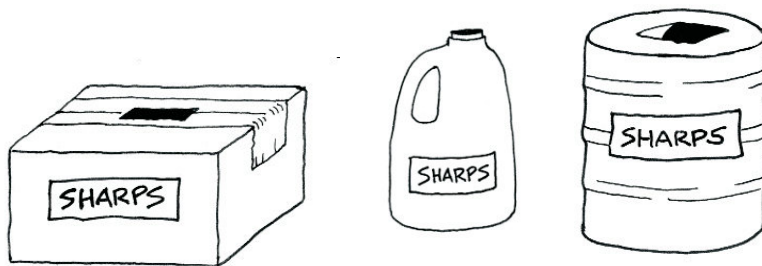
- Health care workers can accidentally stick each other if or when passing sharps during a procedure, there is sudden motion involving persons carrying unprotected sharps (such as on surgical drapes).

- Unprotected sharps should not be passed directly from one person to another.
- In the operating theatre or procedure room, pass sharp instruments and other items in such a way that the surgeon and assistant are never touching the instrument or other item at the same time (known as the hands-free technique).

### C. Proper procedures for safe use and disposal of needles/sharps

- Improper disposal of contaminated sharp objects can cause infections in the health care facility and the community.
- Make hypodermic needles and other sharps unusable by incinerating them.
- If an industrial incinerator that will destroy hypodermic needles and other sharps is not available, reduce the risk of infections by decontaminating sharps before disposal, and bury them in a pit to make it difficult for others to scavenge them.

**Figure 8.3.1 - “Sharp-disposal container, “a puncture-resistant container for**



A sharp-disposal container may be made out of a heavy cardboard box, an empty plastic jug, or a metal container.

### D. Proper procedures for giving injections and use of multi-dose vials

*Giving Injections - To reduce the risk of transmitting infections between clients:*

- Always use a new or correctly re-processed hypodermic needle and syringe every time an injection is given.
- Never change the needle without also changing the syringe between clients. Re-using the same syringe to give injections to multiple clients – even if the needle is changed – is not a safe practice.
- Before giving an injection if there is visible dirt, wash the injection site with soap and water.
- Wipe the client's skin at the injection site with an antiseptic solution to minimize the number of microorganisms and reduce the risk of infections. Using a fresh swab, wipe in a circular motion from the center outward.
- If alcohol is used, allow the alcohol to dry in order to provide maximum effectiveness in reducing microorganisms.

To avoid transmitting infections when giving IV fluids:

- Unhook the needle or catheter from the IV line, and dispose of it in a sharps-disposal container.
- Throw away the IV line and any remaining fluid. Microorganisms can survive and grow in IV fluids; if the IV line and bag/bottle of fluid are used again, infection can be transmitted to other clients.
- Never use the same IV line and fluid bag/bottle with multiple clients.
- Unexpected client motion at the time of injection can lead to accidents. Therefore, always warn clients when you are about to give an injection.

#### E. Proper procedures for the use of multi-dose vials

- Before filling a syringe from a multi-dose vial,
  - Check the vial to be sure there are no leaks or cracks;
  - Check the solution to be sure it is not cloudy and that there is no particulate matter in the vial. (Most solutions that come in vials are clear. One exception is the injectable contraceptive Depo-Provera, which is milky).
  - Wipe the top of the vial with a fresh cotton swab soaked with 60-70% alcohol; allow to dry.

#### F. Reducing the risk of transmitting infections between clients

*How to reduce the risk of transmitting infections between clients”*

- **To reduce the risk of transmitting infections between clients:**
  - Always use a new hypodermic needle and syringe every time medication is withdrawn from a multidose vial. ***Reusing the same syringe to give injections to multiple clients – even if the needle is changed is not a safe practice.***
    - **Never** leave one needle inserted in the vial cap for multiple uses. This provides a direct route for microorganisms to enter the vial and contaminate the fluid between each use.
    - Wash hands with soap and water
    - Where there is bleeding, allow the site to bleed briefly. (***There is no scientific evidence that cleaning the wound with an antiseptic or squeezing the wound decreases the risk of transmitting blood borne organisms***).
    - If a mucous membrane has been injured or splashed, flush with a large amount of water.
    - If the eyes have been splashed, irrigate with clean water, saline, or sterile irrigating solution.
    - In the absence of water, an antiseptic solution can be used to flush the area but remember that antiseptic solutions have not been proven to be any more effective than soap and water
    - Assess the injured health worker's risk for infection following exposure – depth of wound, type of instrument involved, amount and type of bodily fluid.



- If feasible, determine the HIV status of the source patient, with appropriate counselling and disclosure of serological status. This is a particularly important step in settings where resources are limited and recommended prophylactic drugs may not be readily available. Determining that the source patient is HIV negative will eliminate the need for drug therapy, its attendant side effects, costs and emotional stress of not knowing the risk following exposure or whether the drug therapy will work. Based on the assessment findings, determine the need for prophylaxis.
- Post exposure care includes voluntary counselling, HIV testing, treatment, and follow-up care.
- If the health care worker will receive antiretroviral drugs, counsel the worker about the possible side effects associated with the prophylactic drugs (ZDV) and 3TC). Although these drugs are usually well tolerated, some of the more common side effects include:
  - Stomach upset (nausea, vomiting and diarrhea), tiredness, or headache (ZDV).
  - Stomach upset (rarely, pancreatitis with 3 TC)
  - Jaundice and kidney stones in people taking ZDV; this can be reduced by drinking 48 ounces of fluids during every 24-hour period.
- Counsel the injured health worker about behaviours to prevent transmission of HIV, such as not providing blood, organ, or semen donations; abstaining from sexual intercourse. If abstinence will be difficult or not possible for the health worker, counsel her/him to use latex condoms consistently and correctly to reduce the sexual transmission of HIV.
- Encourage the injured health care worker to include their partner in counselling. In settings where breast milk substitutes are affordable, accessible, and can be safely used, women may be advised to avoid breastfeeding during the PEP period to prevent exposing their infants to HIV in the breast milk. Post-exposure care should include the following, where feasible:
  - Screening / Testing for baseline and periodically up to 6 months after exposure (e.g. at 6 weeks HIV antibody testing of the health care worker, as soon as possible after, 12 weeks, and 6 months).
  - When antiretroviral drugs are being taken for PEP, assessment of toxicity with complete blood count, kidney and liver function tests before starting treatment and at 2 weeks after starting treatment.
  - Instruct the health care staff under treatment to report any sudden or severe flu-like illness that occurs during the follow-up period.
  - Counsel the injured worker regarding her/his emotional response, fears, and/or concerns regarding the reaction of their partner or spouse.

## **G. Definition of House-keeping and its importance**

- The general cleaning and maintenance of cleanliness in a health care facility.
- In addition to cleanliness, the purpose of housekeeping is to reduce the number of microorganisms in the facility.

## **H. Importance of correct disposal of waste**

- Prevent spread of infection to clinic personnel who handle the waste and to the local community.
- Protect those who handle wastes from accidental injury;
- Provide an aesthetically pleasing atmosphere.

## **I. Appropriate waste disposal**

- Wastes from procedure rooms, delivery rooms, operating rooms and laboratories should be considered contaminated.
- Contaminated wastes should be transported to disposal sites in covered containers where available. Persons handling wastes should wear heavy gloves.
- All sharp items should be disposed in puncture-resistant containers.
- Liquid waste should be carefully poured down a utility drain or flushable toilet or latrine.
- It is best to burn or bury contaminated waste rather than use community waste collection.

## **Summary**

- All staff that come in contact with sharps and those that dispose medical waste are at risk of injury and infections
- Proper disposal of sharps, effective housekeeping within the health facility, and appropriate disposal of dry and wet wastes are essential for infection prevention.

Observing the general guidelines for housekeeping is the easiest way to keep the facility infection free.

## **MODULE NINE**

### **PROBLEM MANAGEMENT/INFORMATION AND SUPPORT DURING IUD AND IMPLANT USE**

**Session 1:** Problem Management during use of Copper bearing IUDs

**Session 2:** Problem Management during Implant Use

## Module Nine - Session 1: Problem Management during use of Copper bearing IUDs

### Learning Objectives:

By the end of this session, participants should be able to:

- List the common side effects, the occasional side effects and the warning signs requiring prompt medical attention in IUD users.
- Indicate what action should be taken medically for each side effect.
- Demonstrate through case studies and role plays ways of handling client concerns about side effects of IUDs.

### Session Overview

- Common side effects, the occasional side effects and the warning signs requiring prompt medical attention in IUDs users
- Action which should be taken medically for each side effect
- Demonstration of ways of handling client concerns about side effects of IUDs (through case studies and role plays)

### CONTENT

#### **A. Common side effects, the occasional side effects and the warning signs requiring prompt medical attention in IUDs users**

- Most side effects and other health problems associated with the use of IUDs are not serious.
- Changes in the menstrual bleeding, especially some increase in the amount and duration of the menstrual bleeding, are the most common adverse side effects.

*Common health problems and side effects associated with the use of IUDs:*

- Suspected perforation
- Bleeding changes
- Severe pain in the lower abdomen
- Pain and/or cramping
- Missing strings
- Uterine perforation
- IUD expulsion

#### **B. Action should be taken medically for each side effect**

*“Suspected perforation”*

- If perforation is suspected based on the signs such as fainting during or after insertion, pain, rapid pulse and respiration, fatigue

*Actions to be in taken in suspected perforation*

- *Refer to higher level of care*

*If intra-abdominal bleeding is suspected*

- If her vital signs are getting worse (rapid pulse, falling blood pressure, fainting) and or her haematocrit /haemoglobin are falling, refer to higher level of care without further delay.

*“Bleeding changes”*

*If there is spotting or irregular bleeding*

- Reassure that many IUD users experience irregular bleeding or spotting. This is not harmful and usually becomes less after the first 3 months
- Suggest short course of non-steroidal anti-inflammatory drugs (NSAID) such as ibuprofen 400 mg 2 times a day for 5 days (to be taken with meals)

*If there is heavy or prolonged monthly bleeding*

- Reassure that many women who use IUD experience heavy or prolonged menses. It is generally not harmful and becomes less or stops after the first 3 months of use
- For moderate short-term relief, try (one at a time):
  - Tranexamic acid 1500 mg 3 times a day for 3 days, then 1000 mg once a day for 2 days, beginning when heavy bleeding starts
  - NSAID such as ibuprofen 400 mg or 2 times a day for 5 days
  - Provide iron tablets if possible and counsel about diet high in iron

*If irregular, heavy or prolonged bleeding continues or starts after several months of normal bleeding or long after the IUD was inserted*

- Rule out underlying condition (e.g. infection or genital malignancy) and treat accordingly or refer to the specialist
- She can continue using the IUD while condition is being evaluated
- If bleeding is caused by STI or PID, she can continue using the IUD during treatment

*“Severe pain in the lower abdomen”*

*If there is suspicion of PID (list symptoms of PID)*

- Begin antibiotics immediately, using syndromic approach that involves the following:  
Ciprofloxacin 500 mg bd x 5 days  
Doxycycline 100 mg tab orally twice daily x 7 days  
Metronidazole 400 mg tab orally twice daily x 14 days
- Follow-up in 48 hours
- There is no need to remove IUD unless client wants to discontinue. If she wants it removed, take it out after 2-3 days of antibiotic treatment
- Instruct client to take all medication until it is finished
- Tell patient to return to clinic 4–7 days after completing antibiotics
- Tetracycline/Doxycycline should be taken one hour before meals or two hours after meals. Avoid antacids, dairy products, e.g. milk, and mineral preparations, e.g. calcium, when taken tetracycline
- Counsel client to avoid sexual intercourse until client and partner(s) are cured; use condoms to prevent re-infections. If STI is suspected, treat partner(s)

- If IUD is removed, counsel client regarding choice of alternative family planning method until pregnancy is desired
- A client who desires another IUD can have it inserted after she and her partner were cured.

*If there is suspicion of ectopic pregnancy (List symptoms of PID)*

- Refer to a higher level provider immediately for diagnosis and care

*“Mild Pain and/or Cramping”*

*If pain or cramps occurred since IUD insertion (first three months) and are linked to monthly bleeding*

- Re-assure client that pain and cramps are not an unusual side effect of IUD use and usually decrease over time. They are not harmful.

Give analgesic tablet (Paracetamol, Buscopan)

*If cramping continues and occurs outside of monthly bleeding*

- Evaluate for underlying health condition (infection, partial expulsion of the IUD) and treat or refer
- If no underlying condition is found and cramping is unacceptable to the client, remove the IUD and help her choose another method

***“Missing Strings”***

*If strings are neither visible nor felt and client is not pregnant*

- *Refer to higher level of care*

***“Uterine pregnancy”***

*If strings are visible*

- Inform client of your findings and explain that IUD in the uterus during pregnancy increases the risk of preterm delivery or miscarriage during the first or second trimester.
- Explain that if she is planning to continue the pregnancy, it is best to remove the IUD, although the removal procedure itself involves a small risk of miscarriage.
- If client consents, remove device by gently pulling the strings
- Refer for antenatal care, counsel client to return to clinic if abdominal pain and bleeding/spotting occurs

*If strings are not visible*

- *Refer to higher level of care*

***“IUD expulsion”***

*If strings are unusually long or stem of device is at cervical os and pregnancy is ruled out*

- Remove the IUD
- If client wants to continue using IUD, re-insert another one and follow-up in six weeks. If not, help her choose another method

*If strings are unusually long or stem of device is at cervical os, and unable to exclude pregnancy*

- Remove the IUD
- Provide barrier contraceptive
- Ask client to return to the clinic in four weeks for re-evaluation

*If client reports that IUD came out*

- Discuss whether she wants another IUD or a different method
- If she wants another IUD, she can have one inserted at any time as long as provider is reasonably certain she is not pregnant

**C. referral to higher level of care is strongly considered in acute low abdominal pain**

**Summary**

- Long-term success, as defined by satisfied clients and high continuation rates, will occur only if clinic staff recognize the importance of providing follow-up care (including counselling) and prompt management of side effects as well as other problems should they occur.
- Most side effects and other health problems associated with IUD are not life threatening.

## **Module Nine - Session 2: Problem Management during use of Contraceptive Subdermal Implants**

### **Learning Objectives:**

By the end of this session, participants should be able to:

- List the common side effects, occasional side effects and warning signs requiring prompt medical attention in implant users.
- Indicate what action should be taken medically for each side effect.
- Demonstrate through case studies and role plays ways of handling client concerns about side effects of Implant
- Demonstrate counselling clients on side effects of Implants in clear everyday language

### **Session Overview**

- Common side effects, the occasional side effects and the warning signs requiring prompt medical attention in implant users.
- Action which should be taken medically for each side effect.
- Demonstration of ways of handling client concerns about side effects of Implants (through case studies and role plays)
- Demonstration of ways of counselling clients on side effects of Implants in clear everyday language

## **CONTENT**

### **A. Introduction**

- Most side effects and other health problems associated with the use of implants are not life threatening.
- Changes in menstrual bleeding patterns are by far the most common adverse effect.
- In addition to menstrual bleeding changes, women using Jadelle<sup>R</sup> implants occasionally develop enlarged ovarian follicles. Fortunately, they rarely cause symptoms and usually are discovered only incidentally at pelvic examinations. In addition, they generally shrink and disappear spontaneously and rarely require treatment.
- Ectopic pregnancies also have occurred, although clinical studies have shown no increase in the rate of ectopic pregnancies per year among Implants users compared with women not using any contraceptive method.

### **B. Common side effects, occasional side effects and warning signs requiring prompt medical attention in Implant users**

- Common health problems and side effects associated with the use of Implant such as:
  - Pain after insertion or removal
  - Infection at the insertion site
  - Irregular or heavy bleeding
  - Severe pain in the lower abdomen
  - Headaches



- Several other conditions that may or may not be associated with the use of Implants have been reported. They include breast tenderness and/or discharge, weight gain, increased body or facial hair (hirsutism) and vaginal infection (vaginitis).

### **C. Actions to be taken medically for each side effect**

#### *“Pain after insertion or removal”*

##### *If no signs of infection:*

- Advise her to avoid pressing on the implants for a few days and never press on the Implants if tender
- Give Paracetamol for the pain

#### *“Infection at the insertion site”*

##### *If there is redness, heat, pain, pus:*

- Do not remove the implants
- Clean the infected area with soap and water or antiseptic
- Give an oral antibiotic, e.g. Amoxicillin 500 mg tds for 7 days and ask the client to return in one week
- Then if no improvement, remove the implants or refer for removal

##### *If there is an abscess:*

- Clean the infected area with antiseptic, make an incision, and drain the pus
- Treat the wound and give oral antibiotic for seven days
- Ask client to return in 7 days if she still has symptoms (heat, pain, drainage, redness). If infection is still present, remove the Implants or refer for removal. Help to choose another method

#### *“Irregular or Heavy vaginal bleeding”*

##### *If no underlying condition is suspected (Implant is still in place and bleeding started after Implant initiation):*

- Reassure the client that bleeding changes are common in women who are using Implants, they are not harmful and usually become less or stops altogether after the first year of use
- If the client finds the bleeding unacceptable and no estrogen contraindication, offer:

Client can use up to three cycles of low-dose combined oral contraceptive (pill containing the progestin levonorgestrel) the same progestin present in the Implants is best for controlling bleeding

- Give Ibuprofen 400mg bd for 5days or other non-steroidal anti-inflammatory drugs, but not aspirin
  - If bleeding is very heavy (twice as much as usual):
    - check for anaemia. If present, treat and refer
    - advise on food containing iron

- If bleeding is unacceptable to the client, help her choose another method and remove Implant

**Note:** Uterine evacuation is not necessary and is contraindicated

*If bleeding is due to gynaecological problems:*

- refer for care as appropriate

*Unexplained abnormal vaginal bleeding that suggests underlying medical condition unrelated to method use:*

- The client can continue using implant while her condition is being evaluated
- If no cause of bleeding can be found, consider stopping Implants to make diagnosis easier. Provide another method until the condition is evaluated and treated (other than hormonal method or IUD)
- Treat any underlying medical problems or refer for care. If bleeding is caused by STI or PID, she can continue using Implants and refer for treatment.

*“Severe Pain in the lower abdomen”*

*If ectopic pregnancy or another serious condition is suspected:*

- Refer for immediate diagnosis and care

*If pain is due to ovarian cyst:*

- Implants can remain in place.
- Re-assure the client that these cysts usually disappear on their own without surgery.
- To be sure there is no problem, see the client again in about three weeks if possible

*“Headaches”*

*If it is ordinary headache:*

- Suggest painkillers such as ibuprofen or paracetamol
- Reassure

*If migrainous headaches with aura (blurred vision, temporary loss of vision, seeing flashing lights or zigzag line):*

- If migraines with aura started or became worse after she began using the method, remove implants.
- Help client to choose non-hormonal contraceptive method
- Refer for care as needed

*If there is no pregnancy and amenorrhea is less than six weeks:*

- Re-assure the client that menstruation may resume within 4–6 weeks or onset of last menses
- Give follow-up appointment for 2–4 weeks

*If the client is pregnant:*

- Remove the implant
- Refer immediately for antenatal care

*Action to take on Warning Signs/Special Concerns of Implant use*

- The client should report to the nearest family planning clinic if she notices any of the following:
  - Severe lower abdominal pain
  - Heavy vaginal bleeding
  - Arm pain
  - Pus or bleeding at the insertion site (this may indicate infection)
  - Expulsion of an implant (this rarely occurs with proper placement)
    - Episodes of migraine, repeated severe headaches, or blurred vision
    - Delayed menstrual cycles after a long interval of regular cycles
    - Suspicion of pregnancy
    - Jaundice

### **Summary**

- Most of the health problems associated with implants' use are mild.
- Good counselling about these side effects enables the client to tolerate them while improving continuation rates.
- Changes in menstrual bleeding patterns are by far the most common side effect.
- Management of the side effects ranges from simple reassurance, medical treatment, to referral for further care.
- User concerns must be patiently listened to and addressed accordingly.

## **MODULE TEN**

### **RECORD KEEPING, MANAGEMENT INFORMATION SYSTEM (HMIS) AND CONTRACEPTIVE LOGISTICS MANAGEMENT SYSTEM (CLMS)**

**Session 1:** Record Keeping and Management Information System (HMIS)

**Session 2:** Contraceptive Logistics Management System (CLMS)

## **Module Ten - Session 1: Record Keeping and Management Information System (HMIS)**

### **Learning Objectives:**

By the end of this session, participants should be able to:

- Describe the HMIS
- Mention the importance of HMIS
- State the reasons for accurate record keeping and its implication for data quality
- List the advantages of Record Keeping
- Explain the disadvantages of NOT keeping records
- Explain the content of the various national record keeping forms

### **Session Overview**

- Description of the HMIS
- The importance of HMIS
- Reasons for accurate record keeping and its implication for data quality
- Advantages of Record Keeping
- Disadvantages of NOT keeping records
- Content of the various national record keeping forms

## **CONTENT**

### **A. Description of the MIS**

- This session discusses the importance of Record Keeping in FP Programme, information needed to measure programme success and inform programme or service delivery improvement.
- Health Management Information System (HMIS) is an organized way of recording, collating, and interpreting health information for planning and decision-making

### **B. Importance of MIS**

- The effective management of any programme depends on the availability of information for optimal decision making. In this regard, the setting up of MIS will provide the programme management with necessary information for decision. The quality of management decision making will be determined by the quality of MIS; it is essential for effective programme management.

### **C. Reasons for accurate record keeping and its implication for data quality**

Other uses of HMIS are:

- It provides feedback on the performance of the critical functions of the programme. Such feedback allows managers to take corrective actions when problems arise.
- It provides stakeholders with regular assessments of programme performance.
- It is useful for the measurement of programme output i.e. products or services delivered to programme participants or other such activities viewed as part of the programme's contribution to society. Examples are the number of clients served, the nature and volume of advocacy or promotional effects, numbers and types of IEC materials produced and distributed.

- It is used in the assessment of programme impact.
- It provides answer to specific management and research questions.
- It is an important monitoring tool.
- It is critical for resource allocation and evaluation.

#### **D. Advantages of Record Keeping**

Record Keeping allows the programme to:

- use for referral purposes
- Know the total number of clients
- Know the number of new clients and old clients, and to determine the rate of new acceptors and revisits for each method.
- Know the number of female clients attending the family planning clinics at the various locations in the community for comparison.
- Use data for assessment, planning, implementation, evaluation e.g.
  - give an account of commodities and determine future needs
  - determine future needs regarding staffing and facilities
  - know the progress of family planning in the community and society
  - use data for future planning
  - use data for research purpose
  - use for referral purposes

#### **E. Disadvantages of NOT keeping records**

By not keeping records, the provider would not:

- Know the total number of clients served;
- Be able to determine the rate of acceptors for each method/procedure;
- Be able to compare number of clients with other Family Planning facilities in the community;
- Be able to assess or plan for future improvements and evaluate up-to-date progress;
- Be able to supply evidence of past work;
- Be able to conduct good research due to e.g. lack of statistics;
- Give good impression of clinic activities;
- Be able to help planners determine the general needs of the clinic ;
- Be able to make planning and evaluation easy;
- Be able to obtain other adequate information in case a problem of a legal nature arises.

## **F. Content of the various national record keeping forms**

- HMIS tools are used for keeping track of various services provided by the programme and activities performed

### *Uses of the Various Types of National Family Planning HMIS Tools:*

#### *Client Record form/Instruction (Form A)*

- This form is used to record client's history

#### *Tally Sheets/daily activity summary Forms (Form B1.1 & B1.2)*

- This is used to record services provided to client at the facility level. Information in this sheet is summed up at the end of every day and this summation should be transferred into the monthly summary sheets.

#### *Monthly Summary Form (Form C1.1 & C1.2)*

- This form is to be used for compilation of data in the Tally/daily Activity Summary Form, i.e. Forms B1.1 & B 1.2. It should be completed monthly by the responsible health worker in the facility.

#### *Facility Based Referral Form (Form D)*

- It is used by clinical service providers or outreach workers who provide clinical services to refer a client to a referral centre where further services can be obtained. This form is designed in a way that enable service providers keep track of how many referrals they have made and how many of these referrals have gone to the points of referral and follow-up. It enables providers keep track of clients for follow up purposes.

#### *Quarterly Summary Form (Form E)*

- This form is used for compilation of data in the Monthly Summary Form (C1.1 & C1.2). It should be completed monthly or at the end of the quarter by the responsible health worker in the facility.

#### *Annual Summary forms (Form F)*

- This is used for compilation of the data in the quarterly summary form. It should be a summary of all quarterly reports for the year in question.

#### *Outreach activity Form (Form G)*

- This is used for obtaining a record of reproductive health outreach activities undertaken by individual health worker (peer educator, community health extension worker etc) during the month in question.

#### *Monthly Outreach Summary Form (Form H.1)*

- This is used for summarizing all reproductive health outreach activities undertaken by individual health workers (peer educator, community health extension worker etc.) during the month in question. This form is filled by the supervising officer, and submitted to the project coordinator, who would use the information generated for programme planning and report writing.

*Quarterly/annual Outreach Summary form (Form H.2)*

- This form summarizes all outreach reproductive health activities carried out by health workers during the quarter of year under reference.

*Outreach Referral Forms (Form J)*

- To be used by clinical service providers or outreach workers to refer a client to a referral centre, where further services can be obtained

*Appointment Card (Form K)*

- This card is used by the service provider to enter appointments for the client.

**Summary**

Summarize the session by stating that:

- Record Keeping in FP Programme helps to generate information needed to measure programme success and inform programme or service delivery improvement.
- Effective management of FP programme depends on availability of information for optimal decision-making.
- The setting up of HMIS will provide the programme management with necessary information for decision. The quality of management decision-making will be determined by the quality of HMIS.



## **Module Ten - Session 2: Contraceptive Logistics Management System (CLMS)**

### **Learning Objectives:**

By the end of this session, participants should be able to:

- Explain logistics management
- State the objectives of the CLMS;
- Describe National Contraceptive Logistics Management system (CLMS)
- Demonstrate use of CLMS tools

### **Session Overview**

- Introduction
- Logistics management
- Objectives of the CLMS;
- The National Contraceptive Logistics Management System (CLMS)
- Demonstration of use of CLMS tools

## **CONTENT**

### **A. Logistics management**

- A logistics management system is an organized system that uses data and information gathered from various communities and service sites to provide a steady supply of consumables that are required to maintain uninterrupted services in those communities.
- The Contraceptive Logistics Management System (CLMS) provides commodities for effective contraceptive services at all service points, ensuring that all Nigerians are able to receive the contraceptives they need through their service delivery point or community based agents (CBA).

### **B. Objectives of CLMS system:**

- Enhanced distribution of a complete range of family planning methods through the different levels of the supply system (federal central contraceptive warehouse, state stores, local government store (LGA) and service delivery point (SDP)
- Sustained availability of contraceptives with adequate stock levels to meet demand at all times
- Expand access to a complete range of contraceptive methods with greater choice for clients
- Improved ordering and stock management, ensuring that requests correspond to actual need
- Increased capacity at all levels of the system to manage contraceptive supply
- Adequate flow of essential information on the movement of contraceptives through the system
- Improved contraceptive quality throughout the supply chain through procurement standards and proper storage.
- Reduced waste and increased efficiency throughout the supply chain

## C. The National Contraceptive Logistics Management System (CLMS)

### Contraceptive Security

- This is guaranteed by a programme's ability to:
  - Accurately estimate requirements
  - Control financial resources
  - Technical capacity to procure products
  - Distribute products to the customer for the medium to long-term
  - Guarantee maximizing quality through good storage practices
  - Guarantee maximizing quality through Inventory control
  - Ensure maximizing quality through supervision of supplies

### Flow of contraceptives through the public sector supply system

- The CLMS focuses on forecasting and procuring the right contraceptive quantities, storing and distributing them through all levels of the health system and delivering them to clients, as displayed in Figure 10.2.1.

### Contraceptive Commodities Selection

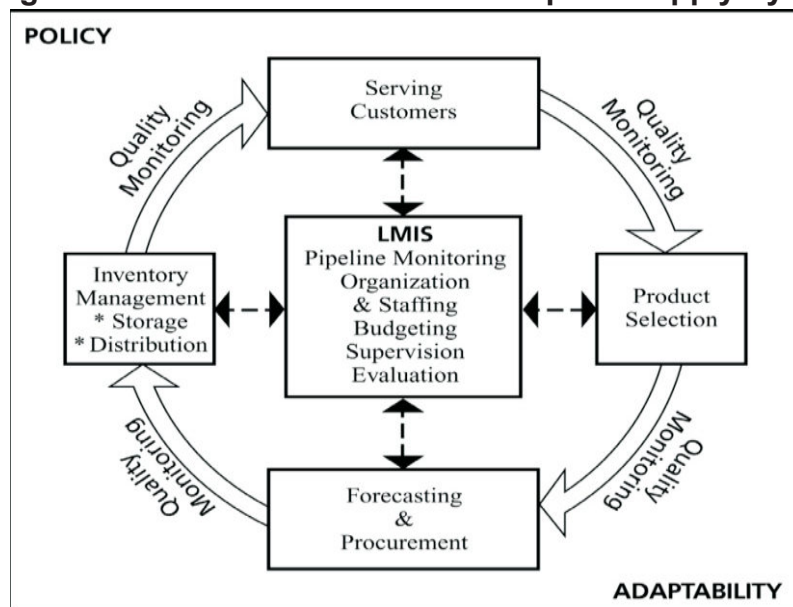
- Selection depends on factors such as the pattern of: clients' preferences, the capacity of service providers to offer wide range of FP methods and the quality of care.

### Contraceptive Commodities Forecasting and Procurement

- Once the commodities to be procured are determined, the next step is to ascertain the quantities required for procurement.
- The process of determining those quantities to procure is what is called forecasting.
- Forecasting is usually done at LGA or state levels and covers a period of more than one year. The following data sources are used to forecast:
  - *Logistics data:* This is applied in availability of consumption and stock position.

*Demographic data:* this takes into account the population being served and the extent of unmet need for FP in the area.

**Figure 10.2.1: The National Contraceptive Supply System**



Source: FMOH

- *Demographic data:* this takes into account the population being served and the extent of unmet need for FP in the area.
- *Service statistics:* This is very important in forecasting because it helps inform the project managers whether there is the need to recruit more staff to achieve the goals of the forecast or to reduce on expected consumption due to limited staff in the field.
- *Targets:* Every service point should have annual targets in volume of services to be rendered, which will derive from LGA and State targets.
- Once the forecast has been discussed and approved, then a procurement plan is developed.

### *Contraceptive Commodities Distribution and Storage*

- The commodities distribution process begins when the commodities are sent from the manufacturers or suppliers and ends when the commodity consumption information is sent to the Central Medical store.
- An effective system should not only maintain a constant supply of the commodities but also keep the commodities in good condition throughout the distribution process, minimize loss due to spoilage and expiry, maintain accurate records, reduce theft and fraud and provide information for forecasting future commodity needs.

### *Contraceptive commodity consumption*

- The CLMS delivers the correct commodities to the service delivery points.
- Rational use of the commodities requires that FP clients receive FP methods that are appropriate to their needs and choices, in adequate doses that meet their individual requirements, for the adequate period of time, at the lowest cost to them and their community.

### *Management Support*

- The commodity logistics management cycle is driven by factors that must be in place for the system to operate smoothly.
- These factors include:
  - competent human resources,
  - sufficient finances to fund the activities and purchase the commodities, a functional logistics management information system that provides vital information for planning, and
  - managerial support in form of supervision and evaluation.

### **Summary**

- Prompt and regular remittance of data compiled from good records kept on contraceptive services rendered at service points to the CBA- (community based agent) Supervisor helps the CLMS to place orders for adequate quantity of contraceptive commodities from manufacturers, which are then distributed to the service sites to ensure uninterrupted availability of services to clients.

## Clinical Incident Reporting, Investigation and Management in family planning

A clinical incident is defined as an event or circumstance that could have unintended harm to a client or a compliant, loss or damage. Client safety has been, and still is, a cause for concern in health-care systems all over the world. Family planning services is a clinical procedure which involves the administration of medicines or devices by clinicians who have the requisite clinical and counselling skills to deliver these services. Incident reporting systems have been a key tool to improve safety and enhance institutional/organizational learning from documented incidents in a range of high-risk organizations

### Risk grading an incident

In addition to determining the type of incident that has occurred, it is important to distinguish incidents by their actual or potential impact on a client. This is because the actual or potential consequence of an incident determines a proportional response – or level of investigation. The impact of an incident on a client is determined by assigning it a score based on its potential or actual consequences.

Consequence score	1	2	3	4
Descriptor	<b>Minor</b>	<b>Moderate</b>	<b>Major</b>	<b>Critical</b>
Actual or potential client impact	Minor injury or illness, requiring minor intervention, whereby it is a single isolated incident	Moderate injury requiring professional intervention, whereby it is a single isolated incident	Major injury leading to long-term incapacity /disability Mismanagement of client care with long-term effects	Incident leading to death Multiple permanent injuries or irreversible health effects

*Risk-grading matrix*

### Levels of investigation

A risk grading determines the proportionate response to an incident. There are 3 levels of investigation that correspond with each possible risk grading. The personnel who conducts the investigation and the process for ensuring investigation is received and learning disseminated also depends on the risk grading.

**Level 1** investigations (for Red incidents) are very serious and will require the highest local government officer to be notified. It will require the following actions and documents: An investigation report including root cause analysis, action plan and client case notes

**Level 2** investigations are for incidents that have received a consequence score of 2, and have been assigned an Amber risk rating. Local procedures for investigation should describe 'what, who, where, why, how and when' the incident occurred, and make recommendations for remedial action.

**Level 3** investigations are for incidents that have received a consequence score of 1, and have been assigned a Green risk grading. Isolated green incidents do not require investigation. However, if a trend of green incidents emerges this may require investigation.

## Clinical Incident Reporting Format

<p>Instructions: This form requires quick and basic information about the incident, it is NOT an investigation. It should be completed and appropriately reported to the in charge of the Health clinic or relevant state FP Coordinator <b>immediately</b> following an incident.</p>		
<b>1. Initial details</b>	Date of incident (dd/mm/yyyy)	
	State / LGA	
	Name of Health facility or hospital	
<b>2. Client details</b>	Name of client	
	Sex	
	Age	
	Gestation (weeks) if pregnant	
	Service	
	Eventual outcome (for adult) eg fatality, no fatality or unknown	
	Eventual outcome for neonate (if applicable)	
<b>3. Incident type</b>	Was this a clinical incident? Eg Infection, expulsion of contraceptive device, drug reaction, uterine perforation, bleeding from insertion sites etc	
	Details	
	Did it relate to a product?	
	Product name	
	Product type	
<b>4. Risk grading</b>	<b>Minor, Moderate or severe/Critical</b>	
<b>5. Primary provider information</b>	Primary provider name	
	Role/designation	
	Contract of staff (fulltime/Part-time/intern)	
<b>6. Brief description</b>	Brief Description (2-3 sentences)	
	Transfer? To PHC, CHC, General hospital or Teaching hospital or private hospital	
<b>7. Submission</b>	Date reported	
	Reported by	
	Reported to	