

# Resource Manual on Flash Flood Risk Management

FOR MOUNTAINS AND PEOPLE



## Module 3: Structural Measures



# About ICIMOD

The International Centre for Integrated Mountain Development, ICIMOD, is a regional knowledge development and learning centre serving the eight regional member countries of the Hindu Kush Himalayas – Afghanistan, Bangladesh, Bhutan, China, India, Myanmar, Nepal, and Pakistan – and based in Kathmandu, Nepal. Globalization and climate change have an increasing influence on the stability of fragile mountain ecosystems and the livelihoods of mountain people. ICIMOD aims to assist mountain people to understand these changes, adapt to them, and make the most of new opportunities, while addressing upstream-downstream issues. We support regional transboundary programmes through partnership with regional partner institutions, facilitate the exchange of experience, and serve as a regional knowledge hub. We strengthen networking among regional and global centres of excellence. Overall, we are working to develop an economically and environmentally sound mountain ecosystem to improve the living standards of mountain populations and to sustain vital ecosystem services for the billions of people living downstream – now, and for the future.



ICIMOD gratefully acknowledges the support of its core and programme donors: the Governments of Afghanistan, Austria, Bangladesh, Bhutan, China, Germany, India, Myanmar, Nepal, Norway, Pakistan, Sweden, and Switzerland, and the International Fund for Agricultural Development (IFAD).

# Resource Manual on Flash Flood Risk Management

## Module 3: Structural Measures

Arun Bhakta Shrestha  
Ezee GC  
Rajendra Prasad Adhikary  
Sundar Kumar Rai

**Published by**

International Centre for Integrated Mountain Development  
GPO Box 3226, Kathmandu, Nepal

**Copyright © 2012**

International Centre for Integrated Mountain Development (ICIMOD)  
All rights reserved. Published 2012

**ISBN** 978 92 9115 265 0 (printed)  
978 92 9115 266 7 (electronic)

**LCCN** 2012-323209

**Cover photo:** Sundar Kumar Rai

**Printed and bound in Nepal by**

Hill Side Press (P) Ltd., Kathmandu, Nepal

**Production team**

Andrea Perlis (Senior editor)  
A Beatrice Murray (Consultant editor)  
Amy Sellmyer (Proofreader)  
Dharma R Maharjan (Layout and design)  
Asha Kaji Thaku (Editorial assistant)

**Note**

This publication may be reproduced in whole or in part and in any form for educational or non-profit purposes without special permission from the copyright holder, provided acknowledgement of the source is made. ICIMOD would appreciate receiving a copy of any publication that uses this publication as a source. No use of this publication may be made for resale or for any other commercial purpose whatsoever without prior permission in writing from ICIMOD.

The views and interpretations in this publication are those of the author(s). They are not attributable to ICIMOD and do not imply the expression of any opinion concerning the legal status of any country, territory, city or area of its authorities, or concerning the delimitation of its frontiers or boundaries, or the endorsement of any product.

This publication is available in electronic form at [www.icimod.org/publications](http://www.icimod.org/publications)

**Citation:** Shrestha, AB; GC, E; Adhikary, RP; Rai, SK (2012) *Resource manual on flash flood risk management – Module 3: Structural measures*. Kathmandu: ICIMOD

# Contents

Foreword	v
About This Module	vi
Acknowledgements	vii
Acronyms and Abbreviations	viii
Some Key Terms	ix
Chapter 1: Introduction	1
Major Factors Contributing to Flash Floods	1
Flood Risk Management	3
The Resource Manual	4
Chapter 2: Landslides and Debris Flows	5
What is a Landslide?	5
Mechanism of Landslide Formation	7
Factors Contributing to the Development of Landslides	8
Mitigation Measures	8
Chapter 3: Landslide Dam Lakes and Glacial Lakes	11
Landslide Dam Lakes	11
Glacial Lakes	12
Chapter 4: Bioengineering Measures	15
Functions of Vegetation	15
Bioengineering in Flash Flood Risk Management	16
Common Bioengineering Techniques in the Hindu Kush Himalayas	19
Chapter 5: Physical Methods for Slope Stabilization and Erosion Control	30
Terracing	30
Diversions	36
Grassed Waterways	38
Conservation Ponds	38
Retaining Walls	44
Drop Structures	49
Sabo Dams	54
Gully Control	54
Trail Improvement	58

Chapter 6: Physical Methods for River Training	60
Transversal Protection Structures	60
Longitudinal Protection Structures	67
Other Protection Structures	74
Chapter 7: Structural Measures for Flood Management in the Context of Integrated Water Resources Management	78
Integrated Flood Management	78
Passive Flood Control Measures	79
Flood Storage Reservoirs	79
River Corridor Rehabilitation and Restoration	81
References	83



# Foreword

The Hindu Kush Himalayan (HKH) region is endowed with plentiful natural resources, including an abundant amount of water. At the same time, the region is prone to a wide range of water-related and other natural hazards, including landslides, avalanches, flooding, and earthquakes, which result from the unstable geological conditions and steep topography combined with often extreme weather. Among these, flash floods are particularly challenging for communities.

Flash floods are severe flood events that occur with little warning. They can be triggered by intense rainfall, extremely rapid snow melt, failure of natural or artificial dams, and outbursts of glacial lakes. The frequent occurrence of flash floods in the Hindu Kush Himalayan region poses a severe threat to lives, livelihoods, and infrastructure, both in the mountains and downstream. Vulnerable groups such as the poor, women, children, the elderly, and people with disabilities are often the hardest hit. Flash floods tend to carry much higher amounts of debris with them than normal floods and as a result cause more damage to hydropower stations, roads, bridges, buildings, and other infrastructure.

Since its establishment in 1983, ICIMOD has explored different ways to reduce the risk of disasters from natural hazards and the physical and social vulnerability of the people in the region. Approaches have included training courses, hazard mapping, and vulnerability assessments as well as fostering dialogue among stakeholders and developing materials for capacity building.

ICIMOD, in collaboration with various partners, has compiled and published resource materials on flash flood risk management in order to support capacity development, and especially to support the training of planners and practitioners. In 2008, ICIMOD published two modules of a resource manual on flash flood risk management which focused on community-based management and non-structural measures. These were followed by a training of trainers manual based on the resource materials. The present publication is the third module of the resource manual and deals with structural measures. The publication was produced as a part of the project 'Flash Flood Risk Reduction – Strengthening Capacity in the Hindu Kush Himalayas', supported by the United States Agency for International Development, Office for Foreign Disaster Assistance (USAID/OFDA). We hope that this new volume will be useful for practitioners and will make a meaningful contribution towards reducing disaster risk and providing greater physical security for the people of this vulnerable region.



**David Molden**  
Director General, ICIMOD

# About This Module

Flash floods are among the most destructive natural disasters in the Hindu Kush Himalayan region. They are sudden events that allow very little time to react, and often occur in remote and isolated mountain catchments where few, if any, institutions exist that are equipped to deal with disaster mitigation, and where relief agencies are either absent or have limited presence and capacity. Flash flood mitigation is generally addressed by community-based organizations, local non-governmental organizations, or district and local level staff in government organizations. But these groups often lack adequate understanding of the processes causing flash floods and knowledge of flash flood risk management measures. Building the capacity of people working directly in flash-flood-prone catchments will help to reduce the flash flood risk in the region.

The Resource Manual on Flash Flood Risk Management provides the materials needed to help people working in risk prone areas understand the problem and manage the risk. The manual is published in three parts. The first and second modules (published in 2008) focused on community-based management and non-structural measures for managing flash flood risk. The present, third, module focuses on structural measures for flash flood risk management. The material is divided into seven chapters: Chapter 1 describes the types of flash flood that occur in the region and the most important contributing factors and summarizes the major approaches in flash flood risk management; Chapters 2 and 3 describe measures to manage the risk from landslides and debris flows and from landslide dam lakes and glacial lakes; Chapters 4 to 6 discuss bioengineering techniques, physical measures for slope stabilization and erosion control, and physical measures for river training; and finally Chapter 7 presents the concept of integrated flood management as a component of integrated water resource management. The manual emphasizes throughout that structural measures are most effective and sustainable when implemented together with appropriate non-structural measures.

The resource manual is aimed at junior to mid-level professionals with a civil engineering background. The aim is to build the capacity of people working in district-level government and non-governmental organizations on flash flood risk management. The measures described are simple yet effective. They were selected on the basis of being able to be implemented using local and low-cost materials with a minimum of external materials and technical support, and having a low environmental impact.



# Acknowledgements

This manual is an output of the project 'Flash Flood Risk Reduction – Strengthening Capacity in the Hindu Kush Himalayas', which was supported by the United States Agency for International Development, Office for Foreign Disaster Assistance (USAID/OFDA).

Our sincere thanks go to Jeebachh Yadav and Gita Khatri for their valuable contributions to the manual; to Professor Hubert Holzmann of the University of Natural Resources and Applied Life Sciences, Austria, and Professor Marco Borga of the University of Padua, Italy, for their very useful suggestions; to the Department of Water Induced Disaster Prevention (DWIDP), Nepal, for providing essential resources; and to all those who contributed photographs.

We are grateful to the many ICIMOD colleagues who contributed to the manual, especially Rajesh Thapa and Sagar Ratna Bajracharya who provided important support and helped in preparing the draft document. Our thanks go especially to Professor Hua Ouyang, then Programme Manager for Integrated Water and Hazard Management, for seeing through the completion of the module, and to all the staff in this programme who supported its preparation.

Finally, we would like to express our heartfelt thanks to the many other colleagues, both within and outside ICIMOD, who read the manuscript and provided valuable comments and suggestions.

# Acronyms and Abbreviations

BCM	Banked cubic metre
c/c	Centre-to-centre
GLOF	Glacial lake outburst flood
HKH	Hindu Kush Himalayas
IFM	Integrated flood management
ICIMOD	International Centre for Integrated Mountain Development
IWRM	Integrated water resource management
LCM	Loose cubic metre
LDOF	Landslide dam outburst flood

# Some Key Terms

<b>Bioengineering</b>	The application of engineering design and technology to living systems; in terms of natural hazard mitigation, it refers to the combination of biological, mechanical, and ecological concepts to reduce or control erosion, protect soil, and stabilize slopes using vegetation or a combination of vegetation and construction materials
<b>Debris flow</b>	A rapid mass movement of loose soil, rocks, and organic material along with entrapped air and water forming a slurry that flows downslope
<b>Disaster</b>	A serious disruption of the functioning of a community or a society causing widespread human, material, economic, or environmental losses which exceed the ability of the affected community or society to cope using its own resources
<b>Disaster mitigation</b>	Steps taken to contain or reduce the effects of an anticipated or already occurred disaster; involves various levels such as individuals, groups, and communities; actions taken depend in part on the perceptions of risk of those exposed
<b>Disaster preparedness</b>	The knowledge and capacities developed by governments, professional response and recovery organizations, communities, and individuals to effectively anticipate, respond to, and recover from the impacts of likely, imminent, or current hazard events or conditions
<b>Disaster risk</b>	The potential disaster losses, in lives, health status, livelihoods, assets, and services, which could occur to a particular community or a society over some specified future time period
<b>Disaster risk reduction</b>	The concept and practice of reducing disaster risks through systematic efforts to analyse and manage the causal factors, including through reduced exposure to hazards, lessened vulnerability of people and property, wise management of land and the environment, and improved preparedness for adverse events
<b>Factor of safety</b>	For a rock slope, the ratio of the total force resisting sliding to the total force tending to induce sliding
<b>Flash flood</b>	Severe, short-lived flood events triggered by extreme cloudbursts, glacial lake outbursts, or the failure of artificial dams or dams caused by landslides, debris, ice, or snow; flash floods can have impacts hundreds of kilometres downstream, although the warning time available is counted in minutes or, at the most, hours
<b>Landslide hazard</b>	A measure of the probability of a landslide occurring at a particular location within a particular time
<b>Landslide risk</b>	The probable extent of damage if a landslide occurs; it is a function of the hazard probability and the damage potential
<b>Landslide dam</b>	A natural river dam formed by the rock, earth, debris, and/or mud transported by a landslide; easily formed in the steep, narrow valleys of high rugged mountains and can fail catastrophically causing major downstream flooding and loss of life
<b>Mass movement (gravitational mass movement)</b>	The downhill movement of surface materials under the influence of gravity but assisted by buoyancy due to rainfall or snow melt; see also landslide

<b>Mitigation measures</b>	Structural and non-structural measures undertaken to limit the adverse impact of natural hazards, environmental degradation, and technological hazards; sustained actions taken to reduce or eliminate a long-term risk to people, infrastructure, and property from hazards and their effects; measures taken in advance of a disaster to decrease or eliminate its impact on society and the environment
<b>Natural hazard</b>	Natural process or phenomenon that may cause loss of life, injury or other health impacts, property damage, loss of livelihoods and services, social and economic disruption, or environmental damage
<b>Non-structural</b>	Actions to reduce the effects of floods using non-physical solutions such as land use planning, floodplain zoning, forecasting, advance warning systems, and flood insurance
<b>Slide (sometimes 'landslide')</b>	Mass movement with a distinct surface of rupture separating the slide material from more stable underlying material (slope failure); the downward sliding material is usually relatively dry
<b>Soil conservation</b>	The set of management strategies for the prevention of soil being eroded from the earth's surface or becoming chemically altered by overuse
<b>Soil erosion</b>	The washing away of soil by currents of water, wind, or snow
<b>Structural measures</b>	Actions to reduce the effects of floods by physical interventions such as retention basins, embankments, dredging, diversions, dams, levees, floodwalls, elevating buildings, and flood-proofing

# Chapter 1: Introduction

Flash floods are sudden and intense surges of water that rise and fall very rapidly along a river course (see Box 1). They differ from riverine floods in terms of their rapid onset and decline, high intensity, and unpredictability as well as their usually more localized impact in hill and mountain areas rather than the plains. The flood wave moves at high velocity, often with a high load of debris, and can thus be extremely destructive, damaging buildings and other infrastructure; washing away fields, crops, and animals; and causing loss of life. Flash floods often occur in remote mountain catchments far from rescue services. They are among the most common natural hazards in the Hindu Kush Himalayan (HKH) region, but they are highly unpredictable and leave little time for warning and evacuation, making it difficult to mitigate their effects.

## Major Factors Contributing to Flash Floods

Flash floods in the Hindu Kush Himalayan region have a variety of causes, the main ones being localized intense rainfall, rapid melting of snow, and failure of natural or artificial dams or breakout of ice jams on watercourses. A number of meteorological, geological, and hydrological or hydraulic factors contribute to the development of such floods. The first is the seasonal (monsoon) rainfall and cloudbursts that occur in the mountain region, compounded by the high and rapid runoff from areas with steep slopes, an impermeable surface, saturated and/or compacted top soil, and lack of vegetative cover. Second, landslides and debris flows, which are also common in mountain areas, can form unstable dams across rivers, leading to the formation of temporary lakes and the development of a flash flood when the dam collapses. Bridges can also trap debris and obstruct flow, leading to inundation upstream followed by collapse of the debris accumulation and a flash flood as a result. Similarly, the development of glacial lakes behind unstable moraine dams poses a threat of a specific type of flash flood – a glacial lake outburst flood (GLOF) – when the moraine dam collapses (Ives et al. 2010). All of these can be compounded by factors related to people’s use of the landscape – anthropogenic factors – which increase the intensity and impact of the flood. These different factors are discussed in more detail in the following paragraphs.

### Intense rainfall

Intense rainfall resulting from cloudbursts, monsoon depressions, or stationary monsoon troughs is a common cause of flash floods in the Himalayan region. During the summer, humid winds flow from the Indian Ocean to the region, which results in intensive orographic rainfall on the southern aspect of the mountains. Intense rainfall in a small catchment can lead to a rapid rise in the water level in streams, especially where watercourses are narrow. Impervious soil surfaces increase the rate of runoff, and steep slopes result in acceleration of water velocity and a high rate of discharge downstream in the form of a flash flood. The flash flood event in the Kulekhani catchment of central Nepal in July 1993 is an example of the type of damage that can be caused by flash floods resulting from intense rainfall (see Box 2).

### Box 1: What makes a flood a flash flood?

Intense short-lived precipitation or sudden release of a mass of water compounded by:

- increased impervious cover
  - increased stream density
  - increased slope
- and
- decreased channel length
  - decreased surface roughness
  - decreased vegetation

### Box 2: Flash flood in central Nepal, 19–20 July 1993

In July 1993, the Kulekhani catchment in central Nepal experienced intense rain, which caused several devastating flash floods that transported high loads of debris and sediment into the reservoir of Nepal’s only storage-type hydropower station, thereby reducing its life by several decades. Other installations of the power plant were severely damaged. The highway joining the capital city to the rest of the country was seriously damaged, with several bridges and kilometres of paving washed away. Fourteen hundred lives were lost. The total impact was so enormous that it pushed the country back in its development efforts by several years.

Source: Dhital et al. 1993

## Rapid snowmelt

Especially in the western Himalayas and Karakoram mountains, rapid melting of snow can have a similar impact to intense precipitation. These areas experience considerably more winter precipitation than in the east of the region. Temperatures can rise very rapidly in the early summer leading to rapid melt of snow and high runoff from the bare rocky slopes. This type of flash flood is well-known in areas like Chitral, where communities may have memories and knowledge of potential flood paths reaching back through generations (Dekens 2007).

## Landslide dam outburst

Landslides and debris flows are very common in the Hindu Kush Himalayan region. Weak geological structures, active tectonic forces, steep and fragile topography, heavy seasonal rainfall, and river bank erosion are the major factors responsible. Deposits from landslides and debris flows can block a narrow river course to create a natural dam resulting in the formation of a temporary reservoir upstream. The water level in the reservoir will rise due to the continuous inflow from the river. When the water overtops the dam, or its weight exceeds the holding capacity of the dam, the dam can burst resulting in a sudden torrent of water downstream – a landslide dam outburst flood (LDOF). Landslide dam outbursts are generally random and cannot be predicted with precision. The Yigong LDOF in 2000 in Tibet Autonomous Region, China (see Box 3), the Tsatichhu LDOF in 2004 in Bhutan, and the Pareechu LDOF in 2005 in Tibet Autonomous Region are notable examples of large LDOF events in the region (Shrestha 2008).

## Glacial lake outburst

As in many parts of the world, glaciers in much of the HKH region are retreating and thinning, a phenomenon now accelerated by climate change (Mool et al. 2001; Xu et al. 2007; Eriksson 2009). This has led to the formation of glacial lakes behind the end moraines that formed when the glaciers were at their maximum. The moraine dams are composed of unconsolidated boulders, gravel, sands, and silt and are thus structurally fragile and potentially subject to catastrophic failure. The collapse of a moraine dam can result in the sudden release of a large amount of water and debris – a glacial lake outburst flood (GLOF). The distribution of glacial lakes in the Hindu Kush Himalayan region and the potential for outburst is described in some detail in Ives et al. (2010) and ICIMOD (2011). Though these types of flash floods are not very frequent in the region, they threaten populated areas downstream with potentially serious consequences. The Zhangazanbo GLOF in China in 1981 is a notable example of a GLOF that caused significant damage. The flood damaged the highway and bridges below the lake up to the Sunkoshi power station, including the Friendship Bridge between Nepal and China and the diversion weir of the Sunkoshi hydropower station, and the erosion and sedimentation led to a marked change in the landform downstream (Shrestha 2008). The Dig Tsho GLOF in Bhutan is a further example (see Box 4).

### Box 3: Yigong landslide dam outburst flood, Tibet Autonomous Region, China, 10 June 2000

One of the most striking examples of a LDOF took place on the Yigong River in eastern Tibet in 2000. As a result of a sudden increase in temperature, a huge amount of snow and ice melted in the region, which led to a massive, complex landslide on 9 April in the upper part of the Zhamulongba watershed on the Yigong River, a tributary of the Yarlung Zangbo River. Within eight minutes, about 300 million cubic metres of debris, soil, and ice was dumped across the river bed, forming a landslide dam 100 m high, 1.5 km wide (along the river), and 2.6 km long (across the river) (Shang et al. 2003). The blocked river formed a lake behind the dam; the inflow from the river was about 100 m<sup>3</sup> per second and the lake level rose by about a metre per day. An attempt was made to dig a large trench to release the water but this failed. On 10 June 2000, the dam broke leading to a huge flash flood downstream. The flood was 1.26 × 10<sup>5</sup> m<sup>3</sup>/s, with a maximum depth of 57 m and maximum velocity of 11.0 m/s. The peak flood was 36 times greater than the normal flood. Tongmai Bridge, the highway between Yigong Tea Farming Base and Pailong County, and two suspension bridges in Medong County were destroyed. There were no injuries or deaths on Chinese territory, but on the Indian side of the border, the damage was on a scale seldom seen and resulted in the deaths of 30 people, with more than 100 missing. The flood in the Brahmaputra River as it entered India was 1.35 × 10<sup>5</sup> m<sup>3</sup>/s (Zhu and Li 2000; Zhu et al. 2003). More than 50,000 people in five districts in Arunachal Pradesh were rendered homeless, and more than 20 large bridges, lifelines for the people, were washed away. The total economic loss was estimated at more than USD 22.9 million.

Source: Shrestha 2008

## Anthropogenic factors

In addition to natural factors, there are a number of anthropogenic factors that either contribute to creating the conditions that favour the development of flash floods or increase the associated risk, in particular settlements on flood plains, urbanization, deforestation, and failure to maintain or manage drainage systems (Shrestha 2008). Many of these are the direct result of population growth and the associated pressure on natural resources and land for food production and development. For example, deforestation and soil erosion in mountain and hill regions as a result of increased farming on marginal lands, demand for fuel, and poor construction of roads and trails, means an increase in landslides and slips and the associated potential for the creation of landslide dams. Similarly, poor management of watersheds, introduction of intensive agricultural practices, and poor land use practices leading to deforestation, degradation, and soil compaction or loss (see, for example, Mehta 2007; Dixit 2003), as well as building footprints that reduce infiltration and failure to maintain drainage systems, can all lead to decreased retention of precipitation and higher runoff, directly contributing to flash floods. Poorly planned infrastructure construction, such as the construction of bridges (especially low truss or box bridges) across narrow river channels and altering of water channels, can also contribute to the development of flash floods by hindering the free flow of water and debris and causing blockages which can burst out. The failure of man-made structures such as dams, embankments, and water reservoirs can also be a direct cause of flash floods (see Box 5).

In addition to factors that increase the likelihood of flash floods occurring, the associated risk is also increasing as a result of, for example, increased urbanization in mountain areas; location of settlements, roads, and infrastructure close to narrow water courses and on floodplains; and lack of awareness of migrant populations of local risk factors.

## Flood Risk Management

Flood risk is a combination of the probability of a flood occurring (the hazard) and of the potential adverse consequences of the flood for human health, the environment, cultural heritage, and economic activity (the vulnerability) (FRM 2009). The combination of these factors gives a measure of the risk, the likelihood and likely cost of damage occurring to people and property. Thus flood risk management has two major aspects: changing the conditions so that a flood is less likely to occur, and reducing the vulnerability of people and property if a flood does occur. When considering measures to reduce risk, it is necessary to achieve a balance between the economic, social, and environmental dimensions (Klijn et al. 2009).

Measures to reduce flood risk can be divided into two categories: non-structural and structural. A complete plan for flood risk management usually contains elements of both approaches.

### Box 4: Dig Tsho glacial lake outburst flood, Nepal, 4 August 1985

The Dig Tsho GLOF of 4 August 1985 was triggered by an ice avalanche from the Langmoche Glacier which induced a dynamic wave on the lake. Vuichard and Zimmerman (1987) reported that an ice mass of 100,000 to 200,000 m<sup>3</sup> dislodged itself from the overhanging glacier tongue and plunged into the lake causing the moraine dam to breach. According to the report, the flood began in the early afternoon and lasted for 4–6 hours. By reconstructing the hydrograph, Vuichard and Zimmerman estimated that the peak flood had been 1,600 m<sup>3</sup>/s; Cenderelli and Wohl (2001) estimated a higher peak discharge of 2,350 m<sup>3</sup>/s. Local witnesses reported that the flood surge moved rather slowly down the valley as a huge black mass of water and debris. The mean velocity of the surge front was between 4 and 5 m<sup>3</sup>/s. The most significant impact of the GLOF was the complete destruction of the newly-built hydropower station in Thame, which had cost an estimated USD 1.5 million.

Source: Bajracharya et al. 2007

### Box 5: Collapse of Gouhou Reservoir, China, 27 August 1993

At 23:40 on 27 August 1993, the Gouhou Reservoir dam in Qinghai Province (total capacity 3.3 × 10<sup>6</sup> m<sup>3</sup>) collapsed and the water in the reservoir flooded out. The maximum flow rate at the dam was 3,000 m<sup>3</sup>/s. Some 2.68 × 10<sup>6</sup> m<sup>3</sup> of water was released. The flood rushed into Qiabuqia Town, 13 km downstream, with a population of about 30,000. More than 1,000 houses were destroyed instantly, 288 people died, and more than 1,000 were injured. The direct economic loss was around USD 27.7 million (RMB 160 million). The collapse was not due to any extraordinary storm or flood but took place in fair weather.

Source: Zhou and Wan 2005



## Non-structural measures

Non-structural measures refer to any measure that does not involve physical construction but instead uses knowledge, practices, and/or agreements to reduce the potential impacts of a flood. Non-structural approaches can be a cost-effective alternative to traditional engineering solutions. Typical approaches include policies and laws, raising public awareness, and training and education. Such measures offer a variety of possibilities including the installation of early warning systems, soil management and acquisition policies, insurance, perception, awareness, and public information actions, emergency systems, and post-catastrophe recovery, all of which can help mitigate flood-related problems. Non-structural measures are generally more sustainable and less expensive than structural measures. They can be the most effective way of managing flash floods, which are often localized and difficult to predict, in contrast to riverine floods. However, non-structural measures are only efficient with the participation of a responsive population and an organized institutional network. Non-structural measures for management of flash flood risk are discussed in detail in Module 2 of this Resource Manual (Shrestha 2008).

## Structural measures

Structural measures refer to any physical construction designed to intervene, control, or mitigate the potential impacts of floods. In other words, they refer to the use of engineering techniques to achieve hazard resistant and resilient structures or systems. They include measures to increase infiltration and reduce rates of runoff in upper catchment areas, measures to stabilize slopes and reduce the likelihood of landslides and mudflows, and structures designed to keep floodwaters away from people and property, such as dams, levees, diversions, and check dams.

Structural measures for flash flood management can be separated into four broad groups in terms of the overall focus (APFM 2007): activities in the whole of a catchment area, activities to shape retention, regulating rivers and streams, and river conservation. Activities in the whole of a catchment area focus on measures to limit the speed of surface runoff and limit flood erosion, including the promotion of good farming practices, terracing, and stabilizing slopes and drainage ditches. Water retention activities can help reduce the flood wave by reducing the amount of water that runs off a catchment surface. Activities to promote retention include constructing small reservoirs, dry reservoirs, and polders and building small dikes and dams. Rivers and streams can be regulated by measures to slow the speed of water flow, including reducing the slope of the riverbed to check erosion, constructing barriers and thresholds, and building different types of anti-debris dams, dikes, and embankments. Finally, in the river valley, the river corridor can be shaped by controlling the depth and slope of the river bed so that flood water is directed away from high impact areas.

Bioengineering is a way of using living plant material to provide reinforcement and create guiding structures. Bioengineering methods are not structural methods in the strict sense of the term as structural methods are usually considered to refer to physical or artificial construction. However, bioengineering techniques are closely related to the physical structural approach, and are often used in combination with and complementary to structural measures. Thus bioengineering methods have also been included in this volume on structural measures.

## The Resource Manual

The present volume focuses specifically on the structural measures that can be used to manage risk from flash floods. In order to design appropriate structural measures, it is first necessary to understand the mechanisms of the major contributing factors so that these can be addressed. Thus the next two chapters are devoted to an understanding of the development and characteristics of landslides and debris flows (Chapter 2) and of landslide dam lakes and glacial lakes (Chapter 3). These, together with intense runoff, are the major causes of flash floods in the Hindu Kush Himalayan mountains. The following three chapters describe various techniques for structural measures that can be used to reduce flash flood risk. These have been divided into three major groups: bioengineering or vegetative measures (Chapter 4); physical measures for slope stabilization and erosion control (Chapter 5); and river training structures (Chapter 6). The final chapter (Chapter 7) looks at the whole approach of integrated water resource (and flood) management in terms of implementing structural measures.

# Chapter 2: Landslides and Debris Flows

Landslides and debris flows are among the major causes of flash floods in the Himalayan region as the rock, earth, debris, and mud that they transport can be deposited across river beds to form an unstable barrier to river flow – a landslide dam – which may fail catastrophically leading to sudden downstream flooding. It is easy for landslide dam lakes to form in the steep and narrow valleys found in high rugged mountain areas because only a relatively small amount of material is needed to block such valleys (ICIMOD 1991a). Thus one way of mitigating flash floods is to take measures to reduce the occurrence of landslides and debris flows. For this, it is first necessary to understand how they form.

## What is a Landslide?

A landslide is defined as the movement of a mass of rock, earth, or debris down a slope (Cruden 1991). A debris flow is effectively a type of landslide in which the mass is saturated or oversaturated with water, thus forming a slurry which flows down the slope. A debris flow is actually an intermediate form between a landslide and a sediment laden flood, with the characteristics of mixed loose solid material (Wu and Li 2001). Debris flows are differentiated from floods by the higher unit weight of flow ( $> 1.3 \text{ tonnes/m}^3$ ) and gradient ( $> 1\%$ ).

## Classification of landslides

Landslides are classified in many different ways. Varnes' (1978) classification is one of the most commonly used; it is based mainly on the nature of the source materials and the type of movement involved. The main types of landslide are summarized in Table 1, illustrated in Figure 1, and described briefly in the following section.

**Fall.** A fall is a sudden movement of material that detaches from a steep slope or cliff. It occurs as a single free fall or a series of leaps and bounds down the slope. Depending on the material involved, it can be a rock fall, soil fall, debris fall, earth fall, boulder fall, or other fall. Falls take place on slopes of  $45^\circ$  to  $90^\circ$ .

**Topple.** A topple occurs when a block of rock tilts and rotates forward on a pivot or hinge point and separates from the main mass or surface, falling to the slope below and subsequently bouncing or rolling down the slope. A topple can be triggered by gravity, water, ice, or wind, and the rate of topple can vary from very slow to extremely rapid.

**Table 1: Types of landslide (abbreviated classification of slope movements)**

Type of movement	Type of material		
	Engineering soil		Bedrock
	Predominantly fine	Predominantly coarse	
Fall	Earth fall	Debris fall	Rock fall
Topple	Earth topple	Debris topple	Rock topple
Slide (rotational/translational)	Earth slide	Debris slide	Rock slide
Lateral spread	Earth spread	Debris spread	Rock spread
Flow	Earth flow	Debris flow	Rock flow
Complex	Combination of two or more principal types of movement		

Source: abbreviated version of Varnes' classification (Varnes 1978)

Figure 1: Types of landslide

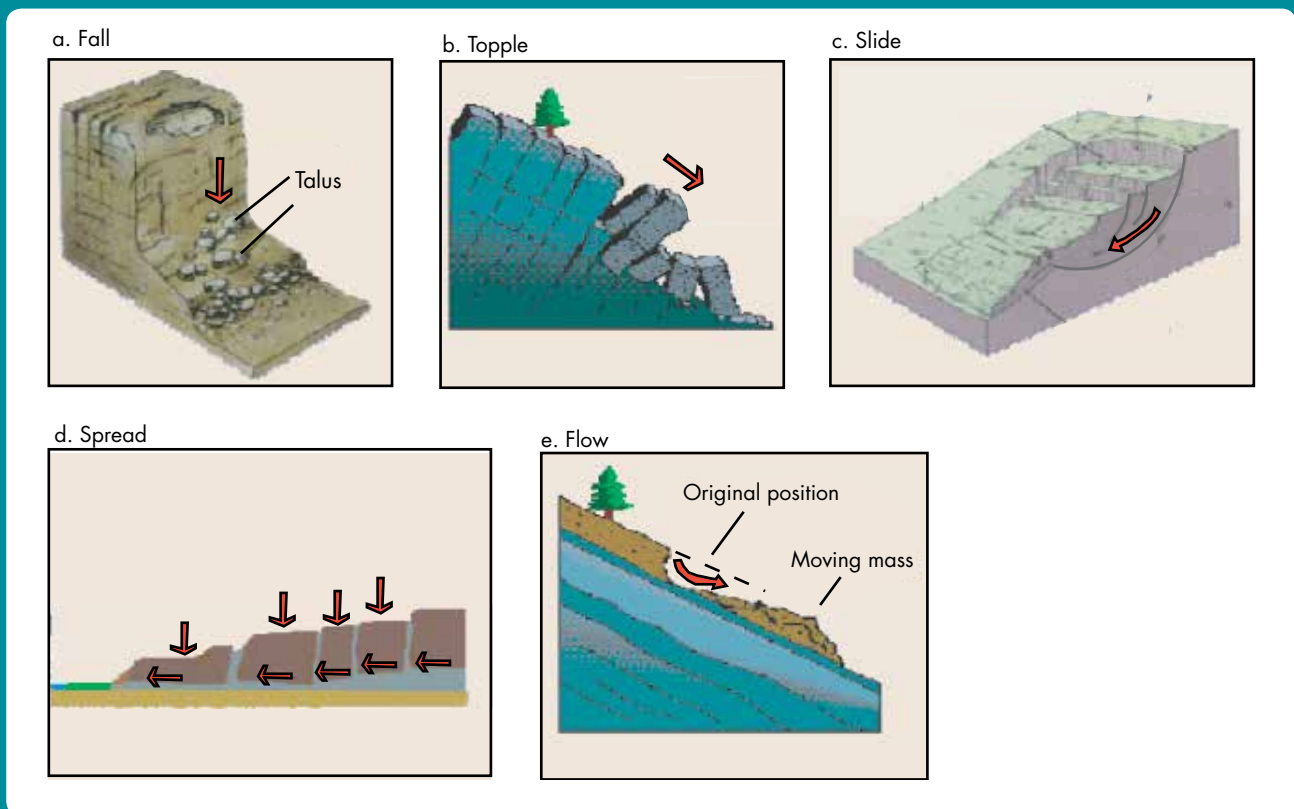

**Slide.** A slide is a down slope movement of rocks or soil occurring mainly on surfaces of rupture or relatively thin zones of intense shear strain. There are two major types of slide: rotational and translational. Rotational slides occur most frequently on the surface of homogeneous slopes, whereas translational slides take place on more or less plane surfaces.

**Spread.** A spread is an extension of a cohesive soil or rock mass combined with a general subsidence of the fractured mass of cohesive material into softer underlying material (Cruden and Varnes 1996). It occurs when a large block of soil spreads out horizontally after fracturing from the original base. Spreads usually occur on gentle slopes of less than  $6^\circ$ .

**Flow.** A flow is in effect a liquefied landslide containing a high proportion of unconsolidated, saturated material suspended in water. Flows can carry material ranging in size from clay to boulders, and may contain woody and plant debris such as logs and tree stumps. Flows can be of different types according to the materials they contain and the speed of flow, including mudflows, earth flows, debris flows, creeps, and debris avalanches. The rate of flow may vary from slow to very rapid (from 5 km/hr to 40–50 km/hr or more in extreme cases) and the flow can cover several kilometres. The flow starts when unconsolidated material becomes saturated and can be triggered by intense rainfall, glacial melt, and earthquakes and precipitated by shallow landslides or in some cases by the collapse of a riverbed. Debris flows are relatively common in steep mountain areas with high rainfall. They are extremely destructive of life and property because of the mass and high speed of flow (Takahashi 2007). They can cause significant erosion of the substrates over which they flow, thereby increasing their sediment charge and further increasing their erosive capabilities (Nettleton et al. 2005).

**Complex movement.** A complex movement is a combined process of two or more of the types of movement mentioned above. Large-scale movements are usually complex, as in a rock/debris avalanche, for example.

## Mechanism of Landslide Formation

A landslide is a by-product of slope instability. Slope stability is the state of balance between driving forces and resisting forces acting on the earth's surface (Figure 2). The driving force tends to pull materials down a slope whereas the resisting force holds the material where it is. When the driving force exceeds the resisting force, the slope becomes unstable and the materials on the slope will start to move. This can result from an increase in the driving force, a decrease in the resisting force, or a combination of the two.

### Driving force (shear stress)

The driving forces on a slope make up the shear stress or driving stress ( $\tau$ ). The main force contributing to shear stress is gravity. The slope angle, type of material, water content, earthquakes, and anthropogenic activities can all contribute to the effect of gravity. The driving force increases with increasing steepness.

### Resisting force (shear strength)

The resisting forces on a slope make up the shear strength ( $S$ ). These forces develop as a result of the internal friction caused by interlocking of molecular particles. The resisting forces depend upon the shear strength of the slope materials, which is a function of cohesion and internal friction (shear strength = cohesion + internal friction). Cohesion ( $C$ ) is the innate 'stickiness' of a material: the strength of attraction or bonding of molecules. For example, clay and granite are both cohesive whereas dry sand is non-cohesive. Internal friction refers to the friction between grains within a material and is expressed in terms of the coefficient of friction or angle of internal friction ( $\phi$ ). It depends on how slick the grains are and is a function of the type of material and how strongly the grains are pressed together by gravity, which is expressed in terms of the slope normal component of gravity or normal stress ( $\sigma$ ). Water plays an important role in reducing the resisting force.

The forces acting on a point along the potential failure plane are illustrated in Figure 3.

### Factor of safety

The factor of safety,  $FS$ , for a rock slope is the ratio of the total force resisting sliding (resisting forces) to the total force tending to induce sliding (driving forces) (Li et al. 2001) along an assumed or known rupture surface. In other words, it is the ratio between the shear strength and the shear stress:

$$FS = \frac{\text{Shear strength (resisting force)}}{\text{Shear stress (driving force)}}$$

$FS < 1$  indicates unstable slope conditions,  $FS = 1$  indicates that the slope is at the point of failure, and

Figure 2: Forces acting on a slope

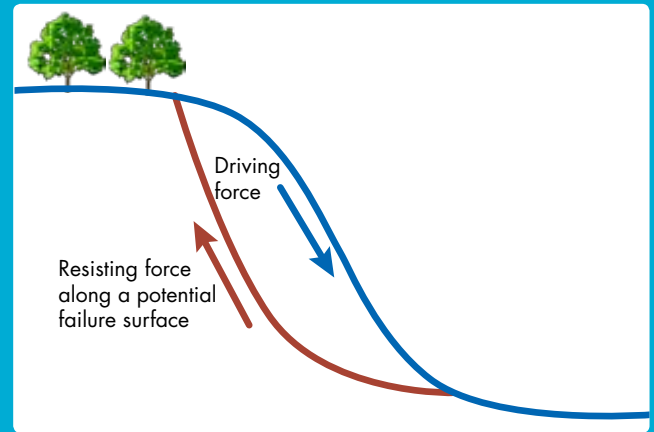
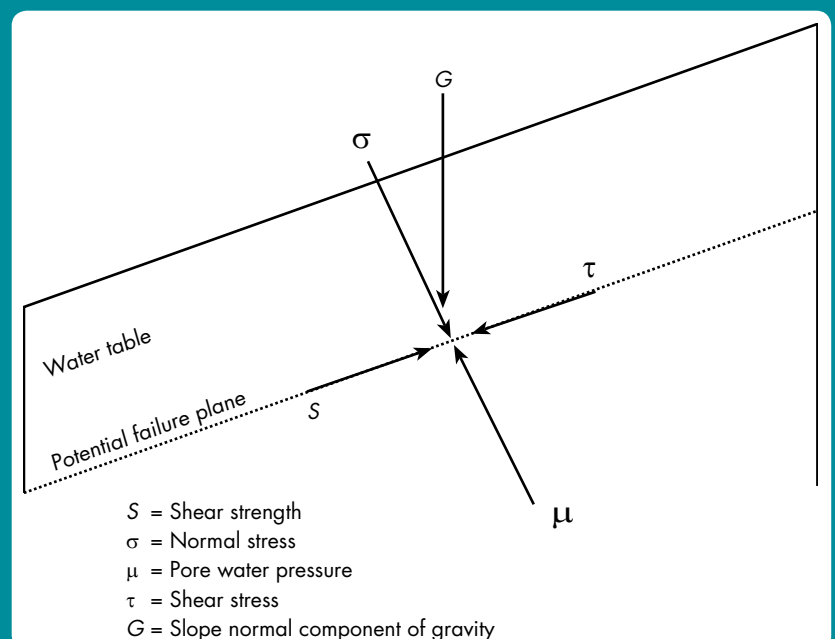

Figure 3: Force diagram for thin to thick translational slides



$FS > 1$  indicates stable slope conditions. According to Vazirani and Ratwani (1980) the factor of safety against sliding should be not less than 1.5.

In order to assess the potential of failure on a slope, it is important to calculate the factor of safety.

The equation for the factor of safety is given by

$$FS = \frac{C + (\gamma - m\gamma_w) z \cos \beta \tan \phi}{\gamma z \sin \beta}$$

where

$C$  = the cohesion of the material,

$\gamma$  = the unit weight of the material,

$m$  = the proportion of the slab thickness that is saturated,

$\gamma_w$  = the unit weight of water,

$z$  = the thickness of the slope material above the slide plane,

$\beta$  = the slope of the ground surface in degrees assumed to be parallel to the failure plane, and

$\phi$  = the internal angle of friction in degrees.

The model relies on several simplifying assumptions. The values take into account factors such as the level of the water table, the depth of the failure surface, and soil weight but do not account for the impact of adjacent factors such as upslope development or downslope modifications of the hill slope or accentuating factors such as ground vibrations or acceleration due to earthquakes.

The shearing resistance of a soil can also be determined in the laboratory using the direct shear test, triaxial shear test, unconfined compression test, or Vane shear test.

## Factors Contributing to the Development of Landslides

A landslide is the result of slope failure. The causative and triggering factors include anything that leads to an increase in the shear stress (driving force) on the slope, a decrease in the shear strength (resisting force), or a combination of the two. The factors can be geological, morphological, physical, and/or human (Cruden and Varnes 1996). They are generally divided into natural factors and man-made (anthropogenic) factors. The major natural factors include high relief and steep slopes, soil type, vegetation cover, river bank erosion, heavy precipitation, earthquakes, folding and faulting, and weathering. In particular, unconsolidated deposits, strongly weathered and fractured rocks, and earth become saturated during heavy rainstorms and are then very prone to slide on a steep slope. The major anthropogenic factors are inappropriate land use and poor watershed management practices such as deforestation, extension of agriculture on steep slopes, intensive agriculture or unsuitable crops, and overgrazing; poor water management; unplanned settlements; and poorly planned construction of roads, trails, and other infrastructure.

Debris flows are characterized by high water content. The causative factors for debris flows include the above, but of these the most important are steep slope, loose rock and soil materials, clay minerals, saturated soils, and especially rainfall or snowmelt generated runoff of sufficient intensity and duration to initiate slope movements (Brooks et al. 2005; Tognacca et al. 2000, cited in Brien et al. 2008).

## Mitigation Measures

The first approach to mitigating flash floods is to reduce the likelihood of occurrence of landslides and debris flows, and thus the creation of landslide dams. This means taking measures to reduce the likelihood of slope failure. Slope failure mitigation measures can be divided into three categories: control, restraint, and other (JICA 2006). The most common measures are summarized in Table 2 and discussed briefly below. Specific techniques are described in detail in Chapter 4 (Bioengineering Measures) and Chapter 5 (Physical Methods).

## Control measures

Control measures are applied to prevent or reduce the occurrence of landslides by modifying the natural conditions that contribute to their formation such as topography, groundwater, surface water, and other conditions. These measures can be implemented gradually over a long period. The major types of control measure are drainage, slope protection, and reforming the slope through soil removal.

Increasing the efficiency of surface water drainage can help to limit the infiltration of water into the soil and thus reduce the landslide potential. The two main approaches are drainage collection and drainage connection to remove the collected water. It can also be useful to limit water entering the ground from water bodies such as ponds, irrigation channels, and paddy fields by making the banks and bottom of these water bodies water resistant or impermeable with materials such as plastic sheeting, clay, asphalt, and concrete.

Groundwater control measures are designed to remove groundwater from the slope and prevent more water flowing into the mass from outside. This can mean draining surface water and shallow sub-surface water up to 3 m below the surface as well as draining water from deeper layers by boring. Where the slip surface is in the shape of a valley, drainage wells can be dug at the bottom of the valley and water can be drained out to the wells through a borehole. A drainage tunnel can be built to remove deep underground water, where a large volume of underground water flows near the slip surface.

Slope protection measures involve using vegetation (bioengineering) or artificial structures to stabilize the slope and cover the surface to reduce infiltration and increase cohesion. Bioengineering methods are one of the main approaches used to mitigate debris flows, as minimizing runoff above the slope and binding loose materials on the slope through a network of roots have the highest priority. Bare slopes without vegetation are more prone to debris flows than slopes covered by vegetation (Li and Clarke 2007).

The slope can also be reformed to maintain the balance of the landmass, most commonly by removing the sliding mass from the upper part, sometimes replacing it at the foot of the slope. Such measures require skilled engineering and can sometimes trigger a landslide, so careful investigation and planning is required before implementation.

**Table 2: Mitigation measures**

Purpose	Drainage	Surface drainage/groundwater drainage	
Control	Slope protection with vegetation	Bioengineering	
	Slope protection using structures	Spraying	Spraying mortar Spraying concrete
		Plastering	Plastering with stones or blocks Spraying concrete
		Crib work	Pre-cast crib wall construction Cast-in-place crib work
	Removal of unstable soil mass	Excavation	
Restraint	Improvement of slope shape	Excavation	
	Construction of retaining walls	Stacked blocks and stone masonry Concrete leaning walls Concrete gravity walls Concrete crib retaining walls	
	Pile construction	Piling	
	Anchoring	Anchoring	
	Counterweight filling	Counterweight filling	
Other	Protection methods	Catch walls	
	Rock fall prevention	Rock fall prevention measures Rock fall check measures	
	Avalanche control	Avalanche trapping measures	
	Other construction	Fencing Installing gabions Temporary protection measures	

Source: DWIDP/JICA 2004b

## Restraint measures

Restraint measures are structural ways of reducing the likelihood of landslides. The most common measures are construction of retaining walls, anchoring, and pile construction. These techniques have high construction costs and require specific technical skills; careful investigation and understanding is needed before designing such measures.

Retaining walls can be installed to hinder the small or secondary landslides that often occur at the toe of larger landslides. Retaining walls are effective against small landslides but cannot resist direct landslide driving forces. They are usually installed in combination with other measures such as bases of embankment structures and walls for drainage of horizontal borings. Different types of walls are discussed in more detail in Chapter 5.

Anchors use the tensile force of anchor bodies to stabilize the slope. Steel wires or bars are inserted throughout the sliding landmass and cemented into the bedrock in order to join the sliding landmass and bedrock together. Anchor work can be used on moderate to steep slopes. The advantage of anchors is that a large restraint force can be obtained from a relatively small element. Large restraint forces can be obtained by increasing the number of anchors.

Steel piles can be used in a similar way as anchors to tie the sliding landmass to the bedrock below in order to restrain movement. Steel piles of 200–600 mm diameter are designed to resist both shearing and bending stress. Piles are generally filled with concrete.

The lowest, or toe, area of a landside can be prevented from moving by piling up extra material, and slope stability can be increased by reducing erosion at the toe. This method is widely implemented because of its reliability and immediate effect and is sometimes combined with soil removal from the upper part.

## Other measures

Other protection measures include installing catch walls on lower slopes to slow landslides, measures to prevent rock falls that might trigger a landslide, and various types of fencing and other measures to protect installations from the impact of landslides. These measures also include sabo dams, which are designed to reduce the load carried downstream by a debris flow. Sabo dams are discussed in more detail in Chapter 5.



# Chapter 3: Landslide Dam Lakes and Glacial Lakes

The triggers of flash floods in the Hindu Kush Himalayas include catastrophic failure of landslide dams that retain landslide dam lakes, and of moraine or ice dams that retain glacial lakes. Flash flooding caused by landslide dam failure is a significant hazard in the region and is particularly common in the high rugged mountain areas of China, India, Nepal, and Pakistan (Zhu and Li 2000). The previous chapter looked at ways of preventing the formation of landslide dams by reducing the prevalence of landslides and debris flows. Another important approach to mitigating flash floods is to reduce the likelihood of dam failure, and/or to put in place warning and avoidance mechanisms to reduce the risk in the case of failure. In order to design appropriate measures, it is important first to understand the formation process, failure mechanism, and risk mitigation techniques for both types of lake.

## Landslide Dam Lakes

### Formation

Landslide dam lakes can be created as a result of a broad range of mass movements in different geomorphological settings. Dams form most frequently as a result of rock and earth slumps and slides, debris and mudflows, and rock and debris avalanches in areas where narrow river valleys are bordered by steep and rugged mountain slopes (Zhu and Li 2000). A lake then forms behind the dam as a result of the continuous inflow of water from the river (Figure 4). Only a small amount of material is needed to form a dam in a narrow valley, and even a small mass movement can be sufficient. This type of setting is common in geologically active areas such as the Hindu Kush Himalayas where earthquakes occur and slopes are steep. These areas contain abundant landslide source materials such as sheared and fractured bedrock materials. Large landslide dams are often caused by complex landslides that start as slumps and transform into rock or debris flows or avalanches. The lake formed along the Hunza River by a massive landslide in Attabad, Pakistan, in January 2010 is one of the more striking recent examples of a landslide dam lake in the region.

### Landslide dam outburst floods (LDOF) and modes of dam failure

A dam failure is a complex hydrologic, hydraulic, and geological phenomenon which is controlled primarily by the failure mechanism and characteristics and properties of the dam (Uhlir 1998). In many cases, the breach occurs as a result of fluvial erosion of the debris or landslide material, with erosion starting at the toe of the dam and moving progressively upstream to the lake. Piping (the presence of sloping tube-like features in the soil often marked by seepage) can also lead to internal structural failure of the dam. However, the most common cause of failure is overtopping by the lake water. Sometimes, piping and undermining of the dam can cause partial collapse followed by overtopping and breaching. A landslide dam with steep upstream and downstream faces and high pore-water pressure is also susceptible to slope failure. If the dam has a narrow cross-section or the slope failure is progressive, the crest of the dam can fail, again leading to overtopping and breaching. Sometimes, lateral erosion of the dam by the stream or river can cause failure.

### LDOF risk mitigation measures

Both structural and non-structural measures can be used to reduce the risk associated with landslide dam failure.

Non-structural measures (discussed in Module 2) include estimation of downstream flooding, estimation of past floods, early warning systems, and so on.

Figure 4: Formation of a landslide dam lake

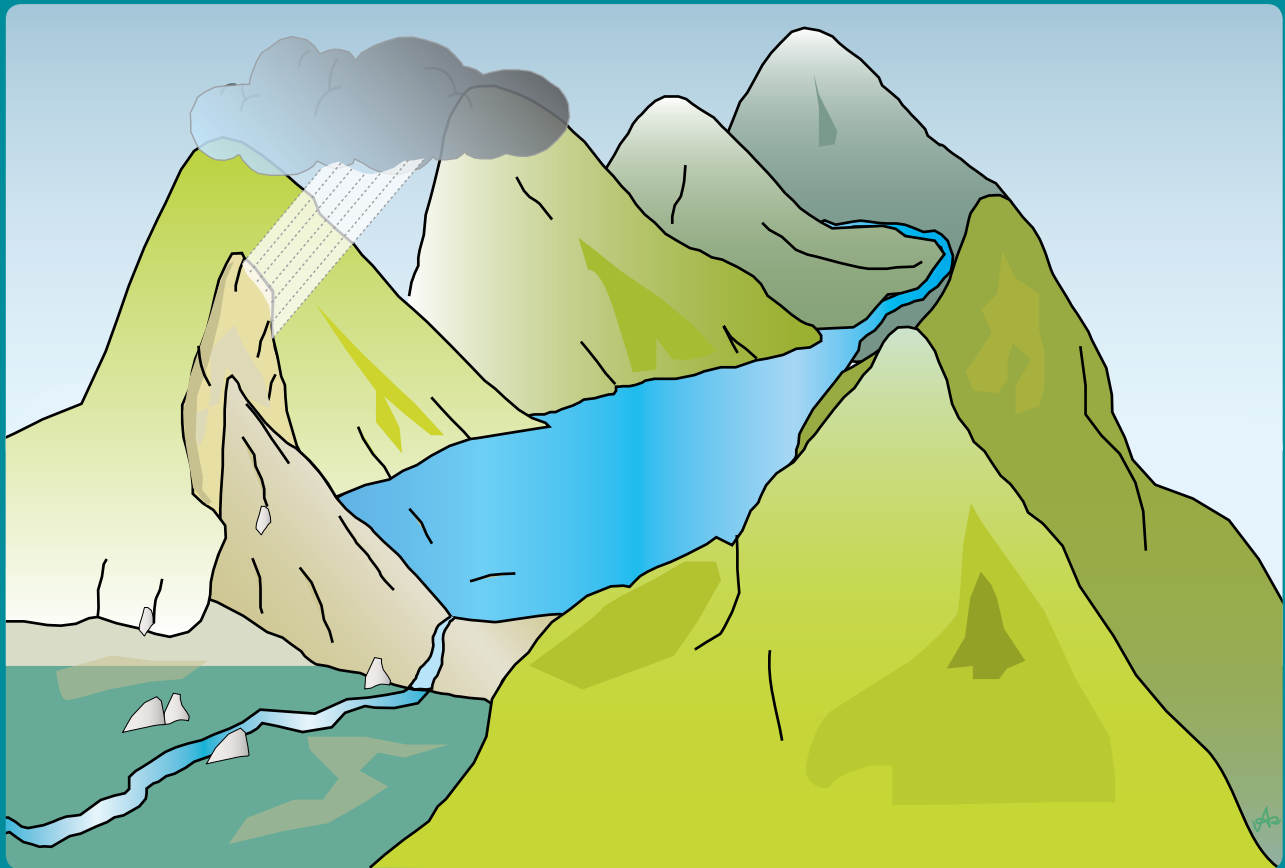

One of the most efficient structural measures is to lower the water level of the lake. Construction of spillways is the simplest approach. Pipes, tunnels, outlets, and diversions can also be used to control discharge (Zhu and Li 2000) and help drain the water. For example, Tangjianshan Lake, formed as a result of a landslide precipitated by the 12 May 2008 Wenchuan earthquake in China, was successfully drained by construction of a sluiceway 13 m wide, 10 m deep, and 475 m long (Zhuang 2010). In some cases, extensive blasting measures have been used to excavate new river channels through landslide dams (Zhu and Li 2000). However, it is not always possible to construct a drainage path, the unstable nature of the dam material can lead to collapse of the channel, and, in the worst cases, the channel construction itself can destabilize the dam and cause it to breach catastrophically.

## Glacial Lakes

### Formation

The ways in which glacial lakes can form and their distribution in the Hindu Kush Himalayan region are described in some detail in Ives et al. (2010) and ICIMOD (2011). They can be divided into two broad categories on the basis of the damming materials: moraine-dammed glacial lakes and ice-dammed glacial lakes. Moraine-dammed lakes usually form between the glacier terminus and the exposed end moraine as a glacier tongue thins and retreats (Figure 5). Ice-dammed lakes can form on the surface of a glacier and between a glacier and valley wall. Lakes can also form below or within glaciers but these are difficult to identify using normal mapping approaches and in practice no mitigation measures are possible.

### Glacial lake outburst floods (GLOF) and modes of dam failure

Moraine dams are composed of unconsolidated boulders, gravel, silt, and sand and are thus often weak and susceptible to collapse. As glaciers retreat, the volume (and thus weight) of the water in the lake increases,

Figure 5: Formation of glacial lakes: lateral moraine dammed lake with ice (left) and end moraine dammed lake (right)

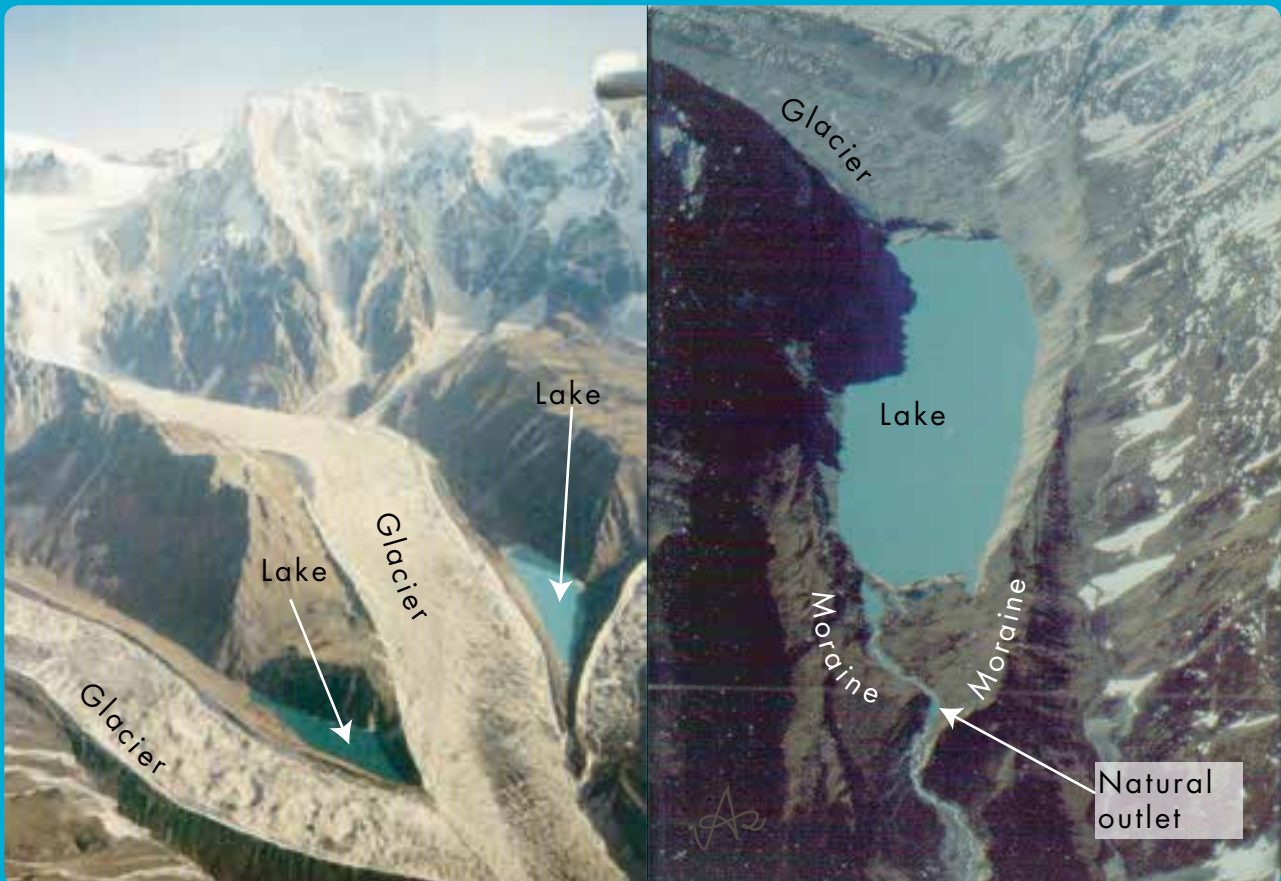

increasing the pressure on the dam. Moraine dammed lakes generally breach as a result of overtopping or piping, or a combination of the two (Mool 1995). Overtopping can be precipitated by a fall of ice (or rock) into the lake water, or by a sudden inflow of water from an outburst of a small lake higher up.

Ice-dammed lakes drain underneath the ice. On occasion a pocket of water can burst within the ice. Water within the glacier's internal plumbing may build up pressure to such a point that the hydrostatic pressure exceeds the constraining cryostatic pressure and the water is able to rupture through the glacier ice. Internal water pockets may burst into existing sub-glacier draining, increasing the discharge to produce a characteristic flow (Sinha 1998).

In 1994, a catastrophic flood from the moraine dammed Luggye Tsho glacial lake in northern Bhutan produced a flood wave that was more than 2 m high at 200 km from the source (Richardson and Reynolds 2000).

### GLOF risk mitigation measures

As with landslide dams, both structural and non-structural measures can be used to reduce the risk associated with moraine dam failure. The biggest difference is that glacial lakes can be identified and the risk assessed in a planned way, as the glaciers and moraines have a fixed position, unlike landslide dams which are unpredictable. Thus more time is available to plan and implement measures to reduce the likelihood of moraine dam failure. The approaches to and difficulties of GLOF risk assessment in the Hindu Kush Himalayan region are discussed in Ives et al. (2010).

Non-structural measures are discussed in Module 2 and Shrestha et al. (2011). They include risk assessment; planning measures that reduce exposure and vulnerability; awareness raising and flood preparedness training; and lake monitoring, early warning, and evacuation.

Structural measures aim to reduce the volume of water in the lake in order to reduce the potential peak discharge as well as the hydrostatic pressure on the dam. The four main approaches – controlled breaching of the moraine

dam, construction of an outlet control structure, pumping or siphoning the water from the lake, and tunnelling under the moraine or ice dam (Ives et al. 2010; Kattelmann and Watanabe 1996) – are described briefly below. The challenge with all the approaches is that the moraine dam is inherently unstable, and disturbance of the dam during construction could itself precipitate collapse. At the same time, construction at the altitudes where glacial lakes are found is challenging, as is transportation of the appropriate equipment to these often very remote and poorly accessible sites. A high degree of technical and engineering skill is required, and investigation and planning must be meticulous. For this reason, structural mitigation is only an option for a very small number of lakes.

**Blasting.** If glacial lakes are at an early stage in formation and the water volume is small, it may be possible to blast the dam. However, careful precautions must be taken, in particular, total evacuation of the downstream area before blasting.

**Construction of a spillway or open channel.** Construction of a spillway or open channel is one of the most common techniques used to lower the water level in glacial lakes. However, the risk of rapid erosion of the spillway and uncontrolled release of water is substantial (Grabs and Hanisch 1993, cited in Kattelmann and Watanabe 1996). An artificial spillway has been used to lower the level of Tsho Rolpa glacial lake in Nepal since 2000. Precise engineering efforts are needed to implement such types of technique.

#### Box 6: Siphoning out Tsho Rolpa glacial lake

The purpose of installing siphon pipes was to test their performance in the high altitude environment with freezing conditions in winter. The test siphons worked satisfactorily with some maintenance, although the amount siphoned out was insufficient. The test showed that with sufficient funds, siphoning could be an option for lowering the water level (Rana et al. 2000).

**Siphoning.** Siphoning out the lake water has a lower risk of inducing catastrophic failure and is more appropriate for remote areas. In theory, lake levels could be lowered by as much as five metres with a simple siphon under Himalayan conditions (Grabs and Hanisch 1993, cited in Kattelmann and Watanabe 1996). The number of siphons could be chosen to give the desired rate of lowering of the water level, taking into account the rate of inflow during the summer monsoon and melt seasons (Kattelmann and Watanabe 1996). Siphons were installed successfully in Tsho Rolpa lake in 1995, but

the induced outflow never reached a level that exceeded the inflow, so ultimately the effort was unsuccessful (Box 6). However, siphoning might still offer a useful option under different conditions.

**Drilling and tunnelling.** Another possibility is to drill or tunnel through the moraine dam and install a pipe to drain the water from the lake. Drilling is problematic, however, due to the inhomogeneous and poorly consolidated structure of the dam material and the risk of piping occurring along the casing installed during drilling (Grabs and Hanisch 1993). Another option for releasing lake water is to construct a tunnel into the lake from an adjacent deeper lying valley. Tunnels have been built through solid rock into glacial lakes in Norway and Switzerland (Kattelmann and Watanabe 1996), but the approach is impractical in the Himalayas with their weak geological structure and remoteness.

# Chapter 4: Bioengineering Measures

Bioengineering is the application of engineering design and technology to living systems. In terms of flash flood mitigation, it refers to the combination of biological, mechanical, and ecological concepts to reduce or control erosion, protect soil, and stabilize slopes using vegetation or a combination of vegetation and construction materials (Allen and Leech 1997; Bentrup and Hoag 1998) (Figure 6).

Bioengineering techniques used in combination with civil and social engineering measures can reduce the overall cost of landslide mitigation considerably (Singh 2010). Bioengineering offers an environmentally friendly and highly cost and time effective solution to slope instability problems in mountainous and hilly areas and is a technique of choice to control soil erosion, slope failure, landslides, and debris flows, and thus ultimately to help minimize the occurrence of floods and flash floods.

One of the major differences between physical construction techniques and bioengineering is that physical structures provide immediate protection, whereas vegetation needs time to reach maximum strength. Thus the combination of physical and vegetative measures offers a combination of immediate and long-term protection, as well as mitigation of the ecologically damaging effects of some physical constructions.

## Functions of Vegetation

### Hydrological functions

Plants play a significant role in the hydrological cycle. Particularly riparian vegetation influences hydrological processes through effects on runoff; control of uptake, storage, and return of water to the atmosphere; and water quality (Tabacchi et al. 2000). The hydrological functions of vegetation can be summarized as follows:

- **Interception:** The vegetation canopy intercepts raindrops and reduces their size and mechanical strength, thus protecting the soil from erosion caused by rain splash.
- **Restraint:** The dense network of coarse and fine roots physically binds and restrains soil particles in the ground, while the above ground portions filter sediment out of runoff.
- **Absorption:** Roots absorb surface water and underground water thus reducing the saturation level of soil and the concomitant risk of slope failure.
- **Infiltration:** Plants and their residues help to maintain soil porosity and permeability, thereby increasing retention and delaying the onset of runoff.
- **Evapotranspiration:** Vegetation transpires water absorbed through the roots and allows it to evaporate into the air at the plant surface.
- **Surface runoff reduction:** Stems and roots can reduce the velocity of surface runoff by increasing surface roughness.

Figure 6: Bioengineering for soil conservation



Source: DWIDP



- **Stem flow:** A portion of rainwater is intercepted by trees and bushes and flows along the branches and stems to the ground at low velocity. Some rainwater is stored in the canopy and stems.

## Engineering functions

- **Catching:** Loose materials have a tendency to roll down a slope because of gravity and erosion, and this can be controlled by planting vegetation. The stems and roots can catch and hold loose material.
- **Armouring:** Some slopes are very water sensitive. They start moving and/or are easily liquefied when water falls on them. Vegetation can protect the surface from water infiltration and erosion by rain splash.
- **Reinforcing:** The shear strength of the soil can be increased by planting vegetation. The roots bind the grains of soil. The level of reinforcement depends on the nature of the roots.
- **Supporting:** Lateral earth pressure causes a lateral and outward movement of slope materials. Large and mature plants can provide support and prevent movement.
- **Anchoring:** Layers with a tendency to slip over each other can be pinned to each other and the stable underlying layer by penetration of woody taproots from vegetation which function as anchors.
- **Draining:** Water is the most common triggering factor for slope instability. Surface water drains away more easily in areas with dense rooted vegetation. Thus draining can be managed by planting small and dense rooted vegetation such as durva grass.

## Choice of appropriate species

In general, it is best to use local species of vegetation in bioengineering as they are already adapted to the growing conditions, are more likely to be resistant to local diseases, are more readily available, and are likely to be a lower cost option.

It can also be useful to choose species that can be used for other purposes as they mature, for example, providing fruit or with branches and leaves that can be used for fuelwood, fodder, or other domestic purposes. This increases the benefit to local people and their acceptance of the measures.

Major species that can be used for bioengineering purposes in the Hindu Kush Himalayan region include broom grass (*Thysanolaena maxima*), Napier grass (*Pennisetum purpureum*), vetiver grass (*Vetiver zizanioides*), durva grass (*Cynodon dactylon*), turf grass (e.g., *Festuca arundinacea*, *Poa pratensis*), kans grass (*Saccharum spontaneum*), different types of bamboo, giant cane (*Arundo donax*), Malabar nut (*Adhatoda vasica*), male fern (*Dryopteris filix-mas*), artemesia (*Artemisia* spp.), weeping willow (*Salix babylonica*), mulberry (*Morus alba*), five-leaved chaste tree (*Vitex negundo*), ghogar tree (*Garuga pinnata*), coral tree (*Erythrina variegata*), tiger's milk spruce (*Sapium insigne*), and eastern cottonwood (*Populus deltoides*). Further suitable grass, shrub, tree, and bamboo species can be found in Singh et al. (1983), APROSC (1991), HMGN (1999), DSCWM (2004), and DSCWM (2005).

## Bioengineering in Flash Flood Risk Management

Bioengineering can be used in various ways to reduce flash flood risk. It can be used to stabilize slopes and thus reduce the risk of landslides and debris flows occurring. It can be used to increase infiltration, to form structures to temporarily capture and store runoff, and to lower the velocity of runoff, all of which hinder the formation of flash floods after cloudbursts. And it can be used to change the flow pattern of rivers downstream in order to reduce the impact of floods that do occur. Bioengineering is often used in combination with structural techniques, either to reinforce structures or as a complementary approach to increase the overall impact of the measures.

### Bioengineering techniques to control slope failure phenomena

Bioengineering can be used to increase slope stability in a variety of ways (Li and Clarke 2007; Lammeranner et al. 2005), in particular

- mechanical reinforcement,
- controlling erosion,
- increasing the infiltration ratio,

- reducing runoff, and
- soil moisture adjustment.

**Reinforcement.** The dense network of coarse and fine roots from vegetation can work as a reinforcement mechanism on the slope by binding and stabilizing loose materials. The stabilizing effect of roots is even greater when roots are able to connect top soil with underlying bedrock, with the root tensile strength acting as an anchor. Small dense roots also contribute to the shear strength of a slope and thus reduce the risk of landslides and debris flows. Trees and bamboos can stabilize the whole soil layer in slope terrain, whereas bush and shrub roots mainly protect soil up to 1 m deep, and grasses can conserve top soil to a depth of around 25 cm (Jha et al. 2000).

**Erosion control.** Bare soil-covered slopes are easily affected by the splash effect of intense rain leading to heavy erosion. The surface runoff rate is also very high, and the flowing water can carry the soil particles away and trigger a debris flow. A dense cover of vegetation protects the soil from splash effects and reduces runoff velocity, while the roots bind the soil particles, thus hindering surface erosion.

**Soil infiltration.** As decayed roots shrink, they leave a gap which provides a passage for water seepage, which leads water away from the surface and reduces the likelihood of surface soil saturation. This reduces slope instability and hinders the development of debris flows.

**Reducing runoff.** Vegetation can be used to reduce runoff in a number of ways including trapping of moisture in leaves and branches, slowing the flow of water across the rough surface, increasing infiltration, and through structures designed to deflect flow away from the top of a slope and channel it along a desired pathway down the slope.

**Soil moisture adjustment.** Soil moisture is a key factor in slope stability. Vegetation can directly influence soil moisture through interception and evapotranspiration. In interception, precipitation is captured by the vegetation canopy and returned directly to the atmosphere through evaporation. The rate of interception varies according to various factors including leaf type and size, canopy density, temperature, and humidity. In evapotranspiration, the plants channel moisture from the soil to the leaves and stems, from where it returns to the air via evaporation. These two processes combine to reduce the overall soil moisture content.

**Choice of techniques.** Different bioengineering techniques are used to control erosion and slope failure in different parts of the world. The techniques suitable for a particular area should be selected on the basis of availability of resources, site condition, and required function. Table 3 shows the appropriate bioengineering techniques for controlling different types of landslide and debris flow hazards. Details of the techniques are given in the latter part of this chapter.

## Bioengineering to reduce the volume and velocity of runoff

High runoff can directly cause development of a flash flood from a small catchment following a heavy localized rainfall event. The aim of bioengineering in this case is to slow and trap the runoff in order to reduce the rate of outflow from the catchment. Appropriate techniques include palisades, grassed water ways, brush layering, bamboo fencing, wattle fencing, and similar measures.

## River training

The impact of a flash flood can be reduced by measures designed to direct and reduce the speed of the flood wave in the river downstream. These measures are a part of so-called 'river training' techniques, which are undertaken to improve a river and its banks in order to change the waterway pattern and reduce the velocity of flow, hinder erosion, reduce transportation of sediment, and guide flood waves into a less destructive path. The most common river training measures involve construction of physical structures such as banks and spurs (described in Chapter 6). However, used alone, these techniques may have a marked negative effect on the environment and landscape, as well as being expensive. Bioengineering techniques used alone or in combination with physical measures offer a low-cost approach that is easily implemented by local communities and provides an environmentally friendly environment for local flora and fauna.



**Table 3: Basic techniques for bioengineering**

Phenomenon	Erosion problem and condition	Suitable bioengineering techniques
Landslide	Deep-rooted landslide (>3 m depth)	Smoothing to a suitable slope gradient Diversion canals, channel lining, catch drains, waterways
	Slumping	Stone pitching and planting of trees, shrubs, and grass slip
	Planar sliding	Bamboo fencing with live poles, planting and seeding grass Terracing and planting with bamboo, trees, shrubs, grass
	Shear failure	Live peg fence, wild shrubs, live check dams Contour strips planted with grass, shrubs, and pegs
	Cut and fill area at deep and shallow-rooted landslide (<3 m depth)	Fascines, brush layering, and palisades Planting bamboo with or without a structure Check dams planted with deep-rooted species (e.g., bamboo, trees)
	Bare and steep slope or newly exposed surface	
	Cracking zone	Bamboo fencing above zone; zone covered with polythene sheet Catch drain with vegetation Fascines, brush layering, and palisades
Debris flow	Head scarp of landslide or slope failure	Slope excavated to an appropriate gradient and rounded (when high and steep) and planted with deep-rooted plants (e.g., bamboo, trees) Bamboo fencing, planting grass, seeding, and mulching Fascines, brush layering, and palisades Jute netting or straw mat covering soil, seeds, and compost mixture; turfing Stone pitching; planting of trees, shrubs, and grass slip Planting grass slip and seeding grass
	Sediment production zone	As for landslides
	Sediment transportation zone	Series of gabion check dams, retaining wall, and side wall planted with deep-rooted species (e.g., bamboo, trees) Bamboo fencing; grass planting, seeding, and mulching
Soil Erosion	Sediment deposition zone	Diversion canal, channel lining, retaining wall, and side wall planted with trees, shrubs, and grasses Plantation of deep-rooted species (e.g., bamboo, trees)
	Sheet and rill erosion	Planting of bamboo, trees, shrubs, and grass with or without terracing Live peg fence, wild shrubs, and live check dams Contour strips planted with grass, shrubs, trees, and pegs Fascines, brush layering, and palisades with wild and thorny shrub species.
	Gully erosion	Diversion canals, channel lining, catch drains, waterways, cascade retaining wall, and side wall, planted with trees, shrubs, and grasses Bamboo fencing with live pegs Planting of bamboo, trees, with or without check dams Series of retaining walls and plantation Vegetated stone pitching in small gullies and rill beds
	Erosion on bare land, degraded steep sloped land, dry and burnt area	Planting of deep-rooted species (e.g., bamboo, trees) Bamboo and live peg fencing and live check dams Vegetated stone pitching in small sheets and rill beds Stone pitching and planting of trees, shrubs, and grass slip
	Degraded shifting cultivation areas, newly excavated or exposed areas on terrace bund, degraded forest, and grazing land	Bamboo fencing with live poles, planting and seeding grass Planting of bamboo, trees, shrubs, and grass with or without terracing and structure Live peg fencing and live check dams Vegetated stone pitching in small gullies and rill beds Contour strips planted with grass, shrubs, trees, and pegs Planting fascines, brush layering, and palisades
	Water induced degraded land (spring, water source damaged area, canal command area)	Planting of bamboo, trees, shrubs, and grass with or without terracing and structure Stone pitching and planting of trees, shrubs, and grass slip Planting of deep-rooted species (e.g., bamboo, trees) Live peg fences and live check dams Vegetated stone pitching and loose stone masonry walls or check dams
	Cut and filled area or newly exposed area on slope*	Jute netting and straw mats covering soil, seeds, and compost Live peg fences and stone masonry walls Plantation, seeding, and planting grass Live wattling with terracing and seeding

\*Exposed slope surfaces must be carefully maintained. A cut and newly exposed slope surface should usually be covered, depending on the type of soil material and other factors.

Source: DWIDP/JICA 2004a

The use of bioengineering techniques alone is mainly confined to river bank stabilization. By their nature, river banks provide a good environment for growth of vegetation. Left alone, banks usually have dense vegetation as the river provides nutrients in the form of silt and water to support growth. If vegetation is sufficient, both on the bank and in the river bed, it can stabilize the bank, lessen erosion, reduce the speed of flowing water, and reduce scouring by a flood wave. Where vegetation has been reduced or removed, it can be replaced by carefully selected planting of appropriate species to achieve the desired effect. Structures formed from a combination of dead and living plant material can also be used to guide the river course and prevent flood surges entering into settlements and farmland. The plants can provide additional benefits for the local population like fodder, fruit, and firewood, but this is secondary to the protective function.

As in slope protection, bioengineering can involve building a structure such as a fence to provide immediate protection, but using living branches that will take root and become an increasingly strong barrier. It can also involve a combination of dead and live vegetation, with a framework made of bamboo or timber, intertwined with living plants to grow and strengthen the structure. A good example is that of a permeable protection wall constructed out of bamboo porcupines (see river training chapter) intertwined with living plants to form a 'green wall'. Placed in the water or in regularly flooded areas of the bank, these structures trap silt in which they slowly become embedded, creating a strong stable self-sustaining bank with bamboo reinforcement held together by roots and vegetation.

In general, bioengineering is used in combination with physical techniques in river training rather than on its own. It is highly recommended as a means of reducing the impact of physical measures on the local ecology and landscape, and also for providing long-term strengthening of structures such as embankments.

## Common Bioengineering Techniques in the Hindu Kush Himalayas

The selection of the appropriate bioengineering treatment for a particular area depends on the site conditions, and requirements. Resource availability is a crucial factor. The following sections describe some of the techniques that can be used to control soil erosion, debris flows, landslides, and floods and flash floods in the Hindu Kush Himalayan region.

### Bamboo fencing

Bamboo fencing can be used to prevent soil creep or surface erosion on a slope (Figures 7 and 8), to hinder gully extension, particularly in seasonal water channels, and to control flood waves along a river bank. Live bamboo pegs can be used for the main posts so that the whole structure becomes rooted. The growing bamboo can be further interleaved between the posts (as in a wattle fence) to increase the strength of the fence. Shrubs and grasses are planted on the upper side of the fence to hold small soil particles. The main purpose is to trap loose sediments on the slope, to improve the conditions for growing vegetation, and to reduce the surface runoff rate.

Figure 7: Sketch of bamboo fencing

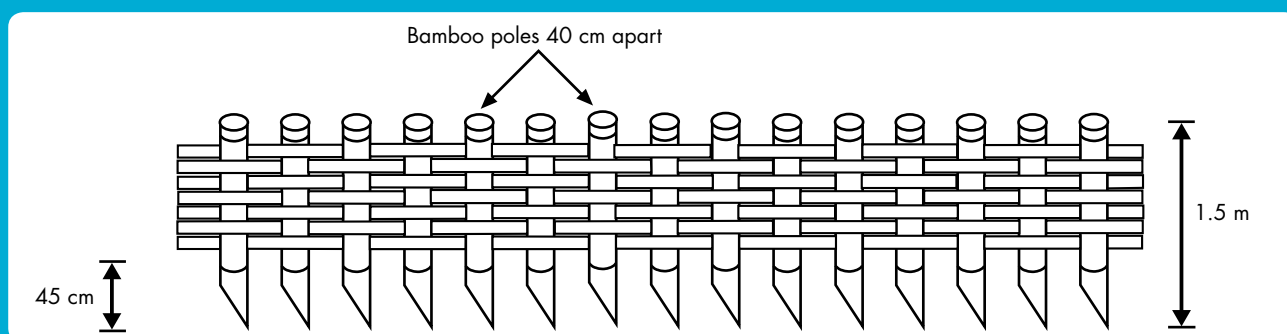

**Figure 8: Bamboo fencing on a slope – the posts (pegs) are live bamboo that will sprout to provide foliage (left); detail showing live bamboo peg with sprouting leaves (right)**

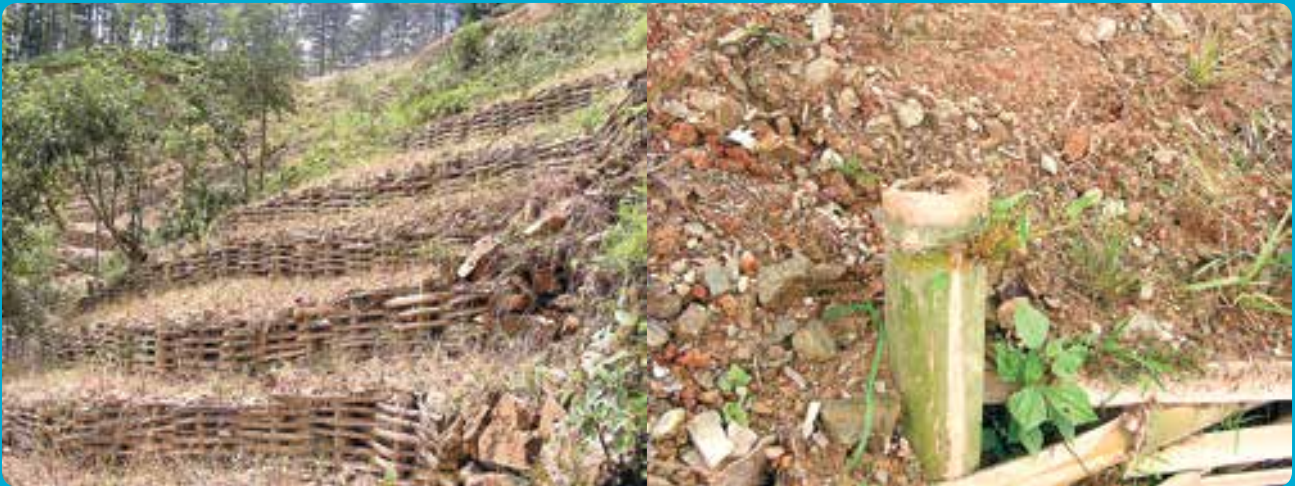

Source: DWIDP

## Materials

- Live bamboo pegs or strong bamboo poles about 1.5 m long and 10–15 cm in diameter
- Digging tools
- Seeds or plants of grasses or shrubs

## Installation

1. Starting from the base of the slope, mark the line for the fence with string.
2. Dig a long pit about 45–50 cm deep along the contour of the slope for each line of fencing.
3. Insert a row of bamboo poles or pegs 40 cm apart into the pit and back fill the pit to stabilize the poles.
4. Weave split bamboo or branches in and out between the poles to form a semi-solid face.
5. Plant small grasses and/or shrubs along the upper side of the fence.
6. Regular maintenance is important to ensure longevity of the fence. Any broken sections should be replaced immediately.

## Brush layering

In brush layering, live cut branches are interspersed between layers of soil to stabilize a slope against shallow sliding or erosion. Fresh green cuttings are layered in lines across the slope (Figures 9 and 10). As the roots grow, they anchor and reinforce the upper soil layers (up to 2 m depth), and the foliage helps to catch debris (Howell 1999, cited in Lammeranner et al. 2005). Some toe protection structures such as a wattle fencing, fiberschine, or rock riprap may be required to support brush layering.

## Materials

- Branches of different age and diameter cut from rooting woody plants of different species (e.g., willow, alder, *populus* spp., *garuga* spp., Malabar nut [*Justicia adhatoda*], mulberry, five-leaved chaste tree [*Vitex negundo*]). Branches should be at least 1 m long and 4 cm in diameter

**Figure 9: Brush layering**

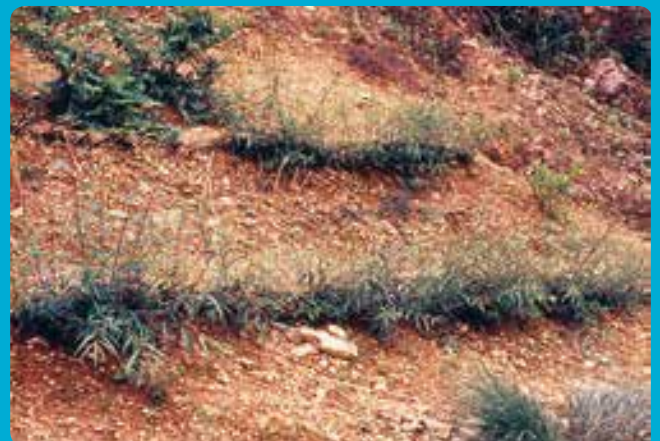

Source: Keshar Man Sthapit

Figure 10: Brush layering

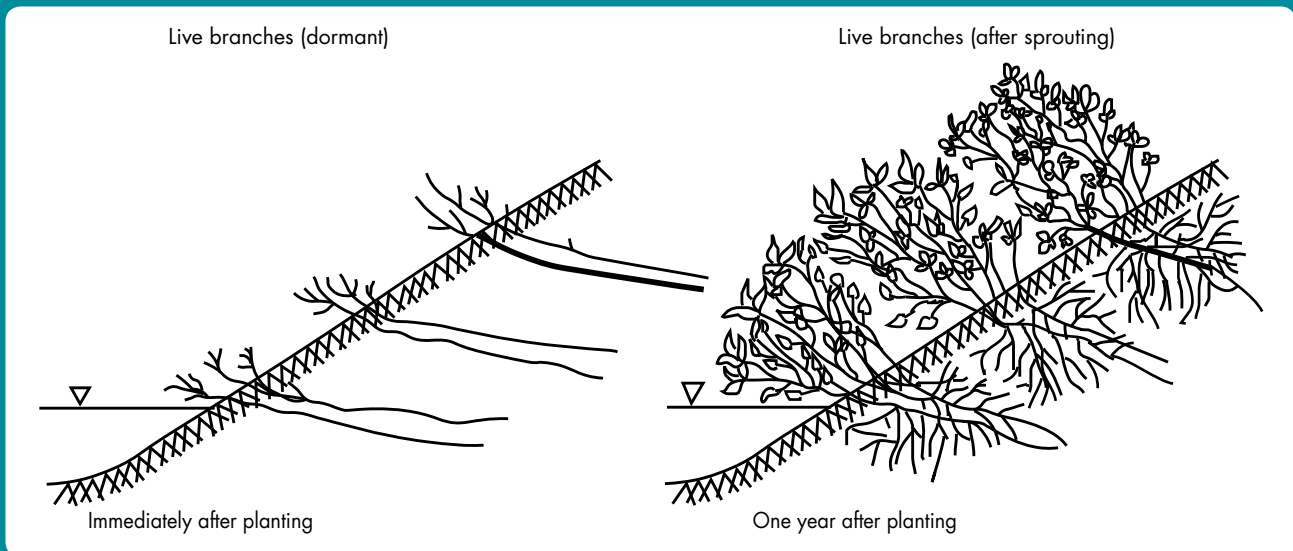

- Mixed plants of different easily growing species, both rooted and freshly cut
- Shovels or other digging tools
- Measuring tape and string line to calculate and mark the surface

### Installation

1. Mark lines across the slope to be planted at intervals of 0.5–1.0 m upwards from the base. The slope should have an inclination of at least of 10–20%. Dig a small channel along the line by hand or machine.
2. Cut fresh branches with a right angle at the top and 45° angle at the bottom. If possible, cut the branches on the same day that they are to be planted. Ensure branches are at least 1 m long with a mixture of different species. This will allow the root system to penetrate deeper into the soil, giving greater chances of survival and producing mixed vegetation.
3. Place branches in the dug terrace, with only  $\frac{1}{4}$ – $\frac{1}{5}$  of their length protruding (Figure 10).
4. Place rooted and unrooted plants of species that grow easily 0.5–1.0 m apart among the layers of branches.
5. Regular supervision and care is needed until the branches are fully rooted.
6. The pre-monsoon season is good for installing brush layering. If the site is moist, installation can be done in any season.

### Brush mattress

A brush mattress is a layer of interlaced live branches placed on a bank face or slope, often with a live fascine and/or rock at the base (Figures 11 and 12). The aim is to provide a living protective covering to an eroding bank to hinder erosion, to reduce the river velocity along the bank, and to accumulate sediment. The mattress is generally constructed from live stakes, fascines, and branches from species that root easily, but can be made from any brushy and woody branches to provide immediate and effective protection. A layer of biodegradable material such as loosely woven jute can be placed under the mat on steep slopes to increase stability if the soil is very loose. The mattress that is formed protects the surface of the bank until the branches can root and native vegetation becomes established.

### Materials

- Live branches 2–3 m long and approximately 2.5 cm in diameter
- Fascine bundles
- Live and/or dead wooden stakes
- Digging tools (shovel)



Figure 11: Cross-section of brush mattress

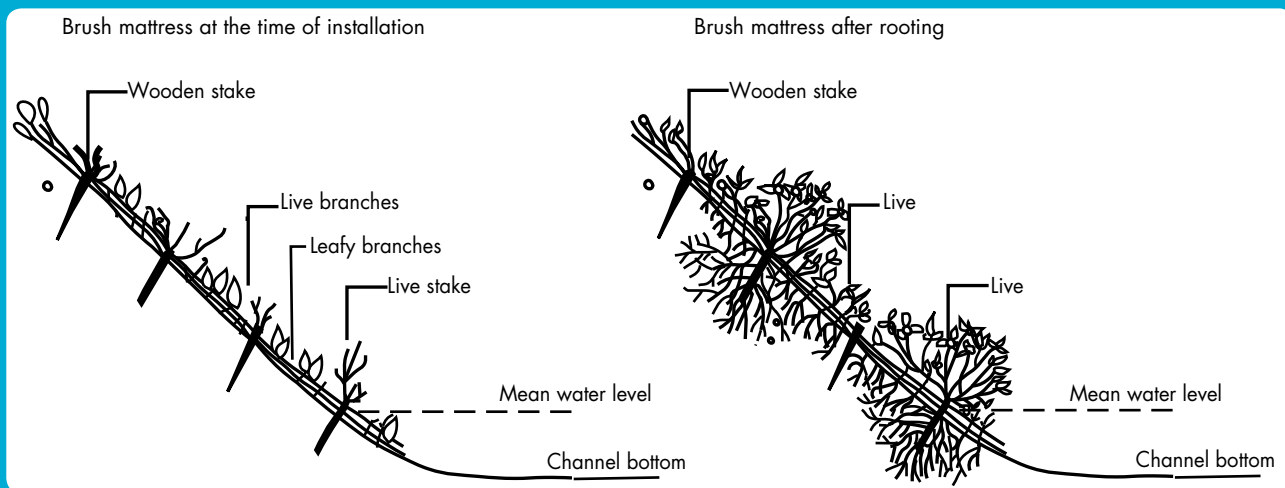

Figure 12: Installing brush mattress



Source: © Urban Creeks Council

## Installation

1. Prepare the site by clearing away large debris and other materials.
2. If desired, cover the slope with a layer of biodegradable material, e.g., jute netting, to provide extra stability.
3. Dig a horizontal trench 20–30 cm deep at the toe of the bank or slope.
4. Lie the cuttings flat on the graded slope in an overlapping crisscross pattern with the root ends pushed into the soil in the trench to below the water level and the growing tips placed at a slight angle in the direction of the stream flow (if on a stream bank) or parallel to the slope.
5. Branches should be placed at a density of approximately 4 branches every 15 cm.
6. Pound wooden stakes between the branches into the soil to half their length and about 1 m apart.
7. Wrap wire around the stakes and over the branches as tightly as possible.
8. Pound the wooden stakes further in to tighten the wire and press the branches down onto the slope.
9. Push live stakes into the ground between the wooden stakes.
10. Place bundles of fascines along the trench at the base of the slope over the bottom of the branches and cover with soil, leaving the tops slightly exposed.
11. Fill any voids around and in between the branches with loose soil (from the trench) to promote rooting.
12. Periodic maintenance is required to ensure the mattress is securely tied to the slope.

## Fiberschine

(adapted from Bentrup and Hoag 1998)

Fiberschine is a roll of material made from coconut fibre used to form a toe protection structure on a slope and to trap any sediment derived from erosion. The most common use is to stabilize the base of a stream bank or shoreline, but it can also be used in slope stabilization to support other measures such as brush layering. Live cuttings from herbaceous plants are planted together with the fiberschine; by the time the fiberschine decomposes, the vegetation will have stabilized the stream bank or slope. Fiberschine can usually be installed throughout the year, but the high water season should be avoided along streams. The following describes installation along a stream bank. The method can be adapted for use on a slope.

### Materials

- Fiberschine roll
- Wedge-shaped wooden stakes 60–90 cm long
- Twine or wire
- Herbaceous wetland plants or willow twigs

### Installation

1. Determine the length of the treatment area and obtain the necessary amount of fiberschine.
2. Place a roll of fiberschine along the toe of the stream bank at the level of the low flow line with approximately half the roll below the water line and half above. Place additional rolls of fiberschine along the bank for the extent of the treatment area. Tie the ends of adjacent fiberschine rolls together with strong twine.
3. Secure the fiberschine on both sides with wedge-shaped wooden stakes (60–90 cm) long at 1.5 m intervals. Cut a 7.5–10 cm deep notch in each stake about 12.5 cm from the top. Secure each pair of stakes together by binding around the notches. Drive the stakes in so that the twine is secured against the top of the fiberschine (Figures 13 and 14).
4. Key the ends of the fiberschine into the bank to prevent the flow from entering behind it and protect the ends with something hard such as rock to prevent scouring.
5. Backfill behind the fiberschine by knocking down the top of the stream bank onto the fiberschine.
6. Plant herbaceous wetland plants or willows into and behind the fiberschine at approximately 15–30 cm intervals.

Figure 13: Securing the fiberschine

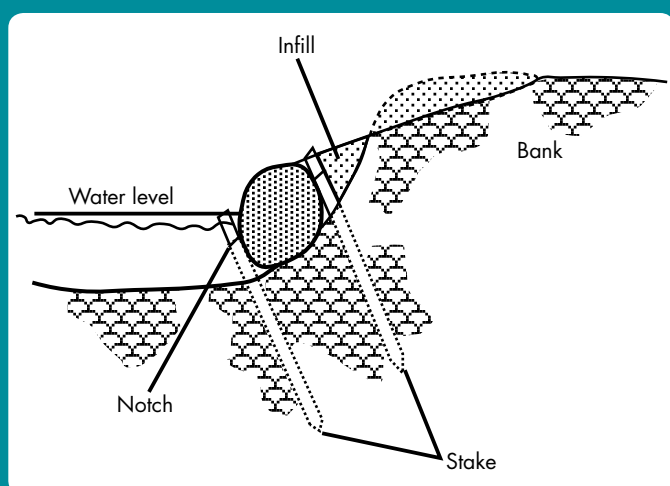

Source: Modified from Bentrup and Hoag et al. 1998

Figure 14: Fiberschine used to reinforce a river bank

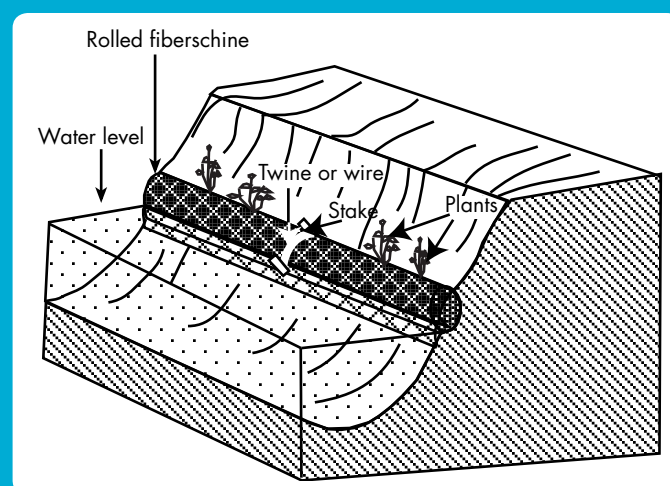

Source: Modified from Bentrup and Hoag et al. 1998

## Jute netting

Jute netting is a useful way of stabilizing steep slopes of 35–80° where it is difficult to establish vegetation (Figure 15). Locally available woven jute net is used as a form of armour on the slope and low growing grass is planted through the holes. The technique is often used in South Asia to reduce landslides along roads. The aim is to protect the bare slope from rain splash erosion, to improve the condition of the site, and to enable vegetation to become established by retaining soil moisture and increasing infiltration.

### Materials

- Woven jute net
- Digging tools
- Sledgehammer
- Live wood pegs
- Grass seed or small-rooted tufts of grass

### Installation

1. Trim the slope so that it is even and clear away any hanging masses or depressions.
2. Spread fertile soil on the bare slope.
3. Mulch with straw or other soft vegetation.
4. Start laying netting along a line above the slope to be covered, secure by hammering wooden pegs through the net at 0.3 m intervals.
5. Unroll the net down the slope and fix by hammering live wood pegs through it at intervals of 0.5–1.0 m.
6. Continue until the whole slope is covered by netting.
7. Sow grass seed or plant small grass clumps through the netting diagonally at a spacing of 10cm by 10cm over the entire area.
8. Regular supervision and care is needed until the grass is fully grown.

Figure 15: Jute netting on a cut slope



Source: DWIDP



Figure 16: Newly constructed live crib wall made of bamboo (left) and live crib wall on a slope (right)



Source: Madhav Dhakal

## Live crib wall

A crib wall is a box structure made of interlocking struts (either logs or precast structures made of concrete, recycled polymers, or other material) and back-filled with boulders, soil, or similar. They are mainly used to stabilize steep banks and protect them against undercutting, for example a stream bank or the side of a cutting made for a road, and are also a useful method for stabilizing the toe of a slope. However, they are only effective where the volume of soil to be stabilized is relatively small.

In a live crib wall, live branches and well-rooted plants are placed between interlocking logs where they can grow and develop a root network that further strengthens the wall (Figure 16). If needed, the anchor and cross logs can be held together with nails or bolts. Vegetated crib walls provide immediate protection, and their effectiveness increases over time as the vegetation grows. Once the plants become established, the vegetation gradually takes over the structural functions of the wooden supports (Gray and Sotir 1996 cited in Lammeranner et al. 2005). Crib walls should be installed at an angle of 10–15° towards the slope to increase stability. Green willow branches can be used to ensure a quick outcome.

### Materials

- Live branches 1–6 cm in diameter and long enough to reach from the front to the back of the structure with an overhang at both ends.
- Logs, timber, or bamboo 1–2 m long
- Steel reinforcing bars
- Excavator or digging tools (shovels), rakes, sledgehammers, knife, measuring tape, level instruments
- Rock and soil

### Installation

1. Excavate an area 1–2 m wide along the toe of the bank (stream bank or toe of a landslide) to a level around 1 m below the surface and fill with rock (Figure 17).
2. Place a series of large logs on the rock end to end along two lines marking the front and back of the wall.
3. Place smaller logs perpendicular to and towards the ends of the large logs from front to back of the wall to form the bottom layer of a box-like structure. Allow an overhang of about 15 cm in each direction. The logs can be fixed together with metal bars and nails.
4. Place a layer of live willow (or other) cuttings from front to back of the wall between the logs, and protruding over the front logs and extending into the slope behind the back logs.
5. Cover the branches with a layer of rock and soil and press down to fill the box.  
(Steps 4 and 5 can also be carried out in reverse order.)

Figure 17: Section view of live crib wall installed along a river bank

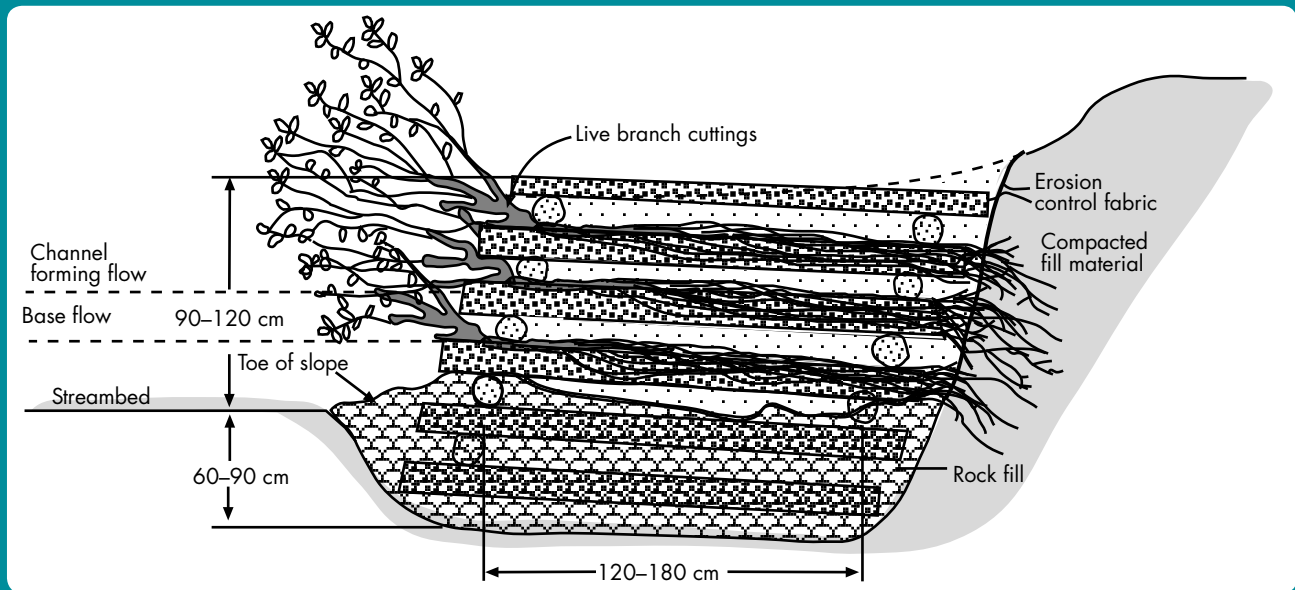

Source: Adapted from ODNR n.d.a

6. Continue for as many layers as needed to reach the desired height, alternating layers of soil and cuttings and logs and ending with soil. Each successive course of logs parallel to the bank should be set back by 15–20 cm from the log beneath.
7. To ensure success, the upstream and downstream sections should be well-secured to the bank to prevent undercutting.

## Live fascines

A fascine is a bundle of sticks or brushwood used in construction, generally to strengthen an earthen structure, fill ditches, or make a path across uneven or wet terrain. Live fascines are bundles of live branches intended to grow and produce roots. They can be placed in shallow trenches on a stream bank to reduce erosion across the bank and increase soil stability (Figure 18). The rooted branches protect the toe of the stream bank from erosion and improve infiltration. Properly placed, the bundles can also trap debris and sediment. Live fascines can also be used to reinforce slopes and increase drainage and infiltration. They are installed perpendicular to the slope in dug trenches or in existing gullies and rills. The optimum spacing depends on the steepness of the slope, usually 4 m intervals for slopes of less than 30° and 2 m intervals for slopes of 30–45°. They are most effective on soft cut slopes or slopes with consolidated debris. Draining effects can be seen as soon as the fascines are established (Schiechtel and Stern 1992, cited in Lammeranner et al. 2005).

## Materials

- Live branches of rooting plants of different species 3–5 cm in diameter and 50–100 cm or more long
- Live wooden stakes ready to sprout 3–6 cm in diameter and 50–100 cm long
- Dead wooden stakes 3–6 cm in diameter and 50–75 cm long
- Digging tools
- Jute or coir string or wire to bind the fascines

Figure 18: Installing live fascine



Source: Madhav Dhakal

## Installation

1. Prepare the site by clearing away loose material and protrusions and firmly infill any depressions (Figure 19).
2. Mark the lines along which fascines are to be installed. The lines should follow the contours, or be at a desired angle or along rills and at intervals of 2–4 m up the slope (2 m for slopes of 30°–45°; 4 m for slopes of less than 30°).
3. Excavate trenches approximately 10 cm deep and 20–40 cm wide along the marked lines starting from the bottom of the slope and working upwards.
4. Bind 4–8 live branches into bundles (fascines) using string or wire.
5. Place the fascines lengthwise in the trenches.
6. Drive live or dead stakes directly through the fascines every metre or so flush with the top of the fascines, and where the bundles connect.
7. Drive live stakes into the soil immediately below the fascines, protruding about 7 cm above the fascine.
8. Backfill the trench with moist soil to the side of the fascine, but allow the top of the fascine to show.
9. Riprap (see next chapter) can be used to stabilize the toe of the slope and prevent scouring.

## Palisades

A palisade is a fence or wall made from wooden stakes or tree trunks. Palisades were used historically as a defensive structure. In slope protection, palisades are barriers made from live wood cuttings or bamboo installed across a slope following the contour in order to trap debris moving down the slope, to armour and reinforce the slope, and to increase the infiltration rate. Palisades are used to prevent the extension of deep, narrow gullies and the erosion of V-shaped rills (Figure 20) by forming a strong barrier which stabilizes the gully floor and traps material moving downwards (Lammeranner et al. 2005). They are also effective on steep landslide or debris slopes. Palisades can be used on a wide range of sites with slopes of up to about 60°.

## Materials

- Stakes made from cuttings of rooting plants of different species 3–5 cm in diameter and 30–50 cm long
- Cross beam
- Gabion wire
- Digging tools such as crowbars and shovels

## Installation

1. Installation should start from the top of the slope and work down.
2. Clean or trim the site, remove unnecessary irregularities of slope and loose material.
3. Mark the places to be planted. Palisades should be spaced at intervals of about 2 m down a slope of less than 30° and 1 m down a slope of 30–60°.
4. Make holes with the help of a pointed bar or crowbar for planting the cuttings.
5. Trim the top of the cuttings at a right angle to the stem and the bottom at an angle of 45°.
6. Place at least two-thirds of the length of the cutting into the hole and pack the soil around it.
7. Tie the stakes with pieces of gabion wire to a cross beam which is anchored in the sides of the gully and protected by pegs at either end.
8. On steep gullies and rills, support the palisade by placing a layer of stone and soil in front of and below the structure (Figure 20).
9. Regular inspection is necessary throughout the year. Broken stakes should be repaired and strengthened to encourage vegetation to develop.
10. Thinning might be required after a few years.

## Wattle fence

A wattle fence is made by weaving flexible branches or vines between posts, rather like a large basket. A live wattle fence is constructed out of live branches which will root and continue to grow and strengthen the fence. The main purpose of wattle fences is to catch debris moving down a slope and to reinforce and modify the slope. Different

Figure 19: Live fascine installation on a river bank

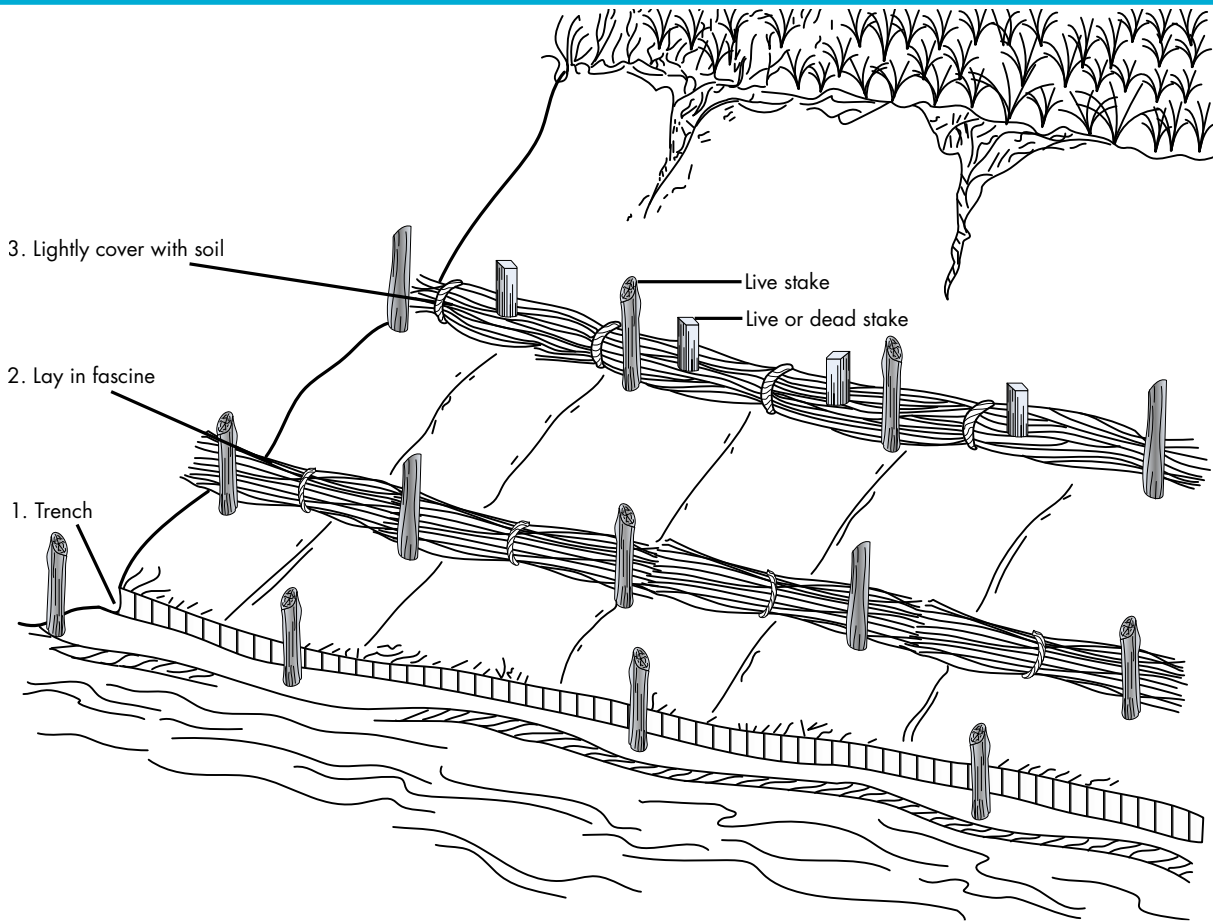

**Cross-section**

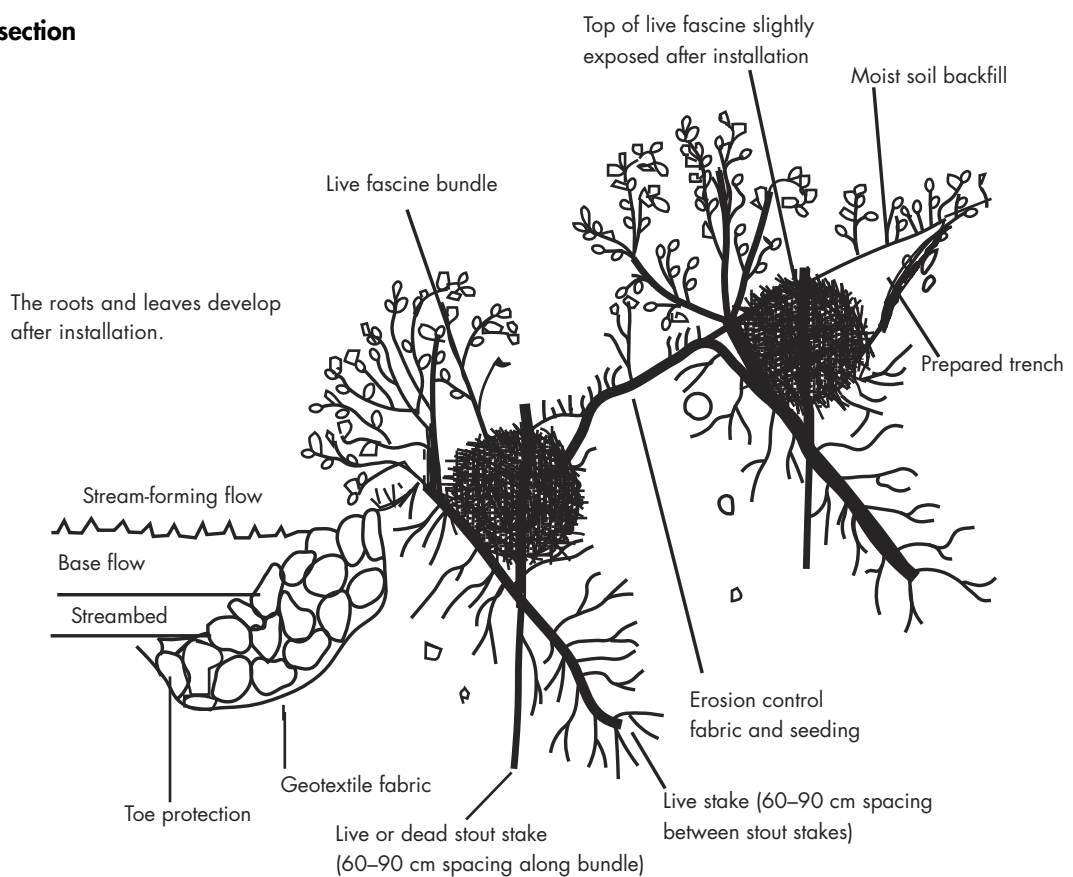

Source: Adapted from ODNR n.d.b



**Figure 20: Palisades**



Source: Madhav Dhakal

kinds of grass (e.g., broom grass and napier grass) and tree species can also be planted along the fence. Wattle fences are useful in small shallow short slides as well as for river bank protection if combined with other measures such as brush layering, live pegs, and rock riprap (Figure 21).

### Materials

- Sharpened stakes from plants 1 m long and 4–6 cm in diameter
- Shorter stakes 0.5 m long and 3–4 cm in diameter
- Long and flexible woody cuttings from plants which can root easily
- Jute or coir string or wire to bind
- Digging tools

### Installation

1. Prepare the site by clearing all loose material and protrusions.
2. Mark lines along contours on the slope where the fences are to be installed. Fences should be spaced at intervals of about 4–5 m down the slope, depending on the site and slope angle.
3. Dig holes at 1 m intervals along the lines for the stakes.
4. Insert 1 m long stakes in the holes and place two 0.5 m long stakes at equal distances between the long stakes. Both long and short stakes should protrude about 20–30 cm.
5. Dig out a trench at least 15 cm deep along the contour between the stakes.
6. Place the cuttings with their lower ends in the trench, and bend them down along the line of the fence. Firm the soil back into the trench. Weave the cuttings in and out between the stakes one above another to fill in the fence area.
7. If desired, add soil above the wattle fence for planting tree and grass seedlings and cuttings.
8. Regular supervision and maintenance is necessary, including weaving the branches in and out as they grow.

**Figure 21: Wattle fence used for river bank protection**



Source: Sundar Kumar Rai

# Chapter 5: Physical Methods for Slope Stabilization and Erosion Control

The bioengineering methods for slope stabilization and erosion control described in the previous chapter have a number of advantages. They are generally low cost and easy to install, and rather than disintegrating over time, their strength increases as root systems develop and the structures become more stable. However, such methods are not usually sufficient to withstand the volume of debris involved in mass failure, and are not appropriate for all the interventions required to reduce flash flood risk. Physical structures and techniques are also required for slope stabilization and erosion control. Various types of construction can be used to help retain soil and improve slope stability. The selection of measures always depends upon the site, the topography, and the required result. Proper selection and design of any measures plays a very important role in slope stabilization and the control of erosion and measures should only be undertaken as the result of an integrated planning process. Physical measures are often combined with bioengineering approaches to obtain the maximum effect.

Some of the major physical methods are described in this chapter. They can be divided broadly into measures to reduce runoff (terracing, diversions, grassed waterways, conservation ponds), methods to stabilize slopes and reduce erosion (retaining walls, drop structures, sabo dams), and integrated methods to address specific problems (gully control, trail improvement), although they all tend to have multiple functions.

## Terracing

Terracing is the technique of converting a slope into a series of horizontal step-like structures (Figure 22) with the aim of:

- controlling the flow of surface runoff by guiding the runoff across the slope and conveying it to a suitable outlet at a non-erosive velocity;
- reducing soil erosion by trapping the soil on the terrace; and
- creating flat land suitable for cultivation.

Terracing helps prevent the formation of rills, improves soil fertility through reduced erosion, and helps water conservation.

### Types of terrace

Terraces can be made in a variety of ways. The best approach depends on many factors including the steepness of the slope, the intended use, and the soil. The terraces are constructed with light equipment or by hand. The spacing between the terraces depends on the slope of land; the distance between terraces goes down as the slope increases. The three main types of terrace are bench, level or contour, and parallel or channel.

Figure 22: A terraced slope in Nepal



Source: Jack Ives

Level or contour terraces are constructed along slope contours with the main aim of retaining water and sediment. The terrace edge is planted with trees, small plants, and grass, usually with trees on the outward facing edge to increase stability.

Bench terracing is similar to contour terracing with the difference that the terraces do not strictly follow the contour line and runoff may run along as well as across the terrace. Bench terraces are primarily constructed to enable crops to be grown on sloping land, rather than to retain water and sediment. Bench terraces are recommended for slopes with gradient of up to 33%, but as a result of pressure on land are constructed on slopes up to 50–60% (Sharda et al. 2007).

Parallel or channel terraces are mainly used in heavy rainfall areas. They are also known as graded terraces as they have a constant slope or gradient along their length which is used to convey excess runoff at a safe velocity into a grassed waterway or channel.

Of these three, bench terraces are the most common type found in the mountain and hill areas of the Hindu Kush Himalayan region. Following is a brief description of bench terraces and a type of contour terracing that is particularly useful for stabilization. The construction of bench terraces is described in more detail in Box 7.

## Bench terraces

Bench terraces are particularly suitable where marked seasonal variations exist in the availability of water. The approach consists of converting relatively steep land into a series of horizontal steps running across the slope. These steps can be constructed by simply digging out the clayey soil, or they can be reinforced with locally available mud, stone, or brick. The terraces help conserve moisture during the long dry season, which is especially important where there are sandy and loam types of soil, and they help to slow and drain away runoff during the heavy rainfall monsoon season, which also helps counteract the tendency for sliding. There are three main types (Figure 23):

- outward sloping terraces, which are used to reduce a steep slope to a gentle slope;
- level terraces, which are used to impound water for paddy cultivation; and
- inward sloping terraces, which are the most suitable for steep slopes because they guide the surface runoff towards the hillside rather than down the slope.

Rainwater can be drained from outward sloping terraces along a ditch constructed along the toe of the riser. In inward sloping terraces, the riser is kept free from flowing water and is protected by a cover of grass.

Terrace design is influenced by the following factors (Sharda et al. 2007):

- soil depth and distribution of the top soil;
- slope of land;
- amount and distribution of rainfall; and
- farming practices and proposed crops to be grown.

When designing the terrace, it is necessary to select the type and determine the desired width, vertical interval and spacing, length, gradient, and cross-section (Box 7).

## Contour terraces

The main aim of contour terraces is to retain water and sediment. Contour terraces are similar to bench terraces, with the major difference that the terrace is formed along the contour, so that runoff flows across but not along the terrace. In addition, the terrace edge is planted with trees, small plants, and grass to stabilize it and trap sediment. The terraces can be constructed by excavating soil from the upper half and using it to fill in the lower half as for bench terraces, or can be allowed to form naturally using a technique called sloping agricultural land technology (SALT), or contour hedgerow intercropping (agroforestry) technology (CHIAT).

SALT combines the strengths of terracing with the strengths of natural vegetation to stabilize sloping land and make it available for farming. Double hedgerows of fast growing perennial nitrogen-fixing tree or shrub species are



Figure 23: Types of bench terrace

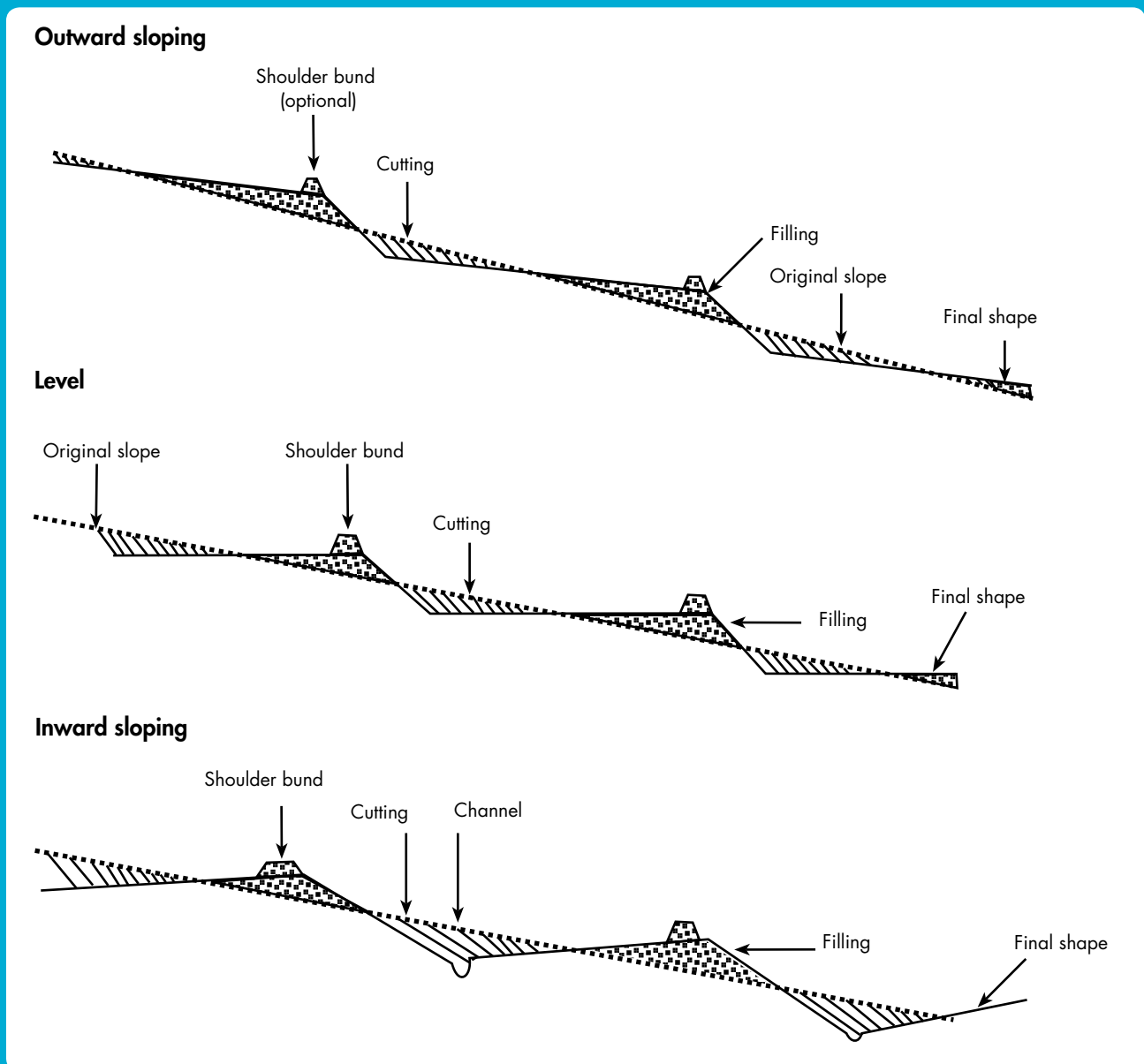

planted along the contour lines on a slope at a distance of 4–6 metres to create a living barrier that traps sediment carried downslope by runoff (Tang 1999; Tang and Murray 2004). As the sediment builds up, the sloping land is gradually transformed to terraced land. The space between the contour hedgerows is used for subsistence and cash crops. The hedgerows both markedly reduce soil erosion and contribute to improving and/or maintaining soil fertility through nitrogen fixation at the roots and incorporation of the hedgerow trimmings into the soil. SALT can be established on farmland slopes with gradients of 5–25% or more.

A combined approach has also been developed for improved terraces in which retaining walls are first constructed along the contours using cement bags filled with soil supported by bamboo cuttings along the contour. The soil is then excavated from the upper part of the terraces and used to build up the lower part above and behind the terrace riser wall to create a level bed; the fertile top soil is kept aside and later spread over the newly terraced fields. Grass and hedgerow species are then planted on the outermost margins of the terraces above the risers (ICIMOD 2008). The vegetation improves the terrace stability and increases moisture retention, while the construction means that the terraces are immediately ready for use, unlike the original SALT technique.

## Box 7: Design and construction of bench terraces

### Step 1: Selection of type

The type is selected according to the rainfall and soil conditions of the area. In general, outward sloping terraces are constructed in low rainfall areas with permeable soils; level terraces in areas with medium rainfall and/or highly permeable soils, or for growing rice; and inward sloping terraces in areas of heavy rainfall and less permeable soils.

### Step 2: Width

The width of the terraces is determined based on the soil depth, slope, amount and distribution of rainfall, and intended farming practices. Construction of very wide terraces is more costly, requires deep cutting, and results in a higher riser. However, at least two metres width is required for ploughing using bullocks (DSCWM 2005).

The formula for calculating the width of the terrace is given by Sharda et al. (2007) as

$$W = \frac{200 \times d}{S}$$

where

$W$  = width of the terrace in metres

$d$  = maximum depth of the cut (metres)

$S$  = slope of land (%)

### Step 3: Spacing

The spacing is the vertical interval ( $VI$ ) between two terraces. The terrace spacing depends on the soil type, slope, surface condition, gradient, depth of cut, and agricultural use. The depth of cut and fill have to be balanced, thus the interval is equal to double the depth of cut. The depth of cut must not be so deep as to expose the bed rock. The spacing is also linked to the terrace width.

The soil depth limits the maximum depth of cut and thus the maximum possible vertical interval. At the same time, the width of the terrace should permit economic agricultural operation. The following steps should be followed to take the different factors into account (Mal 1999).

- Ascertain the maximum depth of the productive soil by taking soil samples from different locations.
- Decide which crops are to be grown in order to calculate the depth of soil required and thus the maximum possible depth of cut. The depth of cut should be such that at least a minimum convenient width of terrace is obtained.
- If  $d$  is the maximum depth of cut, the vertical drop between two consecutive terraces is  $2d = D$  (Figure 24). And the corresponding horizontal distance is  $100D/S$  or  $200d/S$ .
- If  $W$  is the width of the bench terrace and the riser slope is 1:1, the horizontal distance for a drop  $D$  is  $(W + D)$ .

Figure 24: Design procedure for a bench terrace

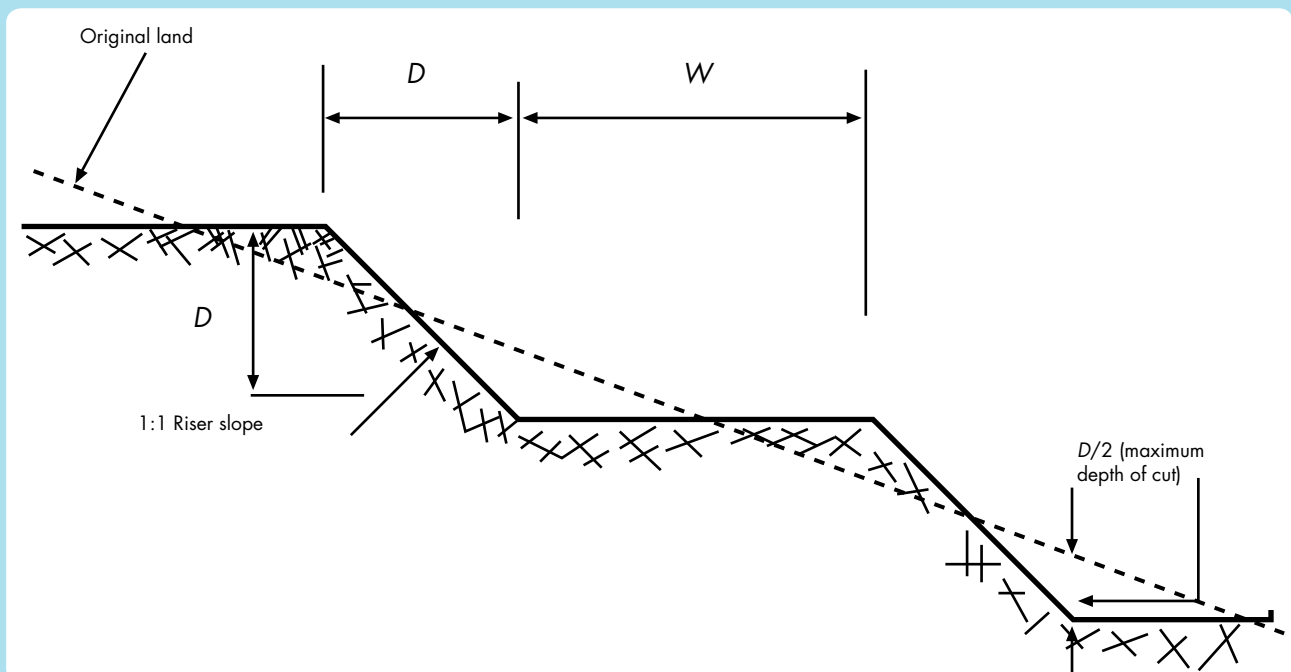

Therefore,  
 $W + D = 100D/S$  (Mal 1999).

If the riser slope is 1:1,

$$VI = D = \frac{S \times W}{100 - S}$$

Similarly, for a riser slope of 0.5:1, the horizontal distance for a drop  $D$  is  $(W + D/2)$ .

Therefore,  
 $W + D/2 = 100D/S$

or  $VI = D = \frac{2W \times S}{200 - S}$

Note: For a given slope, the greater the VI, the greater the width. For a given VI, the steeper the slope, the smaller the width.

#### Step 4: Length

The length of the terrace is determined by many factors including the shape and size of the land, degree of dissection of the land, and permeability and erodibility of the soil. Longer terraces are more efficient for agriculture and cost less to install, but they may increase the velocity of surface runoff thus increasing erosion (DSCWM 2005).

#### Step 5: Gradient

It is also important to determine the gradient along the terrace. It would be best to select the gradient in accordance with the rainfall intensity, soil permeability, and width and length of the terrace. But it can also be determined using the simpler approach of 1 m for every 100 m terrace length, or not more than 1%. In low rainfall areas with highly permeable soil, the gradient can be lower than 0.5%, whereas in high rainfall areas with low permeable soil, 1% is preferable to reduce excess run-off. The gradient can also vary, for example for a terrace around 100 m long, 0.25% for the first 25 m, 0.5% for the next 50 m, and 1% for the remainder.

#### Step 6: Cross-section

In bench terraces, soil excavated from the upper half is deposited on the lower half. In other words, the volume of cut is equal to the volume of fill (Mal 1999). The volume of soil after excavation is calculated in terms of loose cubic metres (LCM), and is more than the volume before excavation (banked cubic metres or BCM). All calculations should be done in BCM. Filling in LCM should be calculated such that the proper height will be obtained after settling. For land with a slope in the range 10–15%, a platform approximately 8 m wide should be constructed. The width is reduced to about 5–8 m for a slope of 15–25%, and about 3 m for a slope of 25–33%. The shoulder bund is constructed with a trapezoidal shape (1:1 side slope) and a height of 15–30 cm. A bottom width of 75 cm is provided for stability (Figure 25).

Figure 26 shows the typical appearance of bench terraces shortly after construction and some years later.

#### Worked example (adapted from Mal 1999)

**Problem:** Design a 120 m long bench terrace for a sandy loam soil with an average slope of 16%. The entire width of the terrace acts as a channel which is provided with a uniform gradient of 0.6%. Rainfall intensity for a 10 year recurrence interval and the time of concentration is 24 cm/hr. (The time of concentration is the time needed for water to flow from the most remote point in the watershed to the watershed outlet.)

**Solution:** An inward sloping terrace should be used (Figure 25). As the average slope is 16%, the width of the terrace is selected as 6 m or  $W = 6$  m. A final slope of 5% is provided so that the inner side of the terrace is 30 cm lower than the outer side.

Average slope ( $S$ ) = 16%, width of the terrace ( $W$ ) = 6 m.

The terrace spacing ( $VI$ ) is given by

$$VI = \frac{S \times W}{100 - S} = \frac{16 \times 6}{100 - 16} = 1.143 \text{ m.}$$

The following standard dimensions are assumed: riser side slope = 1:1, shoulder bund height = 30 cm, bottom width = 75 cm, side slope = 2:1

The area of the terrace that has to be drained by the channel is calculated using the formula:

$$A = \frac{L \times W}{10,000}$$

where

A = area to be drained (ha)

L = length of terrace (m)

W = width of terrace (m)

Thus, the area of terrace,  $A = \frac{120 \times 6}{10,000} \text{ m}^2 = 0.072 \text{ ha}$ .

**Figure 25: Design of (inward sloping) bench terrace (not to scale)**

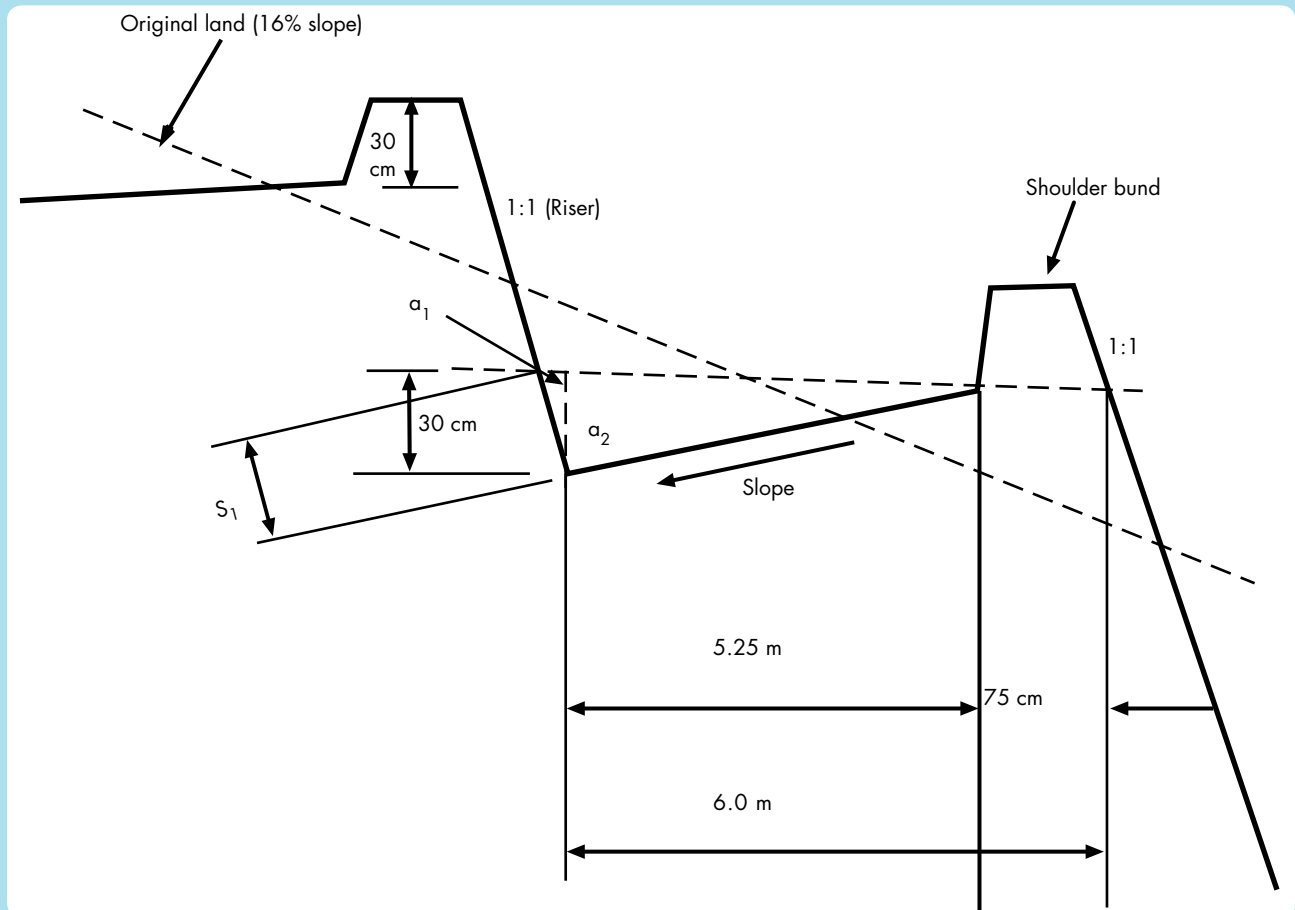

**Figure 26: Newly constructed bench terraces on a slope (left) and the same terraces some years later (right)**



Source: DWIDP

For a sandy loam soil, the runoff coefficient = 0.3. The peak discharge to be handled is obtained from the rational runoff formula:

$$Q = \frac{C \times I \times A}{36} \text{ (Mal 1999) ,}$$

where

$Q$  = rate of runoff in cubic metres per second,

$I$  = rainfall intensity, that is the rate of rainfall in mm/hr for a designed frequency for a duration equal to the time of concentration ( $t_c$ ),

$A$  = area of watershed in hectares, and

$C$  = dimensionless runoff coefficient.

Thus,

$$Q = \frac{0.3 \times 24 \times 0.072}{36} = 0.0144 \text{ m}^3 \text{ per second}$$

The area of flow can be calculated from Figure 25:

$$a_1 = \frac{1}{2} \times 0.30 \times 0.30 = 0.045 \text{ m}^2,$$

$$a_2 = \frac{1}{2} \times 5.25 \times 0.30 = 0.7875 \text{ m}^2.$$

The total area of flow is  $a = a_1 + a_2 = 0.8325 \text{ m}^2$ .

$$s_1 = \sqrt{(30^2 + 30^2)} = 42 \text{ cm} = 0.42 \text{ m}; \quad s_2 = \sqrt{(0.30^2 + 5.25^2)} = 5.259 \text{ m},$$

where  $s_1$  and  $s_2$  are the perimeter of water flow.

The wetted perimeter ( $P$ ) is calculated as:

$$P = s_1 + s_2 = 5.679 \text{ m},$$

$$R = a/P = 0.8325/5.679 = 0.147 \text{ m}.$$

Using Manning's formula, the velocity of flow ( $V$ ) can be calculated from

$$V = \frac{1}{n} \times R^{\frac{2}{3}} \times S^{\frac{1}{2}}$$

$$V = \frac{(0.147)^{\frac{2}{3}} \times (0.006)^{\frac{1}{2}}}{0.04} = 0.538 \text{ m/s}.$$

The velocity is non-erosive. The discharge carrying capacity  $Q = aV = 0.8325 \times 0.538 = 0.45 \text{ m}^3/\text{s}$ . When the terrace acts as a channel it has sufficient carrying capacity.

## Diversions

Diversions are ridges of soil or channels with a supporting ridge on the lower side. They are built across the slope to intercept runoff and dispose of it at a selected location. They are used to break up long slopes, to direct water away from active erosion sites, to direct water around agricultural fields or other sites, and to channel surface runoff to suitable outlet locations. Safe passage of the surface runoff to prevent slope failure can be achieved by installing drainage ditches, or by cross drainage work for road structures.

### Slope drainage

The simplest way to safely drain off springs and surface water is to use an open ditch (drain) or a system of open ditches. The main ditch is located in the direction of the slope gradient (downhill); secondary or lateral ditches are located in a fishbone pattern (Figure 27). Water should be collected as

Figure 27: Arrangement of ditches on the slope

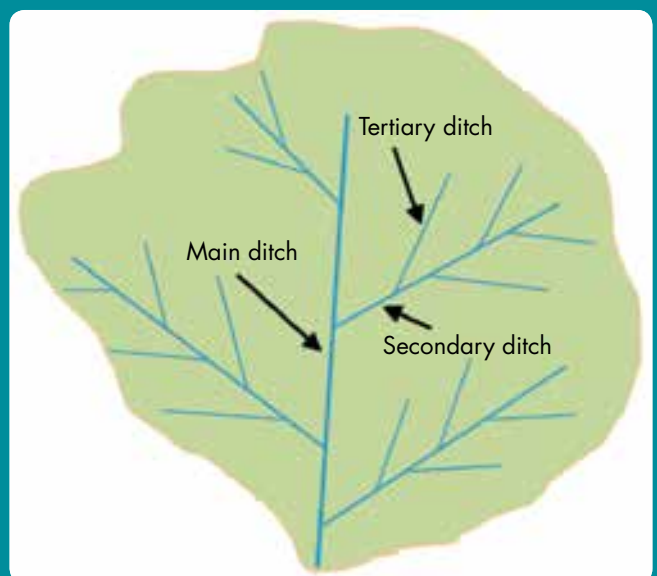

close as possible to its origin and channelled to a side drain, culvert, or any other nearby water course. Ditch excavation should start at the lowest point and work up in order that the accumulating water may drain off immediately. The most common types of drain are stone or gravel-filled drains with or without pipes.

Pipe drains are the most efficient and effective, but they are more expensive and often not locally available. Normal stone drains may silt up over time and it is advisable to form a drainage channel of stones, or place a bundle of brushwood, at the bottom of the drain. The top of the drain should be covered with a layer of grass to prevent siltation.

### Simple drainage ditches

Drainage ditches can be constructed with different shapes and sizes (Figure 28). The appropriate size and shape for a particular site depends upon such factors as the expected runoff, site condition, and availability of resources and construction materials.

Figure 28: Simple designs for drainage channels

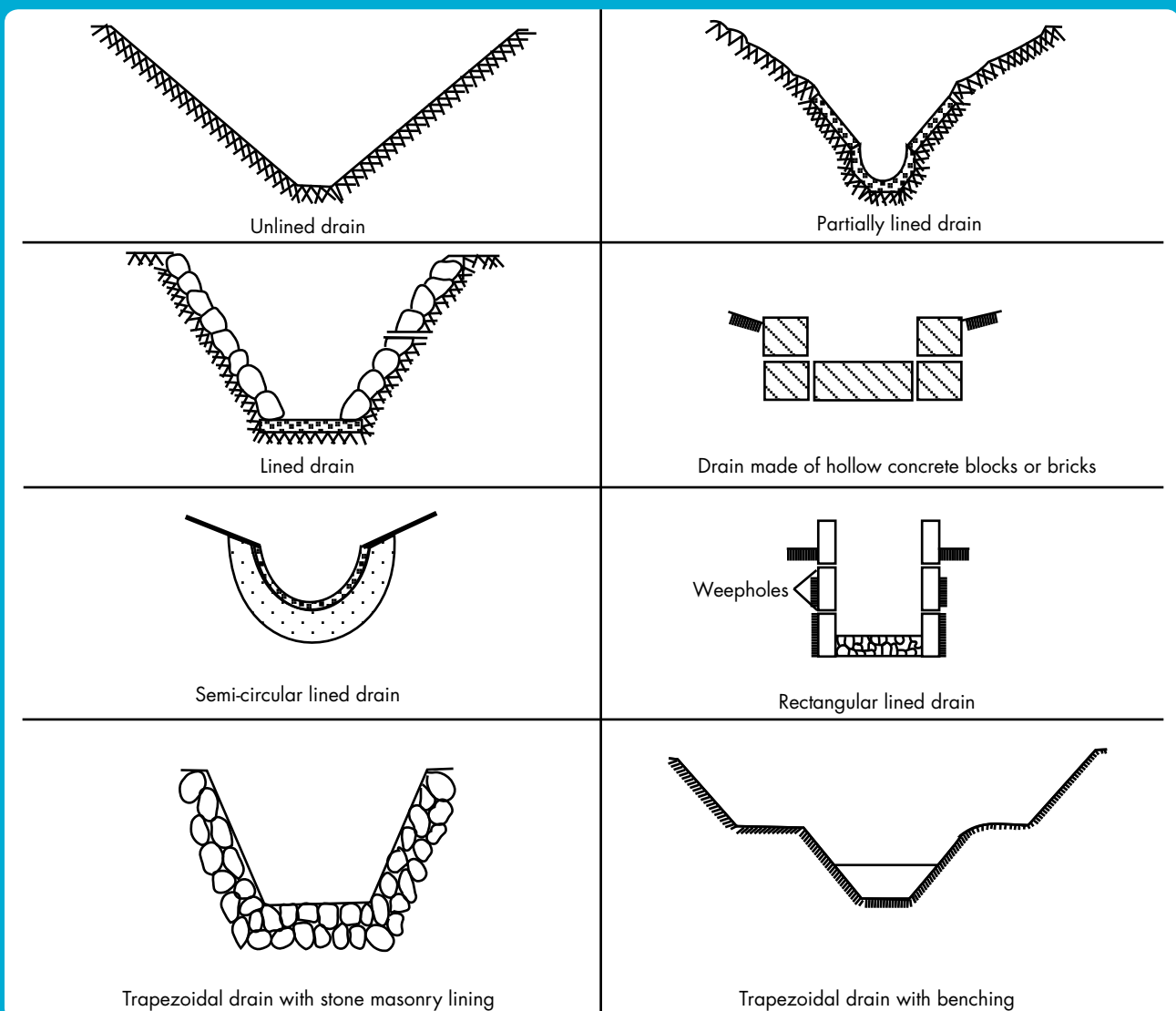

Source: based on WHO/UNEP 1991



Figure 29: Grassed waterway

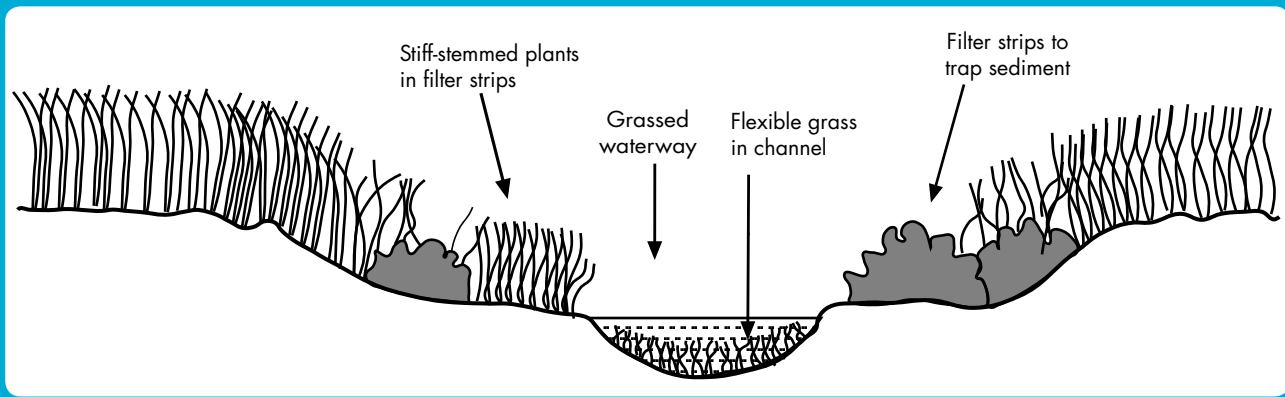

Source: Modified from Bentrup 2008

## Grassed Waterways

(adapted from Sharda et al. 2007)

Grassed waterways are natural or artificially constructed water courses shaped or graded to the required dimensions and planted with suitable vegetation (Figures 29 and 30). Grassed waterways generally run down a slope and are designed to conduct surplus water safely into natural drainage courses. They are usually made broad and shallow, although the shape and size can vary depending on the size of the drainage area, slope of the land, and soil type. The channels help surface water to flow across the land without causing soil erosion. They are used as outlets to prevent rill and gully formation. The vegetation in the channel helps control the water flow and reduces channel surface erosion. Properly designed grassed waterways can safely transport large volumes of water to the down slope. They are also used as filters to prevent sediments entering into nearby water bodies. Grassed waterways are used as

- outlets for diversions and emergency spillways;
- to safely convey runoff from contour and graded bunds and bench terraces;
- as outlets for surface and sub-surface drainage systems on sloping land;
- to carry runoff from natural drains and prevent formation of gullies; and
- to dispose of water collected in road ditches or discharged through culverts.

The design of grassed waterways is described in Box 8.

## Conservation Ponds

Conservation ponds, also known as farm ponds, are small reservoirs constructed for the purpose of collecting and storing water from surface runoff. Storing water runoff during excessive rainfall helps to reduce the peak flow and surface erosion and thus reduce the probability of floods. It is also useful for providing supplemental irrigation for agriculture, water for domestic purposes, and fish farming. Conservation ponds play a significant role in areas with rainfed agriculture, and construction of a large number of ponds in a catchment area can have a significant effect

Figure 30: Grassed waterway



Source: Keshar Man Sthapit



## Box 8: Design of grassed waterways

When designing a grassed waterway, it is first necessary to determine the required shape, size, and gradient.

### Shape

Usually a waterway can be triangular, trapezoidal, or parabolic. A parabolic shape is hydrologically more efficient and easier to construct. The other two shapes tend to become parabolic over time as a result of bank erosion and deposition of sediments across the channel section.

### Size of waterway and calculation of peak discharge

The size of the waterway is calculated on the basis of the peak rate of runoff expected from a ten-year return period storm without scour or fill. The peak runoff rate can be estimated using the rational method. The rational runoff coefficient varies according to land use and soil type (Table 4). The catchment area of the grassed waterway increases towards the outlet and the size of the waterway should be increased accordingly.

The rational equation, in imperial units, is

$$Q = C \times i \times A$$

where

Q = peak discharge in cubic feet per second (ft<sup>3</sup>/s),

C = rational method runoff coefficient,

i = rainfall intensity, inches/hr, and

A = drainage area in acres.

The rational method runoff coefficient (C) is a function of the soil type and drainage basin slope. The rainfall intensity (i) is typically found from intensity/duration/frequency curves for rainfall events in the geographical region of interest. The duration is usually equivalent to the time of concentration of the drainage area. The resultant Q can be divided by 35.3 to convert from ft<sup>3</sup>/s to m<sup>3</sup>/s.

**Table 4: Rational method runoff coefficients (C) for different land cover areas and soil types**

Land use and topography	Soil type		
	Sandy loam	Clay and silt loam	Tight clay
Cultivated land			
Flat	0.30	0.50	0.60
Rolling	0.40	0.60	0.70
Hilly	0.52	0.72	0.82
Pasture land			
Flat	0.10	0.30	0.40
Rolling	0.16	0.36	0.55
Hilly	0.22	0.42	0.60
Forest land			
Flat	0.10	0.30	0.40
Rolling	0.25	0.35	0.60
Hilly	0.30	0.50	0.60
Populated area			
Flat	0.40	0.55	0.65
Rolling	0.50	0.65	0.80

Note: The value of the rational method runoff coefficient can vary from close to 0 to 1.0. A low C value indicates that most of the water is retained for a time on the ground surface and soaks into the ground, whereas a high C value means that most of the rainwater runs off immediately.

Source: Suresh 1997

### Flow velocity

The flow velocity in a grassed waterway depends upon factors such as the soil type, water quality, and ability of the vegetation to resist erosion. Similarly, the permissible velocity of flow in a waterway varies with the type, condition, and density of vegetation. The maximum permissible velocities recommended by the Central Water and Power Research Station (CWPRS) Pune for canals for different types of soils are shown in Table 5. Permissible velocities for sod forming grasses are higher than those for bunch grasses or other non-uniform grasses. In a grassed waterway, the average flow velocity near

the top is always higher than the velocity in contact with the channel bed, as surface roughness is greater at the bed.

### Gradient

The slope of the land normally determines the gradient of the waterway. Usually, a gradient of less than 5% is preferred; in a normal course it should not exceed 10%.

### Design of the cross-section

The catchment area of the grassed waterway increases towards the outlet and the size of the waterway should be increased accordingly. The cross-sectional area is calculated from the formula

$$A=Q/V$$

where

A = cross-sectional area of flow,

Q = peak discharge, and

V = cross-sectional average velocity.

Q is calculated using the rational method (above) and V is calculated using Manning's formula to calculate the cross-section average velocity flow in an open channel:

$$V = \frac{1}{n} \times R^{\frac{2}{3}} \times S^{\frac{1}{2}}$$

where

V = cross-sectional average velocity (m/s),

n = Manning's roughness coefficient,

R = hydraulic radius (A/P) (m),

A = cross-sectional area of flow (m<sup>2</sup>),

P = wetted perimeter (m), and

S = slope (m/m).

The value of n can be taken as 0.035, or 0.04 for freshly constructed earthen channels.

Assume either the width or the depth and calculate the dimensions of the channel from A. Check whether the computed velocity of flow is within the permissible limits. If not, adjust the channel dimensions to bring the velocity of flow within the permissible limits. Add a suitable freeboard (height between water level and top of the bank) of 20% extra depth or a minimum of 15 cm to the design depth of the waterway as obtained above to account for any higher flood.

**Table 5: Recommended maximum permissible velocity for different soils**

Soil type	Maximum permissible velocity (m/s)
Ordinary soils	0.6–0.9
Very light loose to average sandy soil	0.3–0.6
Sandy loam, black cotton soil, and similar soil	0.6–0.9
Hard soil	0.9–1.1
Gravel and disintegrated rock	1.5

Source: NABARD 2012

on downstream flow and control of floods. Water storage is a topic of increasing importance in the Hindu Kush Himalayas as the focus turns toward adaptation to climate change, and conservation ponds and other storage mechanisms are likely to play an increasing role in future development activities (Vaidya 2009; Upadhy 2009).

Conservation ponds can be broadly classified into embankment type ponds and dugout type ponds.

## Dugout ponds

The types of dugout ponds range from the very simple, which require no explanation, to forms specifically designed to collect water on a slope for infiltration and recharge purposes. Some selected types are described below.

Simple earthen ponds are cheap and durable but have high seepage losses that reduce effectiveness. Vertical and horizontal seepage loss can be significantly reduced by compacting a 30 cm deep layer of heavy clay on the floor and walls of the pond. Addition of cow-dung and puddling will help seal seepage pores. Watering of buffaloes in such ponds also helps reduce seepage. High density polythene sheet or SILPAULIN (multi-layered, cross laminated, ultraviolet stabilized plastic sheet) can also be used to reduce seepage (Figure 31).

Figure 31: Earthen ponds laminated with plastic sheet



Source: ICIMOD 2007

Eyebrow pits are a special type of dugout pond used to reduce runoff across a slope and thus stabilize degraded slopes and increase infiltration and recharge of springs. Small curved trenches around 2 m long and 50 cm wide in the shape of an eyebrow are dug at intervals facing inward to the slope to catch water and slowly return it to the soil. Grass and fodder species are planted along the lower ridges of the pits (ICIMOD 2007).

### Embankment type ponds

(adapted from Sharda et al. 2007)

Embankment type ponds are constructed to collect runoff at the base of a slope. They can be constructed across dry water beds or courses with a gentle to steep slope that fill when it rains. Usually, an earthen dam is constructed between two hillsides to hold back the water from overland runoff. The pond bottom and dam should be made up of soil that prevents excess seepage. Embankment ponds should not be built by damming any stream with permanent flow, no matter how small. The dimensions depend on the volume of water to be stored. The location should be sufficiently depressed to enable the maximum storage volume to be obtained with the least requirement for earthworks.

The design of embankment type ponds is described in Box 9, and the steps in their construction are elaborated in Box 10.

**Seepage control.** Seepage is almost inevitable in any dam or embankment structure. It mainly occurs through the embankment and under the foundation. The following methods can be used to control seepage.

- **Core wall:** A core wall is constructed using impervious materials and checks the flow of water in the dam. The main purpose of the wall is to add strength to the bund and increase the seepage gradient length through the embankment.
- **Filter and toe drains:** These drains are constructed by including a layer of coarse material in the dam section to attract the flow of water and bring the saturation line down to the level of the drain.
- **Berm:** A berm is a horizontal structure built on the lower part of the downstream (outward) face of the dam to prevent seepage from the face and keep the seepage line within the base of the dam section. It increases the base width of the embankment.
- **Cut off wall:** A cut off wall is constructed to join the impervious foundation to the base of the dam and prevent piping.

**Spillway.** A spillway is an opening constructed in the embankment to allow water to exit the pond once it is at the desired level. The size and type of spillway depends upon the size and characteristics of the watershed and the site conditions. There are two types of spillway: mechanical and emergency. A mechanical spillway is used to let out

### Box 9: Design of an embankment type pond

Designing the pond involves calculating the dimensions (height, width, side slopes), and considering how to control seepage and provide a spillway.

#### Height

The dam height should be no more than 16 m, otherwise special design criteria for stability must be used. The height of the dam is also called the top bund level (TBL) of the embankment. It is calculated using the formula:

$$\text{TBL} = \text{FTL} + \text{flood depth} + \text{freeboard} + \text{settlement allowance},$$

where

FTL = the full tank level of the reservoir. This is the required storage volume and is determined by the depth capacity curve for the location where the dam is to be constructed.

Freeboard = height added to the dam as a safety factor to prevent waves and runoff from storms greater than the design frequency from overtopping the embankment. Normally, 10–15% of the height is added as freeboard to the highest flood level of the dam, with a minimum of 50 cm.

The height of the earth fill along the central line of the dam is determined from the cross-section profile of the ground at the central line and the calculated height of the embankment.

#### Top width

The top width is calculated from the formula:

$$W = (H/5) + 1.5,$$

where

$W$  = the top width, and

$H$  = height of the dam.

In general, a minimum top width of 2.5 m is recommended for dams up to 5 m high.

#### Side slope

The slope used for the sides depends upon the nature of the fill materials. When fill materials are stable, the side slopes can be steeper and vice versa. The recommended side slopes for earthen embankments are shown in Table 6.

**Table 6: Side slopes for embankments made of different materials**

Type of material	Upstream slope	Downstream slope
Homogeneous well-graded material	2.5:1	2:1
Homogeneous coarse silt	3:1	2.5:1
Homogeneous silty clay or clay		
• Height less than 15 m	2.5:1	2:1
• Height more than 15 m	3:1	2.5:1
Sand or sand and gravel with clay core	3:1	2.5:1
Sand or sand and gravel with reinforced cement concrete (RCC) core wall	2.5:1	2:1

Source: Sharda et al. 2007

## Box 10: Construction of an embankment type pond

### Step 1

Completely clear large stones, bushes, and tree stumps from the site of the pond and plough and excavate the top soil to a depth of 10 cm. Stockpile the excavated soil on the downward (outward) side of the dam. It can be used later to provide a base for adding grass sod on the downward side.

### Step 2

Mark out the layout for the main embankment, core wall, and mechanical and emergency spillways using stakes or lime powder.

### Step 3

Excavate a cut-off trench along the bottom length of the dam as per the design depth, bottom width, and side slopes. Excavation is generally at least down to the layer of impervious material.

### Step 4

Fill the cut-off trench with the best available clay, compacting layer by layer, up to the desired height to form the core wall.

### Step 5

Cover the core wall with layers of excavated earth, compacting each layer, to form a bund of the selected dimensions. Compaction is normally achieved using rollers with pneumatic tyres and sheep foot rollers after slightly moistening the earth fill to achieve optimum moisture content.

### Step 6

Start constructing the mechanical spillway when the embankment construction reaches the bottom level of the spillway (Figure 32). Take special care to compact the material around the spillway components to avoid unequal settling. Place pipes, anti-seep collars, and other equipment, and then back fill with earth. Cover the pipe with at least 1 m of earth before allowing any heavy equipment such as trucks or tippers to pass over it. Proceed in the same way with the emergency spillway.

Figure 32: Location of mechanical and emergency spillways

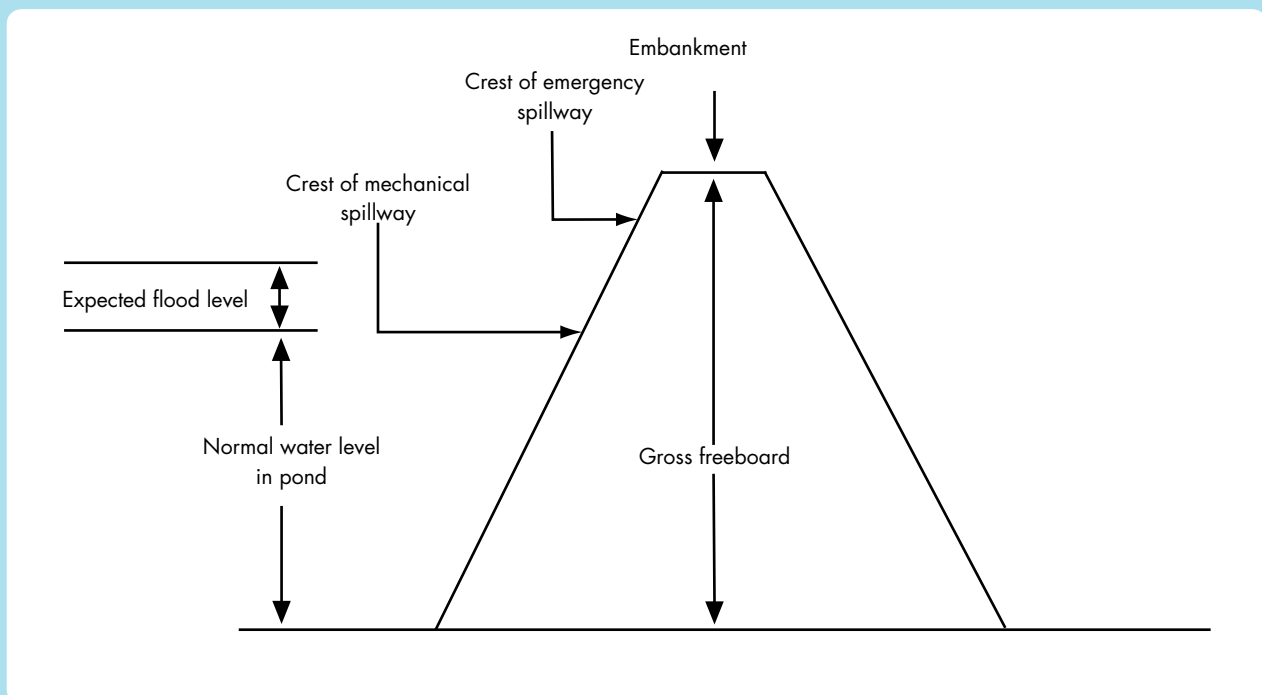

Source: Sharda et al. 2007

excess storage water safely; whereas an emergency spillway is used as a safeguard for the earthen embankment against overtopping when the inflow exceeds the capacity of the mechanical spillway.

## Retaining Walls

Retaining walls are artificial structures that hold back soil, rock, or water from a building, structure, or area. Retaining walls prevent down slope movement and soil erosion, and provide support for vertical or near-vertical changes in gradient. The walls are generally made from timber, masonry, stone, brick, concrete, vinyl, steel, or a combination of these. Retaining walls act to support the lateral pressure exerted by a soil mass which may cause slope failure. Retaining walls are strongly recommended where the toe of slope has collapsed and the slope failure is likely to progress upward along the slope. Retaining walls should be constructed on a stable foundation. Their design is described in Box 11.

Retaining walls are categorized in two ways: based on the mechanics of performance, and based on the construction material.

### Types based on the mechanics of performance

**Gravity retaining wall.** A gravity retaining wall is low and depends on its own weight or mass to hold back the earth behind it (Figure 33a). It is constructed with a large volume of material in such a way that, when stacked together, the weight and friction of the interlocking material exceeds the forces of the earth behind. The wall supports the pressure from the earth by means of its dead weight, and generally requires a good foundation with sufficient bearing capacity. The wall is thicker at the bottom than at the top; the thickness at the base should be between one-half and three-quarters of the height. Gravity walls are very cumbersome to construct because they require large amounts of material. They are usually constructed with concrete and masonry. The size of the section

Figure 33: Types of retaining wall based on the mechanics of performance

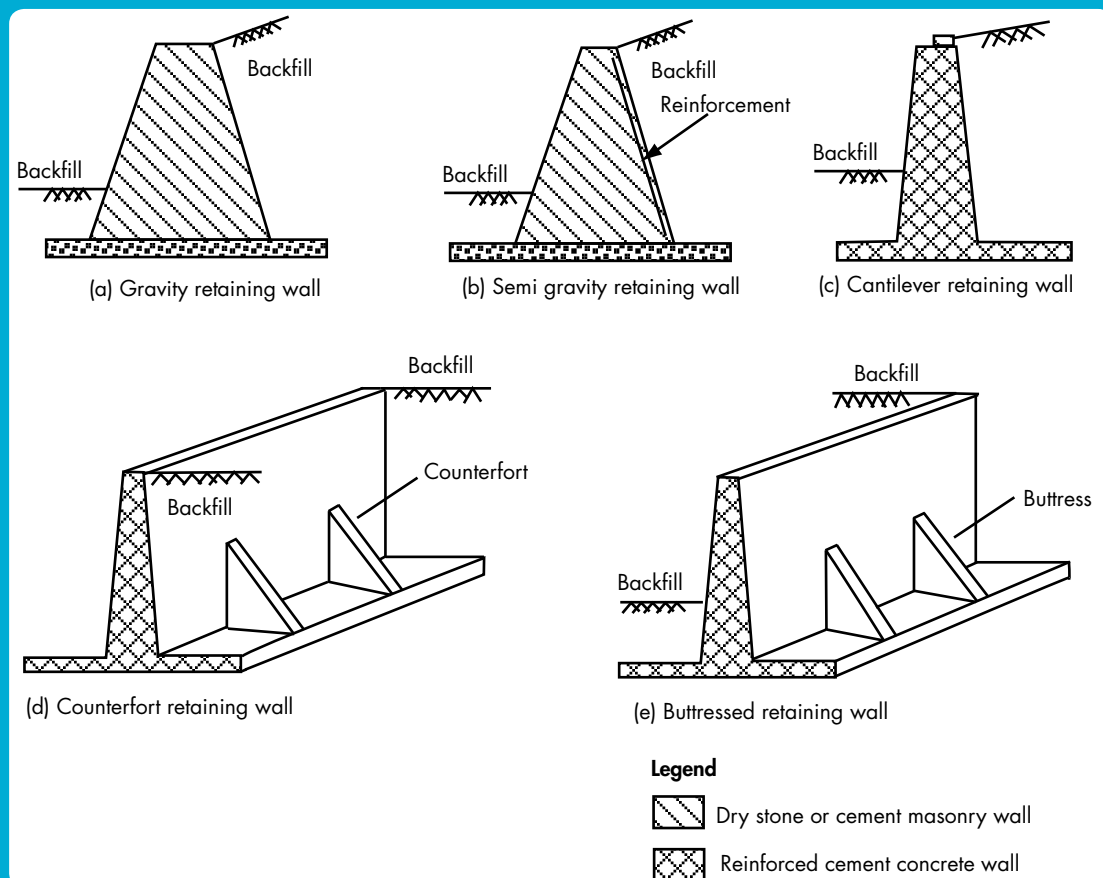

### Box 11: Designing a retaining wall

The design of a retaining wall mainly consists of the estimation of the load and active pressure acting on the structure and the design of the structure to withstand this load and pressure. The forces acting on the wall are the lateral pressure and the self weight of the wall. The self weight of the wall is responsible for supporting the lateral earth pressure.

Consider as an example the case of a gravity retaining wall as shown in Figure 34. The wall is supporting the soil mass with no surcharge.

The first step is to estimate the pressure of the earth on the wall. Rankine's formula can be used to calculate the pressure as follows:

$$P = \frac{\gamma s H^2 (1 - \sin\phi)}{2(1 + \sin\phi)}$$

where

$P$  = pressure in  $\text{kg/m}^2$  (the pressure acts at  $H/3$  above the base [DSCWM 2005]),

$H$  = height of the wall in metres,

$\gamma s$  = density of the soil in  $\text{kg/m}^3$ , and

$\phi$  = angle of earth in degrees.

The weight of the wall per metre length is given by:

$$W = \frac{(a+b) \times H \times \gamma m}{2}$$

where

$W$  = weight of wall per metre length in  $\text{kg/m}$  (the weight acts at a distance  $X$  from the face  $BC$ ),

$\gamma m$  = density of wall material in  $\text{kg/m}^3$ ,

$a$  = top width of retaining wall in metres, and

$b$  = bottom width of retaining wall metres.

For the structure to be in equilibrium, the following conditions must be satisfied:

- The algebraic sum of all the vertical forces must be zero, i.e.,  $\sum V = 0$ ;
- The algebraic sum of all the horizontal forces must be zero, i.e.,  $\sum H = 0$ ; and
- The moment of all forces acting on the wall about any point must be zero (to prevent it overturning), i.e.,  $\sum M = 0$ .

Let  $R_v$  and  $R_h$  be the vertical and horizontal reactions at the point of application of the resultant force  $R$  on the base of the wall.

For  $\sum V = 0$ ,  $W = R_v$ .

For  $\sum H = 0$ ,  $P = R_h$ .

For  $\sum M = 0$ , taking the moment about  $B$ ,

$$P \times H/3 + W \times X = R_h (X + Z),$$

where

$Z$  = the shift, i.e.,  $EF$ .

Since  $R_h = W$ ,

$$P \times H/3 + W \times X = W(X + Z).$$

On simplification,

$$Z = \frac{P \times H}{3 \times W}.$$

If  $O$  is the middle point of base  $AB$ , then

$$\text{eccentricity } (e) = OF = BF - BO = X + EF - b/2$$

$$= X + Z - b/2.$$

After calculating the lateral pressure acting on the wall ( $P$ ), self weight of the wall ( $W$ ), point of application of lateral pressure force, centre of gravity of the wall, and eccentricity, the section can be checked for stability.

**Figure 34: Gravity retaining wall showing the dimensions (black arrows) and the forces acting on it (blue arrows)**

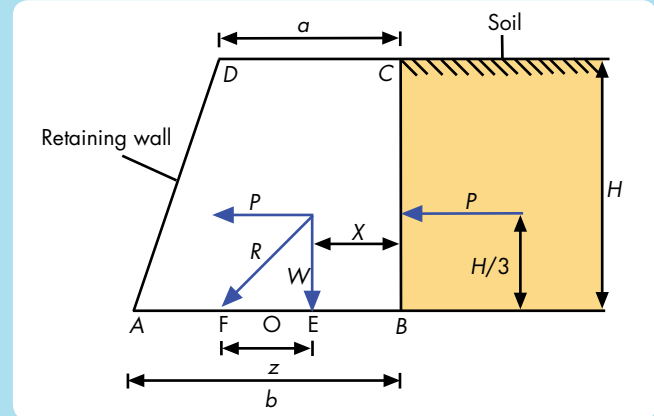



of a gravity retaining wall can be reduced if a small amount of reinforcement is provided near the back face (Figure 33b).

**Cantilever retaining wall.** A cantilever retaining wall has a relatively thin stem, usually made of concrete reinforced with steel to resist the tensile force (Figure 33c). The width of the footing is very important as it is designed to resist the sliding forces which the earth exerts upon the wall. The wall requires significant steel reinforcing in both the footer and the wall structures. The steel should extend from within the footer up into the wall so that the two pieces become one integral unit. This type of wall is generally economical up to a height of 6–8 m.

**Counterfort retaining wall.** A counterfort retaining wall is similar to a cantilever retaining wall, but further supported by additional thin triangular shaped walls, or counterforts, built at right angles to the main trend of the wall. The counterforts are spaced at regular intervals along the wall and connect the back of the wall to the top of the footing (Figure 33d). The footing, retaining wall, and support walls must be tied to each other with reinforcing steel. The counterforts reduce the shear force and bending moments in the stem and the base slab and add strength to the retaining wall. They are hidden within the earthen or gravel backfill of the wall. Counterfort retaining walls are economical at heights of more than 6–8 m.

**Buttressed retaining wall.** Buttressed and counterfort retaining walls are similar, with the main difference that in buttressed walls the vertical brackets are provided in front of the wall (Figure 33e). The buttresses add strength and help to stabilize the overall wall system. Depending upon the overall length of the main wall, several buttresses can be constructed at regular intervals.

## Types based on construction material

**Dry stone masonry.** Dry stone masonry walls are usually the cheapest wall structures and are suitable for heights up to 3–4 m. A skilled mason, suitable stones, and bonding of stones with keystones are required to make a good quality wall. In general, the width to height ratio varies from 1:1–0.6:1 for walls with heights of 1–4 m.

**Gabion wall.** A gabion is a heavy duty basket-like structure made in the shape of a box from welded or twisted galvanized iron wire mesh, divided by wire diaphragms into cells, and filled with heavy material (typically rocks or broken concrete) that cannot escape through the mesh openings. Gabions are generally used as construction blocks, and are tied together with galvanized iron binding wire to form larger structures. Gabion walls are constructed using gabion boxes of various sizes stacked next to and on top of each other before tying. Good quality stone should be used to fill the boxes, with dimensions preferably not less than 10 cm, or at least greater than the mesh size. Stones should be packed as tight as possible to increase the density of the gabion wall. The gabion structures are flexible and provide good drainage due to the dry stone packing.

**Cement masonry wall.** Cement masonry walls are constructed using good quality stones with cement sand mortar. These walls are rigid and designed as gravity structures with a base width varying from 0.5–0.75 times the wall height. The foundation must be on firm, risk-free ground. Weep holes of at least 75 mm diameter should be included every 2 x 2 m<sup>2</sup> in a staggered pattern for drainage. As these walls are rigid and impermeable, they are not appropriate for construction to hold wet colluvial slopes or where ground movement is expected.

**Composite masonry wall.** Composite masonry walls are similar to cement masonry walls except that they have panels of dry stone masonry of about 0.6–1 m square forming a grid on the face and separated by 0.5 m strips of cement masonry. They are stronger than dry masonry walls but retain the advantage of having relatively good water drainage.

**Cement concrete wall.** Cantilever, counterfort, and buttressed retaining walls are constructed with reinforced cement concrete. The reinforced steel in the wall takes up the tensile stress that the wall is exposed to. The amount of steel required is calculated by analysing the load on the wall.

**Crib wall.** A crib wall is a box-type structure built from interlocking struts of timber, precast reinforced concrete, steel, or other material, and is usually infilled with soil or stone. The whole unit acts as a gravity wall. Due to its construction without fixed joints, and the segmented nature of the elements, crib walls are flexible and thus to some extent resist differential settlement and deformation.

## Safety of a retaining wall

Retaining structures can fail for a variety of reasons. The major types of failure are shown graphically in Figure 35. The measures used to protect a wall against these different types of failure are summarized in the following sections.

**Safety against sliding.** Retaining walls should be able to resist the sliding force exerted by the lateral pressure ( $P$ ) which tends to cause slide along the plane below the bottom slab, which is resisted by the shear force developed between the bottom slab and the ground (frictional resistance). If  $\mu$  is the coefficient of friction between the base of the wall and the soil, the maximum frictional resistance is equal to  $\mu W$ . Thus for stability against sliding,  $P$  must never exceed  $\mu W$ . The factor of safety ( $F$ ) is given by

$$F = \mu W/P.$$

A minimum factor of safety of 1.5 is generally recommended.

**Safety against overturning.** Retaining walls should be able to resist the overturning moment exerted by the horizontal component of the lateral earth pressure. The resisting moment is composed of the vertical component of the lateral earth pressure and the self weight.

The section is in equilibrium under the action of four forces (Figure 34):

- the horizontal pressure of the earth ( $P$ ) acting at  $H/3$  from the base of the wall;
- the weight of the wall ( $W$ ) acting at a distance  $X$  from the wall face  $BC$ ;
- the vertical component ( $R_v$ ) equal to  $W$  and acting at  $E$ ; and
- the horizontal component ( $R_H$ ) equal to  $P$  and resulting from the frictional resistance between the wall body and the ground.

The section can overturn about the point  $A$ . As long as the resultant  $R$  touches the base, the section cannot overturn. If  $R$  touches the base at  $A$ , the section is on the point of overturning, and if it falls outside the base, the section will

Figure 35: Modes of failure of retaining structures

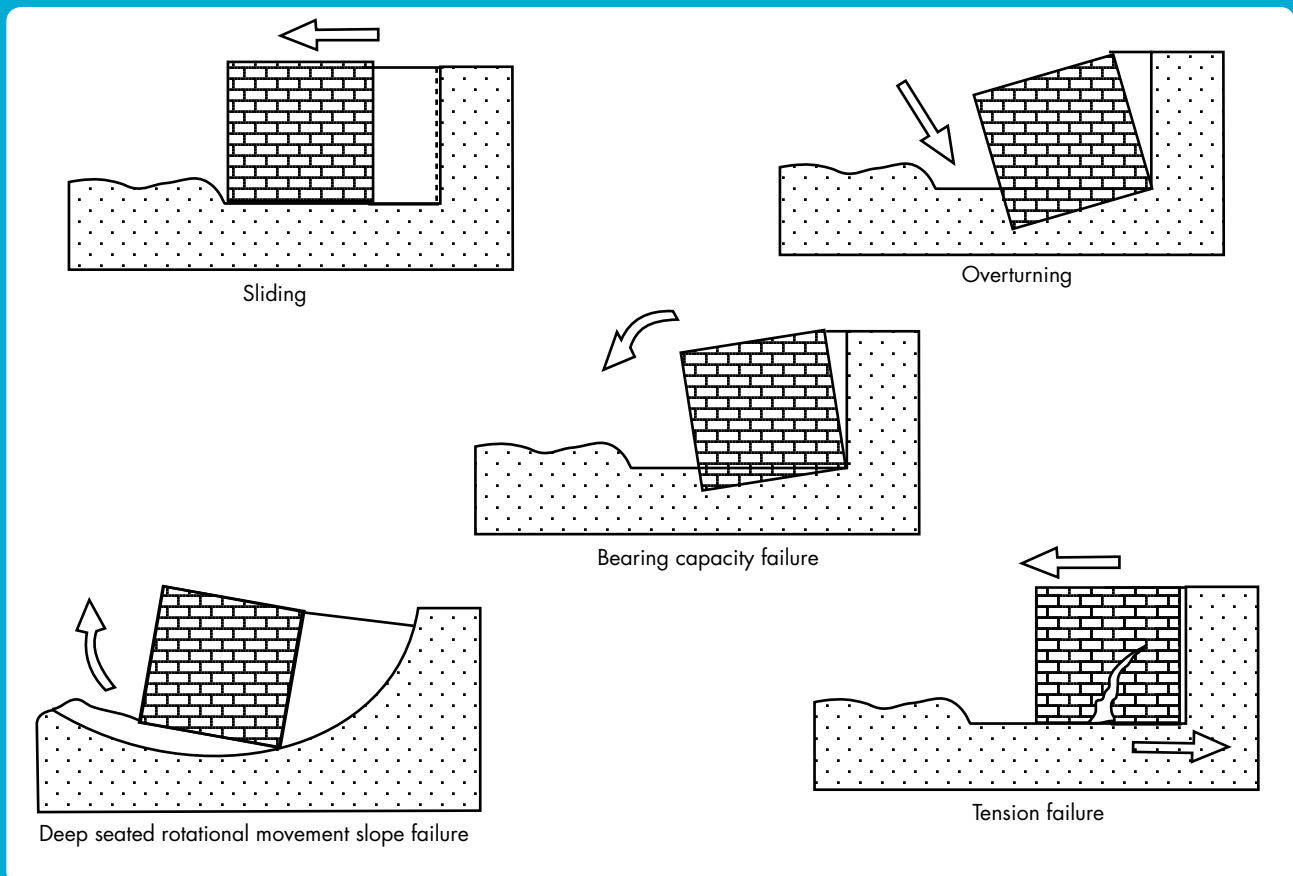

overturn. Hence, the limiting value is when  $F$  coincides with  $A$ , i.e.,  $EF = EA$ , when the balancing moment will have a value equal to  $W \times EA$ .

$$\text{Factor of safety} = \frac{\text{Limiting balancing moment}}{\text{Overturning moment}} = \frac{W \times EA}{P \times H/3}$$

The recommended factor of safety against overturning is usually 1.5–2.0.

**Safety against bearing capacity failure.** The supporting strength of soil or rock is referred to as its bearing capacity. The maximum pressure which soil can carry safely without risk of shear failure is the safe bearing capacity. In order to avoid bearing capacity failure of the soil at the base, the maximum comprehensive stress acting normal to the base must be less than the allowable bearing capacity of the soil. The maximum comprehensive stress normal to the base must also be less than the maximum comprehensive stress for the masonry to avoid crushing the masonry at the base.

$$\text{Factor of safety} = \frac{\text{Allowable bearing pressure or permissible comprehensive stress for the masonry}}{\text{Maximum comprehensive stress at the base of wall}}$$

A factor of safety of 3 is recommended for safety against bearing capacity failure.

**Safety against tension failure.** There should be no tension at the base of the wall. To avoid tension within the structure, the eccentricity ( $e$ ) should be not more than  $b/6$  on either side of middle of the base, i.e., at the point  $O$ . Under such conditions, the resultant,  $R$  must be within the middle third of the base width.

In designing a gravity type retaining wall, a trial section is chosen and checked for all the stability conditions mentioned above. If the stability checks yield unsatisfactory results, the section is changed and rechecked. Table 7 shows the design dimensions for a typical retaining wall structure.

**Table 7: Typical retaining wall design specifications**

Type	Dry stone masonry	Composite masonry	Cement masonry	Gabion	
				Low	High
Top width	0.6–1.0 m	0.6–1.0 m	0.5–1.0 m	1.0 m	1–2 m
Base width	0.5–0.7 $H$	0.6–0.65 $H$	0.5–0.65 $H$	0.6–0.75 $H$	0.55–0.65 $H$
Front batter	vertical	varies	10:1	6:1	6:1
Back batter	varies	vertical	varies	varies	varies
Inward dip of foundation	1:3	1:3	horizontal or 1:6	1:6	1:6
Foundation depth below drain	0.5 m	0.5–1 m	0.5–1 m	0.5 m	1 m
Height range ( $H$ )	1–6 m	6–8 m	1–10 m	1–6 m	6–10 m
Hill slope	<35°	20°	35–60°	35–60°	35–60°
Toe protection in case of soft rock/soil	Boulder pitching				
General	Set stones along foundation bed. Use long bond stones.	Cement 50 cm thick, masonry bands at 3 m centre to centre	Make weep holes of 75 mm diameter at 1–2 m c/c. Provide 50 cm rubble backing for drainage.	Hand pack stones. Select block shapes in preference to flat. Specify maximum/minimum stone size. Do not use weathered stone. Compact granular backfill in a layer (<15 cm).	
	Foundation to be stepped up if rock encountered All walls require durable rock filling of small to medium size. Drainage of wall bases not shown				
Application	Least durable		Most durable	Can adjust to settlement and slope movement	
	Non-ductile structures, susceptible to earthquake damage			Very flexible structures	

## Drop Structures

Drop structures, also known as grade control structures, are structures placed at intervals along a channel reach to change a continuous steep slope into a series of gentle slopes and vertical (or steep and roughened) drops, like a series of steps. They control erosion and river channel degradation by reducing the slope of the channel and preventing the development of high erosive flow velocities, and allow water to drop safely from one level to another without gouging out gullies. They can also help to control flooding and trap the sediment moving with runoff water.

Drop structures include sills, weirs, chute spillways, drop pipes, and check dams. A weir allows water to run over the edge like a miniature waterfall, dropping down onto a concrete apron. The apron absorbs the impact of the falling water and then the water streams to an outlet. When the drop in grade is more dramatic, a chute can be used to prevent severe erosion. As the name implies, water moves down a chute made of concrete or lined with rocks or concrete blocks. Like chutes, pipes are effective in handling water when the drop in grade is dramatic. They are designed to carry water through or under an earth embankment to a lower elevation. With a drop inlet, water drops down into the inlet and then flows through the pipe. Because of the high energies that must be dissipated, pre-formed scour holes or plunge pools may be required below these structures.

In steep hill and mountain areas, the most common drop structures are check dams, which are used to control gully erosion. Check dams are described in more detail in the following section. Drop structures are also used to reduce the effective slope below the upper limit for a grassed waterway. Weirs and sills are more common downstream as river training measures.

Drop structures can be made of concrete, timber, sloping riprap sills, and soil-cement or gabions. Drop structures made from timber or logs are more appropriate in small streams and gullies.

EC (1997) contains more details on the implementation of some of these structures.

### Check dams

Check dams are small low drop structures built across a gully or channel to prevent it from deepening further. These small dams decrease the slope gradient and reduce the velocity of water flow and the erosive power of the runoff. They also promote the deposition of eroded materials to further stabilize the gully or channel.

Gully plugging using check dams, accompanied by planting between the dams to stabilize the channel, can be one of the most effective ways to conserve soil and water and rehabilitate land degraded by gullies (Guedel 2008). The effectiveness of different check dams depends upon the design, location, and construction materials. Figure 36 shows an example of check dams constructed to reduce gully erosion.

Check dams can be constructed from a wide range of materials including rock, wood, bamboo, gravel bags, sand bags, concrete, masonry, and fibre rolls. The characteristics, advantages, and disadvantages of some major different types of check dams are summarized in Table 8. Two different types are shown in Figure 37.

Details on check dam design are given in Box 12, and considerations for their construction are given in Box 13.

**Figure 36: Gully erosion (top) and check dam treatment (bottom) in Dahachowk, Kathmandu, Nepal**



Source: DWIDP

Figure 37: Gabion check dam (left) and masonry check dam (right)



Source: DWIDP

Source: Peng Huang

Table 8: Characteristics of some common types of check dam

Type of check dam	General characteristics	Advantages	Disadvantages
Brushwood	Made of wooden poles and brush Suitable for small gullies 1–2 m deep Low cost where materials are locally available	Simple Uses local materials Low cost If roots and shoots develop, they can form a long-term barrier	Least permanent of all types if not rooted Takes a long time for the dams to develop roots and become established
Loose stone	Made of loose stone or rock Stability and strength depends on the size of rocks and quality of the construction Commonly used in gully control where boulders or rocks are abundant	Uses local materials Simple Low cost (where stones are abundantly available)	If not made properly or stones are too small, they can be washed away
Boulder	Made of big boulders or rocks Stability and strength depends on the size of the boulders or rocks and quality of construction Commonly used in gully control where boulders or rocks are abundant	Uses local materials Simple Low cost If properly made, are almost permanent and durable	Transportation of big boulders is difficult (if not available upslope of the site) If large voids are not properly filled they, may create water jets, which can be destructive if directed towards the bank
Gabion	Made with wire gabions of different sizes filled with stones Flexible Preferred where big boulders are not available	Flexible and permeable Suitable where the land mass is unstable Economical compared to other solid structures	More expensive than loose stone or boulder structures The gabions have to be brought from outside which increases the cost Need skilled labour for construction
Masonry	Made of cement masonry or concrete Generally only used to protect important infrastructure such as roads and buildings	Permanent solid structure Good appearance	High cost Materials not locally available (cement, rods) Need more engineering design, and skilled labour for construction

Source: DSCWM 2004

## Box 12: Designing a check dam

The discharge rate through the channel must be calculated first. The hydraulic element of the design, especially the spillway section, is also very important as any fault in the hydraulic design can reduce the life of the structure.

### Spacing

The spacing between dams is an important factor in the design (Figure 38). The space between consecutive check dams is selected to obtain the desired gradient between the bottom of the upper dam and the top of the lower dam – known as the compensation gradient. The spacing depends on the slope of the original waterway, the compensation gradient, and the effective height of the dams (DSCWM 2005). It is given by

$$d = h \times \frac{100}{S_0 - S_e}$$

where

$d$  = spacing between two successive check dams (horizontal distance),

$h$  = height of the check dams up to the notch,

$S_0$  = existing slope of bed in per cent, and

$S_e$  = stabilizing slope of bed in per cent (usually 3–5%).

The number of check dams ( $N$ ) is calculated as follows (DSCWM 2005):

$$N = \frac{a - b}{H}$$

where

$a$  = total vertical distance between the first and the last check dam in that portion of the gully or torrent,

$b$  = total vertical distance calculated according to the compensation gradient for that portion of the gully, and

$H$  = average height of the dams.

### Runoff estimation

Various methods are used to estimate the runoff rate. The rational formula is the simplest method for determining peak discharge from drainage basin runoff, but the calculation is only possible if the rainfall intensity, area of watershed, and runoff coefficient are known (DSCWM 2004).

$$Q = \frac{C \times I_{tc} \times A}{360}$$

where

$Q$  = rate of runoff in  $m^3/s$ ,

$I_{tc}$  = rainfall intensity in mm/hr for a designed frequency and a duration equal to the time of concentration ( $t_c$ ),

$A$  = area of watershed in ha, and

$C$  = dimensionless runoff coefficient.

Figure 38: Check dam spacing

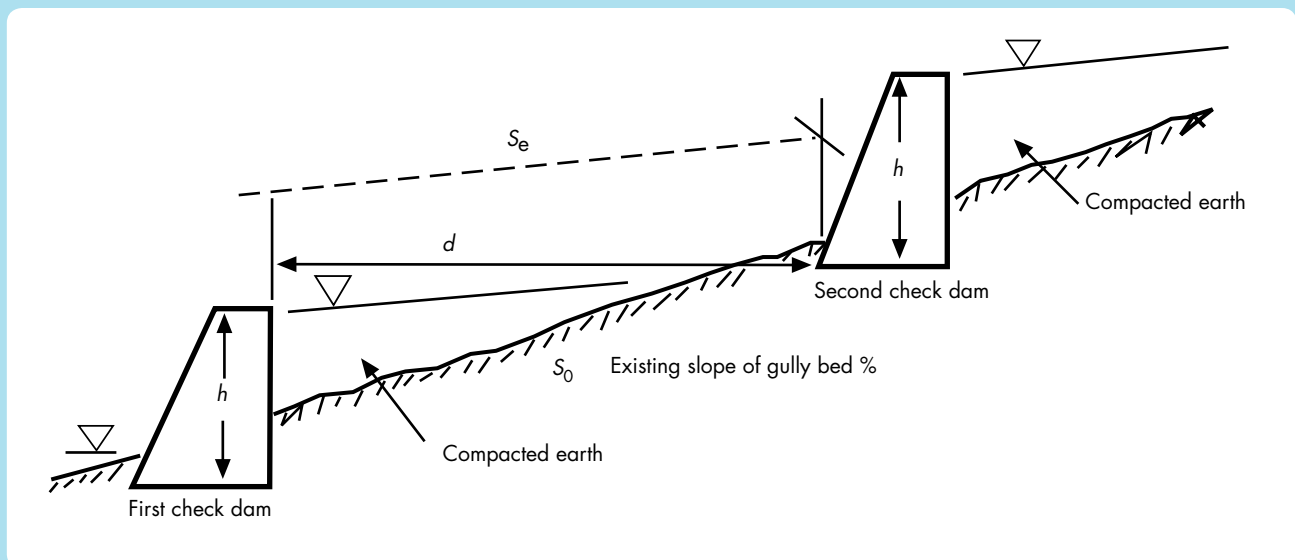



The time of concentration (gathering time) is calculated from

$$t_c = \frac{L^{1.15}}{15 \times H^{0.38}}$$

where

$t_c$  = time of concentration (gathering time) in hours,

$L$  = length of the watershed along the main stream from the outlet to the most distant ridge in km, and

$H$  = difference in elevation between the watershed outlet and the most distant ridge in km.

Note: The rational formula can only be used when a rainfall intensity ( $I_{tc}$ ) map of the given area is available with frequencies of 5, 10, 25, 50, and 100 years. If no is map available, the following discharge formulae must be used instead (Kresnik's run-off equation and Manning's velocity or runoff rate formula).

The Kresnik run-off equation is

$$Q_{\max} = C \times A^{1/2},$$

where

$Q_{\max}$  = maximum permissible discharge in  $m^3/s$ ,

$A$  = catchment area of the gully above the proposed check dam in  $km^2$ , and

$C$  = coefficient ranging from 0.6–2.0 (depending on land use type).

Note: the Kresnik equation gives the best results for gullies with catchment areas of less than 20 ha. It can also be used in torrent control for catchments up to 300 ha.

The Manning formula estimates the runoff rate from the river bed characteristics:

$$V = \frac{1}{n} \times R^{2/3} \times S^{1/2}$$

where

$V$  = velocity of flowing water (m/s),

$n$  = roughness coefficient of the channel (for gully channels,  $n$  can be set at 0.025),

$S$  = gradient of the gulley channel (%),

$R$  = hydraulic radius (wetted area divided by wetted perimeter) (m) or  $R = A/P$ ,

$A$  = cross-sectional area of the river ( $m^2$ ), and

$P$  = wet surface of the river (m).

Note, however, that this formula is not accurate for rivers with a high bed load or with mudflow, because this changes the specific weight of the water.

The notch of the check dam, i.e., the spillway section, is designed to allow the spillway to accommodate peak runoff. The dimensions are calculated from

$$Q = C \times L \times D^{2/3},$$

where

$Q$  = maximum discharge of the gully catchment at the proposed check dam point ( $m^3/s$ ),

$C$  = coefficient, 3.0 for loose rock, boulder, log, and brushwood dams; 1.8 for gabion and cement masonry dams,

$L$  = length of spillway (m), and

$D$  = depth of spillway (m).

### Foundation depth

The check dams are built on a foundation which anchors them into the ground to increase stability and ensure that they do not collapse or overturn when the peak flow or run off occurs or the dams are silted up. The following should be taken into account in the design and construction of the foundation:

- The bottom of the foundation should lie below the scour level.
- In erodible strata, if  $D$  is the anticipated maximum depth of scour below the designed highest flood level, including possible concentration of flow, the minimum depth of foundation below the highest flood level should be  $1.33D$ .
- The scour depth should be taken from the expected bed level after siltation of the lower check dam and establishment of the new bed gradient, due to the reduced bed load after the erosion control.
- As a rule of thumb, take the foundation to be 1 m.

### Scour depth

The safety of the check dams is mostly endangered by scouring. Scour occurs when the bed velocity of the stream reaches the velocity that can move the particles of the bed material. The scouring action of the current is not uniform; it is deeper at the obstruction and at bends.

The scour depth is calculated from Schocklitch's formula (DSCWM 2004):

$$\text{Scour depth } (D_s) = (4.75 \times h^{0.2} \times q^{0.57}) / dm^{0.35}$$

where

$D_s$  = scour depth in m below water level,

$dm$  = grain diameter in mm, determined on the basis that 90% of the bed material is smaller than  $dm$ ,

$h$  = water level difference in m above and below the check dam, and

$q$  = runoff in  $m^3/m$  width of spillway.

The breadth of the scour hole is calculated as  $1.5 \times$  length of the notch.

The length of the scour hole or apron is calculated as  $4 \times (0.467 \times q^{2/3})^{1.5} \times h^{0.5}$ .

### General design considerations

Check dams are designed for safety against overturning, safety against sliding, and safety against the bearing pressure on the foundation soil. Table 9 summarizes the suggested general design specifications for different types of check dam.

**Table 9: General specifications for check dams**

Dam type	Maximum effective height	Minimum foundation depth	Thickness of dam at spillway level	Slope of the downstream face of the dam	Slope of the upstream face of the dam	Thickness of the base of the dam
Brushwood	1 m from ground level	0.75–1 m	–	–	–	–
Loose stone	1.0 m	0.5 m	0.5–0.7 m	20% (1:1/5)	vertical	calculated accordingly
Boulder	2.0 m	half of effective height	preferably 1.0	30% (1:3)	vertical	calculated accordingly
Gabion	may vary (recommended not more than 5.0 m)	half of effective height	>1 m	20% sloped, stepped, or vertical	stepped or vertical	calculated accordingly

Note: Use of these dimensions means no stability test is needed against overturning, collapsing, or sliding. However, the size of the spillway needs to be calculated according to the maximum discharge of the gully watershed area.

Source: DSCWM 2004 (based on Geyik 1986)

### Box 13: Basic considerations for check dam construction

The function of check dams is to reduce the gradient and minimize the hydraulic energy of the flowing water. The flow velocity, and thus the erosion capacity, is controlled by the size of the dams and spillways. The following should be considered when constructing check dams.

- Construction should normally start at the downstream end of the active section of a gully.
- The top of the check dam should be below the level of the adjacent land to prevent spillover of flood to either side of the gully.
- The height of the outflow should be no more than 1 m. The lower the check dam, the smaller the risk of collapse and overflow to the side and of the need for repair. The ideal height of the spillway is often 0.5–0.6 m. It is better to build two low dams in a cascade than one high dam.
- The check dam should be made lower at the centre to form a spillway. The spillway will draw the stream to the middle, thus hindering erosion of the gully sides.
- The check dam should extend into the gully floor and the sides of the gully. This 'keying in' will help prevent erosion scouring and tunnelling under or around the check dam. The depth of the keying in depends on the local soil conditions, but should usually be between 0.3 and 1.0 m, more when the sides of the gully are unstable.
- An apron should be constructed in the gully area immediately downstream of the check dam to protect it from the erosive forces of the falling water. Without an apron, the check dam will be undercut and will eventually collapse. The apron should be 1.5–2 times longer than the height of the check dam depending on the slope of the gully. The greater the slope, the greater should be the length of the apron. Both the floor and the sides, from the top of the spillway to the downstream end of the apron, should be protected by piling stones.

## Sabo Dams

(adapted from Ikeda 2004)

Sabo dams are a common measure to limit debris flows. They are in some ways similar to check dams, but they are intended to limit debris flow rather than runoff velocity. The word sabo comes from Japanese and means soil conservation (sa means soil and bo means conservation); sabo dams are a Japanese technology that is now becoming popular beyond Japan. Sabo dams are relatively small structures built across the river bed in upstream areas in the form of a cross dike. They look like a normal small dam, except that they have a lower 'open' section at the centre which allows debris to pass through during normal conditions but prevents large-scale debris flow during flash floods. Sabo dams built in the upstream areas of mountain streams accumulate sediment and suppress the production and flow of sediment. Those built at the exits of valleys work as a direct barrier to a debris flow which has occurred. A sabo dam with slits is particularly effective in capturing a debris flow because it has a larger capacity of sand pool under normal conditions.

Sabo dams are usually constructed using masonry, concrete, reinforced concrete, or steel cribs according to the conditions in the planned area (Figure 39). The main functions of a sabo dam are to

- reduce erosion of the river bed and bank;
- trap sediment discharge;
- control sediment discharge;
- grade the effect of sediment; and
- reduce the energy of debris flows.

Based on their purpose and the way they function, sabo dams are classified into four types:

- check consolidation dam;
- river bed erosion control dam;
- river bed sediment runoff control dam; and
- debris flow control dam.

Sabo dam design is described in Box 14.

## Gully Control

Gullies are a highly visible form of soil erosion created by running water. They are deep-sided water courses, metres to tens of metres in depth and width, gouged out by surface water flow. Gully formation can start with the formation of rills by surface water flowing down a slope, especially where soil is exposed (Figure 41). Water flow is concentrated and accelerated down the rills, leading to increased erosion and eventually formation of a full gully. Gullies channel and accelerate runoff, and thus contribute to flood and flash flood development, as well as causing damage to the surrounding area and infrastructure, reducing the productivity of farmland, and contributing to sediment flow and sedimentation of downstream lands, streams, channels, and reservoirs (DSCWM 2004).

The major causes of gully erosion are:

- erosion in the catchment,
- channel erosion by unmanaged runoff resulting in downward or sideways scoring,
- steep unprotected slopes and drainage channels,
- gully head expansion, and
- side slope failure due to toe cutting of the gully channel embankment (DSCWM 2004).

Figure 39: Debris flow controlled by a sabo dam

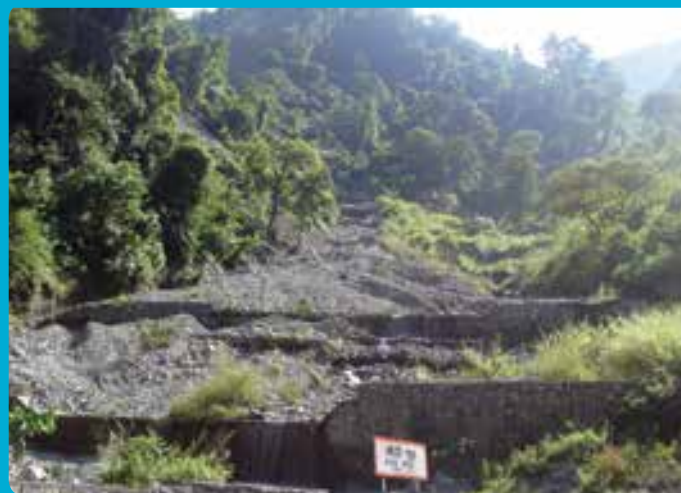

Source: Sundar Kumar Rai

## Box 14: Designing a sabo dam

Sabo structures must be designed according to the intended function and purpose and should be stable enough to withstand all the expected design forces. The main steps in designing a sabo dam are as follows:

- determination of general design considerations,
- determination of design parameters of debris flow,
- design of open section,
- design of dam body,
- design of dam foundation, and
- design of other appurtenances.

The basic principles of design are summarized in the following. More details can be found in Ikeda (2004).

### General considerations

The location and height of the dam are chosen according to the dam's purpose. The height may also be restricted by the geological and topographical conditions at the proposed location. The dam should be located on stable ground, if possible on firm bedrock, as dams are easily destroyed by slope failure if constructed in an unstable location. Ideally the dam should be located in a stable narrow section of the riverbed to give the highest stability and most cost effective construction. The height of the dam is usually reduced if it has to be built on a gravel base.

### Design parameters of the debris flow

Before designing the dam, it is important to determine the design parameters of the debris flow. The fluid dynamic force of the debris flow, peak debris flow discharge, velocity of the debris flow and maximum water stage, height of the debris flow, and density of the debris flow should all be calculated or estimated.

### Designing the open section

The topography and geological features upstream and downstream of the sabo dam should be taken into consideration when designing the open section. The axis of the sabo dam is placed at right angles to the direction of the river with the open section at the centre of the river course. The open section should be at least 3 m wide, and the final width also depends on the width of the stream bed. The height of the open section is determined from the design depth of the opening, the freeboard, and the maximum diameter of boulders expected in the debris flow.

A 50% sediment discharge is added to the actual flood discharge to obtain the design discharge.

$$Q = (1+0.5) Q_1,$$

where

$Q$  = design discharge, and

$Q_1$  = actual flood discharge.

### Design of the dam body and foundation

The design of the body of the dam is based mainly on a stability analysis. The main forces acting on the dam body are overturning, sliding, and bearing resistance of the foundation. The debris flow hydraulic forces are calculated by assuming a unit weight of debris-laden water of 11.8 kN/m<sup>3</sup>.

The dam foundation is determined by considering the bearing capacity and the nature of the underlying foundation material (soil or rock). Foundation treatment such as construction of a cut-off wall or slurry wall is recommended when the material is poor. A cut-off wall should be constructed at the toe of the dam to prevent damage by scouring.

The design loads that must be considered for a gravity type sabo dam are:

- hydraulic static pressure,
- sedimentation pressure,
- uplift pressure,
- seismic inertia force, and
- hydrodynamic pressure during an earthquake.

### Sub-sabo dam

A sub-sabo dam can be constructed when the main dam height is high or the overflow depth is deep (Figure 40). The main function of a sub-sabo dam is to reduce the overflow energy of the mass overflowing the dam. Selection of the position of the sabo dam and sub-sabo dam should be based on the extent of sedimentation and designed to prevent sediment-related disaster.

The desirable distance between the main dam and sub dam can be calculated using the following empirical formula.

$$L = \beta \times (H_1 + h_3),$$

where

$L$  = distance between the main dam and sub dam,

$\beta$  = 1.5~2.0 (value depends on height of sabo dam at overflow section and width of crest),

$H_1$  = height of the main dam (front apron) above the bedrock (m), and

$h_3$  = overflow depth of the main dam (m).

**Figure 40: Main sabo dam and sub-sabo dam**

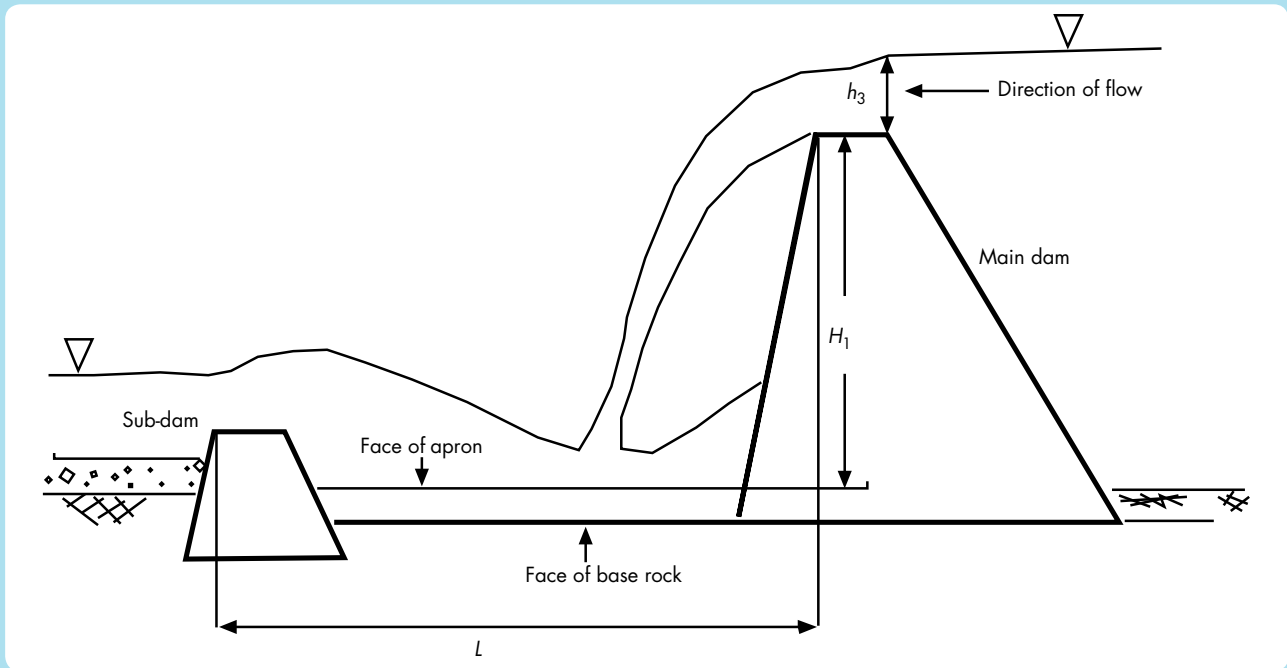

**Figure 41: Gully formation**



Source: ICIMOD 2008



Gully expansion mainly results from headward erosion by concentrated surface water flow. As a result, the gullies often expand upslope.

Ideally, land protection measures should be implemented across a catchment to help prevent gully formation. Once a gully is formed, however, remediation treatment should be undertaken to prevent further expansion of the gully and to slow the flow of runoff downstream. The main approaches are summarized as follows.

### Improvement of the catchment above the gully

The techniques for improvement of the catchment above a gully are the same as those recommended to prevent gully formation. Essentially, they include all the methods recommended for controlling surface runoff by increasing infiltration and trapping moisture, as well as soil protection measures and slope stabilization. Measures include bioengineering approaches such as contour farming, strip farming, mulching, and afforestation, as well as physical measures such as bunding, terracing, levelling, and trenching, and building structures for diversion of surface runoff such as grassed waterways and weirs. Details of some of these are given in earlier sections.

### Stabilization of the gully head

It is important to stabilize the gully head and prevent it from advancing. This can be done by diverting the runoff to stop it from entering the gully, or by allowing the runoff from upstream to enter the gully safely by installing drop structures.

### Diversion of surface water above the gully head

In some cases, diverting excess runoff away from the gully head can control gully erosion. For this, diversion drains are constructed above the gully head to divert the excess runoff away from the gully.

### Check dams

The major approach used to treat a gully is to build check dams to reduce the flow velocity down the gully. This method is described in detail in earlier sections.

### Integrated measures for gully stabilization and treatment

Gullies are treated using a range of the bioengineering and construction measures outlined above in the watershed above the gully head, around the gully head, and down the gully. The aim is to prevent further deepening and widening of the gully and to control the flow velocity. Table 10 summarizes the different remediation techniques recommended for different depth classes of gully. Table 11 summarizes the criteria for the selection of different control measures along different parts of a gully (Geyik 1986).

**Table 10: Remediation techniques for different sizes of gully**

Type	Depth (m)	Recommended remediation techniques	
		Waterway	Gully area
Rill	<0.30	Fascines (community land), conservation tillage (agricultural land)	Planting
Small gully	0.3–1	Palisades, brushwood, check dams	Planting/brush layering/wattling
Medium gully	1–5	Brushwood and loose stone check dams	Planting/brush layering/wattling
Large gully	5–10	Loose stone and gabion check dams	Planting/brush layering/wattling/retaining walls
Ravine	>10	Loose stone and gabion check dams	Planting/brush layering/wattling/retaining walls

Source: DSCWM 2004



**Table 11: Control measures for different parts of a gully**

Length of main gully channel	Gradient of main gully channel (%)	Catchment area of gully	Required structural measures for each portion of main gully channel
–	–	≥ 2 ha	Above gully head: Diversion ditches or channels
100 m or less (from gully head)	Various	≥ 2 ha	Up to 100 m from gully head: Brush fills, earth plugs, woven-wire, brushwood, log, and loose stone check dams.
≥ 900 m	70 or less	2–20 ha	Between 100 and 1,000 m: Boulder check dams, retaining walls between check dams if necessary; first check dam is usually gabion or cement-masonry

Note: All structural measures should be accompanied by vegetative measures (planting of tree seedlings and shrub and grass cuttings; sowing of tree, shrub, and grass seeds).

Source: Geyik 1986

## Trail Improvement

(adapted from DSCWM 2004)

Notwithstanding the advantages of road and trail construction in hill areas, it also poses considerable problems. The combination of slope instability, lack of understanding of slope dynamics, and poor planning and construction, means that roads and trails are a major source of landslides, slips, and flows in many parts of the Himalayan region, and thus contribute to the development of flash floods. Operations such as blasting and chipping create geological disturbances in the rock and soil masses of the mountain slopes. Blasting operations exert a tremendous dynamic force causing the movement of slip zones, cracks, fissures, and weak planes. In addition, poor stabilization of bared slopes and trail edges combined with heavy rainfall may lead directly to slips of different types originating along the line of the trail itself.

Trail improvement refers to the vegetative and structural measures used to protect trails from erosion and to improve them for people and livestock traffic, both during construction and in the form of remedial measures. General guidelines should be followed to ensure slope safety when designing and constructing trails and roads along steep slopes. Detailed discussion of the construction of roads and trails is beyond the scope of this manual but there are many publications available that the engineer can refer to, including the Mountain Risk Engineering Handbook published by ICIMOD in 1991 (ICIMOD 1991a,b) and various publications by the Swiss and German development agencies on 'green road' construction (GTZ and SDC 1999; SDC 2008).

Box 15 provides some basic guidelines for ensuring that trails (not roads) avoid negative impacts on slopes and runoff, together with some suggestions for remediation of specific problems.

Existing trails may start to show signs of erosion damage and instability which need to be addressed through remediation measures. Table 13 summarizes some of the improvements recommended for slopes of different steepness and condition.

**Table 13: Trail improvement on different slope**

Slope	Condition/problem	Suggested improvements
Flat	Earthen, no problem seen	Protection of the surrounding vegetation
<8°	Earthen, with rills	Rill plugging with fascines, palisades, sowing grass, construction of cross drains, levelling of the trail
<12°	Earthen, with gullying	Stone paving, construction of cross drains, planting at water disposal sites
<12°	Trail turns into a waterway	Stone paving with a concave profile and drop structures (e.g., checkdams, stepped falls), protection at water disposal sites
>12°	Earthen, with gullying	Stone steps, sowing grass, drainage management

Source: DSCWM 2004

## Box 15: Responsible trail design

### Basic design considerations

- Ideally, trails should follow a contour.
- All conservation measures required for the trail and slide slopes should be designed and implemented as a package.
- Drainage ditches should be provided at appropriate locations to guide surface runoff.
- The trail should slope outwards. A maximum cross slope of 1:20 (vertical height to horizontal length) is recommended to avoid cross ruts.
- Trails should be wider than 1.2 m.
- An average gradient of 10% is generally considered to be the maximum for comfortable walking; 15% is considered to be the maximum permissible gradient.
- Trails with gradients of less than 8° ( $\approx 14\%$ ) should be cut and levelled and sown with grass.
- Trails with gradients of 8° to 12° ( $\approx 20\%$ ) should be paved with stone.
- Stone steps should be constructed on trails with gradients above 12° ( $\approx 20\%$ ). The recommended step size is given in Table 12.
- The length of the landing (step) can be 1 m.

DSCWM (2004) gives detailed instructions for designing steps.

### Practical recommendations

- Safe disposal of trail runoff is one of the keys to the control of erosion associated with the trail.
- Trail runoff can be stored in conservation ponds for later use.
- Line the trail with stones wherever possible to reduce erosion.
- Trails can be used as waterway channels during the monsoon, make the stone pavement concave, and ensure the speed of the runoff does not exceed the resistive force of the lining material.
- On sloping sections where water may run down the line of the trail, install open, stone-lined cross drains at intervals of 10–15 m. These should lead off to a soak away area, into a well-vegetated line of natural drainage, or into a collection pond.
- Plant double lines of thorny shrubs along the side of the footpath to discourage people and animals from straying off the trail and eroding the sides.
- Plant trees, shrubs, or grass in nearby areas, improve drainage, and treat rills and gullies wherever necessary.

**Table 12: Recommended step size for different slopes**

Slope ( $\theta$ ) (degrees)	Riser height ( $R$ ) (m)	Tread length ( $T$ ) (m)
12–16	0.12	0.35
17–20	0.15	0.35
21–23	0.15	0.30
24–26	0.17	0.30
27–30	0.20	0.30
>30	0.20	0.25

Source: DSCWM 2004

# Chapter 6: Physical Methods for River Training

Flash flood mitigation in the upstream part of a catchment is aimed at reducing the occurrence of flash floods and focuses on reducing slope instability, reducing the amount and velocity of runoff, and preventing erosion. In the downstream areas, the focus is on mitigating the effects and impact of any flash flood that occurs. Some rivers are particularly prone to flash floods ('flashy rivers') and it is possible to plan mitigation interventions, even though the timing of individual flash floods cannot be predicted. This chapter looks at some structural measures in the downstream areas.

The morphology of a river is a strong determinant of flow, and can thus serve to intensify or mitigate flood waves and torrents. At the same time, when rivers flow in an alluvial plain they often become meandered or braided, and at times of flood, this morphology leads to excessive bank cutting which can destroy agricultural land and human settlements.

'River training' refers to the structural measures which are taken to improve a river and its banks. River training is an important component in the prevention and mitigation of flash floods and general flood control, as well as in other activities such as ensuring safe passage of a flood under a bridge. For flash flood mitigation, the main aim is to control the water discharge regime in the watercourse by limiting its dynamic energy, thereby controlling the morphological evolution of the watercourse (Colombo et al. 2002). River training measures also reduce sediment transportation and thus minimize bed and bank erosion. Many river training structures are implemented in combination with bioengineering techniques to lessen the negative effects on environment and landscape (see Chapter 3). There are a number of types of river training structure. The selection and design of the most appropriate structure depends largely on the site conditions.

River training structures can be classified into two main categories: transversal protection structures and longitudinal protection structures.

## Transversal Protection Structures

Transversal protection structures are installed perpendicular to the water course. They are used to lower the river gradient in order to reduce the water velocity and protect the river bed and banks from erosion. Most of the rivers in the Hindu Kush Himalayan region originate in the high mountains, where they have steep gradients giving the flow a massive erosive power. Moreover, intense rainfall and breakout events can accelerate the river flow to such an extent that the water has a significant impact on the watercourses and surrounding areas. Transversal protection structures are effective for controlling the velocity of rivers and streams and reducing the development of flash floods. The major structures likely to be useful in the region are described briefly in the following.

### Check dams

Check dams are described in detail in the previous chapter, mainly in relation to gully control. The dams used along river courses follow the same principles. They can be made of gabions, concrete, logs, bamboo, and many other materials. These dams decrease the morphological gradient of the torrent bed and reduce the water velocity during a flood event by increasing the time of concentration of the hydrographic basins and reducing the flood peak and solid transportation capacity of the river. They also help to reduce erosion and debris flow. The main purpose of check dams on rivers is to stabilize the riverbed over a long distance. Check dams generally require additional protection structures in the bed or on the banks to hinder undermining.

## Spurs

A spur, spur dyke, or groyne is a structure made to project flow from a river bank into a stream or river with the aim of deflecting the flow away from the side of the river on which the groyne is built. Two to five structures are typically placed in series along straight or convex bank lines where the flow lines are roughly parallel to the bank (McCullah and Gray 2005).

Spurs help train a river to flow along a desired course by preventing erosion of the bank and encouraging flow along a channel with a more desirable width and alignment (Julien 2002). They are used to control natural meandering at a river bend, to channel wide rivers, and to convert poorly defined streams into well defined channels. The spurs create a zone of slack flow which encourages silting up in the region of the spur to create a natural bank. They generally protect the riparian environment and often improve the pool habitat and physical diversity.

Spurs can be made from many materials including stone, for example in the form of gabions (Figure 42) or in bamboo 'cages' (Figure 43); tree trunks and branches (Figure 44); concrete; or any material that is not easily detached by the river and is strong enough to withstand the flow and the impacts of debris. They can be categorized on the basis of permeability (Figure 45), submergence (Figure 46), orientation (Figure 47), and the shape of the head (Figure 48).

Some guidelines for designing and constructing spurs are provided in Box 16.

## Sills

A sill (also called a bed sill or ground sill) is a transverse gradient control structure built across the bed of a river or stream to reduce bed or headward erosion. Sills are installed along river stretches with a medium to low morphological gradient. The purpose is similar to that of a check dam, but a sill is much lower. A sill is usually constructed together with other hydraulic structures such as bridges to prevent them from being undermined and increase their durability. Sills can be built with different shapes, for example stepped or sloping, and from a variety of materials including concrete, stone, gabions, wood, and rock. The selection of material depends on morphological and ecological factors. Sills made from wood, rock, and gabions tend to be more environmentally friendly than those made from concrete or cemented stones. The most common types of sills are the following.

**Figure 42: Gabion spurs with sandbags along the bank**



Source: Mercy Corps

**Figure 43: Low-cost bamboo and stone spurs**



Source: Deepak, DSCWM

**Figure 44: Low-cost spurs made from tree trunks and branches**



Source: Mercy Corps

Figure 45: Permeable and impermeable spurs

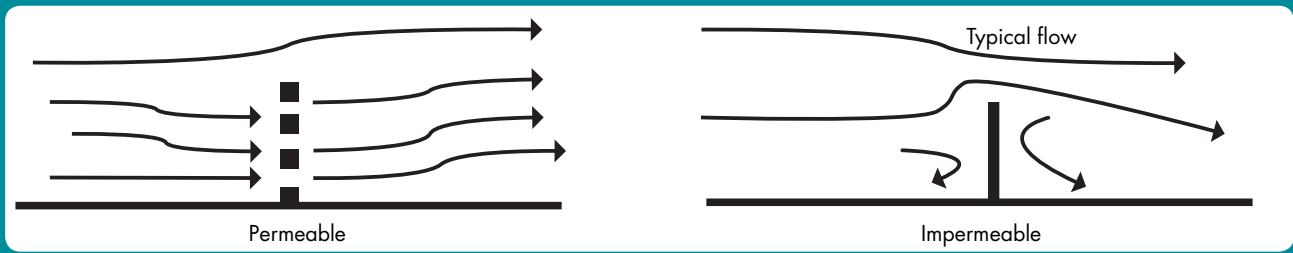

Figure 46: Submerged and non-submerged spurs

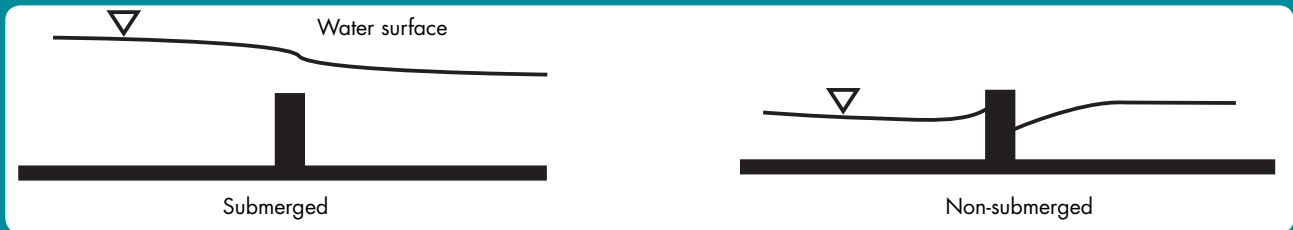

Figure 47: Different orientation of spurs

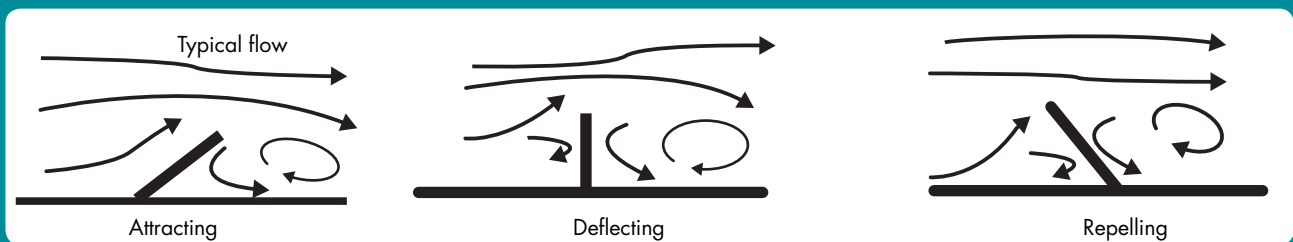
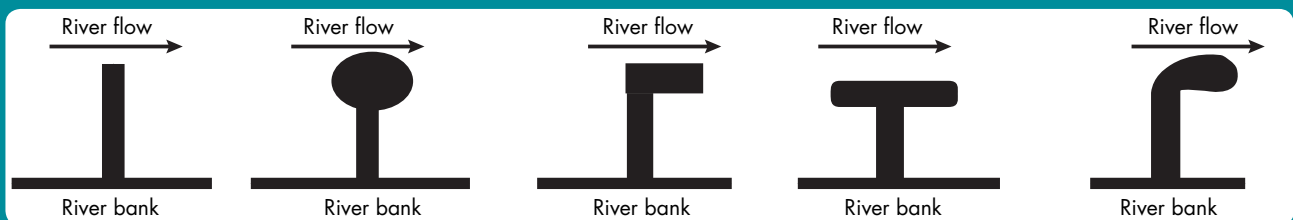

Figure 48: Different shapes of spur



**Concrete or stone sills.** Sills made of concrete or concreted stone are easy to construct and relatively common, even though the construction cost is generally higher than for other types. This type of sill can be used for a wide range of morphological conditions, and is particularly suitable for lower reaches. They are often used in combination with structures such as bridges or walls.

**Gabion sills.** Sills made with gabions can be installed under many different hydrodynamic conditions. The gabions can be filled with rock from along the river or stream bed. Gabion sills are considered environmentally less harmful than concrete sills for the natural riverine environment and ecology because of their greater width and limited height.

**Wood and rock sills.** Sills are often made of local wood and rock in the mountainous reaches of watercourses or at sites with morphological constraints. Any kind of water resistant wood can be used, the most suitable being chestnut, larch, and natural or treated resinous plants. This type of sill has a low environmental impact because of its tendency towards naturalization, which favours the ecology and environment of the watercourse.

## Box 16: General guidelines for spur design and construction

Spurs should not be used where the river is already narrow or where the alignment of the river banks cannot be modified or reduced. It is also not advisable to use spurs where the opposite bank is exposed to transverse flows, which create unacceptable erosion. In such cases continuous longitudinal protection is required (Maccaferri Australia n.d.).

The effectiveness of a spur depends on its design and location, and the resources available. The location of the upstream starting point and the downstream termination point also influence the success of spur installation. The main characteristics to be considered are summarized in the following.

### Permeability

Spurs can be permeable or impermeable (Figure 45). Impermeable spurs are built of local soil, stones, gravel, rocks, and gabions, while permeable spurs usually consist of one or several rows of timber, bamboo, or similar. An impermeable spur blocks and deflects the river flow, while a permeable spur allows water to pass through but reduces the water velocity.

### Spur height

Spurs can be designed to be higher than the water level at all times (non-submerged), or submerged during the time of floods, emerging only when the flood recedes (Figure 46). In general, submerged spurs are designed to be permeable, whereas non-submerged spurs are impermeable.

The height of non-submerged spurs should not exceed the bank height because erosion at the end of the spur in the overbank area could increase the probability of outflanking when the water level (stream stage) is high. If stream stages can be greater than or equal to the bank height, the spurs should be equal to the bank height. If flood stages are always lower than the bank height, the spurs should be designed so that overtopping will not occur at the bank (DSCWM 2005).

Submerged spurs should have a height between 1/3 and 1/2 of the water depth (Jha et al. 2000).

### Spur orientation relative to the river axis

Spurs can be attracting, deflecting, or repelling according to their inclination as shown in Figure 47. An attracting spur points downstream and attracts the flow towards its head and thus to the bank, maintaining a deep current close to the bank. A deflecting spur changes the direction of the flow without repelling it and creates a wake zone behind. A repelling spur points upstream and diverts the flow away from itself. The first spur in a bend should always be attracting to minimize the impact of the flow.

### Spur shape

Spurs are basically bar shaped, but the end protruding into the water flow can be shaped differently (Figure 48). An oval or elliptical spur, with the wider portion towards the bank, can change the hydraulic efficiency and reduce the direct impact of the flood water on the spur body. Investigations have shown that the shape of the spur can affect the bed stress distribution and the scour depth around a spur. For example, the extension of the high shear stress zone is smaller in T-shaped spurs (Safarzadeh et al. 2010), whereas the maximum scour depth is less around L-shaped spurs (Hashemi Najafi et al. 2008).

### Spur length

When choosing the length of a spur, it is important to consider the safety of the opposite bank. If a spur is too long, it may guide the river current during a flash flood to the opposite bank which will cause damage; if it is too short, it may cause erosion of the near bank. As a general rule, the length of a spur should be no more than 1/5 the river width and no less than 2.5 times the scour depth. Sometimes a spur is made long and strong with the aim of changing the river course by repelling it towards the opposite bank, in which case the opposite bank should also be protected. Both the river width and the width of the main flow channel to be deflected should be considered when designing the length of a spur (Jha et al. 2000)

The scour depth is given by

$$R = 1.35 (q^2 f)^{1/3},$$

where

$R$  = the normal scour depth below high flood level (HFL),

$q$  = discharge intensity in  $\text{m}^3/\text{s}$  per metre width, and

$f$  = Lacey's silt factor, which depends upon the grain size of the river bed material (given for different materials in Table 14).

The value of  $q$  can be obtained from  $q = \frac{Q_f}{\text{Water width}}$  in  $\text{m}^3/\text{s}/\text{m}$ ,



where the water width is the flood water width in the river and

$$Q_f = 1.2Q - 1.24Q,$$

where  $Q$  is the discharge.

### Spacing

The effect of a group of spurs depends on their length and spacing. The spacing between two spurs depends on the length of the spurs. The effect on flow is best fulfilled if one strong eddy is created between each pair of spurs (Figure 49). If the spacing is too wide, the effect of the spurs will be insufficient as parts of the bank will remain unaffected. A spacing less than the optimum is wasteful as it does not increase the effect. The length of bank protected by a spur is generally at least twice the length of the spur projecting perpendicular to the river water current; thus spurs do not need to be closer than twice their projecting length. More exact calculations can be made using the formulae for eddy stability and energy loss of river flow (HMGN 1990). In general, the spacing between two spurs should be 2–2.5 times the spur length along a concave bank and 2.5–3 times the spur length along a convex bank. In the case of a revetment with spurs, the spacing can be increased without causing harm to the bank (Jha et al. 2000).

### Number of spurs along the stream bank

The number of spurs depends on the length of stream bank to be protected and the calculated space between spurs.

### Launching apron

A launching apron should be constructed to protect the spur from scouring at the base. 'Scouring' is the name given to the removal of the bed or bank of a watercourse by the action of flowing. When river training works are carried out to protect a river bank, the obstruction of high flow discharge and the associated changed water flow pattern can lead to scouring in the form of a deep depression in the river bed close to the river training structure. Scouring can destabilize the structure and thus measures need to be taken to counteract the effect. A launching apron is a flexible stone cover placed on the bed of the river which settles into the scouring area as scouring takes place and covers the base and side of the scour hole, preventing it from developing further. An example of an apron placed to protect a bank is shown diagrammatically in the section below on guide banks.

Scouring is common around spurs and can result in their destruction. For an impermeable spur, the scour hole can reach a depth of up to 1.0–1.7 times the design flow upstream of the pool, but it is much less for permeable spurs. A launching apron should be constructed to protect impermeable spurs from scouring. For permeable spurs, it is sufficient to bury material below the spur to fill the site of the potential scour hole.

**Table 14: Lacey's silt factor for different materials**

Type of material	Size of grains (mm)	Silt factor ( $f$ )
<b>Silt</b>		
Very fine	0.052	0.4
Fine	0.081	0.5
Medium	0.158	0.7
Standard	0.323	1.0
<b>Sand</b>		
Medium	0.505	1.25
Coarse	0.725	1.50
<b>Gravel</b>		
Medium	7.28	4.75
Heavy	26.1	9.0
<b>Boulders</b>		
Small	50.1	12.0
Medium	72.5	15.0
Large	183.8	24.0

Source: Varshney et al. 1983

**Figure 49: Formation of eddy between two spurs**

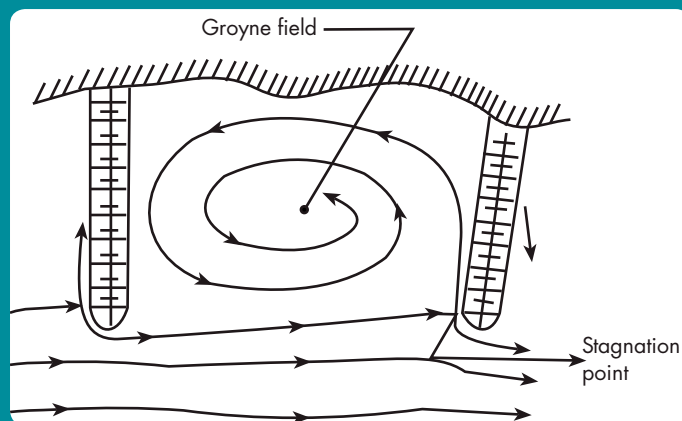

Source: HMGN 1990

## Screen dams and beam dams

Screen dams and beam dams are sediment retention structures. They are designed to trap medium to large size debris and boulders carried downstream in flood events in order to reduce the impact downstream. This type of dam is often installed in alluvial fans, along stretches with a steep slope, in wooded areas, in areas with frequent mass movements, and along narrow channel beds at the end of a valley just before the stream or river enters an alluvial fan or plains area.

The dams themselves must be constructed with strong materials such as concrete or cement to withstand the impact of heavy debris, whereas the retention portion can be built with other materials. Other supporting structures must also be constructed to protect the banks and foundation. The dams require regular maintenance; trapped debris and sediment should be removed at regular intervals and after flood events to maintain the storage capacity. These structures can have a significant environmental impact depending on their size and the materials used for construction. The most common types of screen dams and beam dams are the following.

**Screen dam with vertical bars.** This type of dam is mainly made to retain vegetative materials such as tree trunks and branches. The vertical bars are usually constructed from steel or concrete, although wood can also be used in dams for small torrents and water channels. The dam offers a high resistance to the debris.

**Beam dam with pylon bars, vertical opening, and horizontal steel bars.** These dams are constructed with concrete and steel. The main purpose is to control mass transportation of sediments that could affect settlements or other infrastructure.

## Porcupines

Porcupines are a form of permeable structure designed to reduce flow and trap sediment. They have pole-like projections in all directions, resembling a porcupine with its quills sticking into the air. They are used as flood control structures, and for river bank and bed protection. Porcupines can be used in a line forming a spur into a river, as silting aprons for larger spurs, and in a longitudinal line along an embankment. Originally such devices were made of timber or bamboo (Figure 50), but these have a limited lifespan. The use of wooden and bamboo

Figure 50: Bamboo porcupines used to form a spur



Source: Rajendra Prasad Adhikary

Figure 51: RCC porcupines along a river bank (top) and combined with sandbags to form a bar projecting into the Koshi river (bottom)



Source: Mitra Baral (top) and Shiva Kumar Sharma (bottom)

porcupines combined with vegetation to form a green wall is described in the chapter on bioengineering. This section describes porcupines made of concrete.

There are two kinds of concrete porcupine in common use: reinforced cement (RCC; Figure 51) and pre-stressed cement (PSC). Quality control of RCC struts is difficult because each strut cannot be tested separately, although a rebound hammer can be used to test the uniformity of strength throughout. PSC porcupines are better in terms of size, shape, strength, concrete mix, and steel used.

Porcupines can be constructed in two shapes, tetrahedral and prismatic (Box 17). The following are their main uses.

**Bank protection as a bar.** Porcupines can be used as a pro-siltation protection device for a natural river bank or an embankment (Figure 54). The structures are flexible, which ensures stability against extreme water forces and even earthquakes. Porcupines reduce the flow velocity, intercept and break eddies formed by floodwater, and fill up scour holes with silt.

Porcupines are most commonly used as bars across, and aligned 2–5° upstream of, the flow. Each bar consists of single, double, or triple rows based on the velocity of flow, the width of the bank line channel, and the spacing between bars (Figure 54); the higher the velocity, the higher the number of rows. Single or double rows are used when the bars are close to each other. The porcupines are generally placed so that they touch each other at the base, and with the lines staggered if there are multiple rows. The bar extends from the highest flood level line to

### Box 17: Porcupine design

#### Tetrahedral porcupines

The most common shape is tetrahedral. The porcupine is formed by assembling six concrete struts of the same length in a tetrahedral pattern (Figure 52). Individual struts are bolted together, projecting beyond the joint. The bolts are passed through holes made at the appropriate point using cheap polythene tubes during casting.

The size of a porcupine is denoted by the length of the individual struts, for example a 2 m porcupine or 3 m porcupine. The struts of 2–3 m porcupines have a cross-section of 10 x 10 cm. The individual struts are at 60 degrees to each other, thus a 2 m porcupine is about 1.7 m high and a 3 m porcupine 2.6 m high. The most common sizes in use are 2, 2.5, and 3 m. Mounted or long boom cranes are necessary to handle anything larger.

#### Prismatic porcupines

Prismatic porcupines are made with nine concrete struts joined in the form of a prism (Figure 53). Two end triangles are formed first and then joined together with three struts placed at the vertices. Struts are bolted together as for tetrahedrons.

**Figure 52: Tetrahedral porcupine (dimensions in metres, shown here for a 3 m porcupine)**

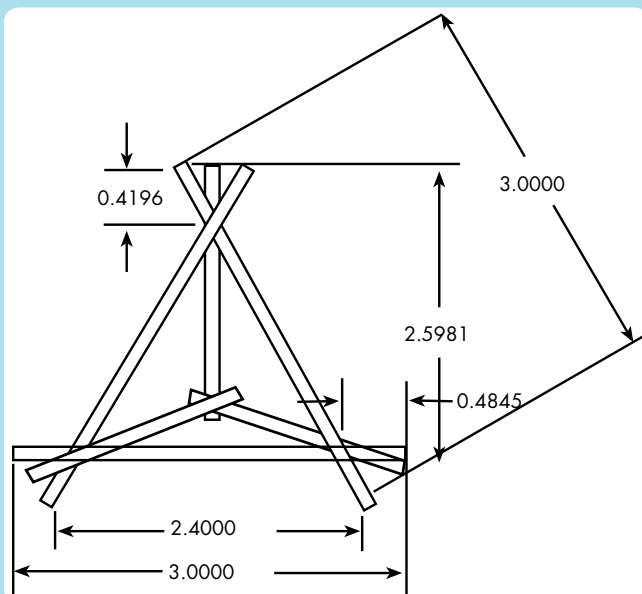

**Figure 53: Prismatic porcupine**

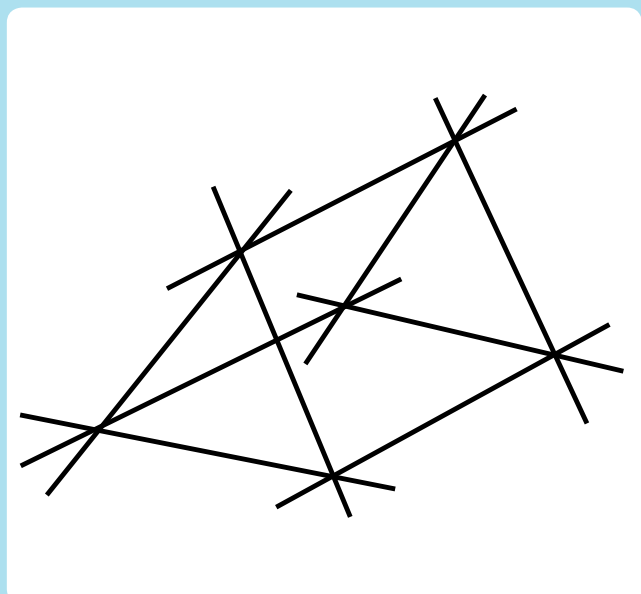
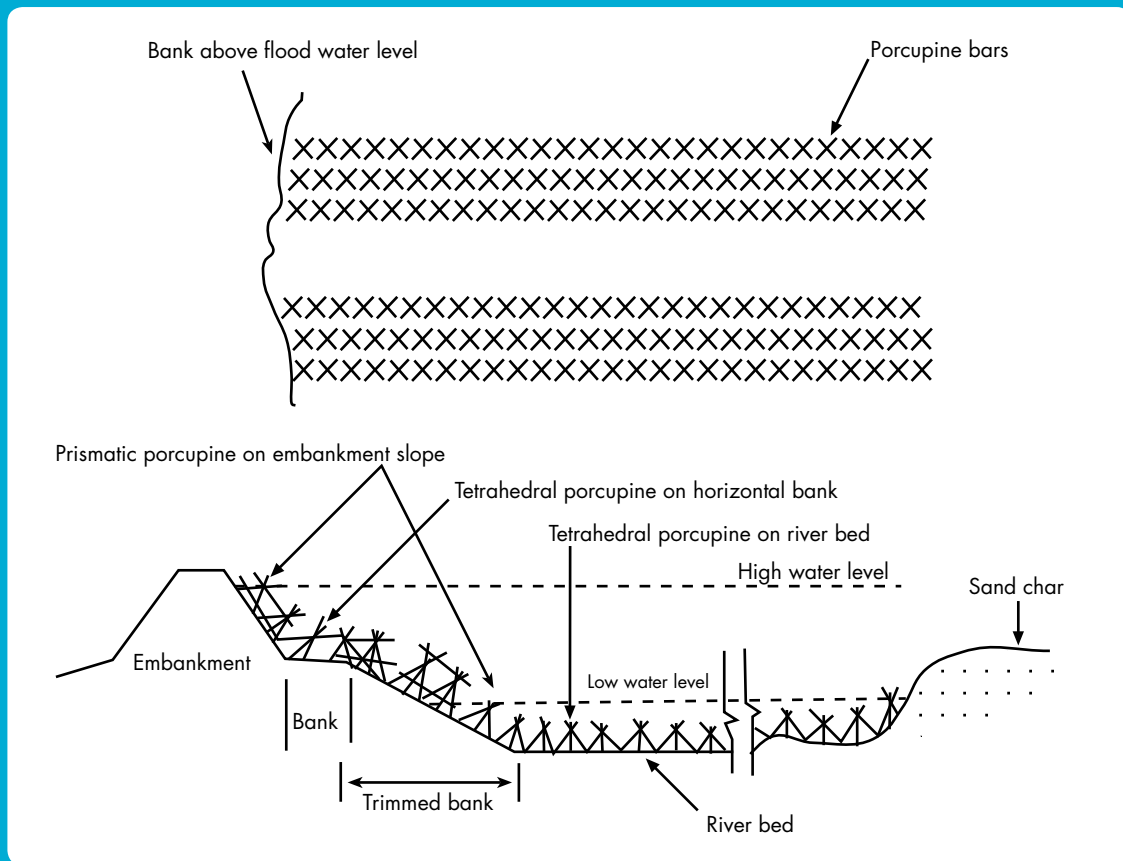

Figure 54: Plan (above) and cross-section (below) of a porcupine bar for embankment protection



the deepest scour point of the bank line channel plus a marginal distance as a factor of safety. The bars may be extended to link up with the continuous non submerged river bank or road – above the highest flood level – to avoid out flanking. To reduce costs, the extension can be for an alternate or every third bar only.

Spacing between bars is not usually the same as for spurs. The main purpose of the bar is to obtain continuous deposition of silt and not to deflect the flow away from the bank. However, wide spacing may create sand bars around each bar leaving lagoons in between, thus closer spacing is preferred. When the curvature of the eroding bank is sharp and the flow velocity is high, bars should be spaced less than 10 m apart.

**Silting apron.** Concrete porcupines are also used as silting aprons for spurs. Used in the form of a sunray, they have shown encouraging results for filling scour pits around spurs.

## Longitudinal Protection Structures

Longitudinal protection structures are installed on river banks parallel to the river course, generally with the aim of protecting adjoining areas from inundation, erosion, and river meandering. They are usually constructed on natural banks and extend for a considerable distance. The most common structures are embankments or levees in the form of guide bunds or banks, afflux bunds, and approach embankments. Very often, spurs are constructed together with longitudinal structures to protect the latter. Some common longitudinal structures are described in the following.

### Levees or earth fill embankments

Levees, or marginal embankments, are dam-like earthen structures constructed along a river in order to protect the surrounding countryside from flooding and/or to confine the course of a river to provide higher and faster water flow (Figures 55 and 56). They are usually constructed for long stretches along a river in low lying areas with an extended floodplain (Figure 57).

Figure 55: Levee along the Rapti River in Nepal



Source: Rajendra Prasad Adhikary

Figure 56: Extension of flooded river before and after levee construction

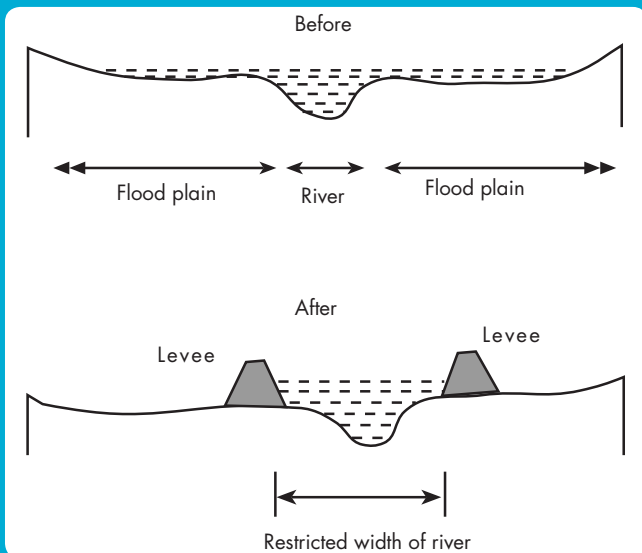
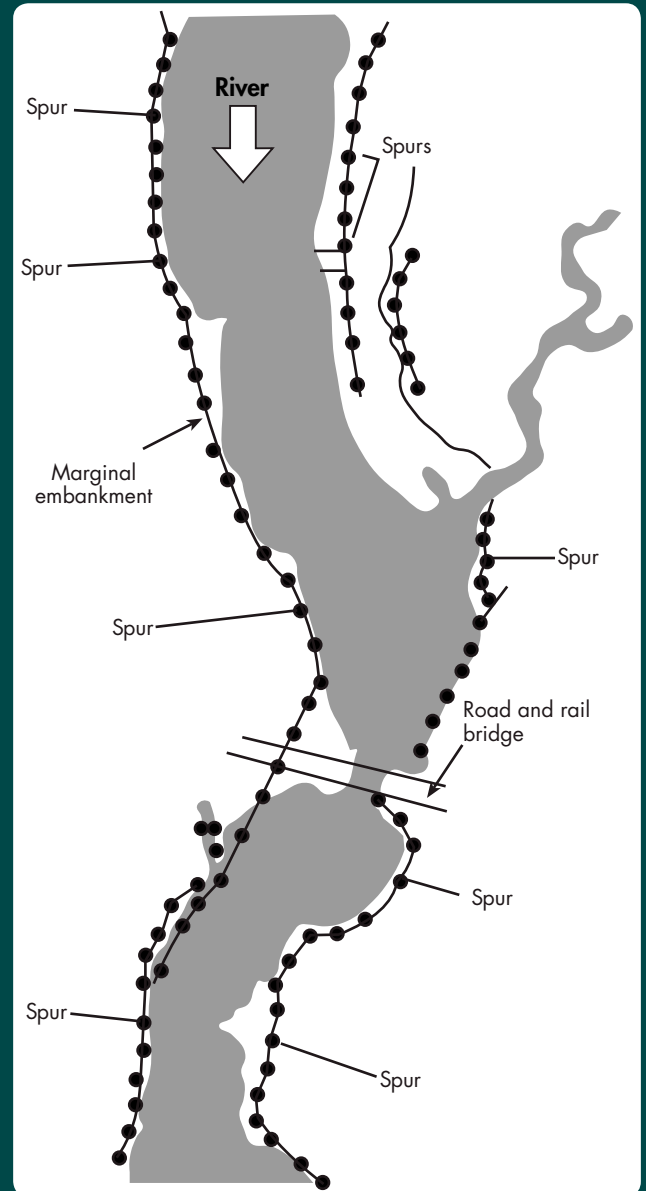

Figure 57: Levees (marginal embankments) protected by spurs along a river in the plains



Levees are usually constructed by piling earth on a cleared level surface. The type of fill material used for construction usually depends on the materials available in the local area. The levee must be designed and constructed very carefully as failure can result in catastrophic impacts.

- Both sides of the levee should be properly constructed. The slope is fixed to ensure stability, and ultimately depends on the material that the levee is made of and its height. The sides should be strengthened with riprap (see below) to prevent erosion.
- The slopes of the upstream and downstream faces of the embankment should be flat enough to provide sufficient width at the base to ensure that the maximum shear stress under flood conditions will remain well below the corresponding maximum shear strength of the soil, in order to provide a suitable factor of safety.

Specific design criteria for levees are given in Box 18.

### Guide banks and other approach embankments

Guide banks are structures built to guide a stream or river through a bridge opening or towards other hydraulic structures such as weirs, especially when river flow level is markedly higher than usual. The aim is to confine the

## Box 18: Design criteria for levees

### Freeboard

The minimum vertical distance between the maximum flood level and the top of the levee (the crown or crest) is generally taken to be 1.5 times the height of the wave ( $hw$ ), which is calculated from the following:

$$hw = 0.032\sqrt{VF} + 0.763 - 0.271 (F)^{1/4} \quad (\text{for } F < 32 \text{ km})$$

or

$$hw = 0.032\sqrt{VF} \quad (\text{for } F > 32 \text{ km}),$$

where

$V$  = velocity of wind km/hr, and

$F$  = straight length of water surface in km.

### Width

The top width of the embankment should be sufficient to keep the seepage line well within the levee. For a small levee, this top width is generally governed by the minimum roadway width requirements.

The minimum top width ( $A$ ) of an earthen levee can be calculated as follows:

$$\begin{aligned} A &= H/5 + 3 && \text{for a very low levee,} \\ A &= 0.55\sqrt{H} + 0.2H && \text{for a levee lower than 30 m, or} \\ A &= 1.65 (H + 1.5)^{1/3} && \text{for a levee higher than 30 m,} \end{aligned}$$

where  $H$  is the height of the levee.

river within a reasonable waterway and direct the flow in a manner that ensures its safe and expeditious passage (Varshney et al. 1983). They also reduce or eliminate local scour at the embankment and adjacent piers (Julien 2002). In a wide river lined by levees, a series of diversion structures may be used to guide and narrow the water course and protect the levee or highway embankment, where a highway or other bridge crosses the river. These consist of an afflux embankment or bund, an approach embankment, and the guide banks themselves (Figure 58).

Guide banks are constructed in a river in order to:

- confine the flow to a single channel,
- improve the distribution of discharge across the width of a river thus controlling the angle of attack by a flash flood,
- protect weirs, barrages, or other hydraulic structures constructed in the river such as intakes from flash floods,
- control the meander pattern of a river,
- control overtopping of natural embankments in a flash flood and protect adjacent land from flooding,
- reduce erosion of banks by the water current,
- prevent sliding of soil as a result of the draw down effect of the flood water level,
- facilitate smooth transportation of water, and
- prevent piping of water through the banks.

Two guide banks are generally required when the waterway opening is in the middle of a wide flood plain or is a braided stream where the direction of the main flow can shift from side to side. A single guide bank may be sufficient at a location where the river is confined to one side of a valley and it is possible to take advantage of a natural non-erodible bank such as a hard rock exposed surface. It is essential to check the load bearing capacity of the river bed sub-soil before choosing the location of a guide bank. The minimum width between the guide banks should be sufficient to provide the required waterway opening during the anticipated flash flood discharge.

The design of guide banks is described in Box 19.



Figure 58: Guide banks and other approach embankments

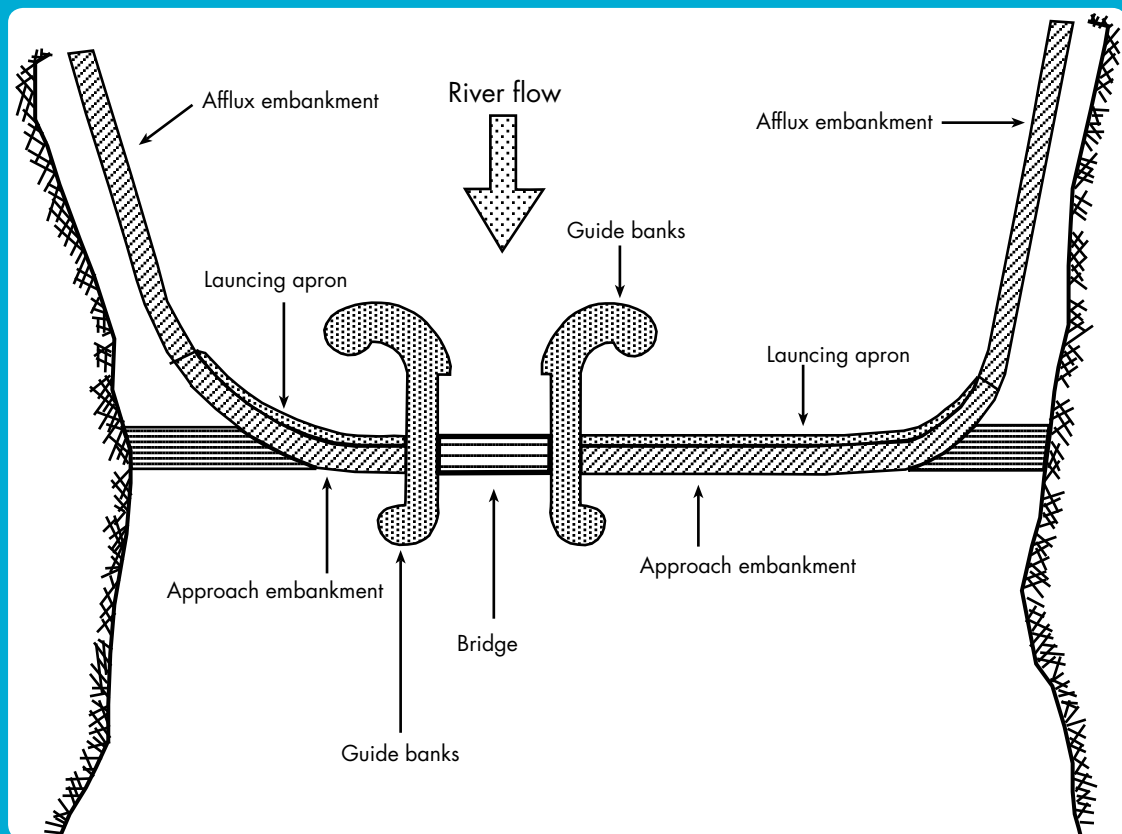

### Box 19: Design of guide banks

#### Length

For shifting alluvial rivers, the length depends on the distance necessary to secure a straight run for the river, and the distance necessary to prevent the formation of a bend in the river so as to avoid the angle of attack of the anticipated flash flood.

#### Plan shape

Ideally, the guide bank should have a converging curved shape forming a bell mouth entry to the waterway. The axis should be parallel to the principle direction of flood flow through the opening. This shape is particularly suitable where the direction of flow can vary. In most cases, the main sections of the two banks are constructed parallel to each other, but other forms are possible, for example curved or converging.

#### Embankment section

The angle of the embankment slope is calculated according to the subsoil conditions, the angle of repose of the embankment material, and the type of slope revetment provided (see below): the slope should usually have a vertical to horizontal ratio of between 2:1 and 3:1 (Singh 1980). In general, the top of the embankment is made wide enough to accommodate vehicles for construction and maintenance purposes. Guide banks should normally extend above the design high water level with a freeboard allowance of 1–1.5 m depending upon the discharge condition (Singh 1980). Lower guide banks that can be overtopped under high flood discharge condition may be preferred in some cases. Under these conditions, the top of the bank and outside slope must be protected against erosion.

#### Spacing between the guide banks

The layout of the guide banks should be such as to guide the flood smoothly throughout the guide bank length. Generally, the guide banks are constructed to form a symmetrical pair. They should confine the river within a reasonable channel that can ensure safe and rapid passage of water during a flash flood. The confined width of the river between the guide banks in an alluvial river can be calculated using Lacey's formula (Singh 1980):

$$L = 4.75 Q^{1/2},$$

where

$L$  = constrained width of the river in m, and

$Q$  = maximum discharge in  $\text{m}^3/\text{s}$  of the river during a flash flood.

This equation is for finding the wetted perimeter. In practical cases, the width is slightly more than the wetted perimeter, and the formula is modified to:

$$L = 5 Q^{1/2}.$$

The calculated waterway should be multiplied by 3–6 to give the spacing between the embankments; the exact number depends on the width, nature, river characteristics, and level of protection to be provided (Jha et al. 2000).

### Pitching

The inside slope of the embankment is subjected to erosion from the river flow, particularly during floods and flash floods. The continuous movement of water saturates the embankment material as a result of pore water pressure. Sudden increases and decreases in the water level can change the water inflow and outflow in the embankment material and damage the embankment. Hence, the inside slope should be protected by stone pitching. The usual thickness of the pitching varies from 40–60 cm. The thickness can be determined from the formula  $t = 0.60 Q^{1/3}$ , where  $t$  is the thickness in metres and  $Q$  is the maximum river water discharge in  $\text{m}^3/\text{s}$  (Varshney et al. 1983).

### Launching apron

Stone pitching protects the face of the bank. However, floods can induce scouring at the toe which would undermine the pitching and cause its collapse. To prevent this, a stone cover or launching apron is laid beyond the toe of the bank on the horizontal river bed (Figure 59). As the scour undermines the apron starting at its farther end and working back towards the slope, the apron falls to cover the face of the scour, with the stones forming a continuous carpet below the permanent slope of the guide bank. The apron must have sufficient stone to ensure complete protection of the whole of the scour face. The length of the scoured face is equal to  $5\sqrt{D}$ , where  $D$  is the anticipated scour depth below the apron.

The scouring effect is a function of the gradation of the silt available in the river bed and the discharge of the flowing water. It can be calculated using the following formula (Varshney et al. 1983):

Lacey's silt factor is:

$$f = 1.76 m r^{1/2},$$

where  $m r$  is the average diameter of the river bed material.

Depth of scour ( $R$ ) is given by

$$R = 0.47 (Q/f)^{1/3},$$

where  $Q$  = is the maximum discharge in  $\text{m}^3/\text{s}$  of the river during a flash flood.

**Figure 59: Cross-section through guide bank (numbers indicate relative values for any given size)**

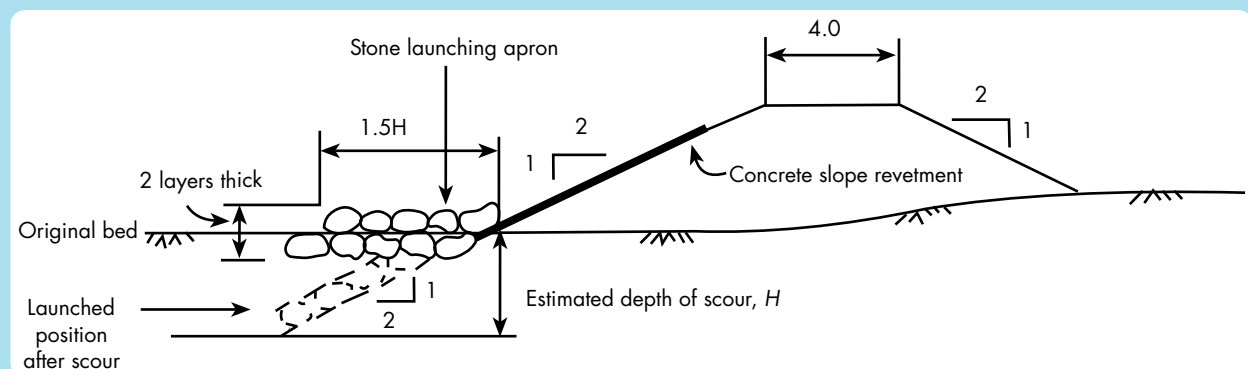

Source: HMG 1990

## Concrete embankments

Concrete embankments are made from cemented bricks, stones, or concrete. These are thin but strong embankments usually installed in urban reaches of water courses where there is not enough space to build more massive structures. They can also be combined with earth fill structures. The construction cost of concrete embankments is higher than that of earth fill embankments and such an embankment has a significant impact on the environment and often destroys the ecology of riparian areas.

## Revetments and rock riprap

Revetment refers to a continuous artificial surface on a river bank or embankment slope and part of the river bed which is designed to absorb the energy of the incoming water and protect against erosion by the river current. Revetments are usually placed along the concave side of a river bend where river velocities are high. Upstream from barrages, revetments may be used to hold approaching river banks in their existing positions. Revetments can be flexible or rigid. They can be constructed from various materials including rock, stones, stone-filled gabions, concrete slabs, timber piles, bamboo piles, old tyres, and sandbags.

If there is a potential for scour at the toe, the revetment must be extended down to the expected level of the scour and sufficient material added in the form of a thickened toe or horizontal apron such that the toe material will launch to a stable slope as the bed scour develops.

Rock riprap is one of the most common types of material used to make a revetment (see, for example, FHWA 1989; MDEP 1997). Riprap is a layer or facing of loose rough rock or other material used to armour embankments, streambeds, bridge abutments, pilings, and other structures subject to erosion by wave action and impact damage from debris carried by the waves. Riprap absorbs and deflects the energy of floodwater and debris before it reaches the defended structure, while the gaps between the rocks trap and slow the flow of water. Riprap has structural flexibility and can be constructed with locally available materials.

A riprap revetment is composed of three sections: an armour or stone layer, an underlying filter layer, and a toe protection layer. Armour is the outer layer of rough angular rock. The underlying filter layer supports the stone against settlement, allows groundwater to drain through the structure, and prevents the soil beneath from being washed through the armour by waves or groundwater seepage. The toe protection prevents downward movement of the riprap and is constructed by trenching in the riprap at the toe of the slope. Figure 60 shows the cross-section through a typical riprap revetment. Various designs can be used for toe protection depending on the exact requirements and physical location (Figure 61). The design considerations for a rock riprap revetment are described in Box 20. More detailed information can be found in FHWA (1989). This approach can be adapted for other types of revetment.

Apart from rock riprap, reformed flexible 'mattresses' can also be used to form revetments. They can be prepared from a variety of materials including willow and timber, reinforced asphalt, soil, cement, and articulated concrete. The design and construction method depend on the type. Reinforced asphalt mattresses are the most durable and abrasion resistant of the above types but highly mechanized techniques are required for their manufacture and placing. Gabion mattresses consist of flat mattresses fabricated from wire mesh and filled with stone. Mattresses are generally used to protect a bank against high velocities where stone sizes are very small.

Bags filled with sand or concrete can also be used as revetment. This type of protection is used where gravel is available but large stones are rare. This protection is rigid and almost all the failures are due to undermining of the toe at the ends of the protection.

## Porcupines used as embankment protection

Transversal arrangements of porcupines are used to reduce water velocity and encourage siltation, as described in the first part of this chapter. Longitudinal arrays of porcupines can also be used as a pro-siltation device to stabilize a river bank (Figure 63). The porcupines can be made of timber or bamboo as well as concrete. The bamboo and timber structures have a shorter life than concrete porcupines but can be more environmentally acceptable. They

Figure 60: Cross-section of typical rock riprap revetment

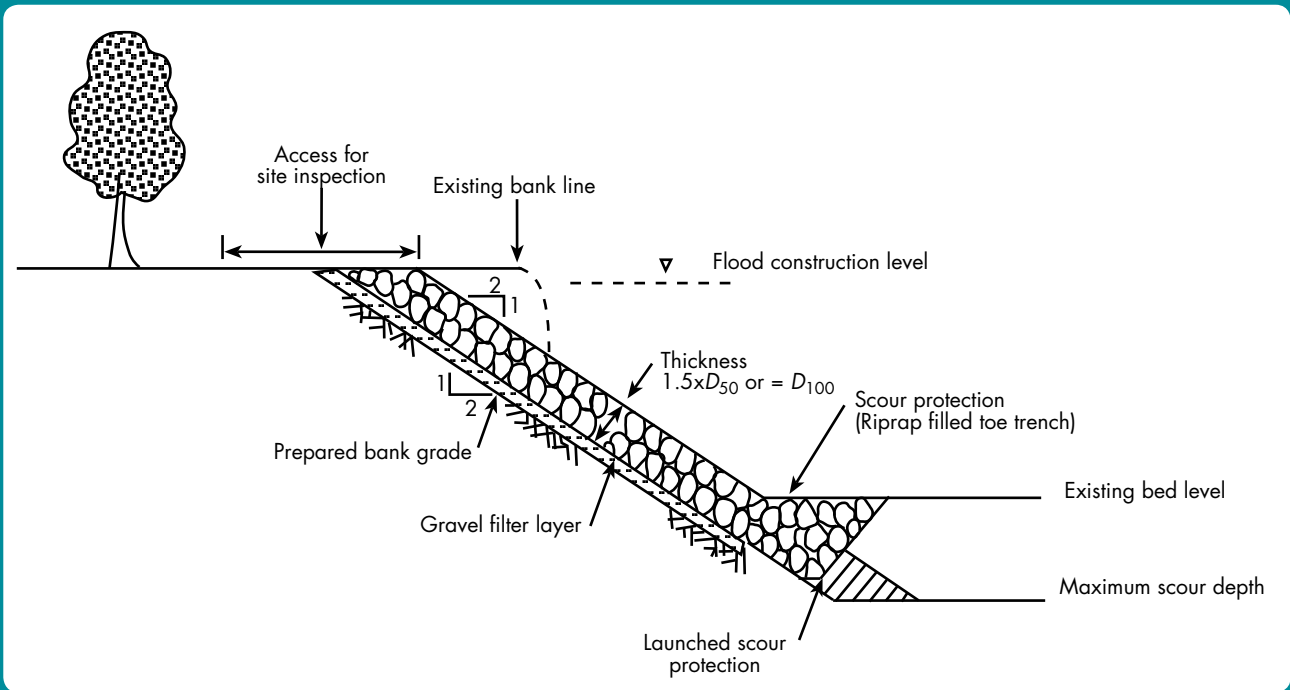
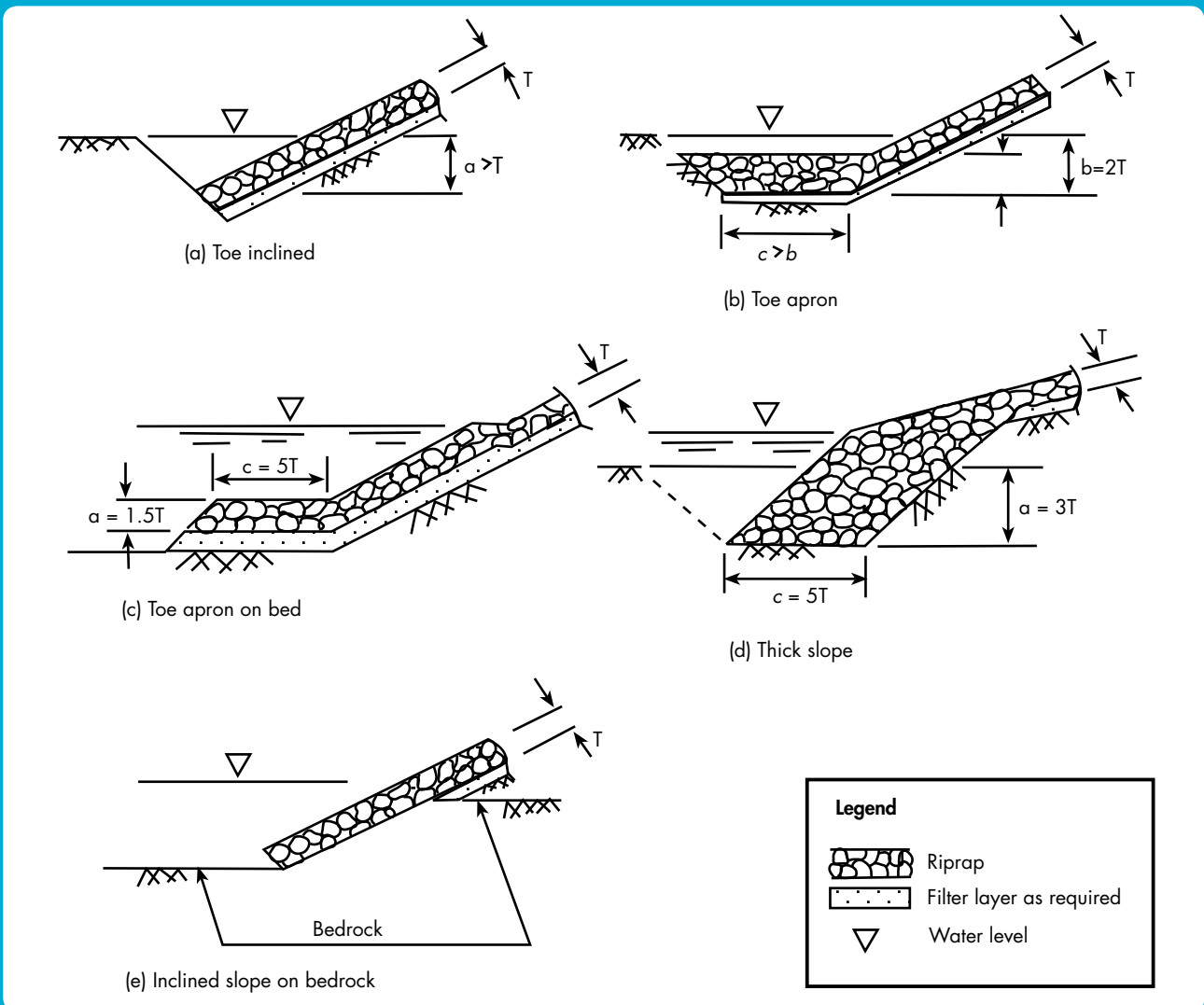

Figure 61: Different designs for the toe of a rock riprap revetment



## Box 20: Design considerations for rock riprap revetments

### Rock size

Riprap is classified as either graded or uniform. Graded riprap contains a mixture of stones which vary in size; uniform riprap contains stones which are similar in size. For most applications, graded riprap is preferred to uniform riprap. Graded riprap forms a flexible self-healing cover, while uniform riprap is more rigid and cannot withstand movement of the stones. Graded riprap is cheaper to install, requiring only that the stones be dumped so that they remain in a well-graded mass (MDEP 1997). Graded riprap is described in terms of the median diameter  $D_{50}$ : in a mixture of stones, 50% of the rock by weight will have a diameter above  $D_{50}$  and 50% below. The largest stones should not exceed 1.5 times the  $D_{50}$  specified.

The stability of the structure is provided by the well graded rock layer and the average rock diameter. Rock riprap on a stream bank is affected by the hydrodynamic drag and lift forces created by the velocity of flow past the rock. These effects are resisted by the force components resulting from the submerged weight of the rock and its geometry. The required  $D_{50}$  is determined from the expected maximum velocity of flow under flood conditions as shown in Table 15.

### Rock shape

Stones should be shaped so that the least dimension of the stone fragment is not less than one-third of the greatest dimension of the fragment. Flat rocks should not be used for riprap. Blocky and angular shaped rocks with sharp clean edges and relatively flat faces are good. If rounded stones are used, they should be placed on flatter slopes (not exceeding 2.5:1 horizontal to vertical) and the recommended median rock diameter should be increased by 25% with a comparable increase in the thickness of the revetment (USACE 1991).

### Thickness

The minimum thickness of the riprap layer should be 2.2 times the maximum stone diameter for a  $D_{50}$  of 30 cm or less, but not less than 15 cm, and twice the  $D_{50}$  for a specified  $D_{50}$  greater than 30 cm.

**Table 15: Determining median diameter ( $D_{50}$ ) of riprap from maximum flow velocity**

Maximum flow velocity (cfs)	Riprap $D_{50}$	
	cm	inches
16	91	36
13	61	24
11	46	18
10	38	15
8	25	10
6	15	6
4	7.5	3

Source: MDEP 2003

**Figure 63: Bamboo porcupines as protection along an embankment**



Source: Rajendra Prasad Adhikary

can be intertwined with living plants to form a stable structure as silt builds up and the plants root into the ground (see Chapter 4).

## Other Protection Structures

### Sandbagging

Sandbags can be used to reinforce structures (e.g., Figure 51) and to build (emergency) dikes (Hellevang 2011). They are widely used to control or reduce the devastating effects of floods particularly in plains areas. Figure 64 shows a typical use of sandbags in a toe wall along an embankment.

Sandbags can also be stacked to make a barrier against rising flood water as well as in areas where flash floods are likely (Figure 65). The sandbag wall or barrier should be constructed on a firm flat surface to prevent seepage. A trench can be dug and the bottom

### Filter blanket

A geo-textile or stone filter blanket should be placed under the riprap to prevent water from removing the underlying soil material through voids in the riprap. Generally, the filter blanket is made from a layer of well-graded gravel or sand-gravel, or synthetic filter fabric materials. The design of a gravel filter blanket is based on the ratio of the particle size in the overlying filter material to that of the base material in accordance with the following criteria (Brooks 1989, cited in PBC 2000):

$$D_{15c}/D_{85f} < 5 < D_{15c}/D_{15f} < 40,$$

where  $D_{15}$  and  $D_{85}$  refer to the 15% and 85% sieve passing sizes, and subscripts 'c' and 'f' refer to the 'coarse' and 'finer' layers, respectively.

Geo textiles can also be used as filters in place of or in combination with gravel filters. They are both cheaper and easier to install.

### Toe design and scour depth

The revetment toe must be protected from undermining by scour. A deep scour hole can form at the tip of the revetment where the flow velocity is much higher than the average channel velocity (Figure 62). The scour hole can undermine the bank leading to a collapse of the whole structure. An apron can be constructed to fill the scour hole (Figure 59).

This method is recommended for cohesionless channel beds in which deep scour is expected. In cohesive channel beds, the bank revetment should be continued down to the expected worst scour level and the excavated area refilled as shown in Figure 59 (Julien 2002).

**Figure 62: Scour hole and expected scour**

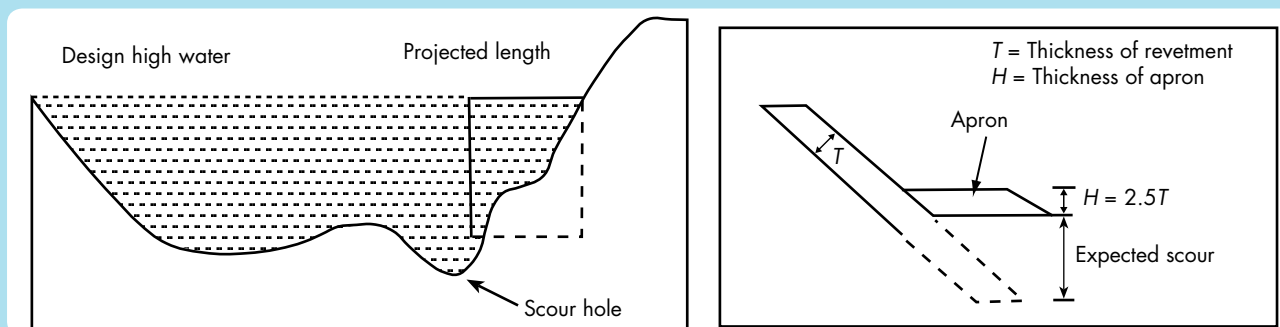

layer of bags placed in it to improve stability. Plastic sheets can be used to help seal the dike if available. It is important to construct the barrier properly to ensure that the result is effective; Hellevang (2011) provides detailed instructions. Bags can be made from various materials and in different sizes but woven polypropylene is the most common. Bags with a filled weight of no more than 30–40 pounds (14–18 kg) are easier to handle. Sand is the easiest and most available material for filling and shaping the bags. Silt and clay can also be used, but working with these materials is more difficult.

Whatever the final use, it is important to fill the bags properly. The bags should be about one-half full and tied near the top so that the sand can move easily (Figure 66). Overfilled bags and bags tied too low lead to gaps in the dike or wall, which allows water to seep through.

**Figure 64: Toe wall constructed from bamboo and sandbags**



Source: Mercy Corps



Figure 65: Sandbag dike

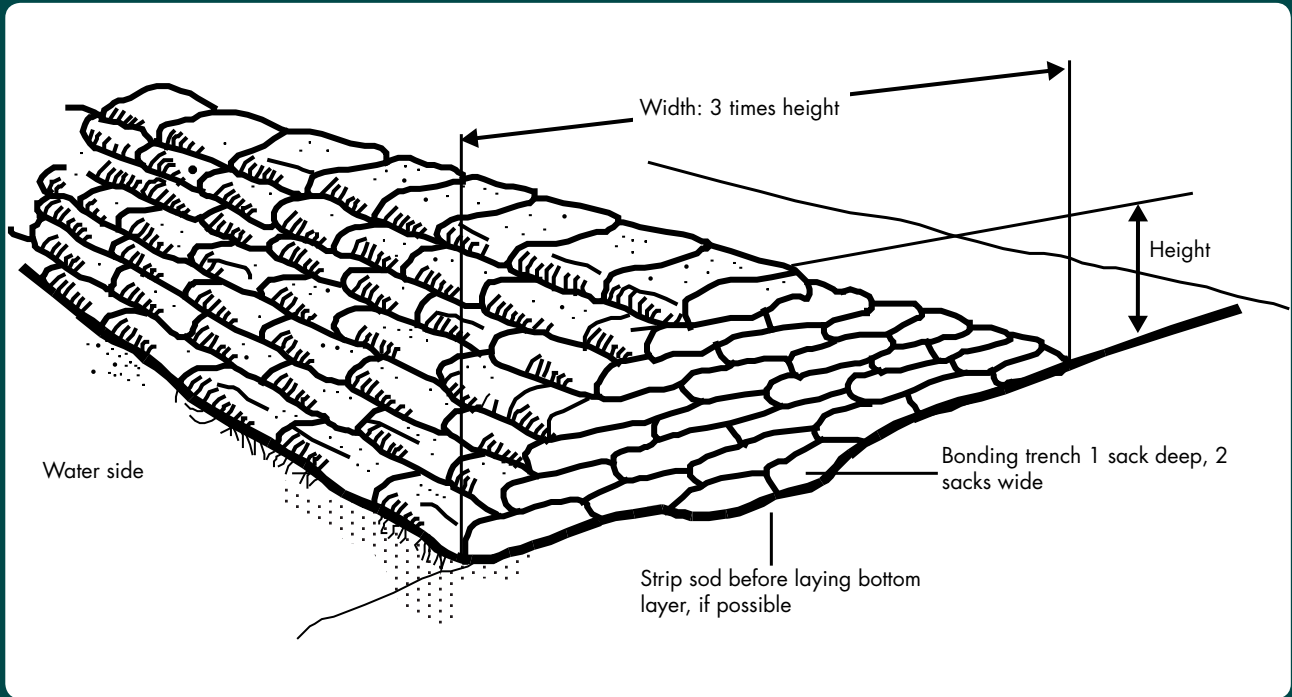
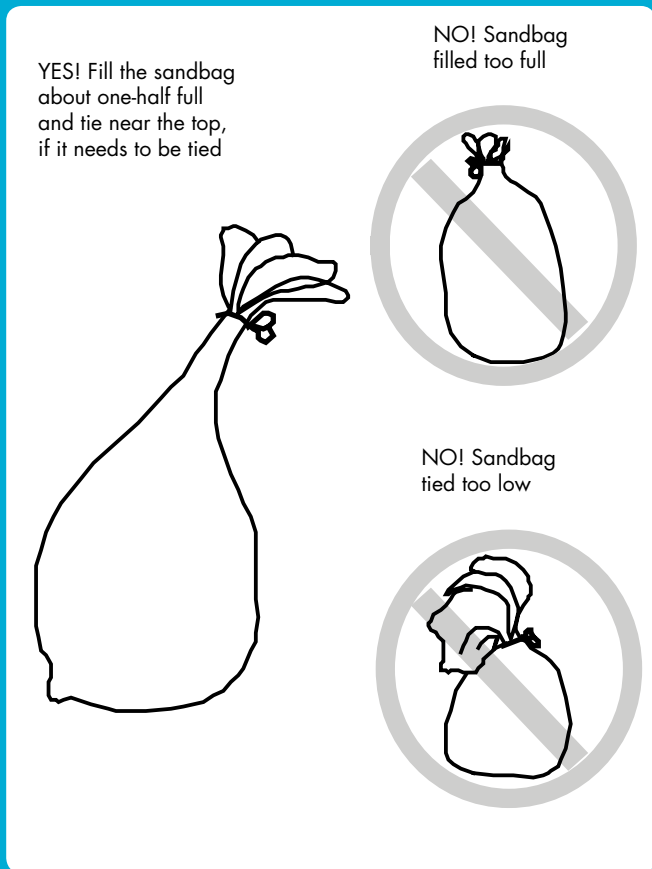

Figure 66: Correct way to fill sandbags



Source: Hellevang 2011

Figure 67: Concrete channel lining



Source: Nabin Baral

## Channel lining

Channel lining is a protective layer used to protect the banks and bed of a watercourse against erosion. Channel lining can help increase the velocity of flow to ensure easy transport of sediment and reduce deposition in the channel bed. It is recommended in catchments highly prone to erosion, particularly in urban and alluvial fan reaches. However, channel lining can have a marked environmental impact and the necessity and the type of structure should be carefully assessed.

Channel lining structures can be made from many materials including concrete (Figure 67), gabions, and wood, as well as earth, rocks, asphalt, and plastic. Concrete and cement linings have a higher environmental impact, natural materials generally a lower one. Wood channel linings are usually cheaper to install and maintain than those made of other materials.

## Bamboo piles

Bamboo can be used in the form of piles to strengthen a foundation or stabilize a flood embankment or river bed. The rows of bamboo piles should be firmly fixed with a rope or iron wire. Piling in wet soil is very easy but may otherwise require more strength. It may be necessary to excavate small holes in boulder covered parts of the river bed. Two parallel rows of piles can be prepared and the space between them filled with boulders and pebbles as a toe protection measure for flood embankments (Box 21).

### Box 21: How to use bamboo piles to develop a protection structure

#### Materials

- Bamboo piles
- Digging tools, hammer
- Boulders or pebbles

#### Installation

1. Drive piles into the ground at least 1 m deep by hammering. The piles should be about 40 cm apart and driven in to leave about 1–1.5 m exposed at the top.
2. Where there are boulders, excavate a small area and hammer the pile in. Fill in around the pile.
3. Tie the piles together with rope or iron wire.
4. Fill the space between parallel rows of piles with boulders and pebbles as a toe protection measure.

# Chapter 7: Structural Measures for Flood Management in the Context of Integrated Water Resources Management

The basis of integrated water resources management (IWRM) is that different uses of water are interdependent. Managers, whether in the government or private sectors, have to make difficult decisions on water allocation. More and more they have to apportion diminishing supplies between ever-increasing demands. Drivers such as demographic and climatic changes further increase the stress on water resources. The traditional fragmented approach is no longer viable and a more holistic approach to water management is essential (UN-Water 2008).

In the words of the Global Water Partnership: “IWRM is a process which promotes the coordinated development and management of water, land, and related resources, in order to maximize economic and social welfare in an equitable manner without compromising the sustainability of vital ecosystems and the environment. ... It is a cross-sectoral policy approach, designed to replace the traditional, fragmented sectoral approach to water resources and management that has led to poor services and unsustainable resource use. IWRM is based on the understanding that water resources are an integral component of the ecosystem, a natural resource, and a social and economic good” (GWP 2012).

The concept of IWRM offers solutions to the water crisis by linking water to other vital resources in a holistic manner and viewing the whole water cycle together with human interventions as the basis for sustainable water management. The specific approaches used need to be tailored to the individual circumstances of a country or local region.

## Integrated Flood Management

Sustainable and effective management of water resources demands a holistic approach, linking social and economic development with the protection of natural ecosystems and appropriate management links between land and water uses. Therefore water-related disasters such as floods and droughts that play an important part in determining sustainable development also need to be integrated within water resources management.

Flood management plays an important role in protecting people and their socioeconomic development in floodplains. Unfortunately, strategies that rely on structural solutions (dams and reservoirs, embankments, bypass channels) alter the natural environment of the river, resulting in losses of habitat, biological diversity, and productivity of natural systems. The need for sustainable development has highlighted the importance of addressing the negative consequences on the environment of these flood-protection measures. Environmental degradation has the potential to threaten human society in the areas of safety of life, economic wellbeing, and food and health security. Thus it is essential to consider environmental impacts in flood management activities (WMO 2006b).

There are no universal solutions that determine environmentally-friendly flood management practices. Practices should be adopted that suit the particular circumstances of a basin using the three-way approach of avoiding, reducing, and mitigating adverse environmental impacts without compromising the flood management objective. This, in essence, is integrated flood management (IFM), a process that promotes an integrated – rather than fragmented – approach. IFM integrates land and water resources development in a flood plain within the context of IWRM, and aims to maximize the net benefits from flood plains while conserving the environment and minimizing

loss to life, infrastructure, and property from flooding (APFM 2004; WMO 2006a). An integrated approach means considering all the impacts in a holistic manner by looking at linkages and interdependencies between upstream and downstream areas as well as between the river course and the flood plain. This means looking at the whole river basin with its natural boundaries in line with the flow patterns of water, rather than individual administrative areas.

IFM uses a multidisciplinary approach to flood management and involves a wide range of stakeholders, including professionals from different agencies and fields directly or indirectly related to flood management, and representatives of those most likely to be affected by flooding, as well as by anti-flooding measures. This chapter describes some integrated basin wise approaches to flood management, using some of the techniques described in the previous chapters and taking into account human and environmental needs.

## Passive Flood Control Measures

Passive flood control measures refer to the avoidance of activities that accelerate flood discharge. The main purpose is to favour natural flow retention through the interdisciplinary management of water and land resources along watercourses and preserving and improving the general environmental conditions. The main control measures are as follows (Colombo et al. 2002: 29–30):

- adaptation of cultivation in the neighbourhood of watercourses to flooding, taking into account the resistance and susceptibility to damage of different crops;
- development of forms of cultivation suitable for the local conditions in river plains;
- transfer of local cultivation to safer areas;
- public acquisition of land and structures that are more frequently subjected to floods;
- safeguarding of available lowland run-off zones covered by woods, coppice, and grassland;
- cessation of construction in flood plain areas;
- restoration of retention areas through withdrawal and displacement of dams as well as reactivation of old arms;
- preservation of natural-like trenches, and environmentally-friendly development of already trained water systems;
- promotion of land suitable for water retention or needed for building flood protection structures in land use plans;
- setting up integral land consolidation procedures both to favour passive control and foster sustainable agricultural practices; and
- building or preservation of structures to slow runoff.

## Flood Storage Reservoirs

Flood storage reservoirs or basins control floods or flash floods by detaining and storing water and then releasing it slowly at a controlled rate, thus reducing the destructive flood peak. In this method, effective flood mitigation is obtained by having an adequately-sized reservoir or group of reservoirs immediately upstream from the area to be protected. The most effective reservoirs for flood control are those located in a broad floodplain. However, these require the construction of a very long dam or embankment bounding the area where the flood water is to be stored, and a large area of valuable agricultural land would have to be flooded. Such a reservoir would catch most of the run-off water that would cause flooding to the nearby area. Sites further upstream require smaller dams and less valuable land, but they are less effective in reducing flood peaks (ADPC/UNDP 2005).

The terms 'detention' and 'retention' basins are sometimes used interchangeably, but there are some differences between them.

A detention basin is an area where excess storm water is stored or held for a short time before it drains out to a natural watercourse, or for a longer time for agricultural, consumptive, aesthetic, recreational or other uses. The water retention also helps reduce the amount of pollutants transported by runoff (Colombo et al. 2002). Detention basins are sometimes called dry ponds or holding ponds because they eventually empty out to downstream.

In some cases water remains in the basin almost indefinitely, reduced only by the net amount lost by evaporation and absorption at the surface. Such basins are called retention basins, wet ponds, or wet detention basins.

The design of water detention or retention basins includes a number of factors such as the size, stability, and impermeability of the dam or embankment, the design of the elevation and capacity of the outlet for releasing the water, and the storage volume required. Diversions are often required to channel the flow from the main river to the basin area. A variety of engineering work is required to install flood storage reservoirs.

Some of the specific considerations in the planning, design, operation, and maintenance of water retention basins have been summarized by Colombo et al. (2002):

- Hydrological elements such as the basin capacity and spillway should not be undersized. However, large retention facilities might have a high ecological impact.
- Correct hydraulic dimensioning of the operation facilities is needed similar to that for conventional dams, including correct design of the bottom outlet, the spillway, and the bypass.
- The geological setting must be taken into account, including the geotechnical properties of soils and groundwater conditions, especially for permanent lakes.
- Ecological aspects should be considered, for example the ecological continuity of the flowing water, sediment accumulation, and channel shaping downstream of the basin. The bottom outlet should be designed so as to minimize interruption of the ecological continuum of the water flow. Wherever possible, the construction of retention installations should be accompanied by ecological compensating measures. Limnological development and successional use has to be analysed if a permanent lake is to be planned.
- Bioengineering criteria should be adopted that favour restoration of the natural condition of the river course and thus the increase of biodiversity within the riparian habitat, especially in urban areas.
- The commissioning, operation, and maintenance phases should consider safety of the population in connection with urban and industrial development, land reclamation, and new traffic routes, which usually emerge in the vicinity of retention basins.
- Areas subject to flooding during events with a return period of five years or less should not be used as arable land. At best, they can be used as grassland.
- Forest management should take into account the resistance of the tree cover against floods as well as its fitness for the site. Storage of timber in the retention area should be forbidden.
- Recreational facilities must either be positioned outside the retention area or be designed to withstand floods, or appropriate safety measures should be taken.
- Use of basins for power generation, water replenishment, and/or storage of drinking and service water must be secondary to the use as a flood retention basin. In general, any secondary use of such basins should have no noticeable influence on the main purpose.
- If provision for habitats and nature conservation is made in the basins, natural succession should be the prime objective. Again, this use must be secondary to flood reduction.
- Existing retention basins should be kept in good condition and adjusted to current engineering standards based on revised hydrological and slope stability conditions.
- A qualified inspector should be appointed for major retention basins and an overseer (e.g., a water licensee) for other basins.
- The earth dam surfaces should be protected against erosion and infiltration by surface water. A dense vegetation cover such as turf can be effective.
- Dams or embankments, emergency spillways, and outlets should be checked periodically (and always after each storm) for erosion damage, piping, settling, seepage, or slumping along the toe or around the barrel. Regular maintenance should be carried out. Maintenance on the outside of the dam includes removing debris from around the inlet, mowing the embankment to keep bushes and trees from becoming established, checking the outlet pipe for cracks or other damage, and removing rodents that burrow into the dam.
- Sediments within the basin must be periodically removed and disposed of in order to maintain the volume for storage of flood water. As a rule of thumb, accumulations over one-half the design volume should not be allowed.
- The longitudinal structures enclosing the basin must be planned or adapted with maintenance roads in order to guarantee accessibility to people and machines.

In addition to the general recommendations above, there are some specific recommendations for lateral retention basins (i.e., basins constructed on flat areas close to the water course).

- Locate in central or lower portions of the catchment, where the existence of flat areas enables identification of large surfaces for the storage of significant volumes of flood water.
- Land planning of river catchments should identify bonds and prescriptions for preservation of areas that can potentially be used for lateral retention basins.
- The entrance and exit points between the river course and the basin must have protective structures installed in order to avoid erosion.
- Construction of artificial lakes and islands, and plantation of small wooded areas may favour the colonization of many different plant species.

## River Corridor Rehabilitation and Restoration

River corridor enhancement, rehabilitation, and restoration is a concept that involves different activities with a degraded river or stream in order to return it to its natural condition. In practice, restoring a river or stream to its original state is almost impossible. However, some limited enhancement works can be done to restore the river corridors.

The general environment of the riparian zone and the ecological role of the riparian vegetation must be taken into account in interventions on fluvial systems. In addition to its ecological function for aquatic habitats and terrestrial wildlife, this vegetation provides important socioeconomic benefits (e.g., flood defence, scenic and aesthetic quality, and leisure) as well as regulation of ecosystems (e.g., riverbed stability, erosion control, filtering/retention of sediments, flood defence, wastewater treatment, and pesticide control).

Ecologically oriented interventions in the riparian vegetation should consider the following criteria (Colombo et al. 2002: 32):

- keeping a structure of vegetation of different ages that allows the presence of both shrub and tree layers;
- periodic cutting and selective thinning of adult trees that present problems of stability, and elimination of invading species in favour of autochthonous species and, possibly, valued species; and
- keeping shrubby vegetation where possible, since it can bend easily during floods and does not obstruct bridge sections.

The influence of periodical flooding processes, sedimentation, and erosion can be felt in the transition areas of riparian vegetation. Structural measures to regulate the river, such as large hydraulic infrastructures that aim to improve water flow conditions, usually cause environmental changes throughout the fluvial ecosystem. These can be reflected in the destruction of habitats and vegetation, alteration of physico-chemical water characteristics, and other modifications at the level of the whole ecosystem.

The overall interventions on river corridors should focus on maintenance, rehabilitation, and restoration of well-structured corridors consisting of wide lateral strips containing varied topographical elements and populated by autochthonous grass, shrub, and tree species.

Table 16 summarizes some of the main measures used to enhance, rehabilitate, and restore river corridors. The most common efforts focus on enhancing riparian zones by planting grasses, bushes, and trees; stream bank stabilization; the removal of dams and other man-made structures; and stocking the river with fish or other living organisms.

The following principles related to the ecology of river systems can help practitioners when planning and undertaking rehabilitation projects (Cottingham et al. 2005).

- Riverine ecosystems are structured hierarchically, with important processes operating at a range of spatial scales, from large regional and catchment scales, to sub-catchment and reach scales, and ultimately down to smaller site and micro-habitat scales.
- Riverine ecosystems can also be highly dynamic and variable in space and time. As such, stream ecosystems in good condition are resilient to periodic natural ecological disturbances, such as droughts, floods, and fires, which can help drive important physical and biological processes.
- Hydrological connectivity provides strong spatial connections along river networks and between rivers and their floodplains, and plays a key role in ecological processes such as nutrient and energy cycling (spiralling), and the recovery of populations and communities following natural and human induced disturbance.



**Table 16: Measures to enhance, rehabilitate and restore river corridors**

Riverbed	Margin	Flooding area
Cleaning and removal of obstructions	Cleaning and removal of obstructions, managing damaged trees	Cleaning and removal of obstructions
Recovery and restoring of natural conditions	Recovery and restoring of natural conditions	Recovery and restoring of natural conditions
Ecological and aesthetic valorization	Ecological and aesthetic valorization	Ecological and aesthetic valorization
River-bed modification	Revegetation planting and seeding	Revegetation planting and seeding
Meandering	Stabilization, protection, and/or natural, semi-natural, and artificial revetments	Increasing hydrological communication with the river bed and margins
Narrowing/widening	Plaiteds, reed rhizomes	Level lowering
Ecological flow regime	Gabions, geo-textiles, foundation-stones, and similar, used with or without vegetal materials	Humid zones and increase of habitat diversity
Substratum modification	Flow deflectors	Flood retention basins
Silt traps	Slope modelling	Compartmentalization systems
Alternative river-beds	Buffer strips	

Source: Colombo et al. 2002: 35

- Stream rehabilitation activities are embedded in the hierarchical organization mentioned above, and should begin with an examination of large-scale factors that might constrain processes acting at smaller spatial scales. Longitudinal processes should also be considered, as the source of degradation can be some distance from the locations where ecosystem impacts are evident and rehabilitation is proposed, and loss of connectivity may constrain the biotic response to physical changes in the channel.
- The most effective form of rehabilitation is to prevent degradation of river ecosystems in the first place. The highest priority should go to protecting the remaining high quality river systems (or parts thereof), particularly those that serve as important refugia and are a potential source of colonizing organisms.
- Rehabilitation should aim to increase the resilience of river ecosystems to natural (and further human-induced) disturbances so those ecosystems become self-sustaining and capable of responding to large-scale processes such as climate change and the condition of catchments.
- Where possible, rehabilitation efforts should aim to work with natural processes. This means considering rehabilitation at broader scales than is often practised and choosing realistic rehabilitation targets. Given the nature of human impacts, it is unlikely that degraded streams can be returned to their pre-disturbance condition. In such circumstances it can be inappropriate to adopt 'return to natural' as the target for rehabilitation.
- The fragmentation of populations, coupled with sometimes low levels of connectivity (whether because of human interventions such as barriers or naturally poor dispersal abilities), means that many plant and animal species will respond to habitat restoration only very slowly. Isolation may therefore be a major constraint to biotic recovery, and in some cases this could take years or decades. Further, local extinctions may preclude full population recovery.

For rehabilitation to be successful, proper planning and interaction with stakeholders must complement the ecosystem perspective listed above. Socioeconomic considerations will play a large role in determining where and when different rehabilitation measures are applied.

# References

- ADPC/UNDP (2005) *A primer for integrated flood risk management in Asia*. Bangkok, Thailand: Asian Disaster Preparedness Center (ADPC); United Nations Development Programme (UNDP)
- Allen, HH; Leech, JR (1997) *Bioengineering for streambank erosion control: Report 1 guidelines*, Technical Report EL-97-8. Vicksburg (MS), USA: U.S. Army Corps of Engineers, Waterways Experiment Station
- APFM (2004) *Integrated flood management: Concept paper*. Geneva, Switzerland: Associated Programme on Flood Management. [www.unwater.org/downloads/concept\\_paper\\_e.pdf](http://www.unwater.org/downloads/concept_paper_e.pdf) (accessed 24 April 2012)
- APFM (2007) *Guidance of flash flood management: Recent experiences from Central and Eastern Europe*. Geneva, Switzerland: Associated Programme on Flood Management
- APROSC (1991) *Glossary of some important plant and animal names in Nepal*. Kathmandu, Nepal: Agricultural Projects Services Centre
- Bajracharya, SR; Mool, PK; Shrestha, BR (2007) *Impact of climate change on Himalayan glaciers and glacial lakes: Case studies on GLOF and associated hazards in Nepal and Bhutan*. Kathmandu, Nepal: ICIMOD
- Bentrup, G; Hoag, JC (1998) *The practical streambank bioengineering guide: User's guide for natural streambank stabilization techniques in the arid and semi-arid Great Basin and Intermountain West*. Aberdeen (ID), USA: USDA-Natural Resources Conservation Service, Plant Materials Center
- Bentrup, G (2008) *Conservation buffers: Design guidelines for buffers, corridors, and greenways*, General Technical Report SRS-109. Asheville, North Carolina: Department of Agriculture, Forest Service, Southern Research Station
- Brien, H; De Blasio, FV; Elverhoi, A; Hoeg, K (2008) 'Erosion and morphology of a debris flow caused by a glacial lake outburst flood, Western Norway.' *Landslides* 5: 271–280
- Brooks, WE; Willett, JC; Kent, JD; Vasquez, V; Rosales, T (2005) 'The Muralla Pircada – an ancient Andean debris flow retention dam, Santa Rita B archaeological site, Chao Valley, Northern Peru.' *Landslides* 2: 117–275
- Brown, SA; Clyde, ES (1989) *Design of riprap revetment*, report FHWA-IP-89-016, prepared by Sutron Corporation for U.S. Federal Highway Administration, Washington DC, USA
- Cenderelli, DA; Wohl, EE (2001) 'Peak discharge estimates of glacial-lake outburst floods and "normal" climatic floods in the Mount Everest region, Nepal.' *Geomorphology* 40: 57–90
- Colombo, AG; Hervas, J; Arellano, ALV (2002) *Guidelines on flash floods prevention and mitigation*. Ispra, Italy: NEDIES [http://eusoils.jrc.ec.europa.eu/Esdb\\_Archive/eusoils\\_docs/other/EUR20386EN.pdf](http://eusoils.jrc.ec.europa.eu/Esdb_Archive/eusoils_docs/other/EUR20386EN.pdf) (accessed 19 June 2012)
- Cottingham, P; Bond, N; Lake, PS; Arthington, A; Outhet, D (2005) *Recent lessons of river rehabilitation in eastern Australia*, Technical report. Canberra, Australia: CRC for Freshwater Ecology
- Cruden, DM (1991) 'A simple definition of a landslide.' *Bulletin of the International Association of Engineering Geology* 43: 27–29
- Cruden, DM; Varnes, DJ (1996) 'Landslide types and processes.' In Turner, AK; Schuster, RL (eds), *Landslides: Investigation and Mitigation*, Transportation Research Board Special Report 247, pp 37–75. Washington DC, USA: National Academies Press
- Dekens, J (2007) *Herders of Chitral: The lost messengers? Local knowledge on disaster preparedness in Chitral District, Pakistan*. Kathmandu, Nepal: ICIMOD
- Dhital, MR; Khanal, N; Thapa, KB (1993) *The role of extreme weather events, mass movements, and land use changes in increasing natural hazards*. Kathmandu, Nepal: ICIMOD
- Dixit, A (2003) 'Floods and vulnerability: Need to rethink flood management.' *Natural Hazards* 28: 155–179
- DSCWM (2004) *Soil conservation and watershed management measures and low cost techniques*. Kathmandu, Nepal: HMG Nepal, Soil Conservation and Watershed Management Component (NARMSAP), Department of Soil Conservation and Watershed Management; Danida
- DSCWM (2005) *Training handout on bioengineering and survey: Design and estimation of soil conservation activities*. Kathmandu, Nepal: HMG Nepal, Soil Conservation and Watershed Management Component (NARMSAP), Department of Soil Conservation and Watershed Management; Danida
- DWIDP/JICA (2004a) 'Bioengineering guideline for hill slope stabilization.' In *Collection of guidelines regarding the project period of DPTC/DMSP*. Kathmandu, Nepal: Department of Water Induced Disaster Prevention (DWIDP), Disaster Mitigation Support Programme Project (DMSP); JICA

- DWIDP/JICA (2004b) 'The basis principles of landslides, Training textbook.' In *Collection of guidelines regarding the project period of DPTC/DMSP*. Kathmandu, Nepal: Department of Water Induced Disaster Prevention (DWIDP), Disaster Mitigation Support Programme Project (DMSP); JICA
- EC (1997) Premo98: Prevention in the mountains for protection of the valleys: Principles and guidelines for the environmental protection of drainage basins prone to flash floods. Experimental intervention in a pilot drainage basin (Section 3.3.3: River training works). Brussels, Belgium: European Commission. [http://ec.europa.eu/echo/civil\\_protection/civil/pdfdocs/pr98f02.pdf](http://ec.europa.eu/echo/civil_protection/civil/pdfdocs/pr98f02.pdf) (check dams and sills) [http://ec.europa.eu/echo/civil\\_protection/civil/prote/cpactiv/cpact05g.htm](http://ec.europa.eu/echo/civil_protection/civil/prote/cpactiv/cpact05g.htm) (links to full report) (accessed 21 June 2012)
- Eriksson, M; Xu, J; Shrestha, AB; Vaidya, R; Nepal, S; Sandstrom, K (2009) *The changing Himalayas : Impact of climate change on water resources and livelihoods in the greater Himalayas*. Kathmandu, Nepal: ICIMOD
- FHWA (1989) *Design of riprap revetment*, Hydraulic Engineering Circular No. 11 (HEC-11 Sl) Publication No. FHWA-IP-89-016. McClean (VA), USA: Federal Highway Administration, Research, Development, and Technology. [www.fhwa.dot.gov/engineering/hydraulics/pubs/hec/hec11sl.pdf](http://www.fhwa.dot.gov/engineering/hydraulics/pubs/hec/hec11sl.pdf) (converted document in metric units); <http://isddc.dot.gov/OLPFiles/FHWA/009881.pdf> (original document with imperial and metric units) (accessed 27 June 2012)
- FRM (2009) *Flood Risk Management Act 2009: Scotland* (asp 6). London and Edinburgh, UK: UK Government. [www.legislation.gov.uk/asp/2009/6/pdfs/asp\\_20090006\\_en.pdf](http://www.legislation.gov.uk/asp/2009/6/pdfs/asp_20090006_en.pdf) (accessed 12 January 2012)
- Geyik, MP (1986) *Watershed management field manual – gully control*, FAO Conservation Guide 13/2. Rome, Italy: Food and Agriculture Organization
- Grabs, WE; Hanisch, J (1993) 'Objectives and prevention methods for glacier lake outburst floods (GLOFs).' In *Snow and glacier hydrology: Proceedings of the Kathmandu symposium*, November 1992, pp 341–352. Wallingford, UK: IAHS Press
- Gray, DH; Sotir, RB (1996) *Biotechnical and soil bioengineering slope stabilization: A practical guide for erosion control*. New York, USA: Wiley
- GTZ and SDC (1999) *Green roads in Nepal: Best practices report (2<sup>nd</sup> edn)*. Kathmandu, Nepal: German Technical Cooperation and Swiss Agency for Development and Cooperation. [www.scribd.com/doc/23231563/Green-Road-in-Nepal-Best-Practices](http://www.scribd.com/doc/23231563/Green-Road-in-Nepal-Best-Practices) (accessed 23 April 2012)
- Guedel, N (2008) 'Gully plugging using check dams, WOCAT database QT NEP14.' In *Natural resource management approaches and technologies in Nepal*. Kathmandu, Nepal: ICIMOD
- GWP (2012) *What is IWRM?* Stockholm, Sweden: Global Water Partnership. <http://www.gwp.org/The-Challenge/What-is-IWRM/> (accessed 26 June 2012)
- Hashemi Najafi, SFA; Ayoubzadeh, SA; Dehghani, AA (2008) 'Experimental investigation of scour depth around L-head groynes under clear water condition.' *Journal of Agricultural Sciences and Natural Resources* 15(1): 192–203
- Hellevang, K (2011) *Sandbagging for flood protection*. Fargo (ND), USA: North Dakota State University Extension Service. [www.ag.ndsu.edu/pubs/ageng/safety/ae626.pdf](http://www.ag.ndsu.edu/pubs/ageng/safety/ae626.pdf) (accessed 19 June 2012)
- HMGN (1990) *Design manuals for irrigation projects in Nepal, M.7 Headworks, river training works and sedimentation manual*. Kathmandu, Nepal: His Majesty's Government of Nepal, Ministry of Water Resources, Department of Irrigation, Planning and Design Strengthening Project
- HMGN (1999) *Bio-engineering information, rate analysis norms (interim), standard specifications (interim), lists of species, and supporting information*. Kathmandu, Nepal: His Majesty's Government of Nepal, Ministry of Works and Transportation, Department of Road, Geo-environmental unit. [www.dor.gov.np/documents/5.%20Bio-Engineering%20Information%20\(Rate%20Analysis%20Norms\).pdf](http://www.dor.gov.np/documents/5.%20Bio-Engineering%20Information%20(Rate%20Analysis%20Norms).pdf) (accessed 11 July 2012)
- Howell, J (1999) *Roadside bio-engineering: Site handbook*. Kathmandu, Nepal: His Majesty's Government of Nepal, Department of Roads
- ICIMOD (1991a) *Mountain risk engineering handbook*, Volume 1. Kathmandu, Nepal: ICIMOD. [www.icimod.org/publications/index.php/search/publication/76](http://www.icimod.org/publications/index.php/search/publication/76) (accessed 15 July 2012)
- ICIMOD (1991b) *Mountain risk engineering handbook*, Volume 2. Kathmandu, Nepal: ICIMOD. [www.icimod.org/publications/index.php/search/publication/77](http://www.icimod.org/publications/index.php/search/publication/77) (accessed 15 July 2012)
- ICIMOD (2007) *Good practices in watershed management*. Kathmandu, Nepal: ICIMOD
- ICIMOD (2008) *Natural resource management approaches and technologies in Nepal*, NEPCAT Fact Sheets. Kathmandu, Nepal: ICIMOD
- ICIMOD (2011) *Glacial Lakes and glacial lake outburst floods in Nepal*. Kathmandu, Nepal: ICIMOD
- Ikeda, A (2004) 'Design of sabo dam.' In *Collection of guidelines regarding to the project period of DPTC/DMSP*. Kathmandu, Nepal: Department of Water Induced Disaster Prevention (DWIDP); Disaster Mitigation Support Programme Project (DMSP); JICA

- Ives, JD; Shrestha, RB; Mool, PK (2010) *Formation of glacial lakes in the Hindu Kush-Himalayas and GLOF risk assessment*. Kathmandu, Nepal: ICIMOD
- Jha, H; Jha, S; Karmacharya, B (2000) *Flood control measures, best practice report. An approach for community based flood control measures in the Terai rivers*. Kathmandu, Nepal: German Technical Cooperation (GTZ)
- JICA (2006) 'Technical guidance for landslide analysis and landslide mitigation measures in Nepal.' In *Collection of guidelines regarding the project period of DPTC/DMSP*. Kathmandu, Nepal: Department of Water Induced Disaster Prevention (DWIDP), Disaster Mitigation Support Programme Project (DMSP); JICA
- Julien, PY (2002) *River mechanics*. Cambridge, UK: Cambridge University Press
- Kattelmann, R; Watanabe, T (1996) 'Draining Himalayan glacial lakes before they burst.' In *Destructive water: Water-caused natural disasters, their abatement and control*, Proceedings of the Conference held at Anaheim, California, June 1996. Wallingford, UK: IAHS Press
- Klijn, F; Bruijn, K; Olfert, A; Penning-Rowsell, E; Simm, J; Wallis, M (2009) *Flood risk assessment and flood risk management: An introduction and guidance based on experiences and findings of FLOOD site (an EU-funded Integrated Project)*. Delft, Netherlands: FLOODsite
- Lammeranner, W; Rauch, HP; Laaha, G (2005) 'Implementation and monitoring of soil bioengineering measures at a landslide in the middle mountains of Nepal.' *Plant and Soil* 278: 159–170
- Li, G; Clarke, D (2007) 'Vegetation patterns and the prediction of debris flow.' In Chen, C; Major, JJ (eds), *Debris-flow hazards mitigation: Mechanics, prediction, and assessment*, pp 35–44. Rotterdam, Netherlands: Mill Press
- Maccaferri Australia (n.d.) Hydraulic structures: Groynes. Internet document, available at: [www.maccaferri.com.au/wawcs0137320/idDetails=213/Solutions-Groynes](http://www.maccaferri.com.au/wawcs0137320/idDetails=213/Solutions-Groynes) (accessed 20 April 2011)
- Mal, BC (1999) *Introduction to soil and water conservation engineering (surveying, irrigation, drainage and soil conservation)*. New Delhi, India: Kalyani Publishers
- McCullah, J; Gray, D (2005) *Environmentally sensitive channel – and bank – protection measures*, NCHRP Report 544. Washington DC, USA: National Cooperative Highway Research Program, Transportation Research Board
- MDEP (1997) *Erosion and sediment control guidelines for urban and suburban areas (Riprap)*, pp 125–129. Boston (MA), USA: Massachusetts Department of Environmental Protection. <http://www.mass.gov/dep/water/esssec2.pdf>
- MDEP (2003) *Maine erosion and sediment control best management practices (BMPs) – E6 Riprap waterways*. Augusta (ME), USA: Maine Department of Environmental Protection, Bureau of Land and Water Quality. <http://www.maine.gov/dep/land/erosion/escbmps/escsectione6.pdf>
- Mehta, M (2007) 'Gender and natural disasters: New challenges for mountain development.' *Disaster Preparedness* 53: 17–19
- Mool, PK (1995) 'Glacier lake outburst floods in Nepal.' *Journal of Nepal Geological Society* 11: 273–280
- Mool, P; Bajracharya, SR; Joshi, SP (2001) *Inventory of glaciers, glacier lakes and glacial lake outburst floods, monitoring and early warning system in the Hindu Kush-Himalayan region*. Kathmandu, Nepal: ICIMOD
- NABARD (2012) *Technical digest, Issue 14*. Mumbai, India: National Bank for Agriculture and Rural Development, Technical Services Department [www.nabard.org/fileupload/DataBank/TechnicalDigest/Tech-Digest%20Issue%2014%20Jan%202012.pdf](http://www.nabard.org/fileupload/DataBank/TechnicalDigest/Tech-Digest%20Issue%2014%20Jan%202012.pdf) (accessed 19 June 2012)
- Nettleton, IM; Martin, S; Hencher, S; Moore, R (2005) 'Debris flow types and mechanisms.' In Winter, MG; Macgregor, F; Shackman, L (eds), *Scottish Road Network Landslides Study*, pp 45–67. Edinburgh, UK: Scottish Government, the Scottish Executive
- ODNR (n.d.a) *Live cribwalls*, Ohio Stream Management Guide No. 17. Columbus, Ohio, USA: Ohio Department of Natural Resources. [www.dnr.state.oh.us/Portals/7/pubs/fs\\_st/stfs17.pdf](http://www.dnr.state.oh.us/Portals/7/pubs/fs_st/stfs17.pdf) (accessed 25 June 2012)
- ODNR (n.d.b) *Live fascines*, Ohio Stream Management Guide No 14. Columbus, Ohio, USA: Ohio Department of Natural Resources. [www.dnr.state.oh.us/portals/7/pubs/fs\\_st/stfs14.pdf](http://www.dnr.state.oh.us/portals/7/pubs/fs_st/stfs14.pdf) (accessed 25 June 2012)
- PBC (2000) *Riprap design and construction guide*. Victoria (BC), Canada: Province of British Columbia, Ministry of Environment, Lands and Parks [www.env.gov.bc.ca/wsd/public\\_safety/flood/pdfs\\_word/riprap\\_guide.pdf](http://www.env.gov.bc.ca/wsd/public_safety/flood/pdfs_word/riprap_guide.pdf) (accessed 25 June 2012)
- Rana, B; Shrestha, AB; Reynolds, JM; Aryal, R; Pokhrel, AP; Budhathoki, KP (2000) 'Hazard assessment of the Tsho Rolpa glacier lake and ongoing remediation measures.' *Journal of Nepal Geological Society* 22: 563–570
- Richardson SD; Reynolds JM (2000) 'An overview of glacial hazards in the Himalayas.' *Quaternary International* 65/66: 31–47
- Safarzadeh, A; Salehi Neyshabouri, SAA; Ghodsian, M; Zarrati, AR (2010) 'Experimental study of head shape effects on shear stress distribution around a single groyne.' In Dittrich, A; Koll, Ka; Aberle, J; Geisenhainer, P (eds), *River flow 2010*, Proceedings of 5th International Conference on Fluvial Hydraulics, September 8–10, 2010, Braunschweig, Germany, pp 651–657. Karlsruhe, Germany: Bundesanstalt für Wasserbau. [http://vzb.baw.de/digitale\\_bib/riverflow2010/PDF/A5/A5\\_02.pdf](http://vzb.baw.de/digitale_bib/riverflow2010/PDF/A5/A5_02.pdf) (accessed 26 June 2012)

- Schiechl, HM; Stern, R (1992) *Handbuch für naturnahen Erdbau. Eine Anleitung für ingenieurbio-logische Bauweisen*. Vienna, Austria: Österreichischer Agrarverlag (German)
- SDC (2008) *Asia brief: Nepal – Roads to prosperity partnership results*. Berne, Switzerland: SDC East Asia Division
- Shang, Y; Yang, Z; Li, L; Liu, D; Liao, Q; Wang, Y (2003) 'A super-large landslide in Tibet in 2000: Background, occurrence, disaster, and origin.' *Geomorphology* 54: 225–243
- Sharda, VN; Juyal, GP; Prakash, C; Joshi, BP (2007) *Soil conservation and watershed management: Training manual, Volume II*. Dehradun, India: Soil and Water Conservation Engineering, Central Soil & Water Conservation Research and Training Institute
- Shrestha, AB (2008) *Resource manual on flash flood risk management, Module 2: Non-Structural Measures*. Kathmandu, Nepal: ICIMOD
- Shrestha, AB; Chapagain, PS; Thapa, R (2011) *Flash flood risk management: A training of trainers manual*. Kathmandu, Nepal: ICIMOD
- Singh, AK (2010) 'Bioengineering techniques of slope stabilization and landslide mitigation.' *Disaster Prevention and Management* 19: 384–397. <http://www.emeraldinsight.com/journals.htm?articleid=1865068&show=abstract> (accessed 26 June 2012)
- Singh, G (1980) *Irrigation engineering*. Delhi, India: Standard Book House
- Singh, U; Wadhvani, AM; Johri, BM (1983) *Dictionary of economic plants in India*. New Delhi, India: Indian Council of Agricultural Research
- Sinha, PC (1998) *Geological and mass movement disasters*, Encyclopaedia of Disaster Management Series. New Delhi, India: Anmol Publication
- Suresh, R (1997) *Soil and water conservation*. New Delhi, India: Engineering Standard Publishers Distributors
- Tabacchi, E; Lambs, L; Guillo, H; Planty-Tabacchi, AM; Muller, E; Decamps, H (2000) 'Impacts of riparian vegetation on hydrological processes.' *Hydrological Processes* 14: 2959–2976
- Takahashi, T (2007) *Debris flow: Mechanics, prediction and countermeasures*. London, UK: Taylor & Francis
- Tang, Y (1999) *Manual on contour hedgerow intercropping technology*. Kathmandu, Nepal: ICIMOD
- Tang, Y; Murray AB (2004) *Impact of contour hedgerows: A case study*. Kathmandu, Nepal: ICIMOD
- Tognacca, C; Bezzola, GR; Minor, HE (2000) 'Threshold criterion for debris-flow initiation due to channel-bed failure.' In Wiczorek, GF; Naeser, ND (eds), *Debris-flow hazards mitigation: Mechanics, prediction and assessment*, pp 89-97, Rotterdam, Netherlands: Balkema
- Uhlir, CF (1998) 'Landslide-dammed lakes: A case study of the Lamabagar and Chaurikharka landslide deposits, Dolakha and Solukhumbu districts, eastern Nepal.' *Journal of Nepal Geological Society* 18: 329–334
- UN-Water (2008) *Status report on IWRM and water efficiency plans for CSD16*. New York (NY), USA: UN-Water. [www.unwater.org/downloads/UNW\\_Status\\_Report\\_IWRM.pdf](http://www.unwater.org/downloads/UNW_Status_Report_IWRM.pdf) (accessed 24 April 2012)
- Upadhyaya, M (2009) 'Traditional technologies for water harvesting.' *ICIMOD, Sustainable Mountain Development* (56): 24–26
- USACE (1991) *Hydrographic surveying*, Engineer Manual EM 1110-2-1003. Washington DC, USA: U.S. Army Corps of Engineers
- Vaidya, RA (2009) 'The role of water storage in adaptation to climate change in the HKH region.' *ICIMOD, Sustainable Mountain Development* (56): 10–13
- Varnes, DJ, (1978) 'Slope movement types and processes.' In Schuster, RL; Krizek, RJ (eds), *Landslides: Analysis and control*, Transportation Research Board Special Report 176, pp 11–33. Washington DC, USA: United States National Research Council
- Varshney, RS; Gupta, SC; Gupta, RL (1983) *Theory and design of irrigation structures, Vol. I, Channels and tubewells* (5th edn). Roorkee, India: Nem Chand & Bros
- Vazirani, VN; Ratwani, MM (1980) *Analysis of structure: Analysis, design & detail of structures*, Vol. II, (8th edn). Delhi, India: Khanna Publishers
- Vuichard, D; Zimmermann, M (1987) 'The 1985 catastrophic drainage of a moraine-dammed lake, Khumbu Himal, Nepal: Cause and consequences.' *Mountain Research and Development* 7: 91–110
- WHO/UNEP (1991) *Surface water drainage for low income communities*. Geneva, Switzerland: World Health Organization and United Nations Environment Programme
- WMO (2006a) *Environmental aspects of integrated flood management*, APFM Technical Document No 3, Flood Management Policy Series. Geneva, Switzerland: World Meteorological Organization
- WMO (2006b) *Integrated flood management: Some environmental issues*, WMO Bulletin Geneva, Switzerland: World Meteorological Organization

- Wu, J; Li, T (2001) 'Behaviour and characteristics of debris flows.' In Li Tianchi; Chalise SR; Upreti BN (eds), *Landslide hazard mitigation in the Hindu Kush-Himalayas*, pp 203–214. Kathmandu, Nepal: ICIMOD
- Xu, J; Shrestha, A; Vaidya, R; Eriksson, M; Hewitt, K (2007) *The melting Himalayas: Regional challenges and local impacts of climate change on mountain ecosystems and livelihoods*. Kathmandu, Nepal: ICIMOD
- Zhou, L; Wan, X (2005) *Flash floods events and mitigation management in China*. Capacity building for flash floods management and sustainable development in the Himalayas: Status report of flash floods events and mitigation management in China, a report submitted to ICIMOD, Kathmandu, Nepal
- Zhu, P; Li T (2000) 'Flash flooding caused by landslide dam failure.' *ICIMOD Newsletter* 38: 4–5
- Zhu, PY; Wang, CH; Wang, YC (2003) 'Formation of an exceptionally serious outburst flood from a landslide dam in Tibet.' *Newsletter of Japanese Landslide Society* 14/15: 23–25
- Zhuang, J (2010) *The 12 May Wenchuan earthquake-induced landslide lakes: Distribution and preliminary risk evaluation*. Paper presented at the workshop on State of the Art in Flash Flood Risk Management in the Himalayas, ICIMOD, 15–16 February 2010, Kathmandu, Nepal









© ICIMOD 2012  
**International Centre for Integrated Mountain Development**  
GPO Box 3226, Kathmandu, Nepal  
**Tel** +977-1-5003222 **Fax** +977-1-5003299  
**Email** [info@icimod.org](mailto:info@icimod.org) **Web** [www.icimod.org](http://www.icimod.org)  
**ISBN** 978 92 9115 265 0