

INTRODUCTION TO LOW COST SANITATION

LATRINE CONSTRUCTION

A CAWST CONSTRUCTION MANUAL
FEBRUARY 2011 Edition

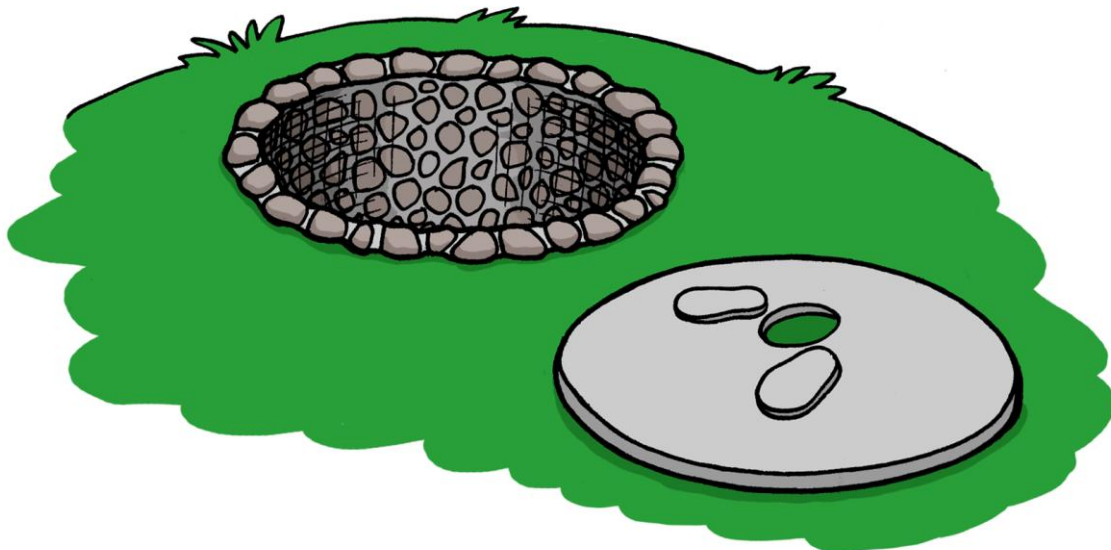



12, 2916 – 5th Avenue
Calgary, Alberta, T2A 6K4, Canada
Phone: + 1 (403) 243-3285, Fax: + 1 (403) 243-6199
E-mail: cawst@cawst.org, Website: www.cawst.org

CAWST is a Canadian non-profit organization focused on the principle that clean water changes lives. Safe water and basic sanitation are fundamentals necessary to empower the world's poorest people and break the cycle of poverty. CAWST believes that the place to start is to teach people the skills they need to have safe water in their homes.

CAWST transfers knowledge and skills to organizations and individuals in developing countries through education, training and consulting services. This ever expanding network can motivate individual households to take action to meet their own water and sanitation needs.

One of CAWST's core strategies is to make knowledge about water common knowledge. This is achieved, in part, by developing and freely distributing education materials with the intent of increasing its availability to those who need it most. You should feel free to copy and distribute this document in any form, printed or electronic. If you wish to use any parts of this document in the creation of your own materials, please ensure that CAWST is properly acknowledged. Please include our website address: www.cawst.org.

Feel free to include a link from your website to the CAWST website. Please do not host this document to download from your website as we will have updated versions from time to time. Please email us if you have any questions or feedback.

This document is open content and licensed under the Creative Commons Attribution Works 3.0 Unported License. To view a copy of this license, visit: <http://creativecommons.org/licenses/by/3.0>

You are free to:

- Share – to copy, distribute and transmit this document
- Remix – to adapt this document

Under the following conditions:

- Attribution. You must give credit to CAWST as the original source of the document

CAWST and its directors, employees, contractors, and volunteers do not assume any responsibility for and make no warranty with respect to the results that may be obtained from the use of the information provided.

Table of Contents

Acronyms	iii
Abbreviations	iii
Measurement Conversions.....	iii
Glossary.....	iv
1 Before You Start - Construction Safety.....	1
2 Latrine Instructions	5
Stage A - Obtain Tools and Materials.....	7
Stage B – Mixing Concrete.....	11
B.1 Type of Sand and Gravel	11
B.2 Where to Get Sand and Gravel	11
B.3 How to Mix Concrete.....	12
B.4 How to Test the Concrete Mix	13
B.5 How to Mix Mortar	13
Stage C – Construct Slab.....	15
C.1 About Slabs	15
C.2 Reinforced Concrete Slab	17
C.3 Dome Slab.....	21
C.4 Sanplat Platform	26
Stage D - Pit Lining	29
D.1 Poured Concrete Trench Partial Lining	30
D.2 Brick, Block or Stone Lining	31
D.3 Ferrocement Lining.....	33
D.4 Pre-Cast Concrete or Fired Clay Rings Lining.....	34
Stage E – Install Slab.....	35
Stage F – Construct Superstructure	35
Stage G – Maintenance and Follow-Up.....	35
References.....	36

Appendix 1: Preparing Sand and Gravel

Appendix 2: Sieve Set Construction

Appendix 3: Slab Mold Design

Appendix 4: Squat Hole Design

Appendix 5: Footrest Design

Acronyms

CAWST	Centre for Affordable Water and Sanitation Technology
VIP	ventilated improved pit

Abbreviations

cm	centimetre
kg	kilogram
L	litre
m	metre
mm	millimetre
"	inch

Measurement Conversions

Length or Distance

1 foot = 0.30 metres	1 inch = 2.54 cm	1 mm = 0.1 cm
1 metre = 3.28 feet	1 cm = 0.39 inches	1 cm = 10 mm

Volume

1 gallon = 3.78 litres
1 litre = 0.26 gallons

Area

1 m ² = 10.76 ft ²
1 ft ² = 0.09 m ²

Glossary

Cement	A powder (made of limestone and clay) that is mixed with water, sand and gravel to make concrete.
Concrete	A strong construction material made of cement, sand and gravel.
Corrode	When something deteriorates due to being in contact with air, water or acid.
Corrosive	The ability of a substance to chemically eat away or cause damage to another material.
Impermeable	A material that does not allow the passage of liquids.
Implementation	The process of carrying out a plan. The implementation phase happens after the plan has been created.
Infiltrate	The process of liquid slowly passing into a material such as soil.
Permeable	A material that does allow the passage of liquids.
Rebar	Steel reinforcement bar.
Sanitation	Maintaining clean, hygienic conditions that help prevent disease through services such as garbage collection, wastewater disposal, and using latrines.
Slurry	A mixture of water, cement and sand.

1 Before You Start - Construction Safety

It is important to work safely and avoid the potential for injury during latrine construction. You will be using sharp tools, lifting heavy objects, working in pits with the risk of collapse, and handling potentially dangerous materials. When properly managed, the risks involved in these tasks can be reduced to avoid injuries.

A first aid kit should be available at all times during construction. At a minimum it should have bandages, gauze and disinfectants. Medical assistance contact numbers should be posted in a visible location.

1.1 Risk in Unstable Ground



It is dangerous to excavate pits in loose unstable soil. The risk of collapse is great and the worker can be severely injured or even suffocate.

Safety Precautions for Unstable Ground

1. **Attach a rope** to the digger so that they can be pulled out if the pit collapses.
2. **Never dig alone**, always have someone at the top of the excavation to help you get out of the pit.
3. **Shore** (put up a temporary support structure) the sides of the excavation. This is especially important if you are hand digging beyond **1.2 metres**. Shoring can be made of timber or steel to support the sides of the pit during excavation and can be used until the pit lining is constructed. This adds complexity, time and cost.
4. Use **caissoning** technique (see the following illustration).
 - Dig the pit as deep as safety will allow (no deeper than 1.2 metres without shoring) place a precast concrete ring fitted with a cutting edge in the hole.
 - Place more rings on top until ground level is reached.
 - Begin excavating inside the rings. As the ground is dug away from under the cutting edge, the rings start to sink under their own weight (Franceys et al, 1992).
 - The rings will become the pit lining, therefore the bottom section should be permeable to allow liquids to infiltrate into the ground.
 - The caisson can also be built with bricks. Continue to build more layers of bricks as the caisson wall sinks.

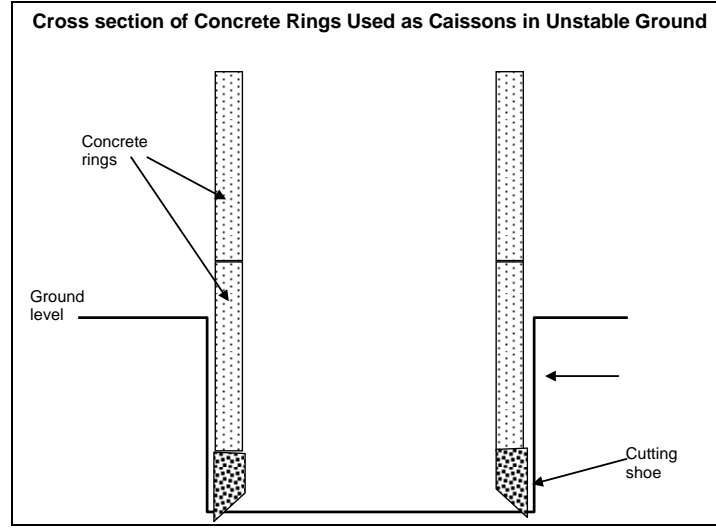

1.2 Risk Using Cement



Cement can hurt you if it comes into contact with your skin, eyes, or is inhaled. Cement dust reacts with body sweat or damp clothing to form a corrosive solution.

- Cement dust can get in your eyes, causing redness, burns, or blindness.
- Inhaling cement dust irritates your nose and throat. It can also cause choking and troubles with breathing.
- Cement is hazardous when it's wet - in mortar or concrete. If it gets inside your boots or gloves, or soaks through your clothes, it can cause burns and skin ulcers. The burns caused by cement may be slow and you may not feel anything until several hours later. That's why **it is important to wash cement off your skin right away.**

Safety Precautions for Working with Cement

1. What to wear:

- Eye protection for mixing, pouring, and other work with dry cement
- A face mask to prevent cement dust inhalation
- Work or rubber gloves
- Long sleeve shirt and full-length pants
- Pull sleeves over gloves

2. What to do:

- Work upwind from cement dust
- Remove rings and watches because cement dust can collect underneath and burn your skin
- Remove any clothing contaminated by cement
- When your skin comes in contact with cement, wash with cold running water as soon as possible. Flush out any open sores or cuts. Get medical attention if your skin still feels like it's burning.
- After working with cement, always wash your hands before eating, smoking, or using the toilet
- **If your eyes are exposed to cement, rinse with cold clean water for at least 15 minutes. Get medical attention if necessary.**

1.3 Risk Using Tools



Safely storing and using the tools correctly is the best way to prevent injuries. Use caution with sharp tools (e.g. saws) to prevent cuts. Avoid getting hit by a long handled shovel by keeping a far distance from shovel users, especially when standing behind them.

2 Latrine Instructions

The following chart is an overview of the stages that are required to build a latrine.

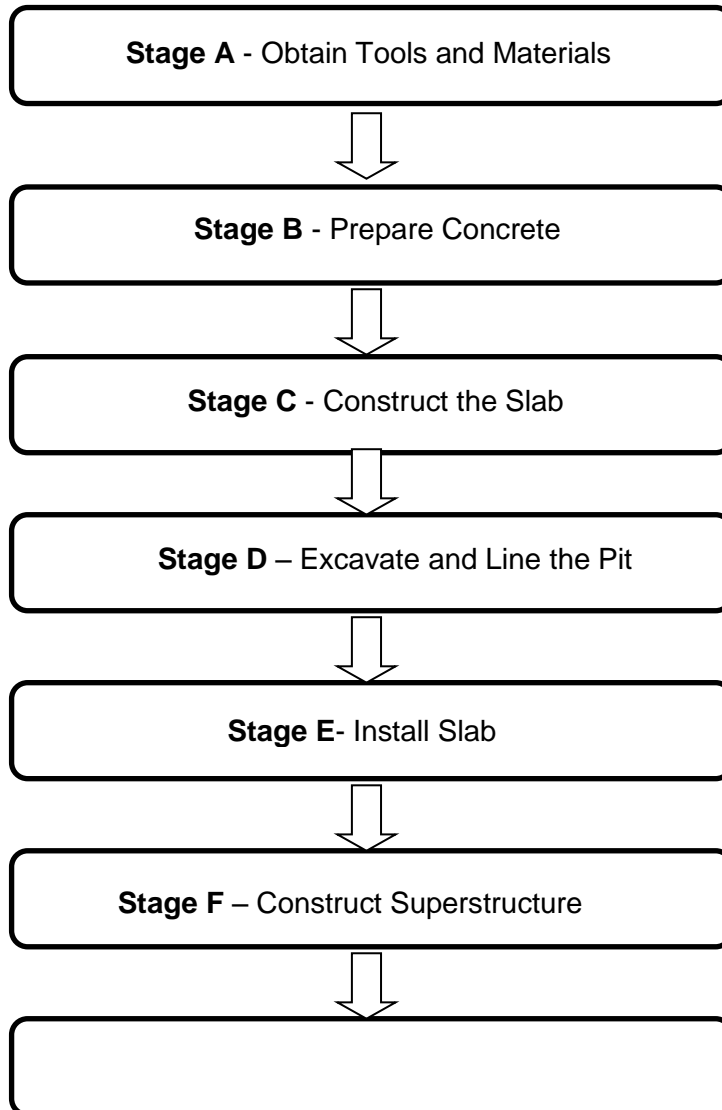

Stage G - Operation, Maintenance & Follow Up

Stage A - Obtain Tools and Materials

A good set of tools is needed to easily and properly excavate and line a pit, build a mold, and pour a slab. All you need are hand tools, which will provide you with many years of useful life if they are properly maintained, handled and stored.

You will also need to find a proper workspace that provides adequate shelter and storage for your tools, cement, sand and gravel, and slabs. To prevent theft, you may want to store your tools and materials in a locked area.

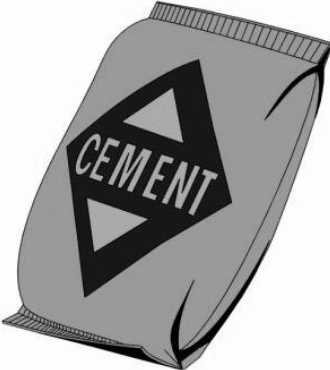

Note on Cement: Be specific about the type of cement you use. It is not recommended to use pre-mixed cement with sand and gravel, it is unlikely to be in the proportions that you need.

Depending on the country, the following are different names of cement which are all the same product: Portland Cement, White Ordinary Portland Cement, General Use Cement, General Use Hydraulic Cement, Type 1 Cement, Type 10 Cement. Make sure you are using a reputable cement company and suppliers, if you are unsure ask locals.

The cement should be fresh and not exposed to moisture. If there are lumps in the cement, it has probably been wet and should not be used. You can **NOT** break up the lumps and reuse the cement.

The tools and materials will depend on the type of pit lining and slab you choose to build. The following pages show a list of all the tools and materials that are referred to in this manual and appendices.

TOOLS

<p>Gloves - Leather</p> 	<p>Facemask</p> 	<p>Float</p> 
<p>Hack saw and blades</p> 	<p>Level</p> 	<p>1 litre measured container</p> 
<p>Buckets</p> 	<p>Paintbrushes</p> 	<p>Paper</p> 
<p>Plastic Sheets or Tarps</p> 	<p>Rags</p> 	<p>Rope</p> 
<p>Shovels</p> 	<p>Tape Measure</p> 	<p>Trowel</p> 
<p>Wheelbarrow</p> 	<p>Wire Cutters</p> 	

MATERIALS

<p>Bricks</p> 	<p>Cement</p> 	<p>Gravel</p> 
<p>Wood/Timber</p> 	<p>Sand</p> 	<p>1/2 Inch Screen/Mesh</p> 
<p>Mosquito Screen</p> 	<p>Steel Reinforcement</p> 	<p>Vegetable Oil</p> 
<p>Wire</p> 	<p>Chicken Wire</p> 	

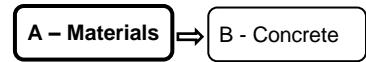

Stage B – Mixing Concrete

Proper selection and preparation of the sand and gravel is important for the strength and long life of the concrete. The process is not complicated but close attention to following the process is necessary. Poor preparation of concrete could lead to weak slabs with short lifetimes.

B.1 Type of Sand and Gravel

Use sand and gravel that is clean, hard and sharp. Make sure that there is no dirt or organic materials (leaves, grass, etc.) in it – these materials will weaken the concrete. If you are mixing concrete on the ground avoid getting dirt into the mix.

B.2 Where to Get Sand and Gravel

You may be able to buy a premade gravel and sand concrete mix if cost and availability allow. This mix may not have the right proportions of sand to gravel nor the right sizes. It is recommended to sieve these mixtures to check that you have the right proportions and sizes. Instructions for sieving sand can be found in Appendix 1 – Preparing Sand and Gravel. Instructions for building sieves can be found in Appendix 2 – Sieve Set Construction.

Gravel and Sand Sizes and Proportions

- Gravel size should be 12 mm ($\frac{1}{2}$ ") and smaller.
- Sand should be 1 mm (0.03") and smaller.
- The proportion of gravel to sand depends on the type of slab you are building. Ratios can be found under the slab construction instructions in Stage C.



B.3 How to Mix Concrete

1. Measure cement, sand and gravel according to the ratio for the slab you are building. The amounts of material will depend on the size of your slab but the ratio will always remain the same. Careful measuring ensures correct proportions.

Note: The following concrete mix ratio has been tested and proven to work.

Reinforced Concrete Slab 1 part cement : 2 parts sand : 4 parts gravel

Dome Slab 1 part cement : 2 parts sand : 3 parts gravel

For any batch size, the most important thing is to keep the proportions of the ingredients the same. You can double or triple the batch size simply by doubling or tripling the number of containers of each ingredient you add to the mix.

2. Place the concrete materials in layers on top of each other on a clean, flat surface, beginning with the gravel, then the sand, and finally the cement.
3. Mix dry ingredients together using a shovel. Make a shallow hole in the centre of the dry mix using your shovel. Pour about 4 litres (1 gallon) of water into the hole and mix it thoroughly with the dry ingredients. Mix by pulling dry material from the edges into the water.
4. When you have finished mixing the first amount of water into the material, continue to add water in small amounts between mixing and do this until the concrete reaches the proper consistency - fairly stiff and dry.

Tip: You can always add more water to the concrete mix, but you cannot take it away. The less water used, the stronger the dried concrete will be. The slab might crack if too much water is added.



B.4 How to Test the Concrete Mix

You can tell if the concrete has too little or too much water by using the blade of your shovel to make ridges in the concrete. If the mix is too dry, you won't be able to make distinct ridges; if the mix has too much water, the ridges won't hold their shape and you may notice water seeping out around the edges of the pile. In a proper mix, the ridges will hold most of their shape.



Mix the dry ingredients together using a shovel. Make a shallow hole in the centre and pour water into the hole. Mix thoroughly and continue to add water until it reaches the proper consistency.



The consistency of the concrete should be fairly stiff and dry. The filter is prone to cracks or leaks if too much water is added.

B.5 How to Mix Mortar

Mortar is a mixture of sand, cement and water. The ratio for mortar is 1 part cement to 4 parts sand (1:4). This gives you a smooth and strong material that can be used to seal joints in lining and backfilling the space between the lining and the surrounding ground.

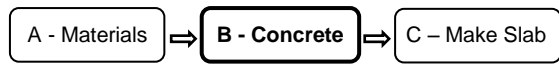

Stage C – Construct Slab

C.1 About Slabs

C.1.1 Slab Background Information

The most important design features of latrine slabs are that they:

1. Are strong enough to support the loads placed on them.
2. Safely span the pits they are designed for.
3. Are durable and long lasting.

Concrete is the most common material used for slab construction. Some benefits of concrete slabs are that they are:

- Very durable and can last for many years
- Easy to clean
- Unlikely to break if they are properly made and not overloaded

C.1.2 Slab Options: Concrete Slabs, SanPlat, Dome Slabs, Plastic Slabs

The following table provides the advantages and limitations of common slab types.

Slab Type	Advantages	Limitations
Pole and Earth Slabs	<ul style="list-style-type: none"> • Made using locally available materials • Simple to construct • Can be upgraded by plastering the floor or installing a SanPlat platform • Inexpensive 	<ul style="list-style-type: none"> • Limited life – poles will eventually rot • Earth floor is difficult to keep clean
SanPlat	<ul style="list-style-type: none"> • Relatively inexpensive • Easy to clean • Relatively durable 	<ul style="list-style-type: none"> • Requires supporting slab
Dome Slabs	<ul style="list-style-type: none"> • Less expensive than a reinforced concrete slab for the same span • Strong • Does not require steel • Relatively easy to clean 	<ul style="list-style-type: none"> • Spills run down the slab away from the drop hole.
Reinforced Concrete	<ul style="list-style-type: none"> • Easy to clean • Very strong • Very durable 	<ul style="list-style-type: none"> • Relatively expensive because of the steel rebar needed
Plastic Slabs	<ul style="list-style-type: none"> • Very easy to clean • Durable • Light and easy transport • Good option for emergency situations 	<ul style="list-style-type: none"> • Relatively expensive if imported • Small slabs require a supporting slab for strength • Easily stolen



C.1.3 Slab Sizes

The slab is often the most expensive component of a latrine. Therefore it makes sense to try to make the slab as small as possible. The minimum diameter of a slab when one person will be digging the pit is 1.1 metres. This accounts for the diameter needed for one person to excavate effectively (0.9 metres) and 0.1 metre bearing (the part of the slab that rests on the footing) around the entire edge.

The minimum diameter of a slab where two people are excavating is 1.4 metres. This accounts for the required 1.2 metre diameter to work effectively and the 0.1 metre bearing around the entire edge. In practice, the diameter of a pit, and therefore the size of the slab, will also depend on the pit volume required and the excavation depth.

Key Information



- Minimum slab size for 1 person excavating the pit (0.9 metre diameter/width pit) is **1.1 metre** diameter (circular) or width (rectangle).
- Minimum slab size for 2 people excavating the pit (1.2 metre diameter/width pit) is **1.4 metre** diameter (circular) or width (rectangle).

C.2 Reinforced Concrete Slab

Steel Reinforcement (rebars)

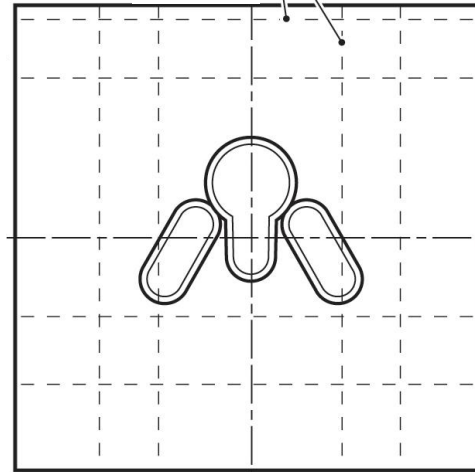

C.2.1 Reinforced Concrete Slab Design

Why Reinforce the Slab?

Steel reinforcement provides strength to the concrete. When concrete is under tension (getting stretched) it is very weak. When steel is under tension it is very strong. The combination of concrete and steel provides a long lasting slab. Below is an illustration that explains what happens to a slab without reinforcement when someone is standing on top of it. If there is steel in the slab, the cracking and failure won't occur.

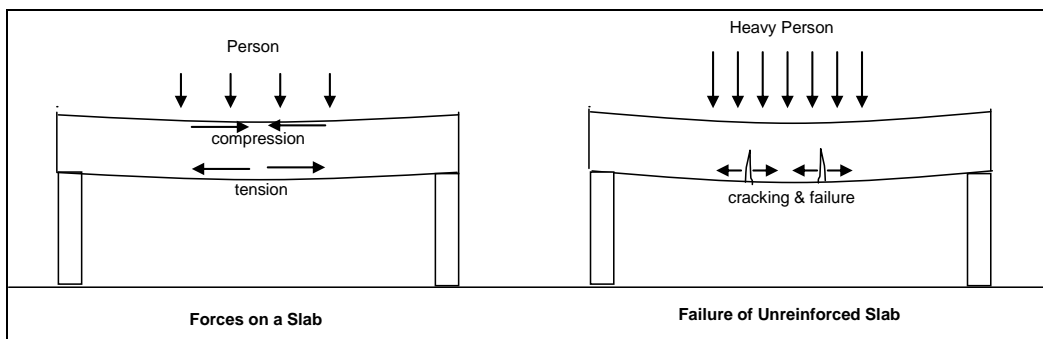

How Can You Keep Steel Strong?

Make sure that all steel in your slab is covered by at least 2.5 cm of concrete. This will increase the lifetime of your slab. When steel is exposed to water and air it corrodes, which weakens the steel.



What Size is the Slab?

The size of the slab depends on how big your pit is (see Introduction to Low Cost Sanitation Participant Manual, Appendix 2 Latrine Pit Sizing). A reinforced concrete slab can be made big or small enough to fit any size pit. The slab must have a 0.1 metre bearing around all sides (0.1 metres of the slab must rest on the footing around the pit). This means that slab dimensions should always be 0.2 metres greater than the pit dimensions.

How Much Steel is Needed?

The amount of steel reinforcement (rebar) needed depends on the span and thickness of the slab and the size of rebar being used. A greater span requires more closely spaced rebar and therefore requires more rebar than a shorter span slab. A thicker slab requires less rebar than a thin slab of the same span. The table below gives the maximum spacing there can be between bars for a given slab thickness and span.

Spacing of Steel Reinforcing Bars for Pit Latrine Slabs

Slab Thickness (mm)	Steel Bar Diameter (mm)	Spacing of Steel Bars in Each Direction for Minimum Spans (mm) of:				
		1 m	1.25 m	1.5 m	1.75 m	2 m
65	6	150	150	125	75	50
	8	250	250	200	150	125
80	6	150	150	150	125	75
	8	250	250	250	200	150

(Harvey, 2007)

How Do You Make a Mold?

Molds are typically made from wood put together with nails or slots, however they can also be made from any other material such as brick. Create a mold with locally available materials and design it so that can be reused (if you intend on making more than one slab). A reusable wooden mold design is presented in Appendix 3 – Mold Design.

C.2.2 Reinforced Concrete Slab Construction

Tools:

- Plastic sheet or paper
- Steel float
- Trowel
- 1 -2 shovels
- Gloves
- Rag or paintbrush
- Hacksaw
- Wire cutters
- Slab mold
- Block of wood for compacting
- Squat hole mold
- Footrest mold (optional)

Materials:

- Mold lubricant (e.g. oil)
- 1 part cement
- 2 parts sand
- 4 parts gravel
- Steel reinforcement (e.g. rebar)
- Wire
- Water
- Sand for making flat surface (optional)

Steps:

1. Make sure the ground you are working on is flat. If it is uneven, make a flat surface by placing a layer of sand on top of the ground and level it.

Tip: Set up your mold and fill it with sand until the sand is 6.5 cm or 8 cm (depending on the thickness of your slab design) from the top of the mold. Create a flat and even surface. Pour your slab to the top of the mold and it will be the right thickness.

2. Place paper or plastic down on the ground. This will prevent the concrete from sticking to the ground and reduce the loss of slurry into the ground.
3. Place your mold (bricks or wooden boards) on this flat and covered area.

Tip: If possible, set up your mold and pour your concrete slabs close to your pit. Slabs are heavy making it difficult and expensive to transport them a long way.

4. Place a wooden squat hole mold in the center to shape the defecation hole.
5. Optional: If creating a latrine with a vent such as a VIP latrine, a mold the shape of the vent (piece of pipe the same diameter as the vent pipe works well) can be made and placed in one of the back corners of the slab. This is where the vent will eventually be installed.
6. Cut the steel reinforcement into appropriate length and place the pieces inside the mold to create a grid.



IMPORTANT: Make sure to place the squat hole former in the mold and create the grid around it. Make sure there is a 2.5 cm concrete cover between the mold and the steel reinforcement.

7. Tie intersections of the grid together with wire.
8. Remove the grid from the mold and set aside.
9. Oil the slab mold and squat hole mold with a rag or paintbrush.
10. Measure 1 part cement, 2 parts sand and 4 parts gravel. The amounts of material will depend on the size of your slab but the ratio will always remain the same. Careful measuring ensures correct proportions.

Note: The following concrete mix ratio has been tested and proven to work.

1 part cement : 2 parts sand : 4 parts gravel

For any batch size, the most important thing is to keep the proportions of the ingredients the same. You can double or triple the batch size simply by doubling or tripling the number of containers of each ingredient you add to the mix.

11. Mix the concrete. Concrete mixing instructions are found in Stage B – Mixing Concrete.
12. Place the concrete into the mold using a shovel or container until it is half way to the top.
13. Place the tied wire grid on top of the wet concrete.
14. Pour the rest of the concrete.
15. Compact the concrete with a block of wood. This will eliminate air bubbles which can weaken the concrete.
16. Optional: Place footrest molds on the slab and pour concrete into them. Be sure to oil them first.
17. Make a slight slope towards the squat hole with the trowel.
18. Smooth the surface with a float.
19. Remove the squat-hole and vent pipe molds when the concrete begins to harden (after 1 to 3 hours).
20. Smooth the edges of the hole.
21. Allow the slab to cure for at least 7 days (preferably longer) before moving and installing it. While curing, cover it with plastic or damp cloths. Add moisture as needed. After the first 24 hours you can remove the mold, but **DO NOT MOVE THE SLAB** or it might crack.

Note: During the curing process the concrete must be kept damp. This will ensure that the strength of the concrete is maximized. Cover the concrete with plastic or damp cloths and check on it regularly to make sure it is still damp.

C.3 Dome Slab

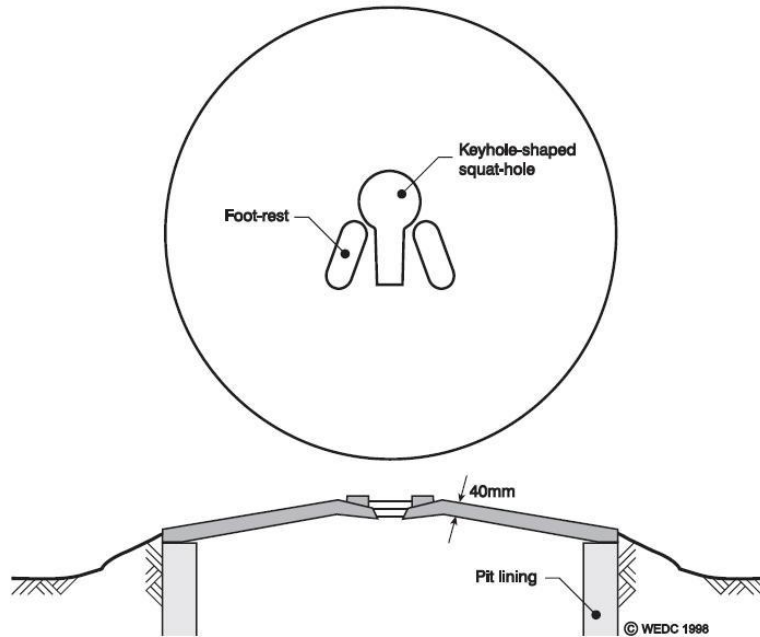

C.3.1 Dome Slab Design

Why a Dome?

A dome shape is stronger than an unreinforced flat slab because of the strength properties of a dome. The dome causes all the forces in the slab (apart from the rim) to be compressed. Concrete is very strong in compression and therefore this type of slab does not need reinforcement.

How Big Can a Dome Slab Be?

A dome slab can have a diameter of 1.1 to 1.5 metres. The size of the dome slab depends on the size of the pit. The slab must have a bearing of 0.1 metres around the edge of the pit (1 m of the slab must rest on the earth around the pit). This means that the diameter of the slab must be 0.2 metres greater than the diameter of the pit.

The height of the dome is normally 0.1 metres high at the center.



How Thick is a Dome Slab?

A dome slab is 4 cm thick. Due to the strength of the shape, 4 cm is enough concrete for a strong and long lasting slab. If you are making a slab that is 1.4 – 1.5 metres in diameter you may want to increase your thickness to 5 cm.

How do you make a mold?

A mold for a dome slab is slightly more difficult to make than a reinforced concrete slab mold. The mold design for a dome slab can be found in Appendix 3 – Mold Design. Dome slab molds are available commercially and you may be able to purchase them in the area you are working in.

C.3.2 Dome Slab Construction

Tools:

- 2 shovels
- Trowel
- Steel float
- Hammer
- Hacksaw
- Rag or paintbrush
- Dome slab mold
- Squat hole mold
- Footrest mold (optional)
- Block of wood for compacting

Materials:

- Mold lubricant (e.g. oil)
- 1 part cement
- 2 parts sand
- 3 parts gravel
- Water
- Sand for making flat surface (optional)

Steps:

1. Make sure the ground you are working on is flat. If it is uneven, make a flat surface by placing a layer of sand on top of the ground.
2. Place the metal ring on the ground/form.

Tip: Set up your mold and pour your concrete slab close to your pit. Slabs are heavy making it difficult and expensive to transport them a long way. Dome slabs are especially fragile, they can break if they are dropped or knocked.

3. Hammer the pole into the ground/form the centre of the ring.
4. Place the wooden arm on the pole.
5. Mound sand/gravel and shape it by rotating the wooden arm. Pat the sand to compact it. It may be helpful to lightly wet the sand as you shape it. At the edge of the mound there should be 4 cm between the top of the sand and the top of the metal ring. This will ensure that the slab will be the right thickness when you pour your concrete.
6. Remove the wooden arm but leave the pole in!
7. Cover the mounded sand/gravel dome with paper or plastic. This will prevent the concrete from sticking to the ground and reduce the loss of slurry into the ground.
8. Lower the squat hole mold onto the pole and rest it on the top of the mound.
9. Oil the inside of the steel ring and the squat hole mold.
10. Measure 1 part cement, 2 parts sand and 3 parts gravel. The amounts will depend on the size of the slab but the ratios will always remain the same. Careful measuring ensures correct proportions.



Note: The following concrete mix ratio has been tested and proven to work.

1 part cement : 2 parts sand : 3 parts gravel

For any batch size, the most important thing is to keep the proportions of the ingredients the same. You can double or triple the batch size simply by doubling or tripling the number of containers of each ingredient you add to the mix.

11. Mix the concrete. Concrete mixing instructions are found in Stage B – Mixing Concrete.
12. Place concrete on the mound from the bottom up. Pile concrete around the squat hole to stabilize it. The final concrete depth should be to the top of the metal ring.
13. Place the wooden arm back onto the pole and rotate it to help even out the application of concrete.
14. Compact the concrete with a block of wood. This will eliminate air bubbles which can weaken the concrete.
15. Optional: Place footrest molds on the slab and pour concrete into them.
16. Make a small level area at the top of the dome around the squat hole (for user comfort/stability) with a slight slope towards the squat hole using the trowel.
17. Smooth the concrete using the steel float.
18. Remove the squat hole former after the concrete has set for 1-2 hours.
19. Smooth the edges of the hole.

Note: During the curing process the concrete must be kept damp. This will ensure that the strength of the concrete is maximized. Cover the concrete with plastic or damp cloths; check on it regularly to make sure it is still damp.

22. Allow the slab to cure for at least 7 days (preferably longer) before moving and installing it. While curing, cover it with plastic or damp cloths. Add moisture as needed. After the first 24 hours you can remove the mold, but **DO NOT MOVE THE SLAB** or it might crack.

Dome Slab Test

1. Test every slab after a minimum of 7 days of curing.
2. Support the slab on four blocks placed diagonally at the edge of the slab (as seen in the diagram).
3. Have 6 people stand in a row across the slab.
4. Move the line of people 90° and stand across the slab in the new direction.
5. Inspect the slab. If the slab does not break and no cracking appears, then it has passed the test.

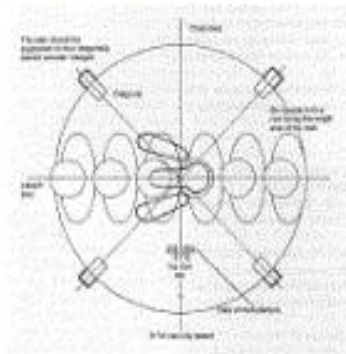



C.4 Sanplat Platform

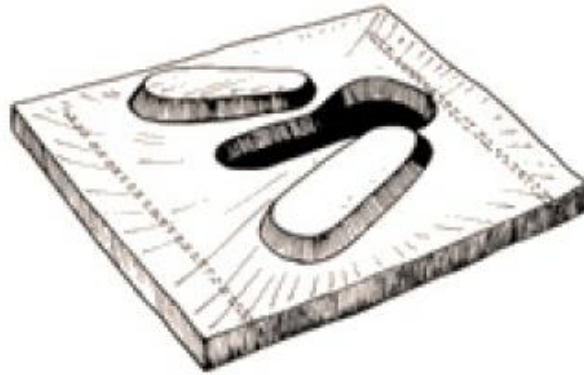

C.4.1 Sanplat Design

Why Use a Sanplat Platform?

A Sanplat platform provides a nice looking, easy to clean surface to upgrade an existing slab. A SanPlat can be placed on any type of slab (e.g. concrete, wood). It is not meant to replace a slab.

How Big is a Sanplat Platform?

A Sanplat platform is usually 0.6 metres by 0.6 metres.

How do you make a mold?

Sanplat platform plastic molds are commercially available and you may be able to purchase them in the area that you are working in. You can also build a mold out of wood or bricks the same way you can make a reinforced concrete slab mold, but with smaller dimensions. The main purpose of a Sanplat platform is to have a smooth and easy to clean surface. The plastic molds will give you very smooth surface. If you are making your own mold, be sure to lay plastic down on the bottom and stretch it out to have it as smooth as possible. After the slab is poured and has cured, you will flip the slab over and this smooth surface will become the top surface of the slab.



C.4.2 Sanplat Construction

Note: The following set of construction instructions are for a typical size Sanplat platform with dimensions 0.6 metres by 0.6 metres.

Tools:

- 1-2 shovels
- Trowel
- Steel float
- Hammer
- Rag or paintbrush
- Block of wood for compacting
- Sanplat mold
- Hacksaw (optional)

Materials:

- Mold lubricant (e.g. oil)
- 1 part cement
- 2 parts sand
- 3 parts gravel
- Plastic sheeting
- Sand for making flat surface (optional)
- Steel reinforcement (optional)

Steps:

1. Make sure the ground you are working on is flat. If it is uneven, make a flat surface by placing a layer of sand on top of the ground.
2. Oil the mold with a rag or paintbrush.
3. Mix concrete at a ratio of 1 cement: 2 sand :3 gravel (approximately 4:8:12 litres for a 0.6 m by 0.6 m platform).
4. Divide the concrete in half.
5. Add extra water to one half and place it in the mold very wet. This will provide a nice finish on the Sanplat surface.

Note: You may want to use reinforcement to strengthen the Sanplat. If you choose to use reinforcement:

1. Fill the mold half way with concrete.
2. Place reinforcement bars on opposing sides of the keyhole, evenly between the keyhole and the edge of the slab. Two pieces of rebar are adequate.
3. Fill the rest of the mold with concrete.

6. Add remaining concrete.
7. Compact the concrete with a wooden block to eliminate air bubbles. Air bubbles weaken concrete.
8. Use the float to smooth the concrete.
9. To create footrest, see footrest instructions in Appendix 5 – Footrest Instructions.



10. Cover and allow it to cure for at least 7 days.

Note: During the curing process the concrete must be kept damp. This will ensure that the strength of the concrete is maximized. Cover the concrete with plastic or damp cloths, check on it every day for the first 7 days to make sure it is still damp.

Stage D - Pit Lining

Spending the time and money to line the pit is important to:

- Prevent collapse of the pit
- Provide stable support for the slab and superstructure
- Reduce the risk of surface water infiltration, erosion and undercutting of the slab

At the very least, the top **0.5 metres** of all pit latrines should be lined. The pit can also be fully lined. The decision to line the total depth of a pit depends on the ability of the ground to support itself. **Full lining is always recommended if the pit will be emptied.**

Lining Requirements for Different Soil Types

Soils That Require Full Lining	Soils That Do Not Require Full Lining
<ul style="list-style-type: none"> • Soft sands and gravels • Unconsolidated soils • Filled land • Compressed mudstones and shales 	<ul style="list-style-type: none"> • Soils with significant clay content • Most consolidated sedimentary rocks • Soils with high proportion of iron oxides (laterites)

(Harvey, 2007)

Examine existing latrines, wells, road cuttings and other excavations to get a good idea of the ground stability in an area. Knowledge and experience of local people is also useful; collapsing ground may be the reason why there are no latrines in the area.

Key Information



- The top 0.5 metres of every pit should be lined with impermeable material (material that liquids cannot pass through) to reduce the risk of surface water infiltration to the pit, erosion and undercutting of the slab.
- Always fully line a pit if it will be emptied.

D.1 Poured Concrete Trench Partial Lining

A footing or partial lining is required for all latrines. Poured concrete provides a sturdy and long-lasting lining. Pouring a footing/partial lining before digging the full depth is one of the best ways to prevent the pit from collapsing.

Tools:

- 1 -2 shovels
- Gloves
- Measuring tape
- Long nails or stakes

Materials:

- 1 part cement
- 2 parts sand
- 4 parts gravel
- Water

Steps:

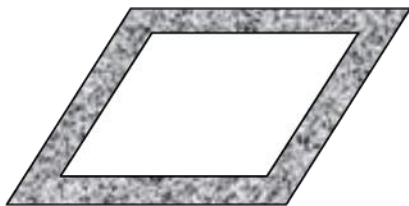
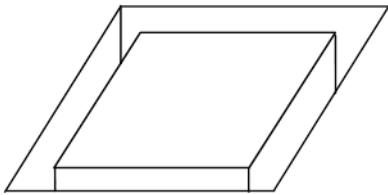
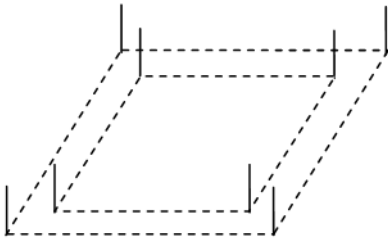

1. Clearly mark trench lines on the ground (round or rectangular). The inner dimensions should be the dimensions of the calculated pit size. The width of the trench will be the width of the shovel you are using to excavate with.
2. Excavate the trench to a minimum of 0.5 metres.
3. Mix concrete. Fill trench with concrete. Allow it to cure for a week.
4. Excavate pit, using concrete footing as a guide.

D.2 Brick, Block or Stone Lining

Tools:

- 1 -2 shovels
- Gloves
- Measuring tape
- Trowel
- Level

Materials:

- 1 part cement
- 2 parts sand
- Water

D.2.1 Partially Lined Pit

Note: Always partially line a pit to 0.5 metres deep. A pit can be left partially lined when the soil is very stable, or the consistency of clay. In other circumstances the pit should be fully lined.

Steps:

1. Add the value of the width of the lining to all sides of the pit. This will maintain the calculated capacity of the pit.
2. Dig 0.5 metres down.
3. Line the borders of the pit with brick, block or stones.
4. Use mortar to join and completely seal the bricks, blocks or stones together, use a level to make sure the walls are even.
5. Line to the top of the pit, the lining should go a little above the pit. This will help to keep surface water from going into the pit when it rains.
6. Allow mortar to dry.
7. If there is space between the lining and the surrounding ground, fill it in with clay or mortar. This creates a water resistant seal between the lining and the ground.
8. Dig the rest of the pit within the lining.

PARTIALLY LINED
LATRINE

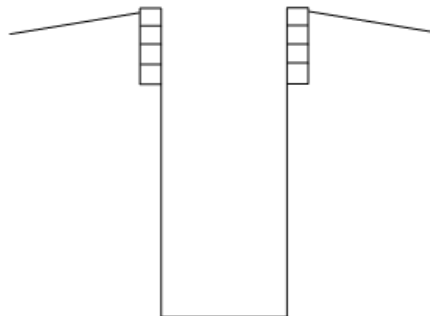

(Adapted from: Lifewater International 2009)

D.2.2 Fully Lined Pit

1. Determine the shape and size of the pit.
2. Add the value of the width of the lining to all sides of the pit. This will maintain the calculated capacity of the pit
3. Dig the entire depth of the pit. Be sure to follow proper safety precautions when digging, especially below 1.2 metres.
4. Level the bottom and clear away loose dirt and rocks.
5. Line the border of the pit with bricks.
6. Mortar every other vertical joint to allow for seepage holes. Joints in the top 0.5 meters should be completely sealed with mortar.
7. Allow mortar to dry completely.
8. Backfill the space between the lining and the surrounding ground with soil until 0.5 meters from the top. Pack the backfill with a shovel or piece of timber..
9. Fill the space between the lining and the surrounding ground in top 0.5 metres with clay or mortar. This creates a water resistant seal between the lining and the ground.

NOTE: When you begin lining, if the soil seems soft or unstable, a ring beam/foundation can be made and placed at the bottom of the pit to create a solid foundation for the lining.

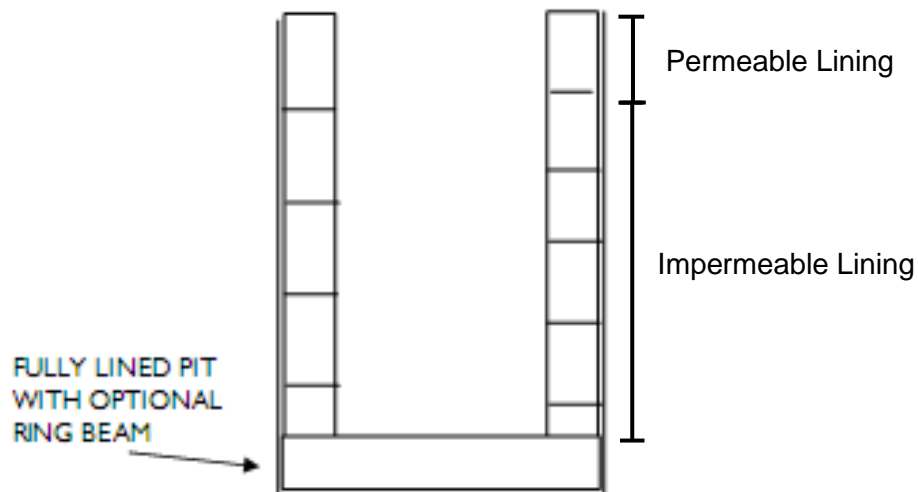

(Adapted from: Lifewater International 2009)



D.3 Ferrocement Lining

Tools:

- 1 -2 shovels
- Gloves
- Measuring tape
- Trowel
- Level
- Wire cutters

Materials:

- 1 part cement
- 2 parts sand
- Water
- Steel wire mesh (chicken mesh works well)
- Wire
- Sticks for spacers (2 cm diameter)

Partially and Fully Lined Pits:

Steps:

1. If partially lining the pit, dig 0.5 metres down. If fully lining the pit, dig the entire depth of the pit. Be sure to use proper safety precautions, especially if you are digging deeper than 1.2 metres.
2. Level the bottom and clear away loose dirt and rocks.
3. Apply mortar to the walls of the pit; make a layer that is 1 - 2 cm thick.
4. Apply 2-3 layers of steel mesh, chicken wire works well. You can keep the mesh in place by inserting long wire loops through the mesh and mortar into the soil.
5. Below 0.5 metres, put spacers in the mesh. Use short pieces of 2 cm diameter sticks inserted into mesh through the first layer of mortar. This will create the holes that are needed for liquids to infiltrate from the pit to the surrounding earth.
6. Apply a second layer of mortar and push firmly into the mesh; the layer should be 1 cm thick. The mesh should be completely covered with mortar.

(Adapted from: Lifewater International 2009)

D.4 Pre-Cast Concrete or Fired Clay Rings Lining

Tools:

- 1 -2 shovels
- Gloves
- Measuring tape
- Trowel
- Level

Materials:

- Precast concrete or fired clay rings – determine the amount of these based on the size of the rings and depth of the pit.
- 1 part cement
- 2 parts sand
- Water

Partially and Fully Lined Pits:

1. Determine the shape and size of the pit; a circular pit works best for concrete or clay rings.
2. If partially lining the pit, dig 0.5 meters down, place a ring inside the pit and dig the rest of the pit inside the border of the ring. If fully lining the pit, dig the entire depth of the pit.

Note: The caissoning technique can be used for concrete or clay ring lining. This method of excavation is recommended, especially in areas where the soil is unstable.

3. Level the bottom and clear away loose dirt and rocks.
4. Rings at the bottom of the pit should be porous, with holes between 2.5-5 cm in diameter. If holes are not an option, the joints of the rings can be held open by brick or stones to allow seepage.
5. Mortar the joints together.
6. Backfill the space between the lining and surrounding ground with soil until 0.5 meters from the top. Pack the backfill.

NOTE: If the ground at the bottom of the pit is soft, you may want to construct a concrete ring beam to use as a firm foundation for the lining.

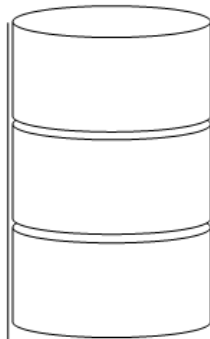

(Adapted from: Lifewater International 2009)

Stage E – Install Slab

The slab can be installed on top of the pit after it has cured for 7 days. It will take 3-4 people to transport and place the slab on the pit. Round slabs can be propped on their side and carefully rolled to the pit.

Make sure the slab is centered over the pit and that the slab has even bearing (amount of the slab overlapping the ground) on all sides of the pit. The slab should be resting on the footing.

Stage F – Construct Superstructure

Construct a superstructure around your latrine to provide privacy and security for the user. The design of the superstructure is up to you. Try to create one that is appropriate for the local setting, using local materials. Some examples of materials that can be used are wood, stone, grass, bamboo, concrete, brick and plastic. The following is a list of suggestions for your superstructure:

- Door with a lock or have a labyrinth entrance which gives privacy to the user
- Window for light and ventilation except in VIP latrines
- A light or a space for a lamp to be placed if users need to come out at night
- Any modifications required for special needs users (e.g. elderly, disabled)

Stage G – Maintenance and Follow-Up

Maintain your latrine and ensure that people will use it regularly by following the suggestions below:

- Clean the slab daily with soap and water
- Wash the floor daily using soap and water
- Keep the area around the latrine tidy and clean
- Wash the handles and lock of the latrine door daily
- Keep the hole covered while not in use to prevent mosquitoes and flies from breeding (excluding VIP latrine)
- Follow the operation and maintenance suggestions for your particular type of latrine. These can be found on the fact sheets in the Introduction to Low Cost Sanitation Participant Manual, Appendix 1 – Latrine Fact Sheets.

Over the long term, once the excreta is 0.5 metres from the top there are two options:

1. Move the slab and superstructure to a new pit. Backfill the old pit with soil.
2. Empty the pit. This can be done manually by removing the slab or opening the access door (if you are using a vault pit) and shoveling out the excreta. It can also be done by hiring a vacuum tanker to come empty it. For more information about safely emptying latrines see Introduction to Low Cost Sanitation Participant Manual, Section 4 – Latrine Design, Construction and Maintenance Guidelines.



References

Franceys, R., Pickford, J., and Reed, R. (1992). A Guide to the Development of On-site Sanitation. World Health Organization.

Harvey, P. (2007). Excreta Disposal in Emergencies. WEDC. Loughboro University, Leicestershire, UK. Available at: www.unhcr.org

Lifewater International (2009). Latrine Design and Construction. California, USA.

Latrine Construction Manual Appendix 1 – Preparing Sand and Gravel

Preparing Sand and Gravel

Proper selection and preparation of the sand and gravel is important for the strength and long life of the concrete. The process is not complicated but the steps in preparing the sand and gravel must be followed exactly as presented. Poor preparation of the construction sand and gravel could lead to weak slabs with short lifetimes.

Use sand and gravel that is clean, hard and sharp. Make sure that there is no dirt or organic materials (leaves, grass, etc.) in it – these materials will weaken the concrete. If you are mixing concrete on the ground avoid getting dirt into the mix.

Where to Get Sand and Gravel

Gravel pits or quarries are the best place to obtain crushed rock, and are common in most parts of the world. You can also ask local construction, road work, or brick manufacturing companies to find out where they get their source of crushed rock. At first, quarry rock may not seem proper for sieving due to the large amounts of dust, however, You can select the rock load and the crusher properly to ensure that large chunks of rock and dust are minimal. Often, you can even sieve the load at the quarry site and only pay for what you take. This greatly reduces waste and the cost.

Other sources are river bank sand, river bed sand and beach sand. Both river and beach sand are usually well sorted and do not have a good variety of grain sizes from very fine to large grains. A good variety of grain sizes will increase the strength of the concrete.

If cost and availability allows, you may be able to buy a premade gravel and sand concrete mix. This mix may not have the right proportions of sand to gravel nor the right sizes. It is recommended to sieve these mixtures to check that you have the right proportions and sizes.

Tips:

- You may obtain your sand and gravel from different sources.
- No matter how many different sources you use, the important factors are that you end up with construction materials that are good quality and proper sizes.
- Good quality sand and gravel are hard, clean and sharp.
- Make sure that your sand and gravel are clean.

Sieve the Sand and Gravel

Tools

- 12 mm (½ inch) sieve
- 1 mm (0.04") sieve
- Shovels
- Wheelbarrow (if available)

Materials

- Sand
- Gravel
- Face mask (optional)
- Gloves (optional)

Steps:

1. Build a 12 mm (½") sieve and a 1 mm (0.04") sieve if you do not already have them. See Appendix 2 – Sieve Set Construction.
2. The sand and gravel must be passed through the 12 mm (½") sieve and the 1 mm (0.04") sieve, in that order.
3. Sieve the material through the 12 mm sieve. Discard the material that does not pass through the 12 mm (½") sieve – it is too large to use in the concrete mix.
4. Sieve the material that passes through the 12 mm sieve using the 1mm sieve. Store the material that is captured by the 1 mm (0.04") sieve – this is used for your gravel in the concrete mix.
5. Store the material that passes through the 1 mm (0.04") sieve – this is used for your sand in the concrete mix.

Tip: Place a wheelbarrow under the 1 mm sieve. This way you will capture the sand and can easily transport it to a storage area.

Concrete Construction Sand and Gravel Sizes

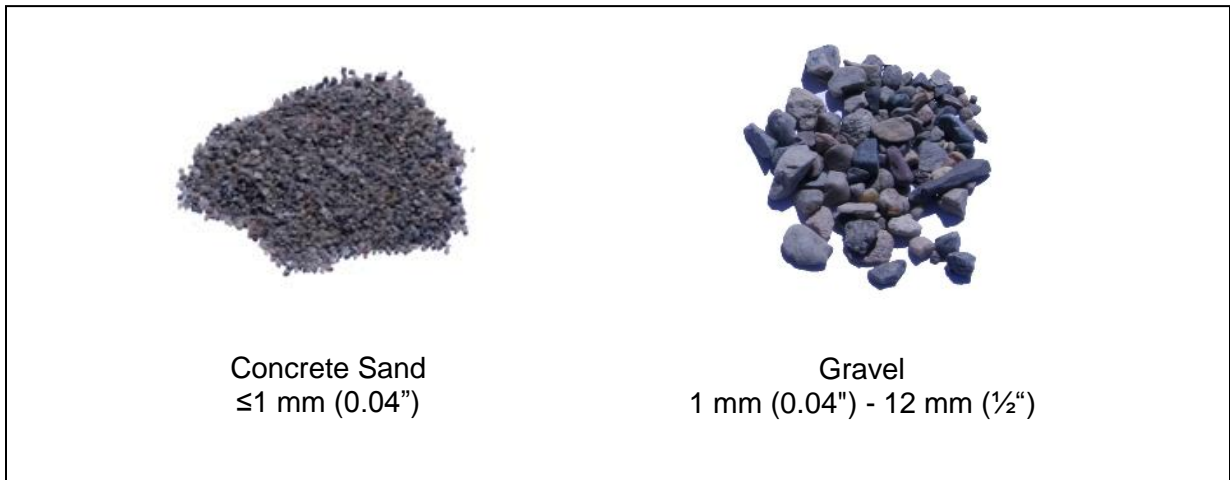
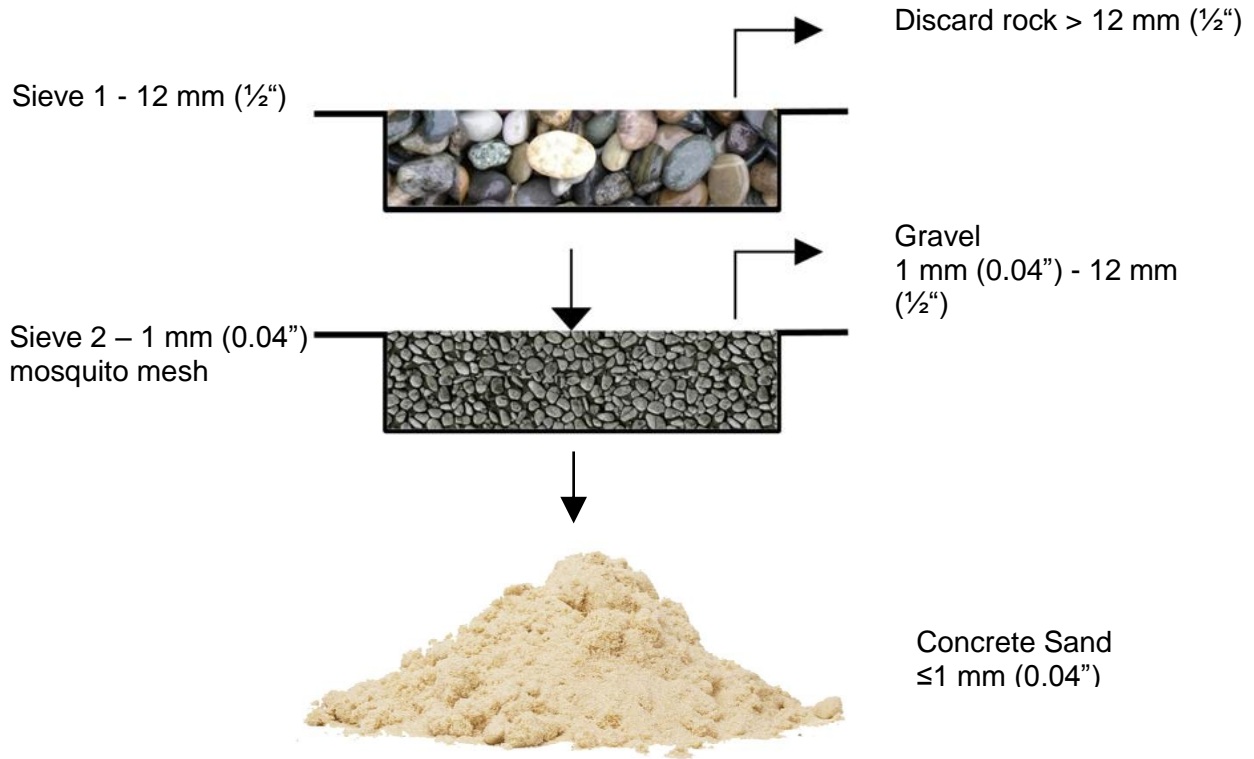

Latrine Construction Manual Appendix 2 – Sieve Set Construction

How to Build a Sieve Set

Tools:

- Hammer
- Saw
- Tape measure

Materials:

- Nails
- 1.3 cm (½") staples (if available)
- 2.5 cm x 2.5 cm (1" x 1") wood strapping
- 2.5 cm x 10 cm (1" x 4") wood
- 12 mm (½", 2 gauge) wire screen
- 1 mm (0.04") wire screen

Note:

- The mesh gauge # indicates the number of openings per linear inch (2.5 cm), therefore 4 gauge screen would have 4 openings per inch.
- Screens should be made from metal wire since it is more durable and will last longer than nylon or fiberglass. These materials are weaker and will tear easily.

Steps:

1. Construct a square frame for the sieve.

Tip: Build the frame to fit the screen!

- The suggested size is approximately 40 cm x 56 cm (16"x 22"). Two people can hold this size sieve. A smaller sieve can be constructed if only one person will be holding it. Other sizes may be constructed depending on the material available and the preference of the users.
- An organization in Brazil suspended their sieves from ropes so that they don't have to hold the weight of the sand; they only have to shake the sieve.
- The two longer sides can be made longer than 61 cm (24") to form handles.
- Don't make the sieve so large that it is too heavy to hold when filled with sand, or that the weight of the sand deforms the screen.



2. Cut a piece of screen that is larger than the frame, so that there is 2.5 cm (1") extra on all sides.
3. Centre the screen over the frame.
4. Nail staples through the screen and into the frame on all 4 sides. If staples aren't available, pound a nail in halfway, and then bend it over and pound it into the frame.
5. Bend the excess screen back on itself so that the bent edge lines up with the outside of the frame, and the excess overlaps the rest of the screen. This avoids sharp edges that could cut your hands while sieving.
6. Cut the 2.5 cm x 2.5 cm (1" x 1") wood strapping to the same lengths as your frame to form a covering frame.
7. Nail the covering frame over top of where you've nailed the screen to the frame.
8. Repeat the process until you have two sieves, each with a different screen size: 12 mm (½") and 1 mm (0.04").

NOTE:

- A well-built sieve will last for a long time so it is worth taking the time to build it well and make it comfortable to use.
- Never use a sieve that has ANY holes in the screen or where the screen is separating from the frame.
- When the screen wears out, simply remove the wood strapping, pull off the old screen and attach a new piece of screen to the existing frame.



Latrine Construction Manual Appendix 3 – Latrine Slab Mold Design

Square or Rectangle Reinforced Concrete Slab Mold

The following illustrations show one design for a reusable square or rectangle reinforced concrete slab. There are other ways you can build a mold, this is just one method. As an example, the dimensions in the drawing below will make a square concrete slab 1.1 metre by 1.1 metre. The dimensions can be changed to make any size slab.

Materials:

- 4 planks of wood
 - 2 planks the length of your slab plus 0.2 metres
 - 2 planks the width of your slab plus 0.2 metres
- Slots cut as shown to half depth of planks

The example dimensions for the square mold shown here are planks 1.3 m long x 6.5 cm tall x 2.5 cm thick.

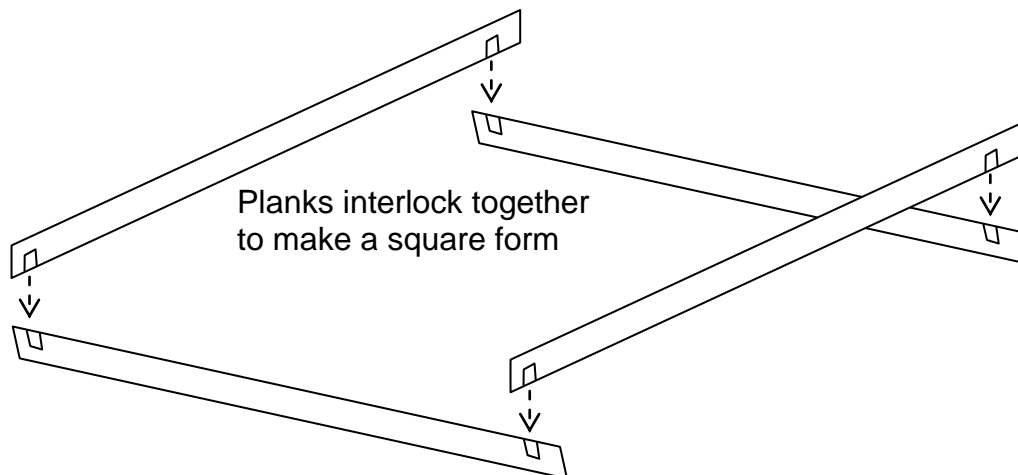
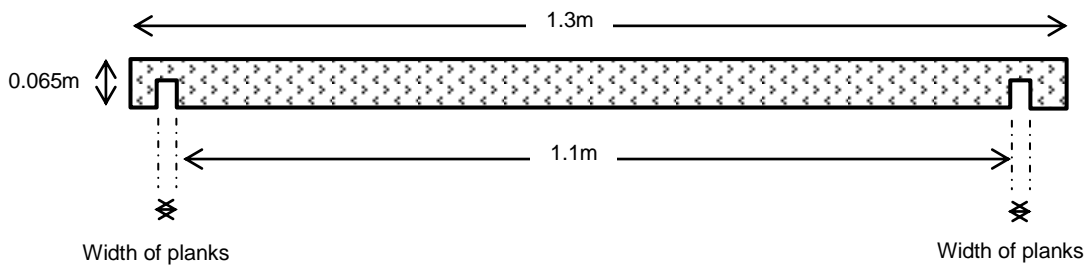

Circular Dome Slab

A circular dome slab mold can be more difficult to make than a reinforced slab mold, since there are more unique pieces. The following illustrations are for a dome slab with a 1.1 metre diameter. The dimensions can be changed to make any size slab. The recommended size for a slab dome is 1.1-1.5 metres in diameter.

Materials:

- 1 flexible steel sheet circular “girdle” 10cm wide, circumference of girdle depends on diameter of the slab being made, see table below
- 1 rotating wooden (or steel) former 5 cm thick, see illustrations below
- 1 piece of round metal bar 9 mm diameter and 0.5 m long
- Damp sand to make cone shaped base

Girdle Circumference Based on Slab Diameter

Slab Diameter (metres)	Metal Girdle Circumference (metres)
1.1	3.45
1.2	3.80
1.3	4.08
1.4	4.40
1.5	4.71

NOTE: The steel girdle can be connected by rivets or welding. If you are using rivets make sure that you have extra length of the flexible steel sheet so that you can attach it properly at the girdle circumference length.

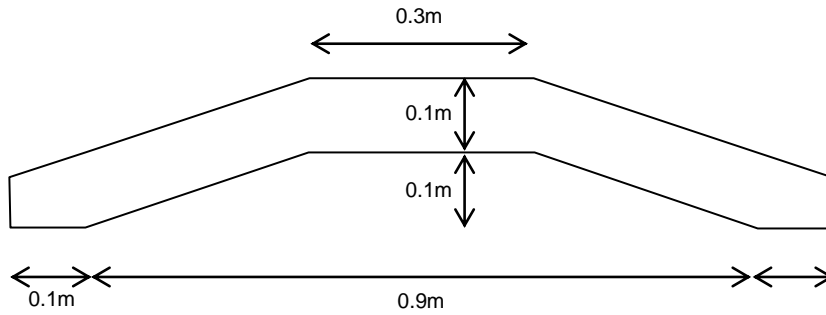

When the slab size increases the dimension showing 0.9 m will increase. All other dimensions will remain.

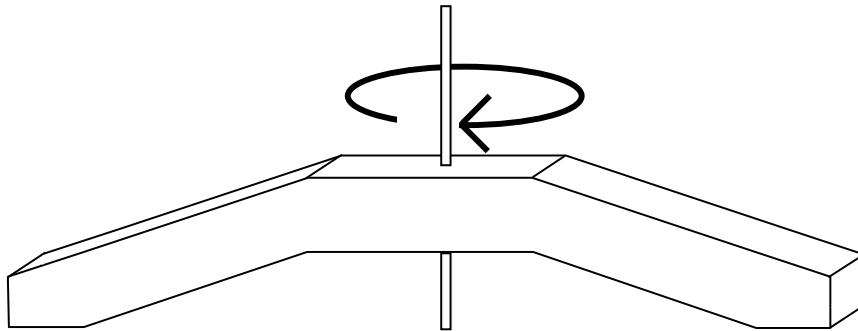

Wooden former rotates on steel bar

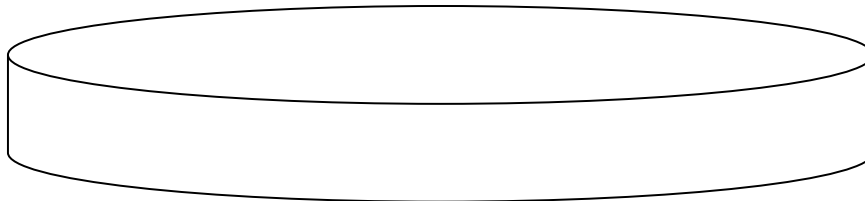

Flexible steel girdle 10cm high, circumference based on diameter of slab, in this example circumference is 3.45m

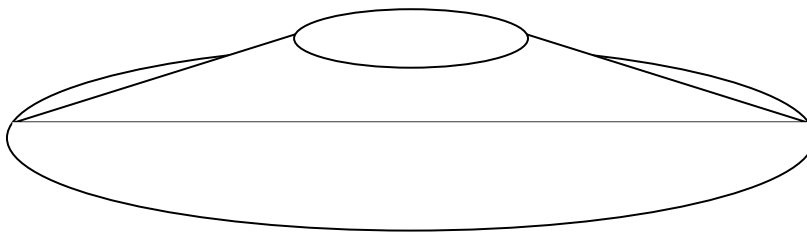

Sand shaped to form underside of slab

Latrine Construction Manual Appendix 4 – Squat Hole Mold

Squat Hole Mold

A squat hole mold is essential for a slab. Squat hole molds may be available for sale in some places, they are most often made from plastic or wood. The mold can be made by hand if none are available in your area or the cost is restrictive.

Mold Design

Squat hole molds should be made in the shape that is most common in the area, except when making a dome slab. A keyhole shape should be used in a dome slab because it is an efficient use of space and the dome requires as much concrete as possible. The keyhole shape mold for a dome slab must also have a hole drilled into the middle, the size of or bigger than, the metal pole used for the dome slab mold. The shapes shown below are possibilities for squat hole molds.

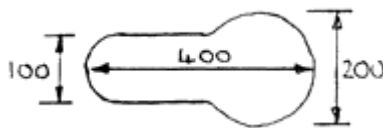
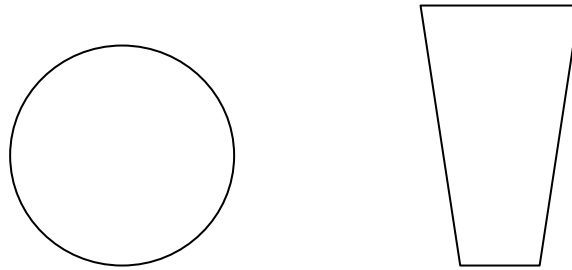

*Dimensions are in mm.

(Tearfund, 2005)

The keyhole shape mold has suggested dimensions. These dimensions are in millimeters.

Making a Mold

The mold must be thicker than the slab so that they can be taken out easily. Use your creativity to make a mold. Here are some ideas:

- Create a mold out of wood
- Use a plastic bucket
- Put a brick in a plastic bag

References

Tearfund. (2005). Planning a Pit Latrine. Available at:
[http://tilz.tearfund.org/Publications/Footsteps +21-30/Footsteps+30/Planning+a+pit+latrine.htm](http://tilz.tearfund.org/Publications/Footsteps+21-30/Footsteps+30/Planning+a+pit+latrine.htm)

Latrine Construction Manual Appendix 5 – Footrest Molds

Footrests

Footrests are preferred by some users because they can be aesthetically pleasing and provide a guide where to put your feet. Foot rests are optional for a slab and make the slab harder to clean.

Footrest molds are available for sale in some places, they are most often made from plastic. Footrests can be made by hand if they are not available in your area or the cost is restrictive.

Footrest Mold Design

Footrest molds can be made from various materials including wood and metal. There is no standard size for footrests but the following diagram provides a suggestion for size and placement with respect to the squat hole.

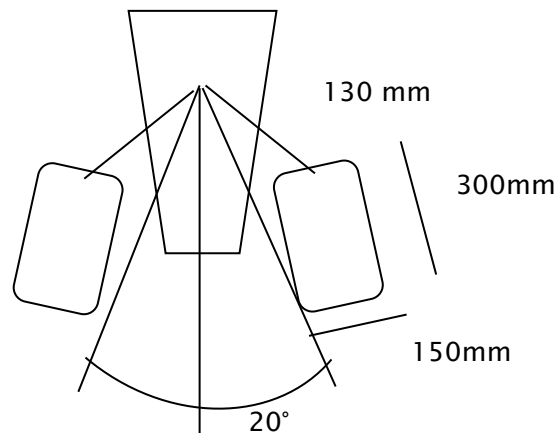

Lifewater International. 2009

- The depth of the footrest mold should be 2-3 cm thick.
- Molds should have a smooth edge. Sharp edges can be dangerous and make it difficult to clean.

Footrest Pouring Instructions

Note: The footrests should be poured at the same time as the slab.

1. Oil the footrest molds.
2. Place the footrests on the slab where you want them.
3. Score (make gashes) on the slab where the footrests are going. This will help the footrest concrete stick to the slab better.
4. Pour concrete into the footrest molds. Smooth the top.
5. Take the molds off the next day.

References

Lifewater International. (2009). Sanitation Latrine Design and Construction. California, USA.