

The Rehabilitation of People with Amputations

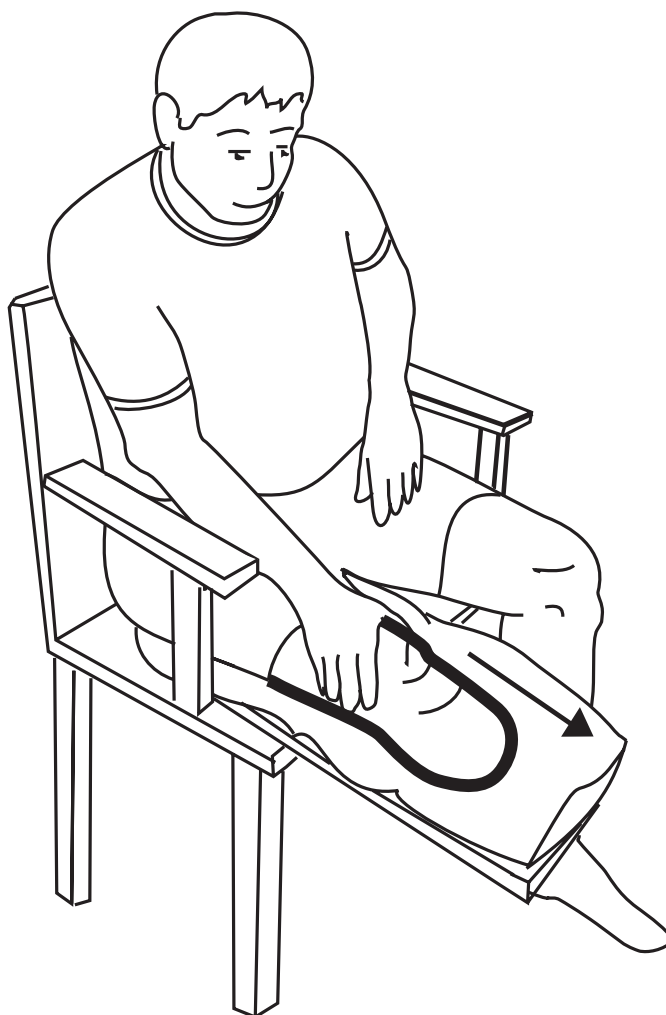

**World Health Organization
United States Department of Defense
MossRehab Amputee Rehabilitation Program
MossRehab Hospital, USA**

2004

TABLE OF CONTENTS

Introduction	ii
Forward	iii
1: Causes and Prevention	1
1.1 Causes of amputation.....	1
1.2 Levels of amputation.....	3
1.3 Prevention of amputation.....	4
2: Principles for Management of an Amputation:	8
2.1 General Principles of Amputation Surgery.....	8
2.2 Pain Management.....	12
2.3 Psychological Adjustment.....	15
2.4 Dressings.....	18
2.5 Skin Care.....	38
2.6 Exercises for the Person with an Amputation.....	42
3: Functional Activities Without a Prosthesis	56
3.1 Self Care for the Person with an Upper Limb Amputation.....	56
3.2 Transfers and Mobility for the Person with a Lower Limb Amputation.....	62
4: Information About the Prosthesis	73
4.1 Parts of the Below Knee Prosthesis.....	73
4.2 Parts of the Above Knee Prosthesis.....	77
4.3 How a Lower Limb Prosthesis is Made.....	82
4.4 The Upper Limb Prosthesis.....	85
5: Training to Use the Lower Limb Prosthesis	89
5.1 Exercises Before Walking.....	89
5.2 Walking on Level Ground Using a Support Device.....	92
5.3 Going Up and Down Elevations.....	94
5.4 Managing Prosthetic Socks.....	97
6: The Child with an Amputation	100
6.1 Causes of Childhood Amputation.....	100
6.2 Normal Growth and Development.....	101
6.3 Bony Overgrowth.....	101
6.4 Treatment.....	102
6.5 Emotional and Psychological Issues.....	104
Addendum: Daily Reminders for Persons with Amputations	105
References	107

Introduction

This manual presents information for healthcare personnel who provide care for people with amputations, e.g., mid-level rehabilitation personnel, nurses and doctors and for people who have had amputations and for their families. The content of the manual focuses on the activities a person with an amputation performs without a prosthesis (artificial limb), the basic components of a prosthesis for upper and lower limbs, and the basic training for use of the prosthesis. The manual gives information about training for self-care activities, but does not include training for household or work activities. It presents information about prostheses that is useful for the general health care personnel, as well as for people with amputations, but does not provide information on making or evaluating a prosthesis.

The content of this manual can be used in training health care personnel and can also serve as a reference for personnel working with people who have amputations. The manual, or parts of it, may be used by people with amputations and their family members for general information and as a guide to daily activities.

Limb amputations cause disabilities for men, women and children in all countries. Health care personnel can help people with amputations, their families and communities to understand the care that is needed following amputations and the process of rehabilitation that can reduce the disabilities.

With good care and training, and appropriate fitting of the prosthesis, people with limb amputations can return to previous activities, including household responsibilities, school or work.

Throughout the text of this manual the feminine and masculine forms of he and she are interchangeable. They were both used in different sections of the manual to demonstrate that anyone male or female can sustain a limb amputation.

Also, there are many different types of prosthetics and prosthetic parts used throughout the world. Many companies manufacture prosthetic parts. It is beyond the scope of this manual to review all the various types of prosthetics that can be fabricated or manufactured. For the purpose of this manual we have elected to show a representative of the basic parts of a simple prosthesis. Some of the illustrations are from Blatchford Prosthetics and were used to demonstrate basic componentry. However, we are not endorsing one brand name or type of prosthesis over another. The selection of prosthetic parts should be based on what will have the most beneficial use for the particular person with amputation and what is available to them.

Readers who want more information about the topics presented in this manual may use the list of references provided at the end of manual or contact the authors at www.einstein.edu.

FOREWORD

War and landmines are a major cause of amputation, but natural disasters, accidents and disease also contribute to the number of people who have amputated limbs. For many years, WHO has been concerned with the issues surrounding the rehabilitation of people with amputations. Previous WHO reports and documents have discussed the technology and the training of personnel to make prosthesis. We are very pleased that we now have the opportunity to present this manual on the actual rehabilitation process.

This manual is intended for health and rehabilitation personnel who work with people who have limb amputations. Personnel may also wish to give this manual to people who have amputations and their family members to help them to understand the rehabilitation process.

We are extremely grateful to the people who agreed that there is a need for this manual and took action to provide it. Amit Pandya, Director, Office of Humanitarian Assistance, United States Department of Defense (now Member of the Policy Planning Staff, Office of the Secretary of State, United States Government) was a major advocate at the United States Pentagon to raise the funds for this manual. Dr John Olsen, United States Department of Defense, who also acted as an advocate for the manual. Dr John Melvin, President of the International Federation of Physical Medicine and Rehabilitation, and Vice President for Medical Affairs, MossRehab Hospital in Philadelphia, Pennsylvania, USA, who kindly offered the services of his staff for the preparation of this manual. Dr Patricia Graham, who coordinated communication among the US department of Defense, MossRehab Hospital and WHO.

Special recognition is due to Dr Alberto Esquenazi, Chief Medical Officer, MossRehab Hospital, who both contributed to the manual and coordinated the preparation of the text and illustrations, and to the other authors:

Maria Lucas, PT	Edward Wikoff MD
Robert DiGiacomo, MPT	Susan Kahn, MSW
Nicole Kellenberger, OT	Rosa Esquenazi, MFA, illustrator
Frank Mostaccio, CP	Ronald Kalstein, MEd

We also thank Dr Ann Geordt, former WHO staff member, who worked with the authors to guide the preparation of the manual so that it is comparable to other documents produced in collaboration with the Disability and Rehabilitation Team.



Dr Enrico Pupulin
Coordinator
Disability and Rehabilitation Team
World Health Organization
Geneva, Switzerland

1

Causes and Prevention

1.1 Causes of Amputations

The exact number of people who have had amputations worldwide is difficult to determine. Many countries do not keep records of the number of people with amputations or their causes. The causes of amputation vary greatly from region to region around the world. The three main causes of amputation are disease, trauma and congenital deformities. Disease and trauma are the most common causes. Table 1 lists the percentage of amputation causes in several countries.

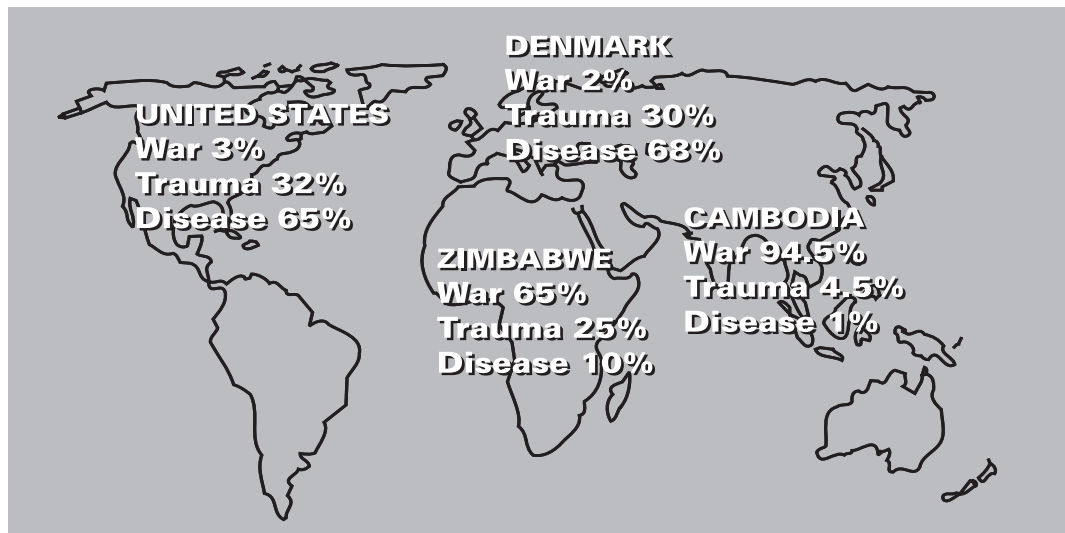

Table 1. Causes of Amputation Around the World

Country	War Related Trauma	Other Trauma	Disease
Cambodia	94.5%	4.5%	1%
Zimbabwe	65%	25%	10%
United States	3%	32%	65%
Denmark	2%	30%	68%

1.1.1 Trauma

Trauma is a major cause of amputation around the world. Again, the number of people whose amputation is due to trauma varies from country to country. In developed nations, trauma usually occurs as a result of industrial accidents, farming accidents, or motor vehicle accidents, which include automobiles, motorcycles and trains. Trauma accounts for approximately 30% of new amputations. In countries with a recent history of war or civil unrest, trauma can account for up to 80% or more of all amputations. In many of these countries landmines have become a major problem. There are over 100 million landmines in more than 60 nations around the world. United Nations Organization data indicates that mines kill or disable over 150 people each week. Often injuries involve multiple limbs, the chest, genitals and the face.

Traumatic amputations occur in a much younger and more active population than those due to disease.

Infected insect, animal and human bites and other wounds are an important cause of limb amputation, particularly in areas where antibiotics are not readily available. Inappropriate use of traditional medicines for these conditions may also increase infections that can lead to amputation.

1.1.2 Diseases

The major diseases that contribute to amputation are vascular diseases, diabetes and tumors.

In industrialized countries like the United States and Denmark, disease causes approximately 65% of all amputations performed each year. This is not true of many developing countries where trauma is the main cause of amputation. In general those individuals who have amputations due to disease are older with the amputation usually occurring after age 60.

Of the diseases that cause amputation, vascular disease with poor circulation is the most common. This disease limits the flow of arterial blood to the lower extremities causing ulcers and gangrene, which can lead to amputation.

Diabetes is another common cause of limb loss. There are an estimated 135 million people with diabetes in the world. Complications of diabetes decrease the circulation and sensation in the limbs. This can result in ulcers and infection that may lead to amputation.

Tumors of bone, muscle and skin account for a small portion of disease-related amputation. The limb where the tumor exists is removed to prevent the spread of the cancer and avoid death.

Leprosy can cause a loss of sensation in the hands and feet. Injuries to the desensitized areas can become infected and, if not treated, can lead to amputation.

Various researchers have studied the age of people who have amputations. The worldwide statistics on age related amputations are very difficult to obtain. In general, those individuals with limb loss due to disease are older with the amputation usually occurring after age 60. Traumatic amputations occur in a much younger and active population.

1.1.3 Congenital Malformation

Congenital malformation accounts for a small portion of reported amputations. In these cases a child is born with an abnormally shortened, malformed limb or no limb at all. Depending on the extent of malformation the limb is surgically removed or the shortened limb is treated like an amputation and an artificial limb may be applied. Congenital amputation accounts for up to 3 % of reported limb loss.

1.2 Levels of Amputation

The most frequent level of amputation is the below the knee amputation (transtibial) followed in frequency by above the knee amputation (transfemoral). Figure 1.1 illustrates the percentage of limb amputation at all levels.

- Through Shoulder (Shoulder Disarticulation) / Forequarter 1.5%
- Above Elbow (Transhumeral) 4%
- Through Elbow (Elbow Disarticulation) 0.5%
- Below Elbow (Transradial) 8%
- Hand amputations 2%
- Through Hip (Hip Disarticulation) and hemipelvectomy 2%
- Above Knee (Transfemoral) 31%
- Through Knee (Knee Disarticulation) 1%
- Below Knee (Transtibial) 47%
- Through Ankle (Symes or Ankle Disarticulation) 3%

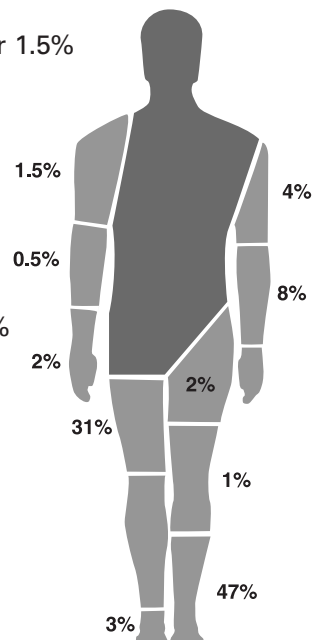

Fig. 1.1

1.3 Prevention of Amputation

As discussed in the previous section, the two most important causes of amputation are disease and trauma. The occurrence of amputation due to these causes can be reduced by education. Education about risk factors and preventative measures is the most effective tool against amputation.

1.3.1 Trauma Related Prevention

Safety: Instructing people in safety can decrease traumatic amputations. Teaching people to avoid risky behavior on the road can reduce motor vehicle accidents. People should drive at slower speeds and never drive after drinking alcohol or taking drugs. Train and bus users should be instructed to ride inside the vehicle and keep their limbs inside. Whenever the motor vehicle has seats or safety belts available, they must be used.

Amputations from work accidents result from improper use of heavy machinery and power tools. The importance of safety inspections and proper instruction in use of machinery should be emphasized to employers and employees.

Burns, electrical injuries, and insect, snake or other animal bites should be evaluated by healthcare personnel whenever possible for immediate treatment. This will avoid the complications of infection and possible amputation.

Landmines: In countries where landmines exist the removal of the mines is the best prevention. Until that happens, education can reduce the incidence and severity of accidents. Healthcare personnel should tell people about known or suspected mined areas. The workers should continually educate the people in their community, especially children, to avoid these areas. Commonly used markers are the skull and cross bone sign, an "X" or "Danger sign". (Figure 1.2) People should be instructed on how to identify land mines and the need to report them for removal. Educate as many people as possible on how to provide first aid to any victim of a landmine explosion. This will prevent death and will reduce the severity of the injuries.



Fig. 1.2

Frostbite: Tissue injury from severe cold can involve both direct freezing of tissue, and stopping of blood flow to the feet and hands. The immediate treatment is to restore the core body temperature and then rewarm the injured body part in 40 degree C to 44 degree C water over a 20-30 minute time period. Rewarming can be very painful, and people will need pain medications such as morphine. A person with frostbite should go to the hospital for treatment as soon as possible.

1.3.2 Disease Related Prevention

It is important for people with disease of blood vessels, diabetes and leprosy, to receive good medical care to manage their disease. The circulation to the extremities of these peoples should be checked frequently. Do this by feeling for pulses on the top of the foot and at the wrist. Surgery may be needed to bypass a blocked artery and avoid amputation. A person with diabetes should test his blood sugars frequently. A cooperative effort between the nurse in the community and local health centers to educate people with diabetes on the best diet and how to use medication or insulin to regulate blood sugar and how to test blood for sugar should be implemented

For people with diabetes, diseases of the blood vessels or leprosy, amputation occurs because of foot ulcers that will not heal. These diseases can cause loss of feeling in the extremities, weakness of the foot and ankle and poor blood flow to the foot. All of these conditions make the person at risk for developing a foot ulcer, but loss of sensation has been found to be the greatest risk factor.

To prevent ulcers instruct people with diabetes, blood vessel disease, or leprosy to do the following:

Shoes: Wear shoes or sandals at all times. Even when walking on sand, in water, or in the house. Shoes should have a solid bottom and fit appropriately with room for his toes. A leather top works best because it stretches to fit the foot. Using socks will help to prevent blisters. If no other shoes or sandals are available, use thongs (flip flops). Before putting on shoes, shake out any pebbles, stone or other item that may have fallen into the shoes.

Foot Inspection: Check the feet everyday for wounds or blisters by looking at them and touching them. Since loss of sensation is very common you must rely on visual inspection. Take special care to check the bottom of the foot. If the legs cannot move enough to see the bottom of the foot, use a mirror. (Figure 1.3)



Fig. 1.3

The following signs mean infection and should be checked by a doctor: Heat, redness, swelling and fever.

Other warning signs for development of ulcer are reddened areas and thick callus buildup on the bottom of the foot.

Care of the Foot: Wash the feet every day with soap and water. (Figure 1.4) Dry skin thoroughly, especially between the toes. Use lotion at night to moisturize the skin.



Fig. 1.4

Cut the toenails often. Cut straight across from side to side. Cutting the nail on a curve, increases the chance of cutting the skin. Do not cut the skin. (Figure 1.5)

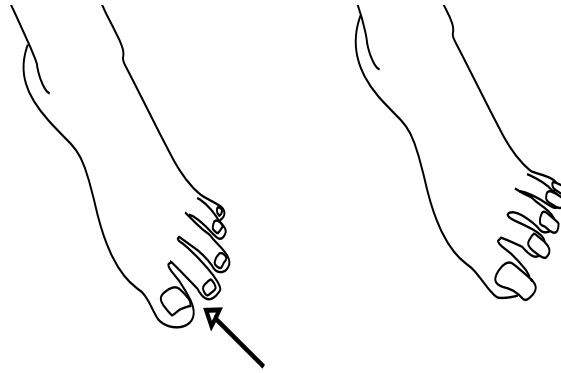

Fig. 1.5

Use of Tobacco: Smoking cigarettes and using other tobacco products is a major contributor to amputation among people who have diabetes and blood vessel disease. Tobacco acts to narrow the blood vessels and further decrease the blood flow to the feet and hands. This makes it harder for wounds to heal. Encourage all people with diabetes and vascular disease to quit smoking or using tobacco.

2

Principles for Management of an Amputation

2.1 General Principles of Amputation Surgery

The decision to amputate is an emotional process that will have life long implications for the person with an amputation and her family. Limb amputation should be seen as a means to return the person to a more functional level. The selection of the surgical level of amputation is probably one of the most important decisions that must be made. For each joint and muscle lost and replaced by an artificial limb, there will be greater cost, greater loss of function, a greater degree of impairment and increased energy cost in using the prosthesis. The ability of the soft tissues to heal themselves usually determines the best possible level for amputation. Skin bleeding is the simplest and most common way to determine this level.

After surgery, the person with a lower limb amputation may use an artificial leg to walk. Ideally for the person with a leg amputation, full body weight will be borne through the part of the limb that remains after amputation (stump). For the person with an arm amputation; lifting and pushing will be possible with an artificial limb. Bony prominences, skin rubbing, and sweating will increase the friction between skin and artificial limbs. For these reasons the stump must be surgically constructed with care. The skin and muscles are the crucial padding between the limb and the prosthesis. Promoting wound healing without joint contractures or infection is desirable. Once healing has occurred, avoiding scar tissue adhesions is an important goal of rehabilitation.

The absolute indication for amputation in trauma is a limb with unreconstructable blood vessel injury and no blood flow. Recent studies show the value of early amputation not only in saving lives, but also in preventing the emotional, marital, financial, and addictive disasters that can follow desperate attempts for limb salvage.

In the multiple limb injured person, and the elderly individual, salvage of a mangled limb even though technically possible, may be life threatening. The person may be best served by an early amputation. This is a truly difficult, but extremely important decision to make.

2.1.1 Lower Limb Levels of Amputation

Toe and partial foot amputations should only be considered when primary full skin thickness coverage can be provided. Skin grafts that have no feeling are inadequate because they can have frequent breakdowns resulting in increased complications.

In the person with poor circulation, the **below knee (transtibial) amputation** ideally should be done at the junction of the upper and the middle third of the tibia or shinbone. (Figure 2.1 and 2.2) It is important to understand that the healing rate improves when the amputation is closer to the knee, but the functional outcome decreases the shorter the limb is. People with below knee amputations will be more likely to accept and use a prosthesis than persons with higher level amputations.

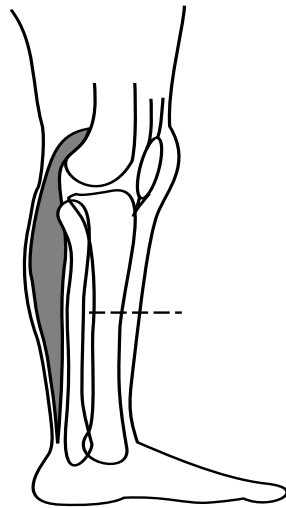

Fig. 2.1

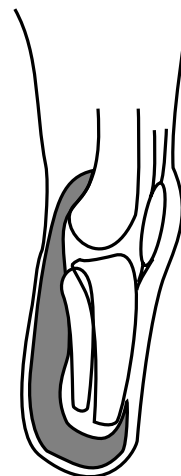

Fig. 2.2

An **above knee (transfemoral) amputation** will heal in most instances because of increased available blood supply. Unfortunately it will eliminate the anatomical knee joint, resulting in increased energy consumption during ambulation. Refer to Table 2.

Table 2. Average Increase in Energy Use During Walking with Different Levels of Leg Amputations

Level of Amputation	Energy Increase
Partial foot	10 to 20 %
Symes	0 to 30 %
Below knee	40 to 50 %
Above knee	90 to 100 %
Bilateral below knee	60 to 100%

Careful balance of the hip flexor and extensor muscles and reattachment of the distal hip adductor musculature and myodesis (muscle to muscle attachment) of other muscles should be attempted in the transfemoral or above knee amputation. (Figure 2.3 a, b) When the muscles are not reattached during surgery, this will cause the person with an above knee amputation to have an abnormal walking pattern.

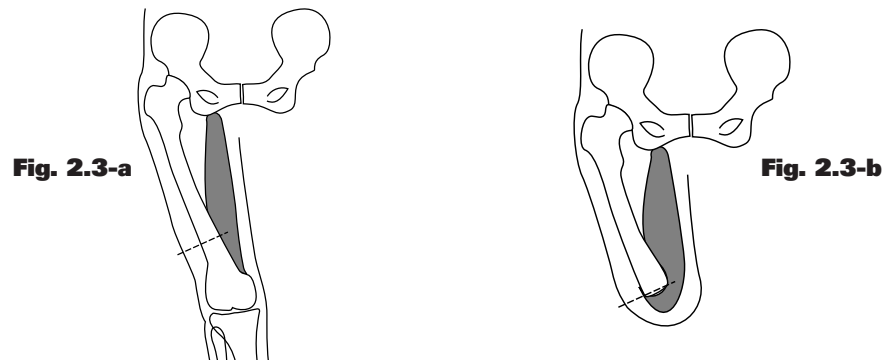

Through hip (hip disarticulation) (Figure 2.4-a) and **hemipelvectomy amputations** are seen as the result of tumors or major trauma. In these types of amputation, using crutches without a prosthesis is often the preferred way to walk.

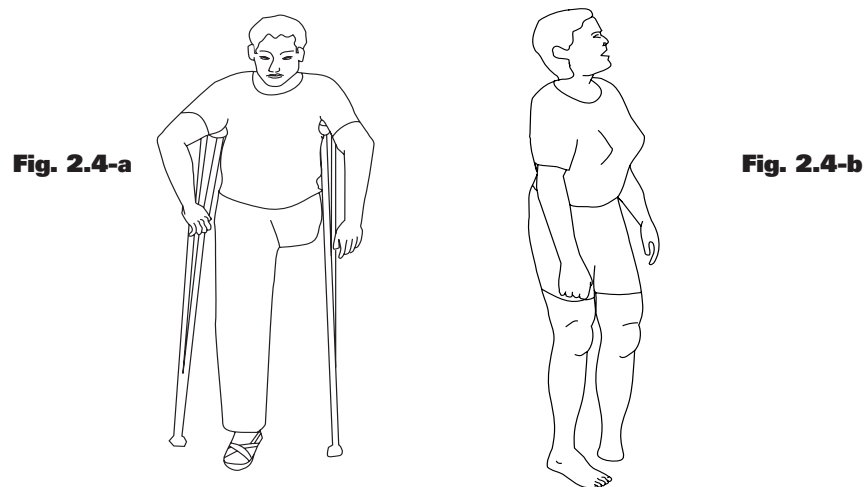

Through knee (knee disarticulation) and **Symes (through ankle amputations)** (Figure 2.4-b) may provide direct end-bearing characteristics for the limb and improved suspension of the artificial limb. They maintain the integrity of the distal musculature resulting in improved biomechanics of walking. One disadvantage of these amputation levels may be the less optimal cosmetic appearance of the prosthesis. For the bilateral lower limb amputation, when possible, the through knee amputation is more desirable than the above knee amputation.

2.1.2 Upper Limb Levels of Amputation

The preferred level of amputation when no hand function can be expected, and the most common, is the **below elbow (transradial) amputation** (Figure 2.5 a, b). This level of amputation allows the highest level of functional recovery.

Preservation of the elbow joint will significantly increase the acceptance of an arm prosthesis and its integration into functional activities. A long forearm amputation is preferred, in particular for persons who are expected to perform physically demanding work.

Fig. 2.5a

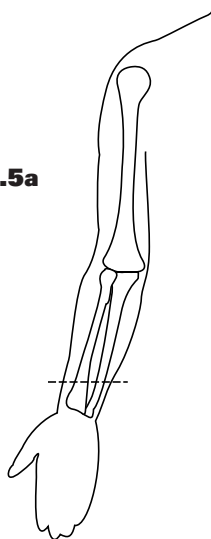
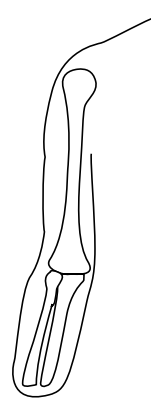

Fig. 2.5b



When the elbow can not be maintained and the person must have an **above elbow (transhumeral) amputation** it is important to preserve as long a stump as possible. This will allow the person to use a prosthetic device more easily, (Figure 2.6)

Fig. 2.6



The **through shoulder (shoulder disarticulation) and forequarter amputations** are the most difficult to fit with a functional prosthesis due to the number of joints to be replaced and the challenges suspension of the prosthesis presents. After unilateral upper limb amputation early prosthetic fitting (1 to 6 months after surgery) is imperative if successful prosthetic restoration is to be expected. After that period of time the likelihood of functional use of the prosthesis decreases.

2.2 Pain Management

Pain after an amputation can include postsurgical pain, pain after healing, prosthetic pain (caused by standing and ambulating with the prosthesis), and phantom pain (pain perceived as coming from the missing body part). The treatment for these different types of pain is quite different, so it is important to determine the specific nature of the discomfort. Each type of pain must be evaluated and treated to allow the person to function comfortably.

2.2.1 Post Surgical Pain

Postsurgical pain is the sharp, localized pain experienced by the person at the surgical site in the post operative period (generally one to four weeks following the amputation). The pain is made worse by movement of the limb, pressure in the area of the wound, or swelling (edema). This pain is to be expected and gradually resolves as the amputation wound heals.

Pain in the postsurgical period can be controlled with medications and through the use of physical modalities. Medications commonly used to relieve postoperative pain include narcotics, acetaminophen, and aspirin related drugs, such as ibuprofen and indomethacin. For the first week following the amputation, relatively high doses of medications are given. Thereafter, lower doses are needed. Physical interventions can also provide significant pain control. Swelling control contributes to wound healing and reduces pain. The limb should be elevated for one or two hours, two or three times each day to reduce local edema or swelling. Elevation should be used to control swelling and limit pain. When available, compressive elastic bandages can be worn on the stump to control swelling. An immediate post-op rigid dressing (IPORD) and edema control provides protection from mechanical trauma and reduces pain and swelling, but can only be used for clean, noninfected wounds. All wound dressings must be applied carefully (tighter distally and looser proximally) to promote swelling reduction and avoid a tourniquet effect (see Section 2.4).

The painful post surgical limb must be evaluated for other causes of pain, particularly infection. The presence of localized heat, swelling, redness (erythema), or drainage may indicate a local problem such as infection or collection of blood (hematoma).

2.2.2 Pain after Healing

Pain in the healed stump is less common and often more difficult to diagnose and treat. A good description of the pain is important, including the character, location, intensity, and duration of the pain, as well as identification of the factors which increase or reduce it. Examination of the painful limb includes inspection (looking for deformity, abnormal color, lumps, heat, skin mobility and swelling) and evaluation of strength and range of motion.

Bony causes include fracture, bone infection (osteomyelitis), abnormal bone growth (heterotrophic ossification), arthritis, and bony projections. In children under the age of 14 bony overgrowth may be evident.

Soft tissue causes of pain may include lack of blood flow (ischemia), abscess, cell inflammation (cellulitis), skin that has attached to the underlying bone (adhesions), scar formation, wasting of nerves in the limbs (peripheral neuropathy), muscle strain, pinch of the nerve (entrapment or neuroma). Treatment of the limb pain focuses on the underlying problem. Bony pathology and abscesses would require surgical intervention. Localized injection of analgesic and/or corticosteroids can be extremely effective for pain caused by arthritis, scar formation, nerve entrapment, adherent tissue, and neuroma. Ischemic pain generally requires surgical revascularization. Oral and topical analgesic medications are also used to treat limb pain. For burning pain, other medications may be much more effective and appropriate.

Physical modalities are generally helpful in limb pain. Mechanical stimulation, including massage, tapping, and rubbing, reduces local limb sensitivity. (Figure 2.7)



Fig. 2.7

Ultrasound, warm compresses, ice packs, and TENS (transcutaneous electrical nerve stimulation) are also very useful in managing residual pain. Less frequently, procedures to deaden the nerve or nerve blocks are needed for pain control.

2.2.3 Pain Caused by the Prosthesis

Prosthetic pain is generally more readily diagnosed and treated. The pain is usually mechanical in origin, frequently caused by pressure, friction or skin tractioning. When the person with an amputation can point out the location of the pain, the clinician can identify the corresponding area of the prosthetic socket. By modifying the socket in that area, the pain can generally be relieved by reducing pressure. For people with below knee amputations, the top of the shin bone (tibial tubercle), the front end and front of the shin bone (tibia), bony protrusion on the fibular side of the knee (fibular head), and muscles in the back of the knee (hamstring tendons) are common sites of mechanical pain. For people with above knee amputations, the common sites for pressure related pain are the adductor tendon, the groin area and the distal front and distal lateral areas of the femur or thigh bone. When skin breakdown occurs, the person with an amputation should avoid wearing the prosthesis until the wound heals and the cause of the ulceration is corrected. By using crutches or a walker, the person with an amputation can remain ambulatory.

Pain can also result from friction on the skin caused by the prosthesis. In this situation, the socket fit must be modified by reducing tension on the skin. This can be accomplished by using a sock made of nylon or silicone (or similar material), which will support the skin and not allow the skin to be stretched. Friction can occur when the suspension of the prosthesis is not enough or there is insufficient thickness of prosthetic socks allowing the prosthesis to piston up and down. ***For more information about managing prosthetic socks refer to Chapter Five.***

Traction pain is caused when the limb is bulbous or wider at the bottom than the top. To decrease pain due to this, a hole can be placed in the bottom of the prosthetic insert or socket and a cotton or nylon pull sock can be used to draw the soft tissue deeper into the socket by pulling the limb into the socket, reducing proximal friction and traction. Traction pain can also occur when the bottom of the stump does not touch the bottom of the socket and there is a space. If this happens add a pad to the inside of the socket.

2.2.4 Phantom Limb Pain

Most people who have had an amputation experience phantom sensation, described as the feeling of the missing part of the limb. This requires no treatment but some people will also feel pain coming from the missing limb which is known as phantom limb pain. The pain is often described as a cramping or twisted posture of the missing limb. If a painful wound was present prior to the amputation, the phantom pain may mimic the pain of that lesion. Phantom limb pain is difficult to treat, causing frustration for the person with an amputation and care givers alike. Treatment for phantom pain should begin with touch (tactile stimulation) and biofeedback. Massage, rubbing, and tapping may provide relief. Ultrasound and TENS have also worked in certain cases. The person with an amputation can often achieve better success by using brain imagery to activate the nerves and muscles of the stump to create the feeling of movement in the phantom limb, for example, wiggling the toes or bending the ankle or knee in the limb that is no longer there. Medications are used frequently to treat phantom pain, with inconsistent results.

With a wide variety of treatment options available, treatment of pain must begin with accurate diagnosis. Once the nature of the person's pain has been clarified, then appropriate interventions can proceed.

2.3 Psychological Adjustment

Most people with a new amputation know very little about limb amputation surgery and how it will affect their lives. Providing information is important to reduce the person's and the family's anxiety, obtain cooperation in the treatment program, and to help the person with an amputation to adjust to his new condition.

The person who experiences an amputation requires the use of social support systems, especially if the rehabilitation process will be a long one. Persons with close family relationships, strong religious beliefs and caring friends seem to deal with their loss better than those without social support.

The adult who experiences the loss of a limb often faces overwhelming feelings of losing control and of being dependent. Most people with amputations describe a feeling of complete change in reality due to lack of function, alteration of limb sensation, change in body image and lack of understanding of medical treatments.

2.3.1 The Grieving Process

The person will frequently go through a grieving process similar to when a loved one dies. There are five stages of the grieving process: denial, bargaining, anger, depression and acceptance. In the first stage the person with a new amputation obviously is unable to deny the physical loss, but may deny that the loss will change her life in any significant manner. In the second stage, the person may bargain with any individual they believe has control over her physical well being. During the third stage the person may get angry toward almost any one or anything. For example, the situation responsible for the amputation, the medical personnel who could not save the limb or herself for being reckless. Once the person understands the reality of the loss and its' implications, depression begins. Emotions that range from crying to withdrawal, loss of appetite and difficulty sleeping will frequently appear. At the end of this stage the person feels anxious about the effect the amputation will have on daily living. In the fifth stage, she starts to adapt to the physical loss of the limb and begins to make adjustments in her activities of daily living. Finally, she starts to accept the loss of the limb and may no longer view it as a tragic situation.

Some people experience grief for a period of time, start their adjustment and then return to the earlier stages again. Others will appear to skip stages or may seem stuck in one stage of grief. Encouraging a person with an amputation to discuss his feelings openly helps him to relieve the anxiety and allows him to identify ways to approach his condition. Health personnel can also utilize this information to help the person determine the kind of support he will require. How a person with an amputation sees himself and how others perceive him, in particular his altered body image, is an important issue to explore. People who lose their limbs to disease have already adjusted to the loss of a perfect body. For them, amputation can bring feelings of relief from suffering and return to a more "normal" level of function or it can be perceived as approaching death that medical procedures can no longer control. A person who loses her limb due to trauma has a more abrupt change in body image. She will experience more difficulty going from a healthy, intact body to one that is perceived as "less than whole". She may have a fear of being seen in public or having the amputated limb exposed in public. Attempts should be made to encourage the person to adjust to being seen by others. An outing into the community with the someone to support her can be helpful.

2.3.2 The Family

The spouse of an individual with a recent amputation also experiences a series of losses and adjustments. The spouse initially fears that the individual will die. This is followed by a fear of living with a person with

a serious injury and a concern about accepting a person with a changed body. The spouse may experience the need for escape, loss of sexual arousal, revulsion, fear of ongoing economic dependency. The person with an amputation may fear his inability to assume new roles within the family while they are consumed with grief. The change in function that results from amputation may require a total shift in responsibilities. The financial and emotional burdens can be overwhelming. For many couples this can cause serious strain on the relationship. Elderly individuals may view themselves as a burden to their children and useless to society.

2.3.3 Treatment

Psychological treatment interventions should address both the person with an amputation and the family. It is important to provide a supportive environment where the person can discuss his feelings of loss and fears for the future. Some attempt should be made to support the person as he reenters society and to continue to discuss with him his changed body image and how people may react poorly to him in public.

An excellent way to give persons with amputations psychological support is through peer counseling or support groups. Every attempt should be made to have a person of similar age and type or level of amputation speak with a person with recent amputation.

Whenever possible the person with an amputation should be encouraged to return to work or previous life roles. If this is not possible, finding new roles for the person with an amputation will also help him to see that he is useful and that he does still contribute to society.

2.4 Dressings

Dressings are used immediately after amputation surgery and continue for up to six months or more after surgery. Dressings are used to provide a clean, protected environment for the wound and to control postoperative swelling through gentle compression. If used correctly for an extended period, dressings will better shape the stump to use a prosthesis.

Goals of Dressings:

1. Protect the surgical wound from any forces that may cause the reopening of the incision.
2. Maintain a clean wound and prevent wound infection.
3. Control postoperative swelling.
4. Prevent limb contractures or muscle tightness that limits the motion of the joints.
5. Shape the amputated limb into the form of a cylinder which works best with artificial limb socket fitting.

Types of Dressings:

The three most common forms of dressings used for a person with an amputations are:

1. Soft
2. Rigid
3. Rigid removable

2.4.1 Soft and Elastic Dressings

These stump wrappings use nonrigid, preferably elastic materials, to accomplish the goals of dressings. Soft dressings use easily obtained materials, but require some skill by clinicians and the person with an amputation to put on, The wrapping is re-applied every 3-4 hours. The wrappings must be kept clean.

When to use a soft dressing:

1. When the surgical wound needs to be checked often.
2. When significant wound drainage is present, requiring frequent changes.
3. When bandaging materials are readily available.
4. When a caregiver has little skill with the application of a rigid dressing.
5. When materials for rigid dressing are not available.

Fig. 2.8 Materials you can use for soft dressings:

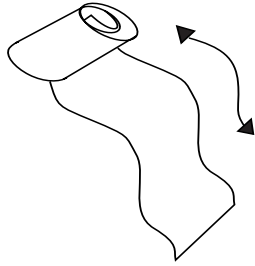

Elastic bandages

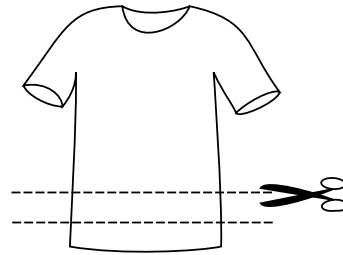

Strips of cloth

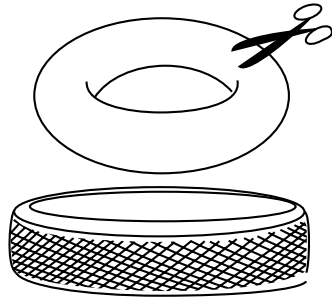

Strips of rubber innertube



Large, sturdy leaves

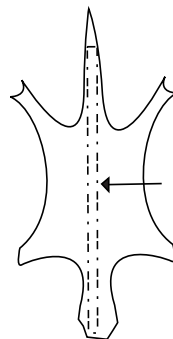

Animal hide

Some different methods of wrapping stumps are shown on the following pages.

Below knee amputation: *Use of cloth or elastic bandages (10-15 cms)*

1. Start the wrap on the front of the leg and wrap to one corner of the end of the limb; come around the back of the leg to the other corner. Cross to the front and continue upward in the direction of the back of the knee. (Figure 2.9-a)

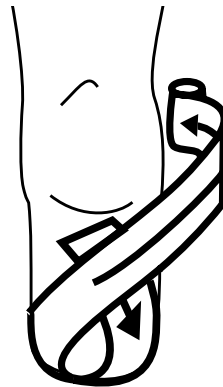

Fig. 2.9a

2. Continue the wrap behind the knee, and come back to the front, above the knee. Wrap across above the knee cap. (This is the only wrap not on an angle, it should be looser than the other wraps) Continue behind the knee and come across the front of the leg, downward towards the uncovered skin on the opposite side of the limb. (Figure 2.9-b)

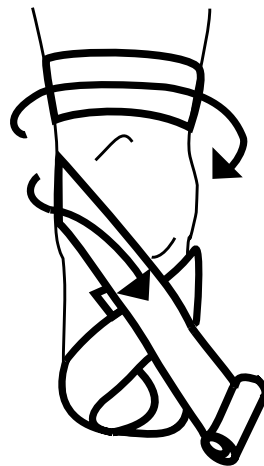

Fig. 2.9b

3. Go around the back and come up to the front of the leg covering exposed skin on the end of the limb. Continue to the back of the leg, just below the knee. (Figure 2.9-c)

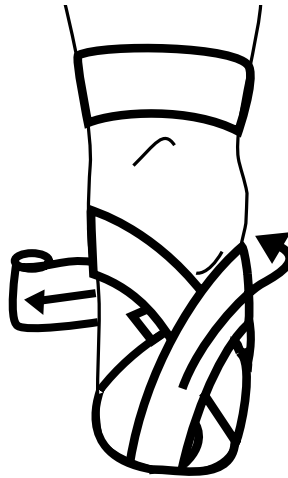

Fig. 2.9c

4. Come across the front again, covering any open skin and aim for the opposite corner of the limb. Continue wrap behind the leg and come up to the front from the other corner of the limb, cross over and again pull towards the back of the leg. (Figure 2.9-d)



Fig. 2.9d

5. Continue this wrapping method which forms an "X" in the front of the limb with the dressing. Wrap until the entire limb is covered and then attach the end of the wrap. Rewrap after loosening, when gapping occurs, or every four hours. (Figure 2.9-e)

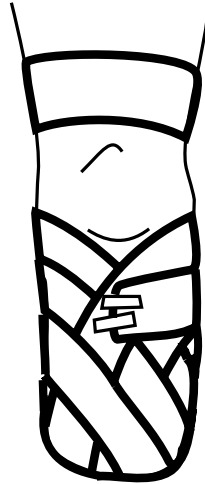

Fig. 2.9e

Things to remember when wrapping:

- 1 Wrap fabric snugly to prevent wrinkles or loosening.
- 2 Wrap in a diagonal pattern, not in circles.
- 3 Spread the layers out evenly top to bottom.
- 4 Make the wrap tighter at the bottom than the top.
- 5 Always wrap up to the level of the knee and above.
- 6 The wrap will need to be re-applied about every 4 hours.

Below knee amputation: Use of leaves

When elastic bandage or fabric is not available, another option is to use large, durable leaves or strips of clean rubber innertube at least 20 centimeters long. Again, cover all open areas (wounds) with clean bandages before wrapping.

1. Take the first leaf and wrap the front and back of the amputated limb and hold in place. (Figure 2.10-a) *Note: Try to conform the leaf to the shape of the limb.*

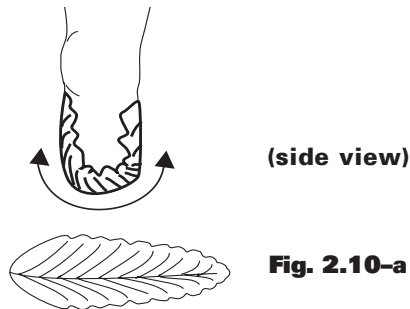

2. Next, take a second leaf and wrap the outside and inside of the limb. (Figure 2.10-b)

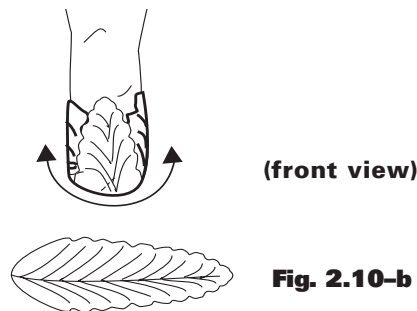

3. Now attach both leaves snugly with a belt, length of fabric or a long, thin leaf without cutting off blood flow. (Figure 2.10-c) *Note: Leaves should be replaced when they have dried out and reattached when they are loose.*

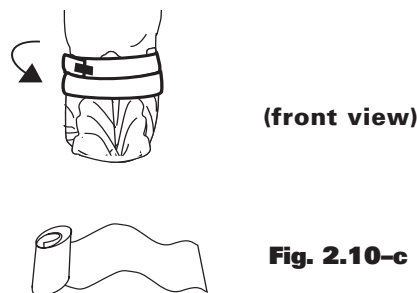

Above knee amputations

Use of cloth or elastic bandages (10-15 cms width)

1. This wrap is applied with the hip straight. The wrap should not pull the hip into a bent position. Begin on the front of the amputated limb by wrapping from the middle to the inside of the leg, aim downward behind the leg, around the back and again across the front of the leg. (Figure 2.11-a)

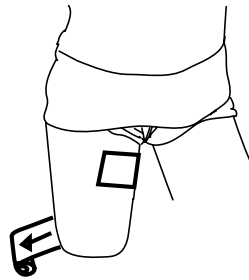

Fig. 2.11-a

2. Continue diagonally upward wrapping to the top of the leg and cover the inner groin area. Note: It is very important to cover all of the skin in the groin to prevent the formation of a hardened roll of skin that can be painful. Go around the back of the leg and then across the front to cover the groin area just below the first wrap. (Figure 2.11-b)

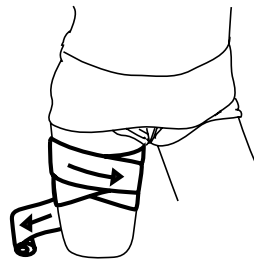

Fig. 2.11-b

3. Progress down to the back end of the limb. Come up from the corner of the limb across the front of the leg and head up towards the opposite side of the pelvis. Wrap around the back of the pelvis. (Figure 2.11-c)

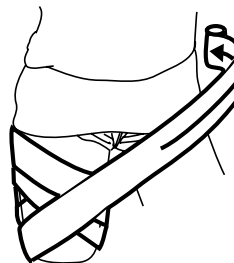

Fig. 2.11-c

4. From the other side of the pelvis continue the wrap across the front of the limb and cover the inside corner of the end of the limb. (Figure 2.11-d)

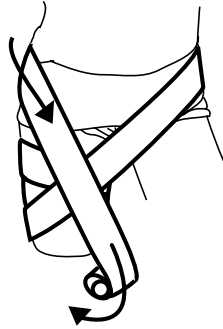

Fig. 2.11-d

5. Continue wrapping the limb until all skin is covered. It may require more than one wrap to cover the limb. Secure the end of the wrap to itself. Rewrap after loosening, when gapping occurs, or every four hours. (Figure 2.11-e)

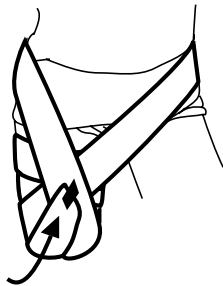

Fig. 2.11-e

Things to remember when wrapping:

1. Wrap fabric snugly to prevent wrinkles or loosening.
2. Wrap in a diagonal pattern, not in circles.
3. Spread the layers out evenly top to bottom.
4. Make the wrap tighter at the bottom than the top.
5. Always wrap up to the level of the groin. It is very important to include all of the skin and tissue of the inner thigh and groin area.
6. The wrap will need to be re-applied about every 4 hours.

Below Elbow

Use of cloth or elastic bandages

Teach a person who has a below elbow amputation to wrap the limb using the elbow pressed against the body or foot to stabilize the end of the wrap to start.

1. Stabilize the end of the wrap as described. Start the wrap on the front of the arm and cover the inside corner of the limb. Continue around the back of the arm to the outside corner. (Figure 2.12-a)

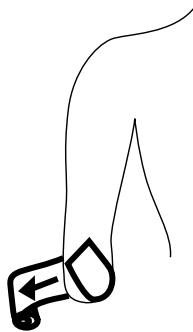

Fig. 2.12-a

2. Come around to the front and wrap across and upward to just below the elbow. Continue the wrap behind the elbow. (Figure 2.12-b)

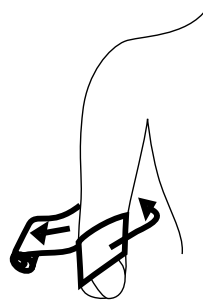

Fig. 2.12-b

3. Come around the front and wrap straight above the elbow crease. This is the only straight wrap you should have. Make this wrap looser than the other wraps. Continue behind the arm. (Figure 2.12-c)

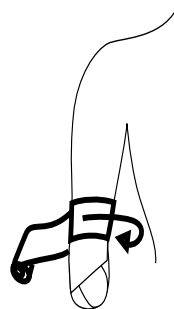

Fig. 2.12-c

4. Around the front continue to wrap downward in front of the elbow to the opposite side and bottom of the arm. Cover any exposed skin and proceed behind the elbow again. (Figure 2.12-d)

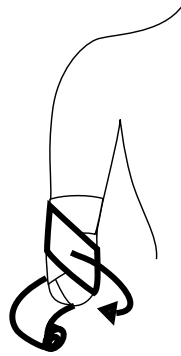

Fig. 2.12-d

5. Come up from the opposite corner of the limb, go across the front of the arm and then go behind one last time. Adhere the end of the wrap to itself. (Figure 2.12-e) Rewrap after loosening, when gapping occurs, or every four hours.

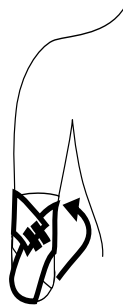

Fig. 2.12-e

Things to remember when wrapping:

1. Wrap fabric snugly to prevent wrinkles or loosening.
2. Wrap in a diagonal pattern, not in circles.
3. Spread the layers out evenly top to bottom.
4. Make the wrap tighter at the bottom than the top.
5. In the ***below elbow*** amputation always wrap above the elbow.
6. The wrap will need to be re-applied about every 4 hours.

Above Elbow

Use of soft or elastic bandages

After surgery, a person who has an above elbow amputation will most likely need a caregiver to wrap his limb. Eventually, the person with an amputation can learn to wrap his own limb using his underarm or chin to stabilize the end of the wrap initially.

1. Stabilize the end of the wrap as described. The caregiver or person with an amputation can begin on the front of the arm and start wrapping from the middle diagonally downward to the inside half of the distal limb end. Continue the wrap behind the arm. (Figure 2.13- a)

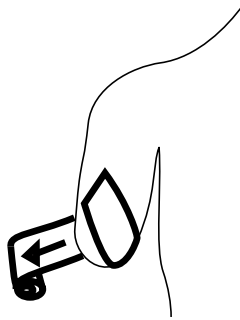

Fig. 2.13-a

2. Come back to the front of the arm, cover the end of the wrap and continue up to just below the armpit. Continue the wrap around the arm toward the opposite limb end. (Figure 2.13-b)



Fig. 2.13-b

3. Wrap up from the corner of the limb end and wrap across the arm covering any exposed skin. Again, go around the arm. (Figure 2.13-c)

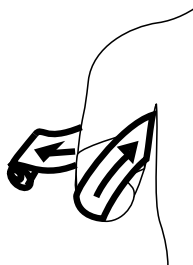

Fig. 2.13-c

4. Come across the arm from just below the shoulder cover any remaining open tissue. (Figure 2.13-d and e)

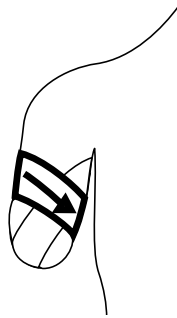

Fig. 2.13-d

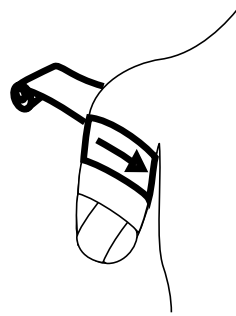

Fig. 2.13-e

5. Go across the chest and under the other arm and adhere the wrap to itself. Rewrap after loosening, when gapping occurs, or every four hours. (Figure 2.13-f) If the above elbow stump is very short use the wrap around the chest to pull the limb down against the trunk. This will avoid a contracture of the arm out to the side.

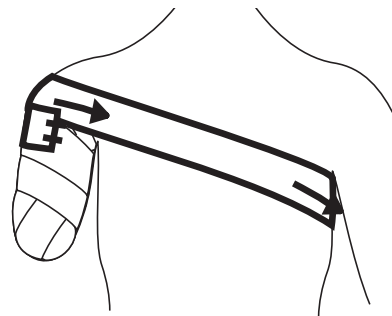

Fig. 2.13-f

Things to remember when wrapping:

1. Wrap fabric snugly to prevent wrinkles or loosening.
2. Wrap in a diagonal pattern, not in circles.
3. Spread the layers out evenly top to bottom.
4. Make the wrap tighter at the bottom than the top.
5. In the ***above elbow*** wrap around the chest.
6. The wrap will need to be re-applied about every 4 hours.

2.4.2 Rigid Dressing

A rigid dressing uses rigid casting material, such as plaster of Paris, applied immediately after surgery, and kept in place for 5 - 7 days. Three to four repeated applications are necessary, or until full healing occurs. *This procedure is recommended for below knee or below the elbow amputees only.*

Advantages of a rigid dressing:

1. Protects the stump from trauma.
2. Reduces stump pain.
3. Allows for early weight bearing.
4. One of the best ways to control swelling.
5. Keeps good Range of Motion (ROM) of the knee or elbow.

Disadvantages and contraindications for rigid dressings:

1. The person with an amputation must be monitored frequently for a 2 to 4 week period or until healing occurs.
2. The incision cannot be inspected on a frequent basis.
3. Best to use when the cause of amputation is trauma and there is no underlying disease process.
4. Casting materials and a skilled person to apply the cast must be readily available.
5. Cannot be used with an infected incision wound.

Materials to use for rigid dressings (Figure 2.14):

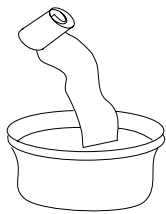

Plaster of Paris

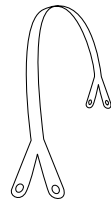

Shoulder harness
made from cloth,
leather or suspenders

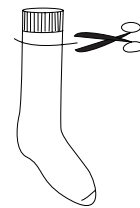

sock or stocking

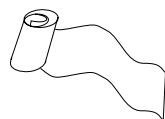

Cloth, cotton or
gauze pads

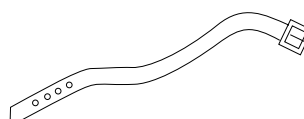

Belt

How to make a rigid dressing:

1. Start by putting a long sock over the limb to above the knee or elbow. (Fig. 2.15-a)

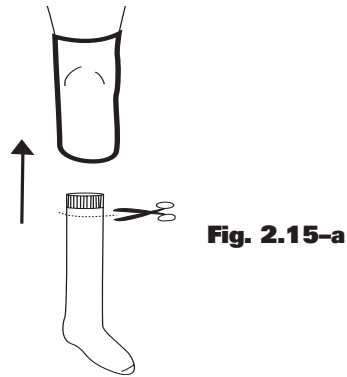

Fig. 2.15-a

2. Place gauze pads on either side of the shin bone (tibia). Also place pads over the bony areas just below the knee cap (medial plateau) and on the outside of the leg(fibular head). (Fig. 2.15-b) On the arm, place gauze pads over the bony part of the elbow.

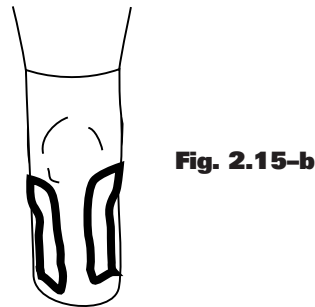

Fig. 2.15-b

3. Next, attach the suspenders to the top of the sock leading up the thigh and attach that to the belt that goes around the waist. (Fig. 2.15-c)

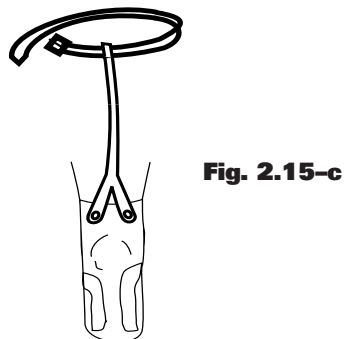

Fig. 2.15-c

4. Cover the limb with several layers of gauze wrap or any cloth material. Be sure to add extra layers to the bottom of the limb for added cushioning. (Fig. 2.15-d)

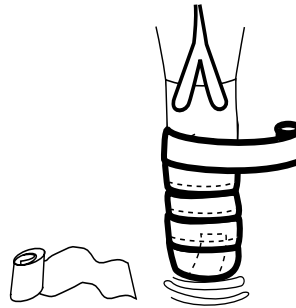

Fig. 2.15-d

5. Begin by overlapping plaster from just above the knee, down to the bottom of the leg to the back of the knee apply 3 layers. (Figures 2.15-e, f, g) *On the arm, begin just above the front of the elbow, down to the bottom of the arm and then up to above the elbow.*

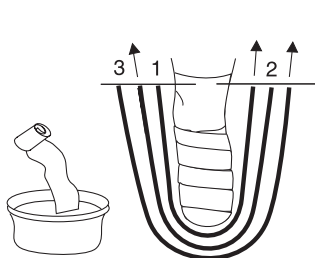

Fig. 2.15-e



Fig. 2.15-f



Fig. 2.15-g

6. Now starting approximately 7-8 cm above the knee or elbow, wrap in circles with enough tension to prevent wrinkles, but without pulling the wrap tight. (Figure 2.15-h)

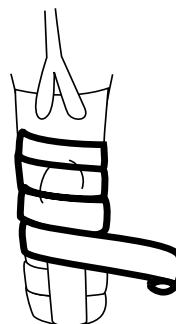

Fig. 2.15-h

7. Continue wrapping in circles until the entire limb is covered with at least 3 layers of casting. (Figures 2.15 -i&j) Smooth the bandages over the contour of the leg or arm.

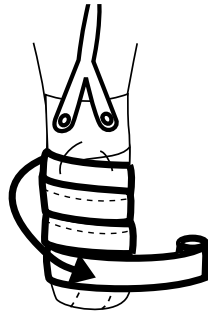

Fig. 2.15-i

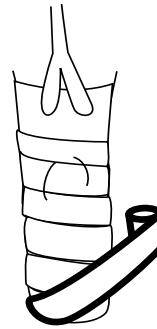

Fig. 2.15-j

8. Before the plaster dries, cut a hole out over the knee cap or elbow for pressure relief. (Figure 2.15-k)

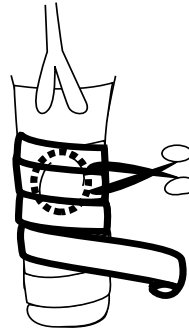

Fig. 2.15-k

9. Allow the cast to dry with the knee or arm in full extension by having the limb supported.

Things to remember for rigid dressings

- 1 The initial cast should be changed after 5 days of wearing, with inspection of the wound before a new cast is applied.
- 2 New casts should be replaced every 5-7 days.
- 3 If the cast begins to slide up and down because of limb shrinking, the cast should be removed and reapplied.
- 4 If the cast demonstrates bloody colored areas or if the person has a fever, remove the cast immediately and inspect the wound.
- 5 Discontinue use of the rigid dressing if skin sores develop.

2.4.3 Rigid Removable Dressing

A rigid removable dressing uses a single removable casted socket, in combination with layers of socks or cloth to make up for space that occurs as the limb shrinks. This technique is recommended for the person with a below knee amputation only. It should be removed only for a short time to see the wound or clean the limb.

Advantages of a rigid-removable dressing:

1. Protects the stump from trauma.
2. Allows inspection of the incision on a frequent basis.
3. Good way to decrease swelling.
4. Reduces stump pain.

Disadvantages/Contraindications of rigid removable dressings:

1. Must have casting materials and skilled person that are readily available.
2. Cannot be used when the incision line is not healing well.
3. Must be checked one time a week by the person who made the dressing

Materials to use for Rigid Removable Dressings (Figure 2.16):



Plaster of Paris



Belt or a strip of fabric



Gauze pads

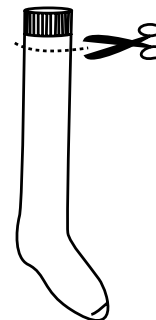

4 Socks, stockings or cloth
(one of them larger)

How to make the rigid removable dressing

1. Start by putting 2 socks over the limb. (Figure 2.17-a)

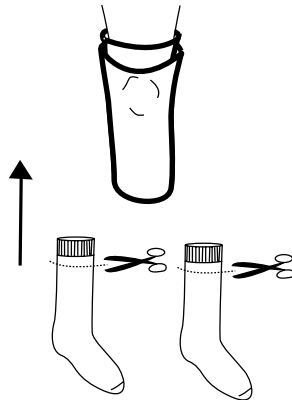

Fig. 2.17-a

2. Place the gauze pads on either side of the shin bone (tibia). Also place pads over the bony areas below the knee cap (medial plateau) and on the side of the leg (fibular head). (Figure 2.17-b)



Fig. 2.17-b

3. Wrap over the pads with cotton gauze wrap or available fabric making sure that the leg is symmetrical in width from the middle of the knee to the bottom of the leg. This will allow the cast to slide on and off the limb. Add extra layers to the bottom of the limb for added cushioning. (Figure 2.17-c)

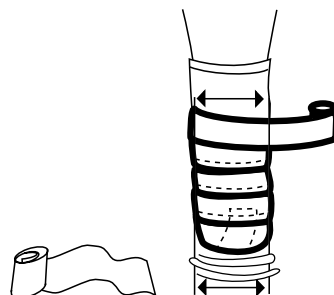

Fig. 2.17-c

Begin by overlapping plaster from just below the knee on the front of the leg, to approximately 15-cm above the center of the knee fold in the back. (Figure 2.17-d) Repeat the wrap to create three layers.

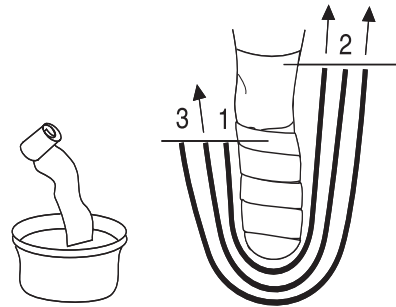

Fig. 2.17-d

5. Starting at the middle of the knee, use plaster to wrap in circles with enough tension to prevent wrinkles, but without pulling the wrap tight. (Figure 2.17-f) Note: Do not wrap any higher than below the knee fold in the back of the leg.

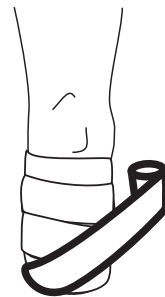

Fig. 2.17-e

6. Continue wrapping in circles until the entire limb is covered with at least 3 layers of plaster casting. (Figure 2.17- g)



Fig. 2.17-f

7. Allow the cast to dry with the knee in a straight position, and check that the socket can be removed and replaced easily. After completely drying, remove socket and sock.

8. Place a clean sock on the stump and replace socket.

9. Cover the socket with the larger sock to above the knee. Use Velcro, a belt or tie fabric above the knee to secure the sock in place. (Figure 2.17 h, i)

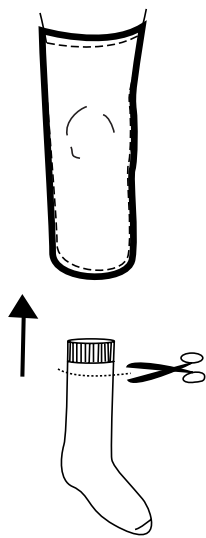

Fig. 2.17-h

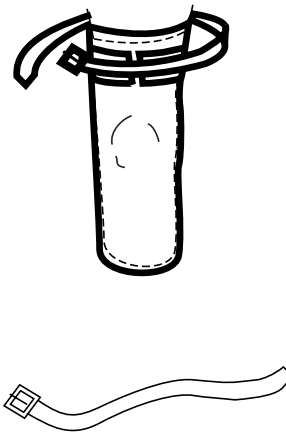

Fig. 2.17-i

Things to remember

- 1 As the limb shrinks, more socks should be added between the leg and cast to maintain good contact.
- 2 Weekly examinations should include checking the integrity of the wound and skin.
- 3 This dressing should be discontinued if significant skin sores develop, or if the person is not managing the proper sock thickness.

2.5 Skin Care

After amputation, the skin of the stump should receive daily care to prevent infection and to prepare the limb for using a prosthesis. If an amputation occurs as a complication of blood circulation diseases or diabetes, many of these principles are particularly important for both the amputated limb and the remaining limb.

Goals of skin care

1. Prevent infection and other skin irritations through proper hygiene and daily inspection.
2. Maintain skin mobility.
3. Decrease sensitivity of the skin on the amputated limb.

What to do

1. Skin hygiene and lubrication
2. Skin inspection
3. Skin mobilization
4. Skin desensitization

2.5.1 Stump Hygiene and Lubrication

Proper cleaning and lubrication techniques should be done daily to prevent open wound infections, skin irritations and dryness that can lead to new skin openings.

Cleaning

1. Wash limb with soap and warm water, and pat dry with towel. (Figure 2.18)
2. Allow two minutes of air-drying before replacing bandages or prosthesis.



Fig. 2.18

Lubrication

1. Every night rub lotion, cream or cocoa butter onto the limb.
(Figure 2.19)
2. Use small amounts so that the skin is not greasy or wet.
3. Do not rub into open wounds.
4. Wash stump socks every night.
5. Keep a clean supply of socks for two days to allow time for drying after the socks are washed.



Fig. 2.19

2.5.2 Skin Inspection

It is important to look at and to feel the condition of the skin of the stump to make sure no new open sores or pressure sores develop which could lead to infection. A pressure sore is a patch of skin (usually over a prominent bony area) that looks red or darkened longer than 30 minutes after pressure has been removed.

What to do:

1. Remove prosthesis or bandages and inspect the limb.
2. Use a mirror, or have someone else look at areas that are hard to see. (Figure 2.20)



Fig. 2.20

- 3 Next feel with the hands for any open areas on the stump.
- 4 Above knee amputations require special attention to inspecting the groin area and the buttocks area.
- 5 Below knee amputation require special attention to the shin bone the end of the stump and the back of the knee.

2.5.3 Skin Mobilization

These are ways to keep the skin of the stump mobile and pliable.

What to do:

1. Start on a bony area by placing fingers on one spot across the bone.
2. Press firmly, and move the deeper tissues moving across the bone for 30 seconds. (Figure 2.21)
3. Repeat to all bony areas of the stump.
4. After the surgical wound is completely healed, repeat this same technique to mobilize the surgical scar. The process is the same except the two fingers should be placed across the scar.



Fig. 2.21

2.5.4 Skin Desensitization

These are ways to decrease symptoms of overly sensitive skin on the stump.

What to do:

1. Rub with different fabrics on limb.
2. Tap with the fingers.
3. Massage.

Rub with different fabrics on limb

- Gather three or four different fabric textures that vary in roughness. Such as cotton rags, wool coat, burlap sack...etc.
- Begin by gently rubbing all the intact areas of the limb with the softest texture. (Figure 2.22). Be careful not to cause skin irritation or blistering.
- Once this is tolerated, repeat with the next roughest fabric texture.

**Fig. 2.22***Tap with the fingers*

- Using the pads of the fingertips or a smooth stick, gently tap the skin of the limb, avoiding the incision and other open areas.

Massage

- Begin with gentle massage near the remaining joint (hip, knee, elbow or shoulder).
- Gradually move the massage closer to the end of the stump.
- Gradually increase to a deep massage.

2.6 Exercise for the Person with an Amputation

A person with an amputation improves greatly if he is taught some of the basic goals of exercising, which are:

1. To improve or maintain the range of motion of all the limbs.
2. To Improve the strength of the limbs.
3. To Improve endurance for daily activities.

2.6.1 Range of Motion

After amputation the tissues of the remaining limb immediately begin to shorten and contract due to pain, immobility, muscle imbalances and loss of tissue elasticity as a result of surgery and skin grafts. This leads to a loss of range of motion in the joints known as a contracture. Contractures can make it difficult to wear a prosthesis, difficult to walk and can cause pain, Range of motion can be improved through proper positioning when sitting or lying down, stretching and performing active movement.

It is very important to avoid contractures because contractures cause many problems with prosthetic use and fitting.

The person with the lower extremity amputation often develops contractures with the hip and knee bent (Figure 2.23), and sometimes with the thigh turned out to the side (Figure 2.24).



Fig. 2.23



Fig. 2.24

The upper extremity may form a contracture with the elbow straight or bent depending on how the injury occurred. (Figure 2.25) For a person with an above elbow amputation, the shoulder may become fixed in a bent or an out to the side position.

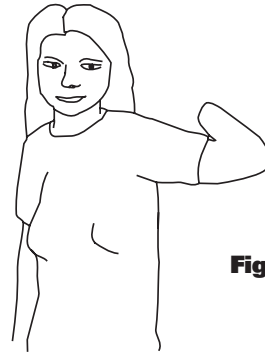
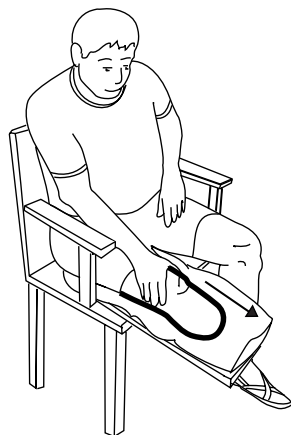

Fig. 2.25

2.6.2 Positioning

Positioning refers to how someone stands, sits or lies down. Proper positioning will reduce the formation of contractures. Some correct as well as some incorrect body positions are given below.

Correct Positions



(Figure 2.26a) Seated with the residual limb supported and knee straight.

Incorrect Positions

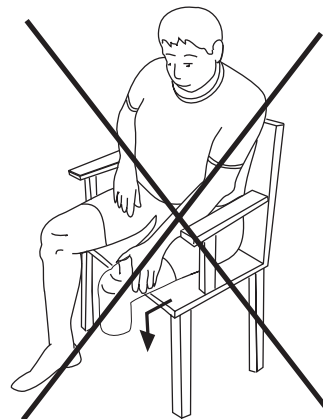

(Figure 2.26b) Seated with the residual limb unsupported and knee bent

Correct Position

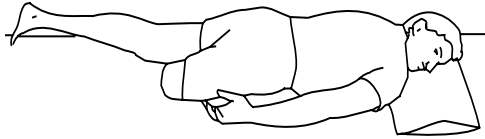

(Figure 2.27a) Lying on stomach with thigh flat on bed is the best resting position. Encourage as a sleeping position.

Incorrect Positions



(Figure 2.27b) Lying flat with the limb propped up on pillows.

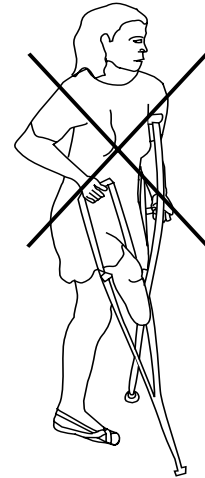

(Figure 2.28) Resting limb on crutch.

2.6.3 Stretching Techniques

Encourage the person or a caregiver to stretch the tight tissues of all limbs, especially the limb with the amputation. The most important stretches that people with amputations should perform are listed below.

Things to remember about stretching:

- 1 A "good stretch" means the body part is moved until a tolerable amount of tension occurs.
Mild discomfort is normal if it diminishes after the stretch is removed.
- 2 Each stretch should be held steady without bouncing for 30 seconds, and repeated 10 times.
- 3 Stretching should be performed at least 3 times a day or throughout the day, every day.

Stretching for lower extremity amputations

1. Knee to the chest, other leg flat on the mat (Figure 2.29).

- Pull one leg towards the chest while pressing the other leg flat against the bed or mat. Mild pulling is felt in both hips.
- Repeat stretch with the opposite leg pulled toward the chest, and the other leg pressing flat to the mat or bed.
- A caregiver can assist with this stretch by pushing one thigh to the chest while keeping the other leg flat on the mat.

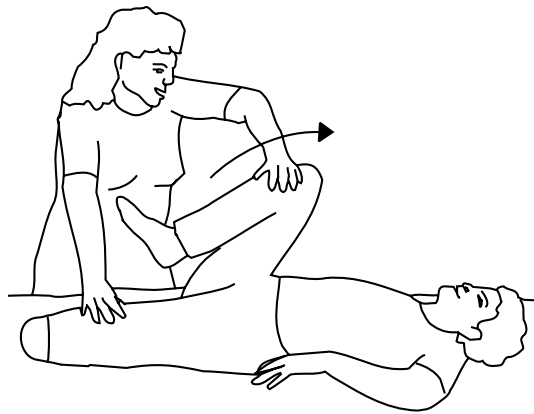

Fig. 2.29

2. Straightening the knee. (Figure 2.30)

- The person is seated with his amputated limb supported straight on a solid surface. The knee is then stretched as straight as possible by pushing down with the hands on the thigh just above the knee. Mild pulling should be felt at the back of the knee.

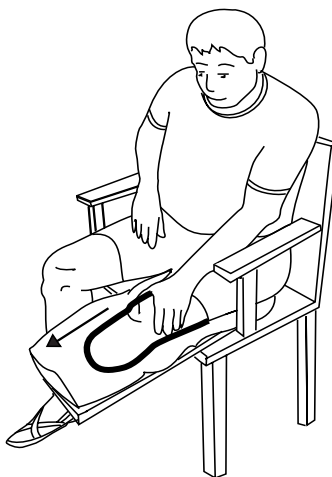

Fig. 2.30

Stretching for upper extremity amputations

1. Shoulder elevation stretch (Figure 2.31)

- Lift the limb upward using the other hand to push until a good stretch is felt just below the armpit.



Fig. 2.31

2. Shoulder cross-body stretch (Figure 2.32)

- Stretches the limb across the body using the other hand to pull it across. A good stretch is felt in the back of the shoulder.

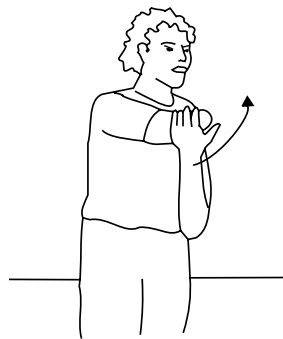

Fig. 2.32

3. Chest stretch (Figure 2.33)

- First, stabilize the front of the limb against an immovable surface (e.g. a wall or tree). Then twists the trunk /body away from the arm. A good stretch is felt in the chest area.

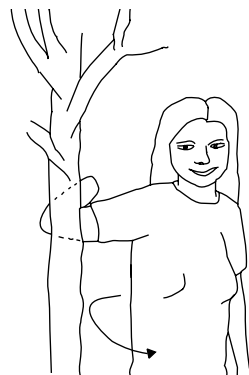

Fig. 2.33

4. *Straightening the elbow (Figure 2.34).*

- Sit with the elbow supported on a table. Use the other hand to push on the end of the limb, straightening the elbow. The stretch is felt in the front the arm.

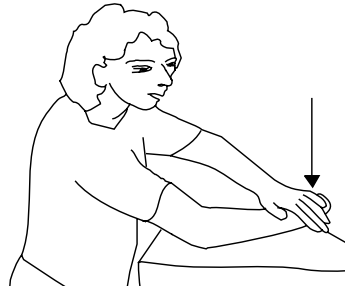

Fig. 2.34

5. *Bending the elbow (Figure 2.35)*

- Sit with the elbow supported on a table. Bend the elbow and use the opposite arm to push the elbow to bend A stretch is felt on the back of the elbow and arm.

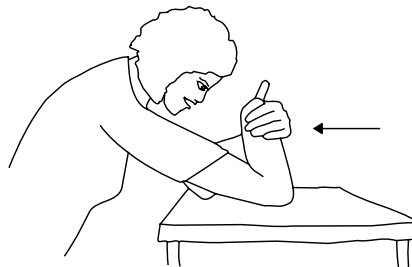

Fig. 2.35

2.6.4 Strengthening

Exercises to improve strength and active range of motion should begin soon after amputation, postoperative day 2 or 3, in order to maximize the person's function and mobility.

Things to remember about strengthening:

- All exercises should be done until the person experiences muscle fatigue. This usually occurs with 3 to 5 sets of 10 to 20 repetitions, with 10 seconds of rest between sets and 1-2 minutes between each different exercise.

- Make the exercise harder by adding resistance if a person can perform 3 sets of 15 repetitions against gravity. Resistance is increased by adding weight or force. The person should not be over exerting, if so reduce the resistance or number sets and repetitions.
- Resistance can begin with moving the limb against gravity (Figure 2.36-a), progressing to manual resistance by a caregiver (Figure 2.36-b), and finally to a safe method of weighted resistance. (Figure 2.36-c)

How to add resistance to exercises:

Against gravity: Lift the limb or body against gravity.
(figure 2.36a)

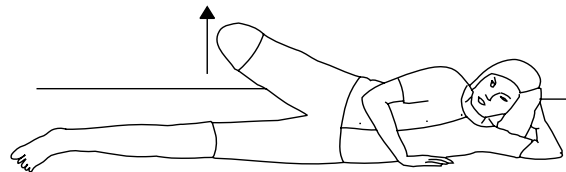

Fig. 2.36a

Manual resistance exercises: Have someone press against the limb as it is lifted. (figure 2.36b)

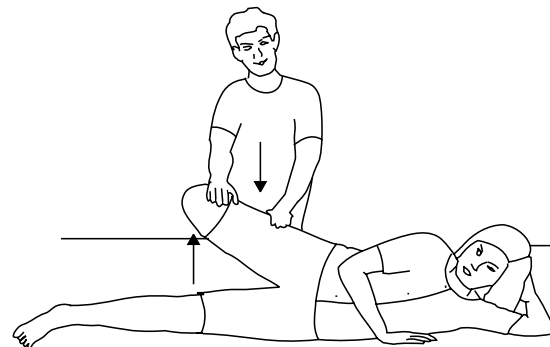

Fig. 2.36b

Use a weight for resistance, like a bag of sand, can goods or container of water attached to the limb and lift the limb with the added weight. (Figure 2.36c)

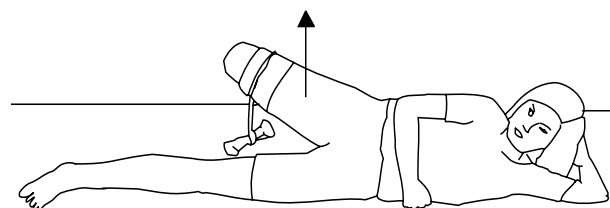

Fig. 2.36c

Exercises for people with lower extremity amputations:

People with lower extremity amputations should perform these strengthening exercises on a daily basis.

1. Sit ups (Figure 2.37)

Lie flat with the arms across the chest, and then lift the head and shoulders forward until the shoulder blades rise off the surface.

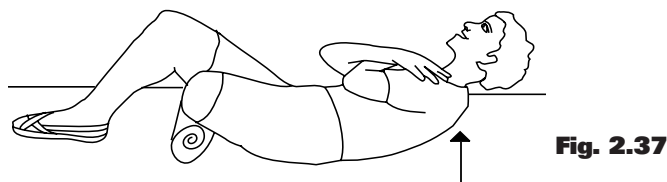

2. Hip flexion (Figure 2.38)

Lie flat on the surface, lift up the limb about 30 cm, and then return to the starting position. The exercise is repeated with the other leg.

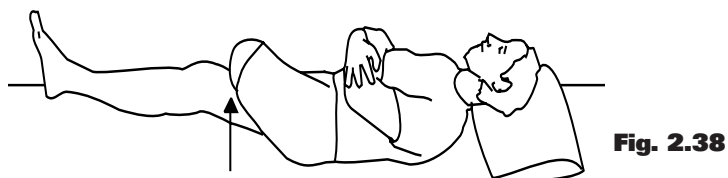

3. Legs apart (Figure 2.39)

Lie on your side, lift up the top leg in line with the body and then return to the starting position. The exercise is repeated with the other leg. May add a weight for added resistance.

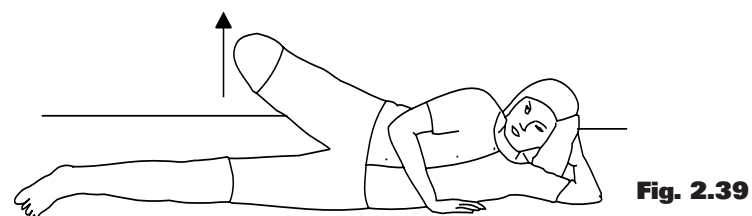

4. Hip extension with resistance (Figure 2.40)

Lie on the back with the stump lying on top of a rolled up towel or sheet. Bend the opposite limb. Then push down with the stump causing the buttocks to rise off of the support surface. Do not use the intact limb. Repeat the exercise with the other leg.

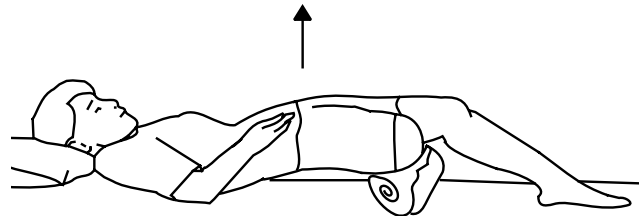

Fig. 2.40

5. Legs together (Figure 2.41)

Lie on one side with a rolled up towel between the legs. Then press down with the top leg into the towel roll, and hold for 10 seconds. Turn onto other side and repeated the exercise with the other leg.

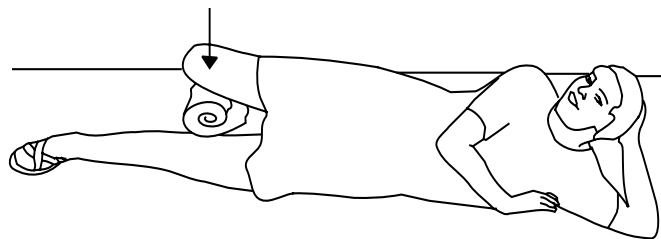

Fig. 2.41

6. Knee extension (Figure 2.42)

Sitting with the stump supported press the back of the knee down and hold it for 10 seconds.

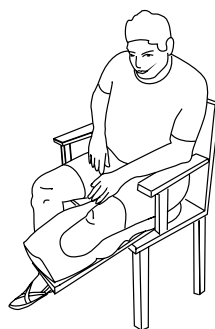

Fig. 2.42

7. Back extension (Figure 2.43)

Lie on the stomach with hands to the sides. Arch the back by lifting the torso and legs off of the support surface, and then return to the starting position.

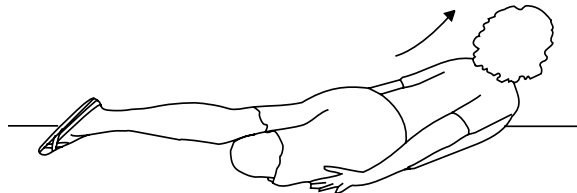

Fig. 2.43

Exercises for persons with upper extremity amputations

1. Shoulder flexion (Figure 2.44)

Raise the arms as high as possible in front of the body and then lower slowly.

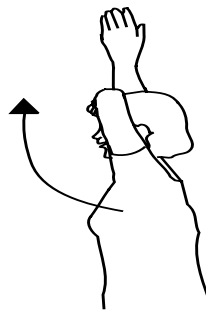

Fig. 2.44

2. Shoulder extension (Figure 2.45)

Stand with arms at the side, extend the arms backward as far as possible and then lower them slowly

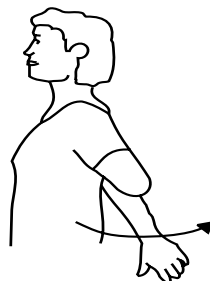

Fig. 2.45

3. Arm pushing forward (Figure 2.46)

Lie flat with arms elevated to 90 degrees. Then reach upward so the shoulder blades come up off the surface, and then lower slowly.

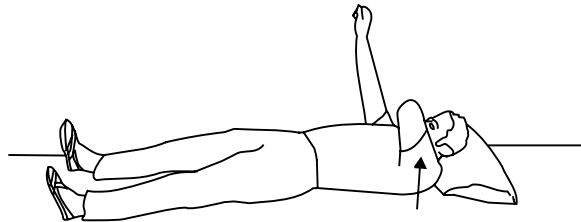

Fig. 2.46

4. Arms pulling back (Figure 2.47)

Lie flat on your stomach with the arms over the head, lift both arms off the supporting surface and then lower them slowly.

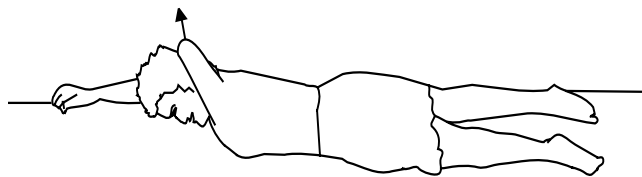

Fig. 2.47

5. Shoulder shrug (Figure 2.48)

Shrug or lift the shoulders towards the ears and then lower and press down the shoulders as much as possible.

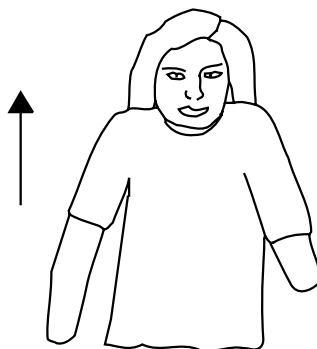

Fig. 2.48

6. Shoulder internal rotation (Figure 2.49)

Bring the arm behind the back and then across to the opposite side. Try to reach the opposite shoulder. Repeat exercise with the other arm.

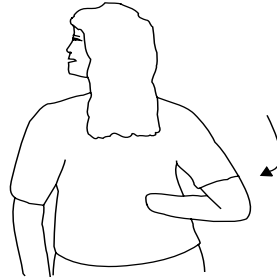

Fig. 2.49

7. Shoulder external rotation (Figure 2.50)

Lift the arm to the side and then try to reach behind the head and down the back. Repeat exercise with the other arm.

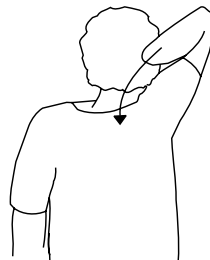

Fig. 2.50

2.6.5 Improving Endurance

Following an amputation, it is important for the person to remain as active as possible to prevent deconditioning. A person with a lower extremity amputation must improve his endurance level due to the increased energy requirements for using an artificial limb or using crutches. (See table on page 9) There are several methods of improving the endurance of a person with a recent amputation:

Walking programs

1. Can begin immediately for people with upper extremity amputations and after a person with a lower extremity amputation becomes proficient using crutches or walking frame.
2. Begin on relatively level terrain that is known to be free from obstacles.

3. People with upper extremity amputations can increase difficulty by walking on unlevel surfaces. Both groups can increase frequency and time for a greater challenge.
4. A typical program should last for 20 - 45 minutes, and be performed 5-7 days of the week.

Jogging programs

1. People with one upper extremity amputation can participate in a jogging program soon after amputation.
2. People with both upper extremities amputated must have good balance and be taught how to protect their head during a fall before a jogging program can begin.
3. Begin on relatively level surfaces that are known to be free from danger, progress to hilly surfaces.
4. Programs should last between 30-45 minutes and should be repeated at least 3 days per week.

Stationary bike programs

1. Can be performed by all people with amputations.
2. Programs can begin soon after amputation.
3. Programs can begin with 20 minutes and progress to 45 minutes, while performing at least 3 - 5 days per week.

To ride a stationary bicycle, the rear wheel is suspended off the ground upon the stabilized blocks, and should be secured into the upright position using rope. The front wheel can rest on the ground but must also be stabilized. The intact limb is secured to the pedal. (Figure 2.51)

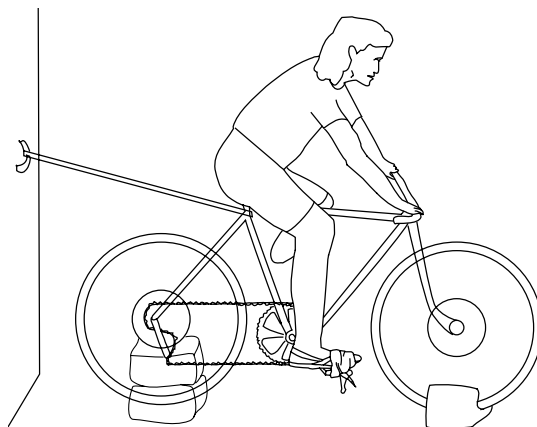

Fig. 2.51

The bike can be modified for upper extremity use by simply turning the bike over onto its seat and handlebars and stabilizing the frame. The person simply sits behind the front wheel and pedals with her arm(s). A more permanent modification is to remove the wheels and prop the frame of the bicycle up on blocks or a table. (Figure 2.52)

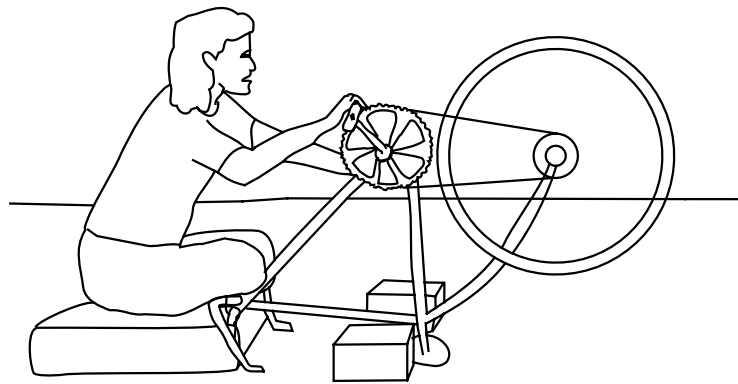

Fig. 2.52

3

Functional Activities Without a Prosthesis

3.1 Self Care for the Person with an Upper Limb Amputation

Taking care of oneself after an upper limb amputation is difficult and time consuming. New ways of doing familiar tasks should be explored. Sometimes a change of hand dominance or the use of adaptive devices to assist with activities will enable the person to do the activities. Another way to perform self care is to use the mouth or the feet. Whenever possible these activities should be done using a prosthesis. The self care ways discussed in this chapter are for before you learn to use a prosthesis, or if no prosthetic is available.

3.1.1 Bathing

Clean the entire body with the non amputated arm. (Figure 3.1)



Fig. 3.1

However, it is difficult to clean the non-amputated arm. If the amputation is below the level of the elbow, clean the non-amputated arm by draping the wash cloth over the stump.

If both limbs are amputated, sit in the shower and use the feet to assist with cleaning by draping the wash cloth over the foot. (Figure 3.2)



Fig. 3.2

Place a wash cloth on the back of a chair or hang it on a hook then clean the back and trunk rubbing up against it. (Figure 3.3)

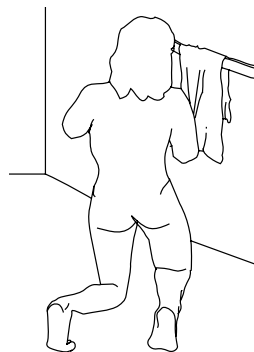

Fig. 3.3

All parts of the body can be dried in the same way that they were washed . A robe made of the same material as a towel can be used to passively dry the body.

3.1.2 Dressing

Using some assistive devices can make dressing easier for a person with a single arm amputation. Devices are a necessity for a person with a double arm amputation. For people who have a prosthesis, it should be donned before dressing and used to help with dressing.

When putting on a shirt or a dress it is best to use a pullover type without fasteners, buttons or zippers. Place the shirt in your lap or on a table. Stick both arms and your head into the shirt. Stand up and let the shirt or dress fall into place.

Shirt

If the shirt has buttons, it is possible to learn to use one hand to fasten the buttons however, a buttonhook can make it easier. (Figure 3.4)



To fabricate a button hook use a piece of wood about 12 cm long and 2 cm in diameter. Place a 6cm piece of wire in a loop inserting both ends into the wood. Shape the wire so that it is thinner at the top than the bottom.

To use the buttonhook, place it into the buttonhole, put the wire loop over the button and pull it through the hole. (Figure 3.5)

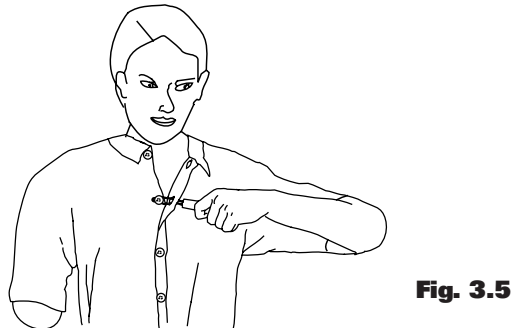

Pants:

To put on pants and undergarments, it will be easier if a loop is stitched into each side of the garment to help with pulling the pants up. (Figure 3.6).

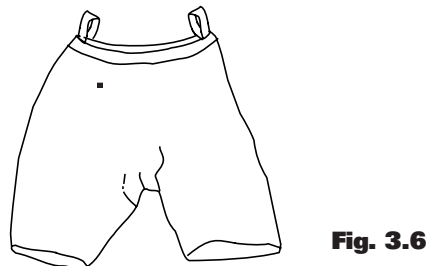

For the person with a double amputation, use a hook on a long stick that can be manipulated by the mouth or in a universal cuff (See Feeding Section 3.1.4). Use the hook on the loop to pull the pants up. (Figure 3.7)

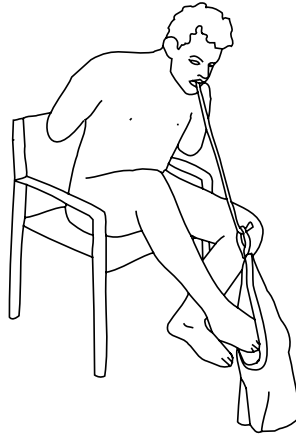

Fig. 3.7

Belts or straps:

When tying a strap or putting on a belt stabilize one end of the belt with the amputated arm and let the other arm tie or buckle the belt.

Shoes:

The best type of shoes to wear are those that can slip on or use Velcro to close since tying shoelaces is difficult with one hand.

3.1.3 Toileting

Toileting for person with the single upper limb amputation is easily adapted by performing it with one hand.

For the person with double upper limb amputation it is much more difficult. Place the toilet paper, cloth or leaf close to the floor so that it can be reached with the feet. Using the feet, manipulate the paper onto the heel of the foot and then squat over it to clean the perianal area. (Figure 3.8)

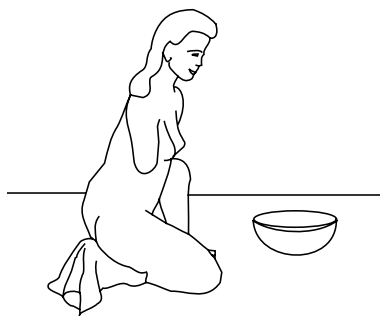

Fig. 3.8

Another method is to make a stand just below the level of the buttocks. The stand should have a flat narrow surface at the top. Place the toilet paper on the stand top using the feet, then stand and clean the perianal area by rubbing against the paper on the stand.

3.1.4 Feeding

Feeding for a person who has one upper limb amputated can be performed the same way as before the amputation. Some devices can make it easier.

Secure the bowl or plate to the table surface by weighting it or leaning it against something.

Use a knife with a round blade will make cutting food easier. (Figure 3.9).

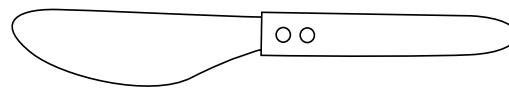

Fig. 3.9

Rock the knife up and down to cut instead of back and forth. (Figure 3.10)



Fig. 3.10

If the amputated limb is below the elbow, use a universal cuff to attach the utensils to the stump (Figure 3.11). *(To make a universal cuff, measure around the end of the limb. Use fabric to make a band around the limb that is easy to fasten. Sew a pocket on the cuff to hold utensils. Place the utensil or tool to be used into the pouch. Some times bending the utensil will make it easier to use. The cuff can be used for many purposes, not just feeding).*



Fig. 3.11

If both limbs are amputated above the elbow use the feet to eat. (Figure 3.12)



Fig. 3.12

To drink, use a straw in the cup. If the stumps are long enough, use them together to lift the cup to the mouth. (Figure 3.13)

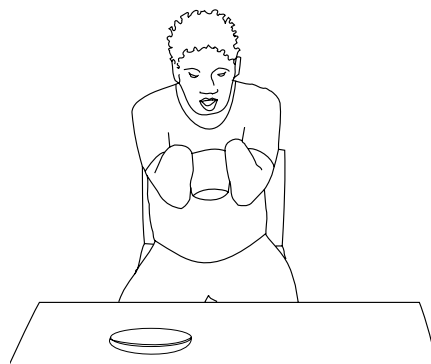

Fig. 3.13

3.1.5 Hygiene

Again, for the person with one arm amputated, most activities can be done with one hand. For the person with a double arm amputation washing the face, combing the hair, brushing the teeth, shaving or putting on makeup can be done with a long handled holder.

Place the holder in between the knees, attach the brush, razor or lipstick in the holder, and perform the above tasks by moving both the head and knees. (Figure 3.14)

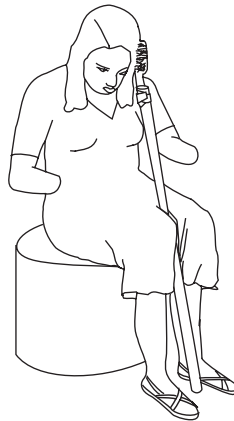

Fig. 3.14

Some other options are to do it with the feet or to have a stand on a table that will hold the brush, washcloth etc. and just move the head.

3.2 Transfers and Mobility for the Person with a Lower Limb Amputation

3.2.1 Unilateral Amputation

An individual who has a leg amputation must be taught mobility using the intact limb only. The following overview covers the most basic mobility skills that must be learned.

Transfers

An important transfer that all people with leg amputations must learn is a transfer to and from the floor. Move to the edge of the seat, and have both arms set on the seat.

Slowly lower the backside to the ground using the arms, with the intact limb as a guide. (Figure 3.14a, 3.14b) Get up from the floor to the chair by placing both arms on the seated surface with the intact leg bent, and then push down with the arms and push backwards with leg to lifting up onto the seat.

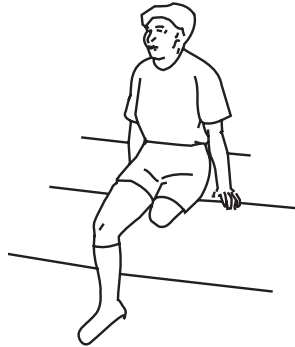

Fig. 3.14a

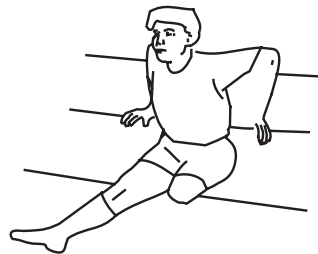

Fig. 3.14b

Another method to get down to the floor is to move to the edge of the chair, turn the upper body around and place the hands on the seat of the chair. (Figure 3.15a) Facing the seat lower to a kneeling position. (Figure 3.15b)

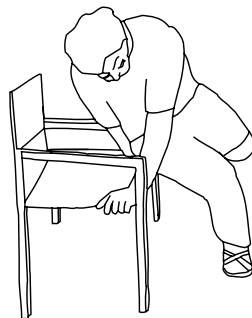

Fig. 3.15a

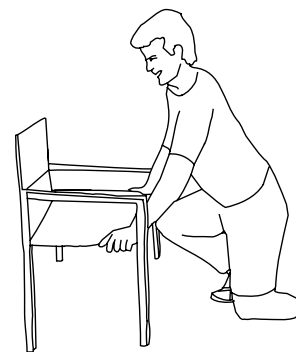

Fig. 3.15b

Get up by repeating the process in the opposite direction. Kneel on the legs and place the arms on a sturdy surface such as a seat. Press down with the arms and push up onto the intact leg. Turn and sit onto the chair.

Walking

An individual with a single leg amputation should be able to hop with a support device. Possible devices include one or two crutches, a walking frame, and possibly two sturdy canes or a large stick.

Crutches

Crutches can be used for walking. There are two types that are used: those that go under the armpit (axillary crutches) and those that go around the arm (forearm crutches).

To use axillary crutches adjust the height to have at least three finger widths between a person's armpit and the top of the crutch to prevent leaning on the crutch tops and avoid nerve and blood vessel damage. The hand grip should be placed so there is a 15 degree bend in the elbow (Figure 3.17)

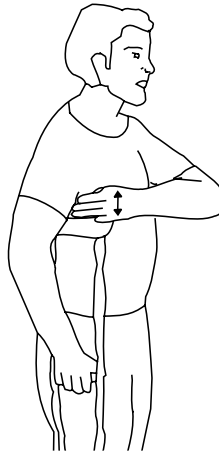

Fig. 3.17

To use forearm crutches, place the height so that the elbow is bent about 15 degrees (Figure 3.18).



Fig. 3.18

With two crutches kept 15 to 20 cm to the side of the body, the person should move them 25 to 30 cm forward. (Figure 3.19-a) The person next squeezes the crutches against the chest while pushing down on the handles, and moves the non-amputated leg forward to the level of the crutches. (Figure 3.19-b)

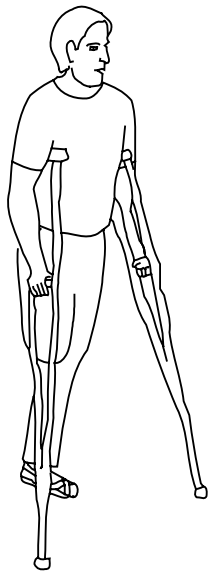

Fig. 3.19a



Fig. 3.19b

If only a single crutch is available, place the crutch at least three fingers breadth below the armpit on the intact leg side. Move the crutch forward about 15 - 25 cm, push down on the handle and hop with the intact leg.

If no crutch is available, use a large, sturdy wooden branch (at least 2-meters long) for hopping short distances. Move the branch about 20-cm forward (Figure 3.20a), and with both arms on the branch push down and hop the other leg forward. (Figure 3.20b)

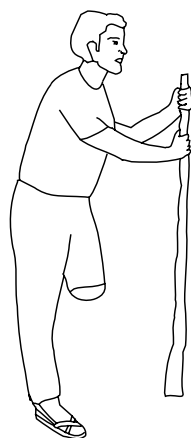

Fig. 3.20a



Fig. 3.20b

Walking frame

When a walking frame is available, adjust the height so that the elbow is bent about 15 degrees. Move it 20 to 25 cm forward (Figure 3.21a), then push down with both arms and hop the other leg into the middle of the frame. (Figure 3.21b) The walking frame is recommended for older and weaker people because it is more supportive and stable.



Fig. 3.21a

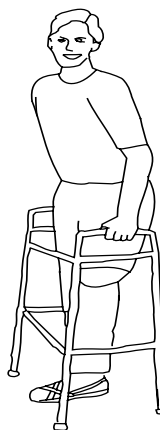

Fig. 3.21b

Going up and down stairs

Going up or down steps can be safely done on a person's back side or actually hopping with the other leg using the help of a rail and/or a cane or crutch.

Going Up and Down Steps on the Buttocks

Face the step and bend forward reaching hand onto the step for support. (Figure 3.22a) Leaning onto the step turn your body and lower yourself to a sitting position on the step. If a railing or cane is available, reach one hand for the step and hold onto the railing with your other hand. (Figure 3.22b)

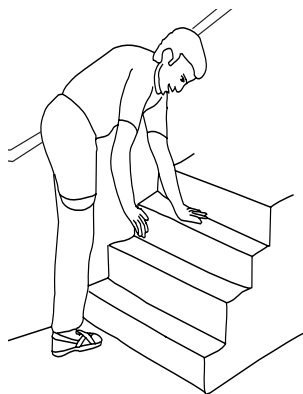

Fig. 3.22a

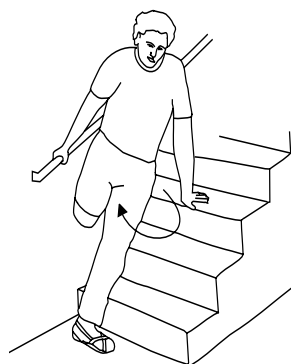

Fig. 3.22b

To go up the steps, push with both hands on the step above and with foot on the ground and lift the trunk up to the next step. Once at the top of the steps, perform the floor to seat transfer described on page 63.

To come down the steps, place both hands on the step you are sitting on and extend the intact leg at least two steps lower. In one motion push with the arms and lower the backside down one step (Note: The intact leg should guide the descent.) Repeat this process down the steps. Once the person is two steps from the ground pull up using the railing or push up using the crutch. You will need someone to assist you by carrying the crutch or walking frame up and down the steps for you.

Hopping up a step or curb

An individual who is able to lift his body weight easily may be able to hop up and down a step or curb using canes or crutches.

Going up, the person faces the step with both hands on the crutches. Note: If a rail is present it is best to use it, and place the cane or crutch in the other hand. Lean forward and push down with the arms enough to hop the intact leg forward up the step and follow with the crutches. (Figure 3.23)

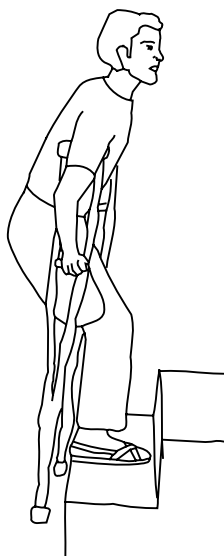

Fig. 3.23

Coming down a step, start at the edge of the surface and place the crutches on the ground or one step below. Then lean slightly forward and push down with both hands enough to safely lower the intact leg down to the ground or next step.

3.2.2 Bilateral Amputation

Transfers

Front on and off transfer

The most basic transfer for a person with bilateral leg amputations is to go from one seating surface to another. The front on and back off transfer is the safest method for getting in and out of bed. However, be careful to avoid pulling on the skin and the wound. Never place the end of the stumps directly down on the bed.

For this method, face the bed. Using both arms, push down on the chair arms or seat enough to move the body forward onto the bed. (Figure 3.24) To return back to a wheelchair or wheeled cart, face away from the chair, and again push with both arms down on the seat enough to move the backside onto the chair.

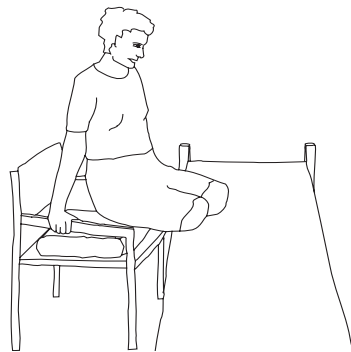

Fig. 3.24

Side on and off transfer

Another transfer a person with bilateral leg amputations can safely do is the side on and off, which is very effective for moving onto surfaces of different heights. If using a wheeled cart or wheelchair, place it to the side of the seat the person is moving to. Remove any armrest or bar, if possible. Then place the closest leg and arm on the seat and push down enough to move the rest of the body onto the seat. (Figure 3.25)

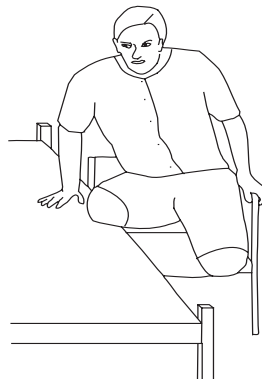

Fig. 3.25

Floor transfer to and from a seated surface

To go from a chair to the floor, turn over onto the stomach (Figure 3.26a), and slide the legs slowly off of the chair onto the ground. (Figure 3.26b) Then lower the backside onto the ground using the arms while the legs are stabilizing. *Note: To help with the transfer, a person can use a stool or wood box that is one-half the distance from the floor.*

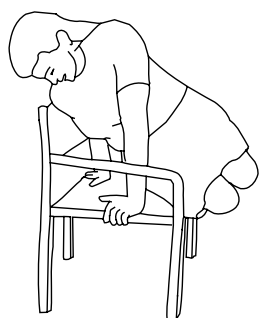

Fig. 3.26a

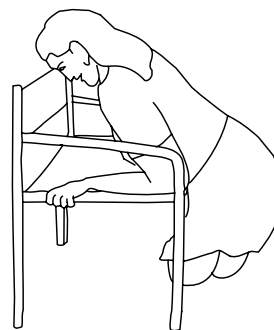

Fig. 3.26b

Getting back up from the ground, use both arms to elevate the backside onto the chair which is placed behind you. (Figure 3.27), or use a stool to reduce the distance from the floor to the chair.



Fig. 3.27

Mobility

For most people with bilateral amputations the only safe option for mobility is with a wheelchair or wheeled cart (Figures 3.28a, b). Mobility is done using the hands to move the wheels.

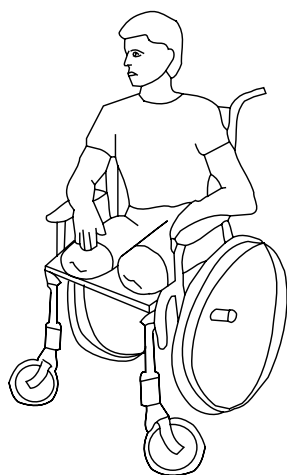

Fig. 3.28a

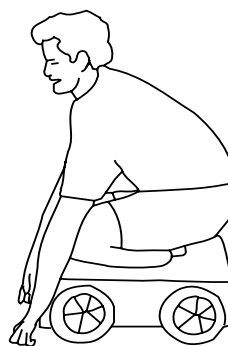

Fig. 3.28b

Once a doctor states the incisions are well healed, an individual may be able to tolerate walking on the knees (bilateral below knee amputations) with padded protectors. (Figure 3.29)

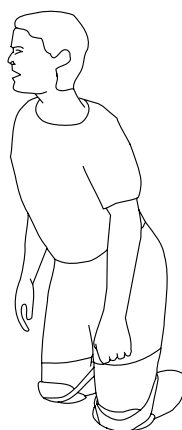

Fig. 3.29

Elevations

To get up and down a step without the use of a wheelchair or wheeled cart, first get to the ground using a floor transfer (See Floor transfer on Page 69). An alternative is to transfer directly to the step from the chair using a smooth board, (Figure 3.30)

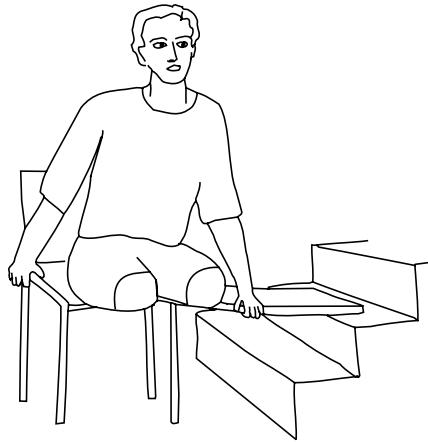

Fig. 3.30

Once you are on the ground, go up the step by placing your arms on the step above you and use your arms to push yourself up to the next step. To go down the steps, place your arms on the step on which you are sitting and lift and lower yourself to the step below, as shown on page 69.

3.2.3 Precaution for Caregivers

When caregivers must help lift someone, it is important that they protect their backs. This is how to safely lift a person.

Stand directly in front of the person who is being lifted. Bend the hips and knees and keep the back straight or with mild inward curve in lower back. (Figure 3.31a)

Hold the person around the waist, keeping her close to your body. A belt around the waist will help in managing the lift.

Lift up the person by straightening your knees and hips and pulling up with your arms. (Figure 3.31b)

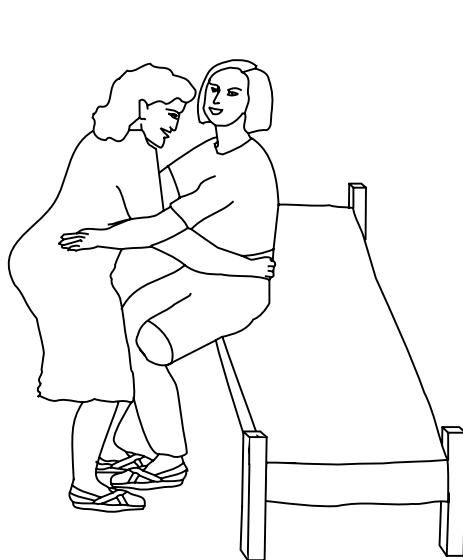

Fig. 3.31a

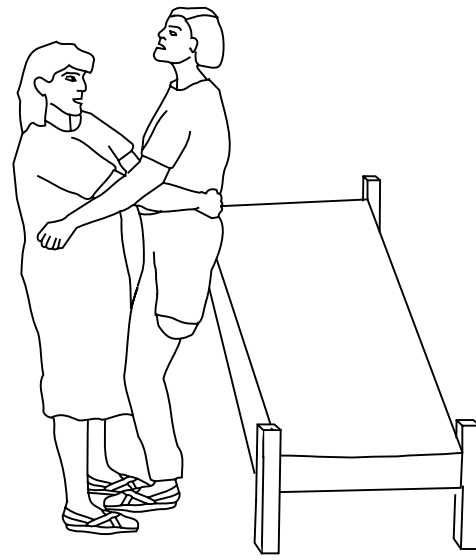

Fig. 3.31b

4

Information About the Prosthesis

A prosthesis can improve the results of the rehabilitation of the person with a limb amputation. If given the opportunity, most persons with an amputation will be able to use an artificial limb well. However, some people with very short stumps, very weak muscles, wounds that will not heal, excessive scars from burn or injuries, very sensitive stumps, or multiple other injuries may choose not to use a prosthesis.

Essential information for the prosthetic user:

Educating the person with an amputation about how the prosthesis works, what parts it has, and how it is made, will allow her to better communicate with the clinicians her needs and concerns. Explanations of how the prosthesis fits, where weight is borne, where and why discomfort may occur, and how adjustments can be made, reduces nervousness and helps the prosthetic user know when to return for adjustments. It is useful to remind the person with a lower extremity amputation that her weight must be supported by some pressure tolerant portion of the stump, or walking would be impossible. Pressure is to be expected and this may be uncomfortable at first but should not be painful.

With experience and the instructions of the treatment team, the person with an amputation learns the appropriate fit of the prosthesis and the way to adjust the fit with prosthetic socks. The following section reviews these concepts.

4.1 Parts of the Below Knee Prosthesis

The below knee amputation is one of the most common types of amputation. Most people who are given a below knee prosthesis are often able to walk fairly easily and are able to continue their previous activities.

Parts of the Below Knee Prosthesis (Figure 4.1)

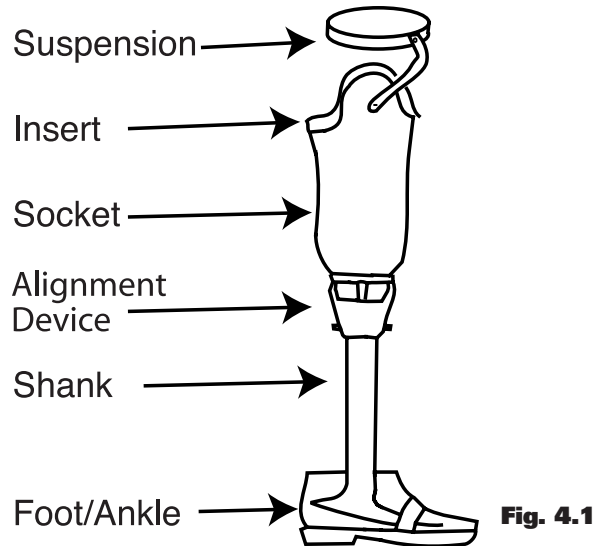

4.1.1 Socket:

The socket is the section of the prosthesis that will be in contact with the skin. It is important that the socket fits correctly or it will cause the limb to be uncomfortable, painful or cause skin irritation. The below knee prosthesis is made so that there is pressure placed over areas of the leg that are pressure tolerant, while pressure sensitive areas will have less pressure. Any body part where there is muscle or soft tissue is considered **pressure tolerant**. (Figure 4.2)

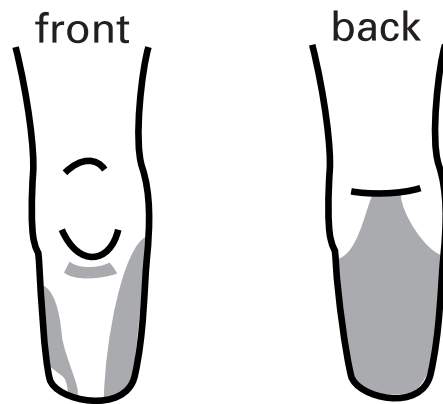

The most tolerant area is between the knee cap and the top of the shin bone. This is called the patellar tendon.

The parts of the limb that are bony are considered **non-pressure tolerant**. (Figure 4.3) The socket should preferably be total contact but the socket is made so there is less pressure over these areas.

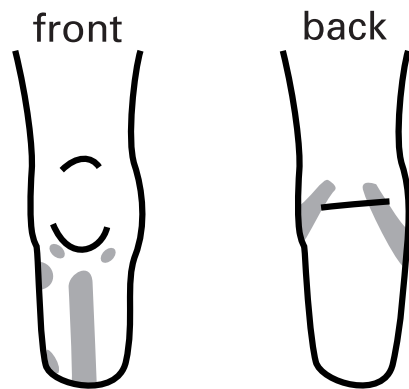

Fig. 4.3

The socket may not fit correctly for many reasons. It may have been made incorrectly and need adjustment by the person who made it. Changes in the person's size due to swelling or shrinking of the leg can also cause the socket to fit poorly. Loss or gain of body weight will also effect the fit. It is very important that the person with an amputation know how to adjust the socks that are worn with the leg to keep a good fit. *See the Section 5.4.1 on managing prosthetic socks.*

Things to look for to make sure the socket is fitting correctly:

- The socket should be tight but still comfortable.
- The leg should not slide up and down in the socket.
- The socket should have contact with the limb everywhere but it should not have too much pressure on the bottom.
- Added pressure should be felt between the knee cap and the top of the shin bone. (The patellar tendon).
- The socket should not cause a wound or ulcer.

4.1.2 Insert:

Some sockets will have a liner that is made of a softer material than the socket. It is often the same shape as the socket and can be made of foam or silicone materials. The purpose of the insert is to give the stump some added protection. (Figure 4.4)

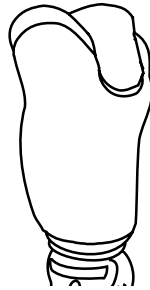

Fig. 4.4

4.1.3 Suspension:

The suspension is the part of the prosthesis that holds the artificial limb on to the stump. There are many types of suspensions that can be used. Typically, straps or belts made out of leather, cloth or rubber are used. The prosthesis needs to be kept on tightly to prevent up and down sliding that can produce friction and cause skin irritation, or if not corrected, even sores .

4.1.4 Shank:

This is the part of the artificial limb that connects the socket and the foot. It is made of durable materials such as rust proof metal, wood, hardfoam or plastic.

4.1.5 Foot/Ankle

This part of the artificial limb is the one that contacts the ground. (Figure 4.5) There are many different types of feet. The person with a lower limb amputation should be educated to the fact that the foot is made to fit only one heel height and that changing footwear or removing the shoe will alter the way the prosthesis works and could result in pain or skin sores . (See Section 4.3.5 on page 85)

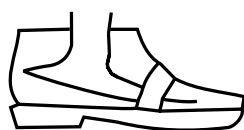

Fig. 4.5

4.1.6 Cosmetic Cover:

Many times the prosthesis will have a foam cover over the shank that is shaped to look like the other limb.

4.2 Parts of the Above Knee Prosthesis

The above knee amputation is also very common. However the loss of the anatomical knee does make it more difficult to walk and uses more energy than when the amputation is below the knee. Despite this, many people are able to walk very well with an above knee prosthesis

These are the parts of the above knee prosthesis or artificial limb
Figure 4.6:

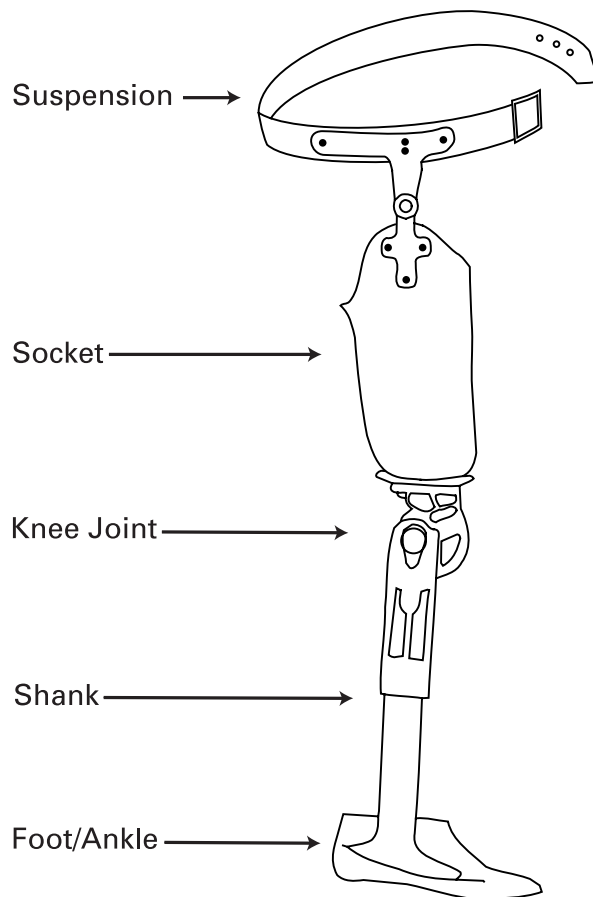

Fig. 4.6

4.2.1 Socket:

Just like the below knee prosthesis, the socket is the part of the prosthesis that will be in contact with the skin. Many of the same problems with socket fit occur with an above knee prosthesis as with a below knee prosthesis. (Please see page 75) People with above the knee amputation must also learn how to adjust the socks that are worn with the leg to keep a good fit. *See the section 5.4.2 on managing prosthetic socks.*

Unlike the below knee prosthesis, where one socket design is used for all sockets, the above knee prosthesis may have one of two socket designs that are used. The two most common types are the quadrilateral socket and the ischial ramal containment (IRC) socket.

Quadrilateral Socket: Principles (Figure 4.7)

- 1 Total contact
- 2 Narrow front to back
- 3 Weight is borne on the ischium or buttocks bone

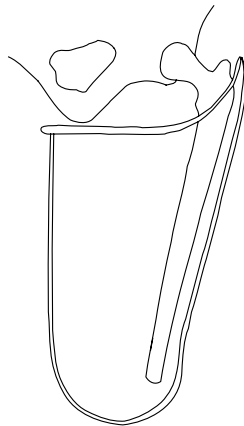

Fig. 4.7

Things to check for a good fit:

- 1 The end of the stump should touch the bottom of the socket but not have too much pressure or be uncomfortable.
- 2 The buttocks bone should sit on the top back of the socket.
- 3 There should be a relief for the adductor tendon. (The muscle attachment in the upper inner leg near the groin)
- 4 The socket should feel snug.
- 5 There should be no groin pain.

Ischial Ramal Containment Socket Principles: (Figure 4.8)

- 1 Total Contact
- 2 Narrow side to side
- 3 The ischium or buttocks bone should be inside the socket

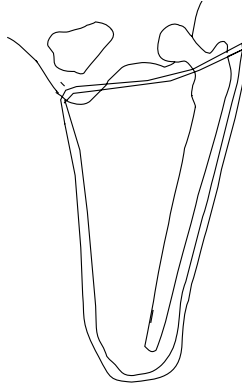

Fig. 4.8

Things to check for a good fit:

- 1 The end of the stump should touch the bottom of the socket but not have too much pressure or be uncomfortable.
- 2 The socket should enclose the inner thigh tissue.
- 3 The buttocks bone sits within the back wall of the socket.
- 4 There should be no groin pain.

4.2.2 Suspension:

See Page 76 for explanation. The most common types of suspensions for the above knee prosthesis are:

Silesian band (Figure 4.9): Made of cloth or leather, this belt wraps around the waist below the pelvic bone and above the hip. The belt attaches to the lateral wall of the prosthesis and buckles into the front wall of the prosthesis.

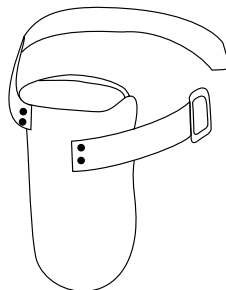

Fig. 4.9

Pelvic band with external hip joint(Figure 4.10):Used when the person with an amputation has a short limb or weak hip musculature with decreased ability to control hip movement, particularly hip abduction or movement of the limb out to the side.

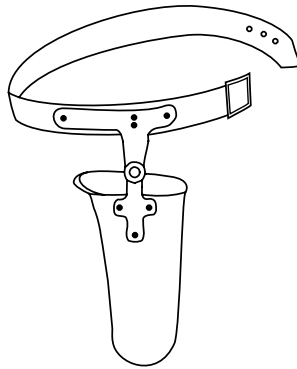

Fig. 4.10

Suction suspension: (Figure 4.11) This suspension does not need a belt but requires the socket to be in direct close contact with the skin. Prosthetic socks are not worn with this type of socket. There is an air valve at the bottom of the socket to allow the person with amputation to push the air out of the socket. This creates negative pressure or suction inside the socket. This suspension is frequently used in younger more active persons with amputations. Putting on this type of socket requires strength, balance and coordination. The advantages of this system is the increased freedom of motion allowed while promoting the use of the remaining thigh musculature and improving comfort if correctly fitted. The person with an amputation who is using a suction suspension will need to keep a stable body weight without changes of more than 5 kg.

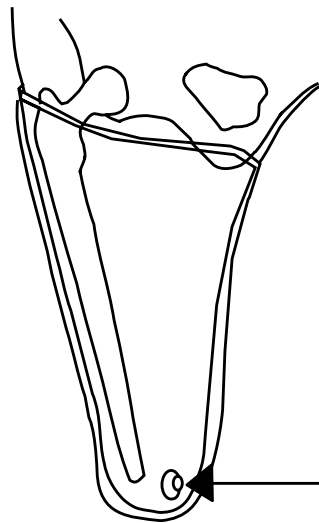

Fig. 4.11

4.2.3 Knee Joint:

The knee joint is very important for both safety and mobility. For the highest degree of safety some people will choose a limb whose knee does not bend. Others may have a moving knee joint. The stability of the knee joint is related to many things. The type of knee joint, the alignment of the prosthesis and the strength of the person controlling the limb all effect how well a person can control the prosthetic knee. (Figure 4.12)



Fig. 4.12

4.2.4 Shank:

This is the part of the limb that connects the knee and the foot. It is made of durable materials such as rust proof metal, wood, hard foam or plastic. (Figure 4.13)

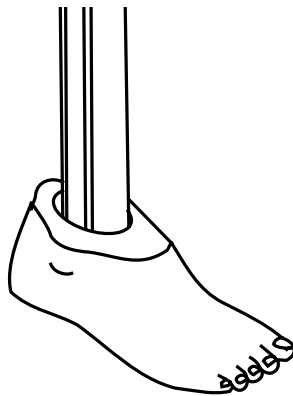

Fig. 4.13

4.2.5 Foot/Ankle:

The foot and ankle are the same for either a below the knee or above the knee prosthesis.

4.2.6 Cosmetic Cover:

Once the prosthesis is made it is covered with a soft material that is shaped to match the other limb. This is called the cosmetic cover. It has no functional purpose except to make the limb look more like a real limb. Some people may choose not to have the cover applied.

4.3 How a Lower Limb Prosthesis is Made:

The process of making an artificial limb includes all of the following:

- Measuring the limb
- Making a plaster mold
- Making the socket
- Attaching the shank, suspension and foot
- Aligning the prosthesis

4.3.1 Measuring the Limb

The first step in making a prosthesis is to take measurements of the stump and the leg length of the opposite limb. The prosthetist will use measuring tapes and a caliper to get the exact measurements that are needed.

4.3.2 Making the Plaster Mold:

After the leg measurements are taken, a sock is placed over the leg and the pressure sensitive areas (Figure 4.14) are marked with a pencil. An impression of the limb is taken by using a plaster of Paris wrap.

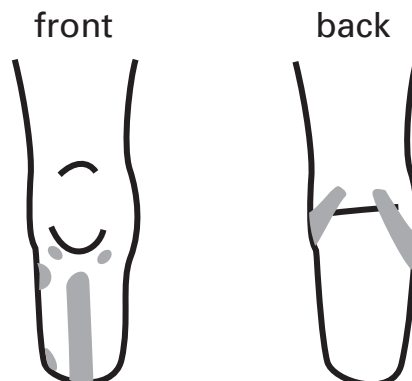

Fig. 4.14

The hardened cast is then removed from the stump. This is called the negative mold. The negative mold is filled with plaster and allowed to harden. Then the negative mold is removed from the outside. The plaster model that is left is an exact copy of the stump. This is called a positive mold.

The prosthetist will then make changes to the shape of the mold to make the prosthesis comfortable. He will build up areas (add plaster) where bones are prominent or tissues do not tolerate pressure and take away plaster from the areas where the limb can tolerate pressure.

4.3.3 Making the socket

Once the positive mold is ready the prosthetist will drape the plastic or laminate material of the socket over it and mold it to the correct shape.

4.3.4 Attaching the Suspension, Shank and Foot

Once the socket is made, the prosthetist will attach the suspension system, the knee joint in an above knee amputation, the shank, the ankle and the foot. (Figure 4.15):

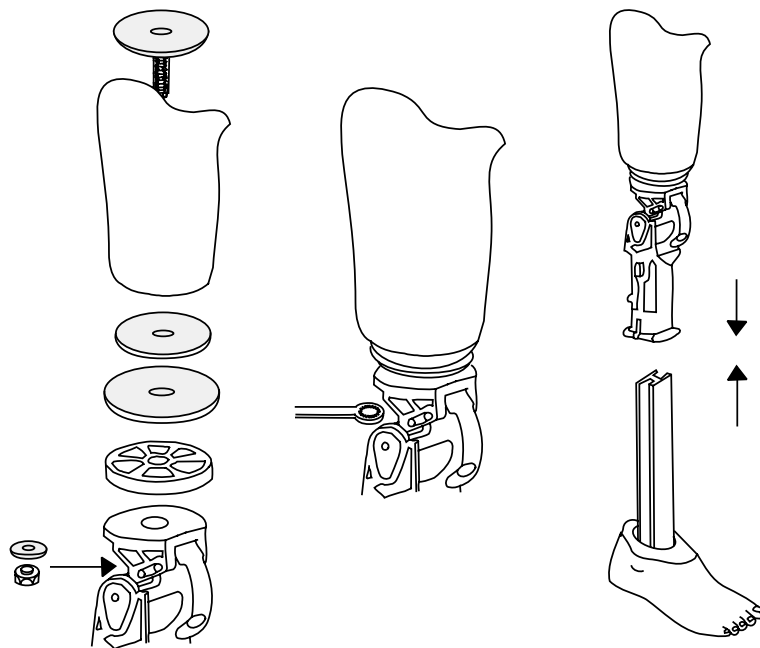

Fig. 4.15

4.3.5 Aligning the Prosthesis:

Alignment of the prosthesis is the last part of making the artificial limb. Alignment means adjusting the relationship between all the parts of the prosthesis. For example: the position of the foot in relation to the shank and the position of the socket to the shank. Figure 4.16 shows how the angle of the socket can be changed by attaching it differently.

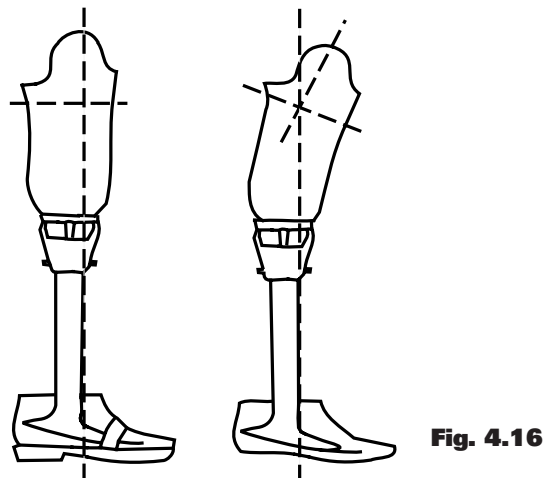

Fig. 4.16

An initial alignment of the prosthesis will be made by the prosthetist but changes will probably be needed during gait training. The person with the amputation may even need to return to the prosthetic services several times after the prosthesis has been finalized for fine tuning the alignment. The prosthetist should be the only one to change the alignment.

Changes in the alignment of the artificial leg can have an impact on the comfort of the prosthesis because they can change where the pressure is applied in the socket.

Factors that affect the alignment of the prosthesis include the shoe and the height of the heel. If the heel height is changed it can tip the prosthesis forward or backward. The prosthetist will set the prosthesis to the heel height of the shoe (Figure 4.17).

If no shoe is to be used he may accommodate for this as well. Increasing the heel height after the leg is fabricated will tip the leg forward forcing the knee to bend. (Figure 4.18) Decreasing the heel height will tip the leg backward and may give increased pressure on the front of the knee. (Figure 4.19)

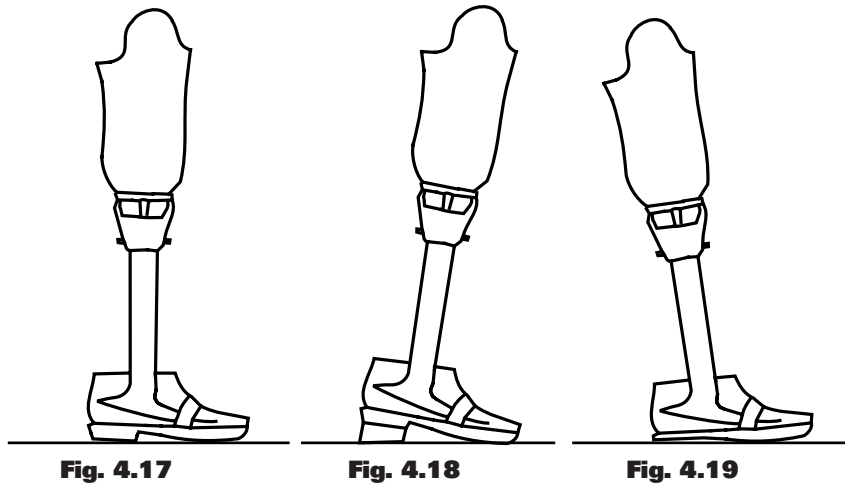

4.4 The Upper Limb Prosthesis

Upper Limb amputations are much less common than lower limb amputations. In order for a person who has had an arm amputation to have the best chance to use a prosthesis well, it should be made as soon as possible.

Parts of an Upper limb Prosthesis (above elbow): (Figure 4.20)

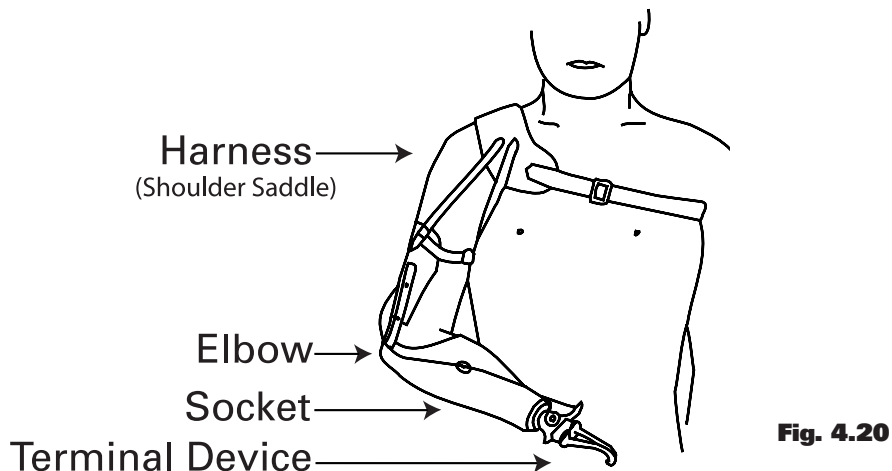

4.4.1 Socket

Just like the lower limb prosthesis, the socket of the upper limb prosthesis is very important because it comes in contact with the skin. It must be comfortable or the person will not be able to use the prosthesis. Unlike the lower limb, the arm prosthesis will not have to bear the full body weight. The socket is made with pressure relief over the bony areas at the end of the limb, the elbow and the shoulder.

4.4.2 Harness (Figure 4.21)

Most upper limb prosthesis will be held on to the body using straps or a harness. The straps are made out of leather, cloth or canvas. The straps extend in a figure of "eight" shape behind the back and under the opposite arm holding the prosthesis in place. When using a mechanical device the harness is also used to open the hand/hook or to move the elbow.

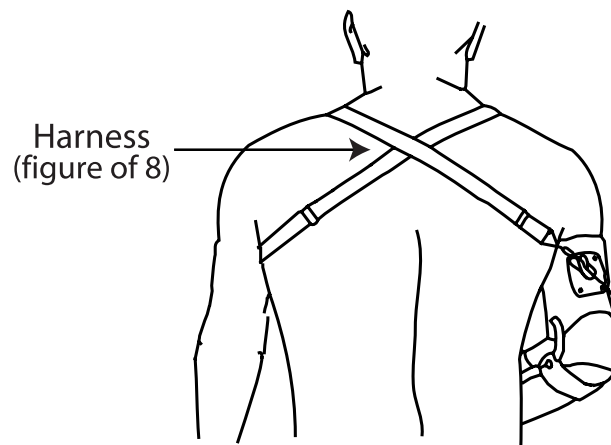

Fig. 4.21

4.3.3 Elbow

Mechanical elbows are simple hinges that allow movement of the arm up and down, extend the arm in space and allow the hand or terminal device to bring objects to the mouth or body. Elbows can be bent using a cable connected to a harness or by lifting them with the other arm. A locking mechanism can be used to keep the elbow in a certain position while the person uses the hand.

4.4.4 Terminal Device

The upper limb prosthesis can have different types of terminal devices.

Hands (Figure 4.22)

Hooks (Figure 4.23)

Manipulators (Figure 4.24)

Hands can be non functional (a stuffed glove), mechanical (body power) or electric. (Figure 4.22) Hands have a better appearance but may be heavier and have less strength than a hook.

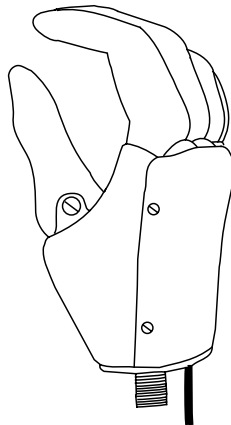

Fig. 4.22

Hooks allow more rugged use and allow the person to see objects that are being handled, this will make manipulation of objects easier because you must rely on vision instead of feeling to manipulate objects. (Figure4.23)

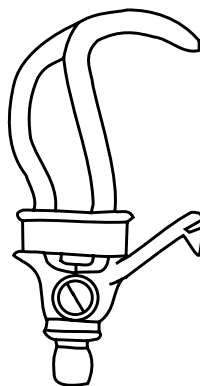

Fig. 4.23

Manipulators are non-grasping terminal devices that can be used to push or pull objects.(Figure 4.24) These devices are simple to use and fabricate and can allow great degree of independence. Manipulators can be made of metal or wood, have different lengths, angles and shape. The tips should be covered with a rubber material to improve grip.

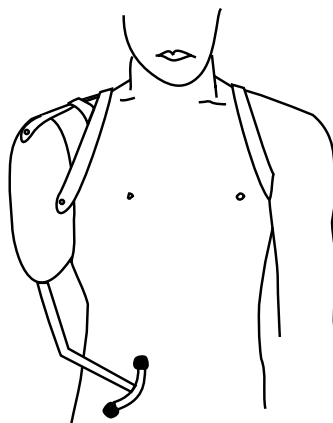

Fig. 4.24

4.5 Other Assistive devices for Upper Limb Amputations

In some cases the use of a universal cuff or strapping system to hold a tool or instrument on the amputated arm can provide some independence at a very low cost. The device is a simple strap with or without elastic with a pocket built in for the tool to be used. Many different utensils can be placed in a cuff. For example a pen, eating utensils, hair brush etc.. (Figure 4.25)



Fig. 4.25

5

Training to Use the Lower Limb Prosthesis

5.1 Exercises Before Walking

A person with a lower extremity amputation who is beginning to walk again must learn some basic skills with the prosthesis to make it easier and more enjoyable to walk. The basics involve being able to properly shift bodyweight onto the prosthesis and balance on the prosthesis. Doing the following exercises in front of a full length mirror will allow the person to view her posture and movements better.

5.1.1 Shifting Bodyweight from Side to Side

- Start by standing with both hands supported (such as on two chairs or in a door frame), place the bodyweight on both feet equally. (Figure 5.1a)
- Then shift the weight onto the prosthesis, moving the hips/trunk over the prosthetic foot, and then returning back to equal weight. (Figure 5.1b) Repeat 30 times. Important: DO NOT lean over to the side, stand tall.
- When this becomes easy, repeat the exercise holding on with one hand, and then try it without arm support. For a greater challenge, try the exercise with the eyes closed.

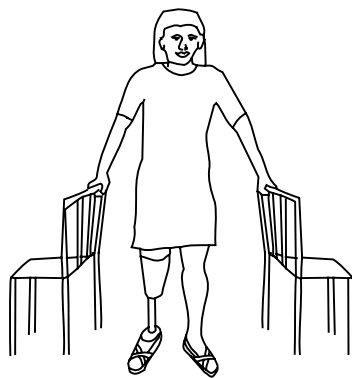

Fig. 5.1a

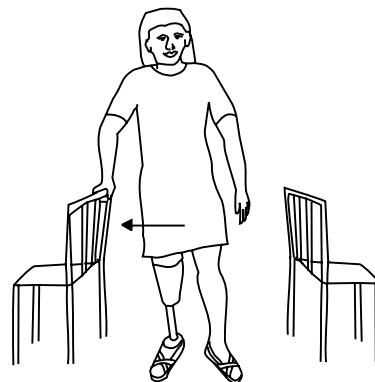

Fig. 5.1b

5.1.2 Shifting Bodyweight from the Heels to the Toes

- Stand with the hands on stable support surface. For example, the back of a chair or parallel bars.
- Then move the bodyweight forward until it is on the toes (Figure 5.2a) and then roll back to the heels. (Figure 5.2b)
- Progress by holding on with one hand and then no hands.
- Repeat 30 times.

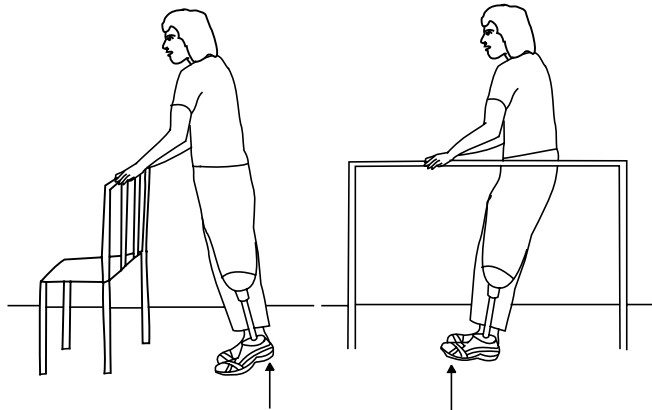

Fig. 5.2a

Fig. 5.2b

5.1.3 Weight Shifting onto the Prosthesis

- Stand with hands on a support surface as previously.
- Step forward with the prosthetic foot.
- Then shift the weight from the back foot to the front foot, until it is flat on the floor. Repeat 30 times
- Repeat this exercise with the other leg forward.

5.1.4 Stepping up with the Intact Leg

- Stand in front of a 10 to 20 cm height step with both arms supported.

- Then shift the weight onto the prosthetic leg, and step up with the intact leg.

Note: One should not bend too far forward, try to stand tall. Repeat 30 times.

- Progress by repeating the exercise with single arm support only (figure.5.3), and then try with no hands. Increase difficulty by using a higher step.

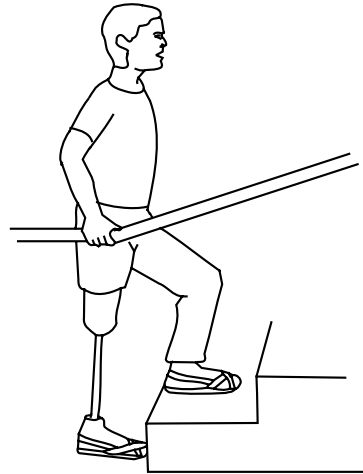

Fig. 5.3

5.1.5 Balancing the Intact Leg on a Ball

- Stand with the intact leg on top of a sturdy ball, with both arms supported.
- Keeping the foot on the ball move it forward and backward, then side to side. Repeat 20 times each direction. (figure 5.4a) Progress to moving the ball in clockwise, then counter-clockwise circles. Repeat 20 times each direction.

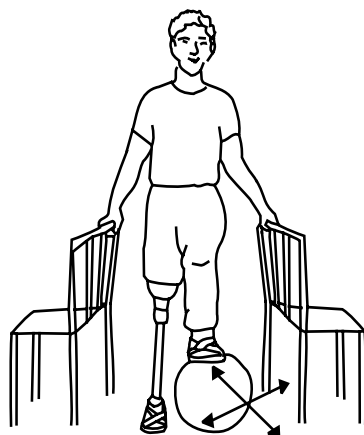

Fig. 5.4a

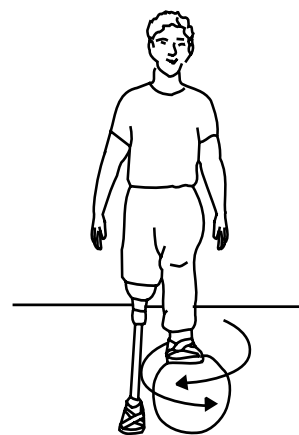

Fig. 5.4b

- Increase the difficulty by using one arm for support, then no hands. Also increase the difficulty by progressing to a harder, smaller ball (Figure 5.4b).

5.1.6 Walking on Two Lines

- Stand with the legs about 15 to 20 cm apart and then have someone make two lines in the dirt or ground starting in front of the feet.
- Practice walking with each foot centered on its' own line. Go back and forth at least 20 times.
- Try not to look down at the ground and still stay on the lines.

5.2 Walking on Level Ground Using a Support Device

A person with a single-leg amputation will need to begin prosthetic walking using a support device such as a walking frame, crutches or cane(s). Learning to walk on uneven ground, up and down stairs and up and down hills are all important. Learning to do these task will make daily activities easier and increase independence.

5.2.1 Walking Frame

- The frame should be no higher than waist level, and high enough to allow the elbows to bend about 15 degrees
- To walk, he should move the frame forward about 20-30 cm, make it steady it with both arms and then step with the prosthesis into the middle of the frame.
- Next, he steps with intact leg just past the toe of the prosthetic foot.
- Walking should be comfortable and done as often as possible to mild fatigue.

5.2.2 Crutches or Canes

- Crutches should be at least three fingers width below the armpits, and canes should be high enough to allow the elbows to be bent slightly. (Figure 5.5)
- Both devices should be placed about 20cm away from the body, to the side.
- A person should move either device forward about 20-30cm and step with the prosthesis between the crutches or canes.
- Next, he steps past the toe of the prosthesis with the intact leg.

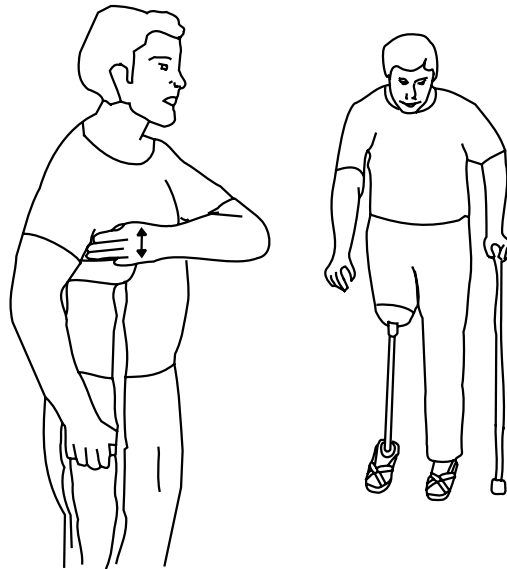

Fig. 5.5

5.2.3 Single Crutch or Cane

- A crutch or cane should be used in the hand opposite the prosthetic side.
- A person moves the device forward about 20-30 cm and steps with the prosthesis.
- Next, he steps past the toe of the prosthesis with the intact leg.

5.3. Going Up and Down Elevations

5.3.1 Steps with a Rail

- Use the crutch or cane in the hand opposite of the rail.
- Going up: Step up with the intact leg first. Then step up with prosthesis. (Figure 5.6a)

Going down: Place crutches or cane down first then step down with the artificial limb. Step down with the intact limb. (Figure 5.6b)

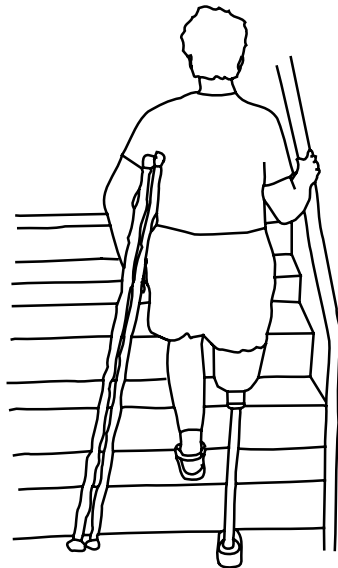

Fig. 5.6a

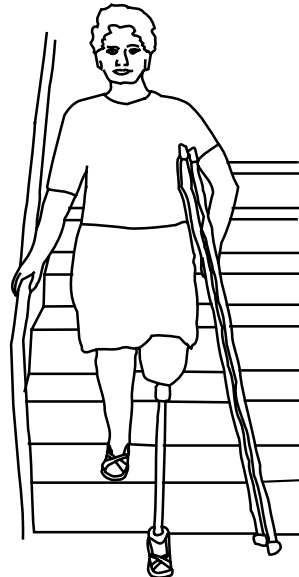

Fig. 5.6b

5.3.2 Going Up and Down a Curb

- Use a cane, walking frame or crutch to go up and down a curb.
- Going up: Place the walking frame or one of the canes/crutches up onto the single step first. Step up with the intact leg first. Then step up with prosthesis. (Figure 5.7a)
- Going Down: Place the cane, crutch or walking frame down first. Step down with the artificial leg. Then bring the intact leg down. (Figure 5.7b)

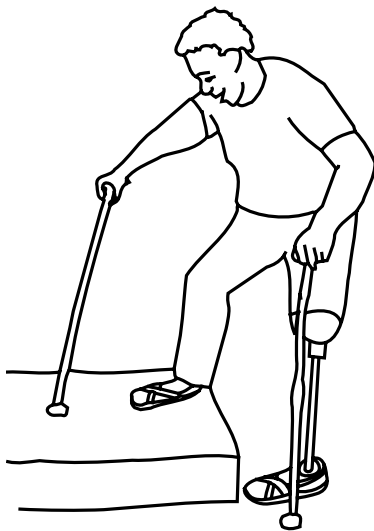

Fig. 5.7a



Fig. 5.7b

5.3.3 Going Up and Down a Ramp, hill or incline

- Use a cane, crutch or walking frame to go up and down a ramp, hill or incline.
- Going up: Places the crutch, cane or walking frame forward. Lean forward and step up with the intact leg first. Then step up with prosthesis.
- Going Down: Place the crutch, cane or walking frame down first. Then lean slightly back and step down with the prosthesis first. Bring the intact leg down.
- For steep inclines or hills it is easier to go up and down side ways. To go up stand with the artificial leg on the lower surface and lead with the intact leg.

Going down lead with prosthesis first. (Figure 5.8)



Fig. 5.8

5.4 Managing Prosthetic Socks

Prosthetic socks are worn between the skin and the prosthetic socket. The purpose of the socks is protect the skin and to keep the prosthetic socket fitting well.

The size and shape of the stump will change over time. As the limb heals the swelling or edema will decrease and the muscles of the limb will start to waste away. This will cause the limb to become smaller. The person with an amputation will have to add socks to the limb to take up the space in the socket so that it continues to be tight. Also if the person with an amputation gains weight or if the limb becomes swollen he will have to decrease the sock thickness so that he can get all the way into the socket.

Making sure that the socks are the correct thickness (ply) will ensure that the prosthesis fits comfortably and does not irritate the limb. Make daily checks to see if the socks are the correct thickness. Some people will have to change sock ply from day to day while others may rarely have to change the sock ply.

The following are signs that the amount of socks that are used is incorrect:

- When standing the prosthesis feels loose or very tight.
- A new or unusual pain is felt after putting on prosthesis.
- For the below knee amputation there is a pain in the knee cap, the top of the shin bone or the end of the shin bone.
- For the above knee amputation there is pain is in the groin, buttocks or end of the thigh bone.
- A blister or bruise forms after wearing the limb.
- There is discoloration that lasts longer than 30 minutes after the prosthesis is removed.

Socks may be added or taken off to improve the situation (See the guidelines on the next page). It should be noted however that some problems may require that changes be made to the socket's shape or the prosthesis' alignment. If the problem is not corrected after trying to correct the thickness of socks, the prosthetics service provider should to be consulted.

Never use a stump shrinker or soft dressing as a sock. These should be removed before putting on the prosthesis.

5.4.1 Managing the Prosthetic Socks with a Below Knee Amputation

In addition to all the signs that we discussed on the previous page, red marks on the residual limb of a below knee amputation can also help the person to know if they are wearing the correct amount of socks. The following guidelines can be used.

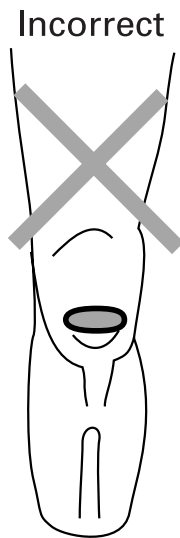

Fig. 5.9a

Problem:

Red mark is on the knee cap and/or there is pain at the end of the shin bone

Reason:

Not enough sock thickness

Solution:

Add sock(s)

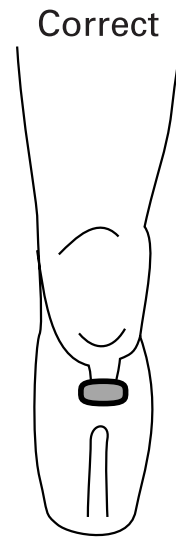

Fig. 5.9b

No problem:

This is the desirable situation. The red mark is on the tendon between the knee between the bottom of knee cap and the top of the shin bone

Reason:

The amount of socks is correct

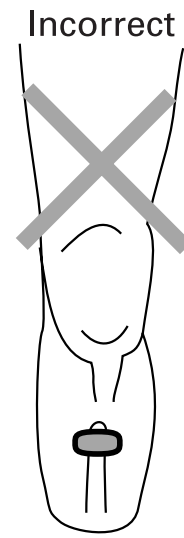

Fig. 5.9c

Problem:

Red mark is on shin bone or there is pain on the top of the shin bone

Reason:

Too much sock thickness

Solution:

Take off socks

5.4.2 Managing the Prosthetic Socks with an Above Knee Amputation

In addition to all the signs that we discussed on the previous page, pressure on the residual limb of an above knee amputation can also help the person to know if he is wearing the correct amount of socks. Because there are different types of socket designs for the above knee prosthesis the guidelines will be different. The following guidelines can be used for a person with a quadrilateral socket:

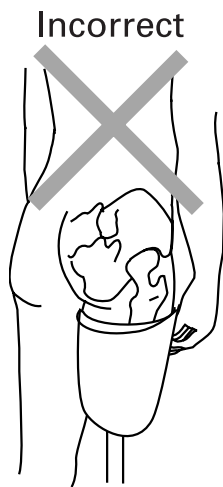

Fig. 5.10a

Problem:
Buttocks bone is above the shelf

Reason:
Too many socks

Solution:
Reduce sock thickness

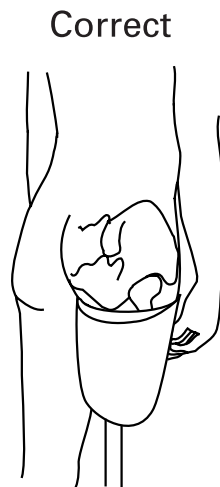

Fig. 5.10b

No problem:
This is the desirable situation. Buttocks bone is on the shelf

Reason:
Correct amount

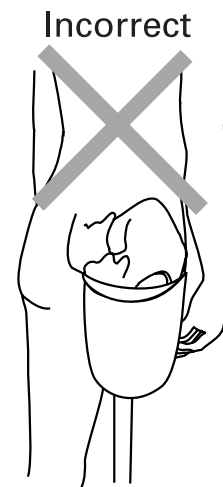

Fig. 5.10c

Problem:
Buttocks bone inside the socket
Pain may be felt in the groin or at the end of the bone

Reason:
Not enough socks

Solution:
Add sock thickness/socks

6

The Child with an Amputation

Children who have had an amputation have different needs, different complications and different outcomes than those of adults with a limb amputation. Therefore, the treatment of a child with limb loss is different than the treatment an adult with limb loss.

6.1 Causes of Childhood Amputation

In children, being born with an absent or **malformed limb (congenital limb deficiency)** is the main cause of limb amputation, followed by trauma and then tumors.

Congenital amputations are generally classified as either **transverse** or **longitudinal**. In a **transverse congenital deficiency** the limb segment develops normally until a certain level with no bony development beyond that level. The amputation is named by the level where the bone.

A **longitudinal deficiency** is the absence or malformation of the long axis of the bone with normal or partial segments of the skeleton existing beyond the malformation. These are named by starting with the proximal bone affected, describing whether the bone is partially or fully affected and continuing distally. All involved bones are named and categorized as partial or complete absence. For example: a child born without a tibia or part of the first ray would be classified as longitudinal tibia total tarsus partial Ray 1 partial. When there is a longitudinal limb deficiency the limb is either significantly shorter, or it may not be able to withstand weight bearing. In the case of the limb being shorter, the distal part of the limb is often times present and can appear normal. However, the shortened limb is treated like an amputation and a prosthesis is used to lengthen the functional part of the limb. If the deficient limb is full length but cannot withstand weight bearing, a surgical amputation is necessary to allow the child to walk using prosthesis.

The cause of congenital limb deficiency is largely unknown. The development of limb buds occurs between weeks three and seven of pregnancy. It is believed that deficiency occurs during this period, but in 70% of cases no cause can be identified. Some factors that have been identified as causing malformation are irradiation, thalidomide, contraceptives and in some cases genetic factors.

Amputation due to trauma is most commonly the result of vehicular and railroad accidents, burns and infections. In countries previously devastated by war, land mines and pieces of ammunition are the primary causes of injuries that result in limb amputation among children. Since children usually have smaller body frames than adults the impact of landmine explosion will result in much higher amputation levels than with an adult.

Tumors, especially of the bone (**Sarcoma**) result in surgical amputation to save the child's life and limit the spread of cancer cells. They most commonly occur after age 15, in the later teen-age years.

Basic differences between the child and an adult with an amputation are; a) the child's potential for further growth, b) the potential for bone overgrowth d) treatment interventions and c) the emotional and psychological issues that will affect a growing child.

6.2 Normal Growth and Development

The child with a limb amputation presents a more difficult challenge to the healthcare provider due to the potential for continuing growth and development. This generally affects two areas. The first being the change in overall length of the residual limb. A thigh segment that is 80% of the length of the non-amputated limb immediately after an above knee amputation, may only be 20% of the total length of the thigh after the child reaches full height. This will have significant effect on the ability to use and control prosthesis. It is very important to preserve as much of the limb length as possible at the time of the amputation.

The second is that children's limbs will naturally change size and shape quickly due to normal growth. This will necessitate more frequent prosthetic socket changes and limb length assessments. Because of the frequent changes there is an added cost to maintaining the child in a properly fitting prosthesis.

6.3 Bony Overgrowth

If the stump contains portions of the digits, as in a congenital deformity, or contains the area of the bone where growth takes place (the **growth plate**) it is essential to observe the end of the bone for the possibility of overgrowth.

This is the most common complication in a child with an acquired amputation. The problem will be evident by age 12 and can result in painful skin stretching and ulceration. This problem is critical if it occurs over a weight-bearing surface such as the end of the thigh bone (femur)

or shin bone (tibia). Of lesser concern, but still a problem, is its' presence in the arm or forearm. To manage a child with existing or potential bony overgrowth, focus on preventing excess weight bearing on the end of the limb. Avoiding direct end weight bearing is critical. This problem is noted when the prosthetic limb is not long enough for the patient's limb. Frequent prosthetic adjustments to prevent this problem are necessary. Surgery is the treatment of choice, especially if modifying the prosthesis cannot relieve the problem of weight-bearing.

6.4 Treatment

6.4.1 Prosthetic Considerations

Children with amputations are not small-scale adults. Although prosthetic fitting for the limb deficient child is similar to the adult with an amputation, there are many differences to consider. The greatest consideration should be the anticipation of adjustments for future growth at the time of prosthetic fabrication. This can maximize the life span of the device and reduce cost. The child will require frequent adjustments to the prosthesis to accommodate changes in circumference and/or length of the stump. The use of multiple layers of socks and soft end pads at the time of prosthetic fabrication is a simple, but effective, intervention to achieve this. Also the prosthesis will need adjustments to the length to accommodate body height growth and avoid limb length inequality. This is important to prevent development of **spine curvature (scoliosis)** or gait alterations that will be difficult to correct later. The type and variety of prosthetic components available for the child are limited, and frequent replacement because of wear and tear in an active child will significantly increase the frequency and cost of care. Evaluation of the child on a quarterly basis, when possible, is necessary to assure adequate prosthetic fitting.

Another thing to consider for the very young child or the child born without limbs is when to introduce the prosthesis. There are no absolute answers to this question. When a child receives the prosthesis will depend on whether or not the child's family has the financial means to frequently replace the limb, as a growing child will have to have multiple prosthetic limbs due to rapid growth.

Ideally for the child with lower extremity amputation, the prosthesis is introduced by the time the child begins to pull to stand, around 7 to 9 months. The initial prosthetic may not have a moveable or bendable knee. However, by the age of seven the child will have a normal adult walking pattern and the prosthesis should have a bending knee prior to that age.

For the child with an upper extremity amputation, a cosmetic or passive arm should be introduced shortly after she begins to sit independently. (Age 6-8 months) She may not use the arm initially but encouraging bimanual activities will promote prosthetic use. As the child grows, a moveable terminal device with cable system is introduced and the child should be able to open and close the terminal device by age 18 months.

6.4.2 Treatment

Treatment options for this population should be chosen on the basis of predicting function, comfort, physical appearance, their emotional needs and developmental milestones. Parents and family members are critical parts of the treatment team.

Prior to prosthetic fitting and during infancy in congenital limb deficiencies, the parents are instructed to move the joints through the available range of motions (ROM) at the joints of the limb (please see chapter 2.6.3).

In the lower extremity amputee once the child is standing and the limb is introduced the goal of treatment is to encourage the child to weight bear on the limb. This will improve balance, strength and gait. Game playing is the primary therapy intervention. Games that include reaching, ball playing and football (soccer) can all be modified to encourage singly limb standing. Remember to keep in mind developmental milestones (see table 6.1) and age appropriate activities.

For the child with upper extremity prosthesis, she should first be encouraged to use the prosthesis as an assist to the intact limb. For example, holding a large ball or toy with both hands. Once the cable and terminal device are receive, manipulation activities should begin.

Age achieved:	Milestone:
5 to 8 months	Sitting without support
5 to 12 months	Pulls to stand
4 to 8 months	Transfers object one hand to the other
9 to 16 months	Stands alone
9 to 17 months	Walks alone
15 to 30 months	Stands on one foot alone
12 to 18 months	Throws a ball
12 to 18 months	Begins to run
18 to 24 months	Kicks a ball
18 to 24 months	Jumps with both feet

Table 6.1

In cases in which both arms are absent, the child will often learn to complete all activities of daily living with his feet. For successful prosthetic fitting to occur give the child the prosthesis as early as possible and involve parents to encourage use on a daily basis. The more activities a child learns to do without a prosthesis, the less likely he is to use a prosthesis.

6.5 Emotional and Psychological issues

Children with an amputation will need to work with their family members in the adjustment to a new body image. Doll playing for children younger than seven years and quiet discussion with older children with amputation may be a benefit. Topics that should be discussed include how the child feels about the way they look, how other people react to the child's appearance, and their ability to play and fit in with other children. As the child approaches teen-age years issues of sexuality and appearance may reappear and efforts should be made frequently to address these topics.

Often the child will react to the amputation in the same way that the adult in his life reacts. If the family of the child feels that the his has limited ability and cannot fully participate in life then the child will often limit himself.

Ideally, the child should be encouraged to participate in age appropriate activities and sports within his ability. Participation in sports and school activities also help to improve and maintain self-esteem.

Often times, it is helpful to teach the child's peers or classmates about the prosthesis, the cause of the amputation, and treatments, so they are not frightened or intimidated by the prosthesis. A discussion with teachers about "show and tell" in the classroom is often helpful for both the child and his peers. The discussion can be led either by the child himself showing the prosthesis and answering questions, or the parents and teacher.

Although the child should always be encouraged to participate with their able bodied peers, many children benefit from meeting other children with amputations or adult role models with amputation. Whenever possible, healthcare workers or support groups are encouraged to host activities such as sports days, picnics or camps for children with an amputation to that they can meet and socialize with children and adults with similar problems.

Addendum: Daily Reminders for Persons with Amputations

The following should be done each day:

Do not use tobacco products

Caring for the Skin:

1. Wash the stump daily and massage the skin and scars.
2. Place lotion on limb.
3. Inspect the skin after wearing the prosthesis.
4. Always wear a bandage to decrease the swelling when the prosthesis is not being worn.
5. Do the exercises daily and avoid positions that may lead to contractures of the joints.
6. Always wear proper fitting shoes and do not change the heel height of the shoes
7. If you lost your limb because of a disease, examine the other foot carefully.

Using the prosthesis:

1. Wear the prosthesis daily and gradually increase the amount of time it is worn until it is worn all day. Do not sleep in the prosthesis.
2. Check the prosthesis for signs of wear and tear or looseness of parts. Return to the prosthetics service provider if there are problems. When the service is distant and the work that is needed is minor (such as tightening a screw or rivet) have a local craftsman or mechanic repair the problem. If major repair is required return to the prosthetics service provider.
3. Clean the socket daily with soap and water.
4. Check to make sure that the number of socks is correct.
5. Clean the prosthetic socks with soap and water and let them dry completely before using again

The following should be done periodically:

1. Return to the prosthetics service provider on a yearly basis to have maintenance done on the prosthesis.

2. For the upper limb prosthesis the terminal device may need to be relined with rubber.
3. For the child with amputation the prosthesis should be evaluated every three months to monitor growth changes.
4. Maintain stable body weight, avoid weight gain or loss. Avoid obesity.

References:

1. Meier RH Upper Limb Amputee Rehabilitation in PM&R State of the Art Reviews; A. Esquenazi (ed.). 8; 1:165-185, February 1994.
2. Malone, J.M., Snyder, M, Anderson, G., Bernhard, V.M., Holloway, G.A., & Bunt, T.J. Prevention of amputation by diabetic education. The American Journal of Surgery, 1989; 158: 520-524.
3. Coleman WC: Footwear in a management program for injury prevention . In Levin ME, O'Neal LW, Bowker JH (eds): The Diabetic Foot. St. Louis. Mosby. 1993; 531-547.
4. Gottschalk F. Transfemoral Amputation, Surgical Considerations in Atlas of Limb Prosthetics. Bowker JH and Michael JW(eds). St. Louis. Mosby, 1992; 501-507.
5. Pinzur, M.S., Smith, D.G., Daluga, D.J., & Osterman, H. Selection of patients for through-the-knee amputation. The Journal of Bone and Joint Surgery, 1988; 70-A(5): 746-750.
6. Burgess EM, Romano RL, Zettl JH: The Management of Lower-Extremity Amputations. TR 10-6, US Government Printing Office, Washington, DC, August 1969.
7. Davis R: Phantom sensation, phantom pain and stump pain. Arch Phys Med Rehabil 1993; 74:79.
8. Kamen L B, Chapis G J. Phantom Limb Sensation and Phantom Pain in PM&R State of the Art Reviews; A. Esquenazi (ed.). 73-88; 8, 1, February 1994.
9. Long I. A.: Normal Shape-Normal Alignment (NSNA) Above-Knee Prosthesis. Clin. Prosthetics Orthotics, 1985; 9:9-14.
10. Esquenazi A. Geriatric Amputee Rehabilitation. Clin. Geriatric Med. 1993; 9(4):731-743.
11. Esquenazi A, Torres M. Prosthetic Feet and Ankle Mechanisms. Phys Med and Rehab Clinics of North America, 1991; 2 (2): 299-309.
12. Czernieki J M and Gitter AJ. Prosthetic Feet: A Scientific and Clinical review of Current Components in PM&R State of the Art Reviews; A. Esquenazi (ed.). 8, 1: 109-127 February 1994.
13. Michael J. Prosthetic Knee Mechanisms: PM&R in PM&R State of the Art Reviews; A. Esquenazi (ed.). 8, 1: 147-164 February 1994.
14. Leonard J. A. Jr. Lower Limb Prosthetic Sockets in PM&R State of the Art Reviews; A. Esquenazi (ed.). 8, 1: 129-145 February 1994.
15. Dise-Lewis Jeanne Psychological Adaptation to Limb Loss in Comprehensive Management of the Upper-Limb Amputee. Atkins J D, Meier III H R., (edts). Springer-Verlag, New York, 1989.

16. Bohne WHO: Atlas of Amputation Surgery. New York. Thieme Medical Publishers, 1987; 160-174.
17. Malone JM, Fleming LL, Roberson J, et al: Immediate, early and late postsurgical management of upper limb amputation. J Rehabil Res Dev, 1984; 21:33.
18. Esquenazi A. Upper Limb Amputee Rehabilitation and Prosthetic Restoration in Textbook of Physical Medicine and Rehabilitation. Braddom R. (edt) W. B. Saunders 1995.
19. Esquenazi, A. Upper Limb Amputee Rehabilitation and Prosthetic Restoration. In Physical Medicine and Rehabilitation, 2nd ed. R.L. Braddom (edt.) W.B. Saunders Co., Philadelphia, PA 2000, Chapter 13 pp 263-278.
20. Esquenazi A, Wikoff E, Lucas M. Amputation Rehabilitation in Physical Medicine and Rehabilitation, The Complete Approach. Chapter 93 Grabois M (edt) Blackwell Science 2000. 1744-1760
21. Gailey, R.S. One Step Ahead An Integrated Approach to Lower Extremity Prosthetics and Amputee Rehabilitation (1994)
22. Meier RH: Amputation and prosthetic fitting. In Fisher SV, Helm PA (eds): Comprehensive Rehabilitation of Burns. Baltimore, Williams & Wilkins, 1984; 267-310.
23. Brenner CD: Wrist disarticulation and transradial amputation/ Prosthetic principles. Chapter 8B in BowkerJH, Michael JW (eds): Atlas of Limb Prosthetics Surgical, Prosthetic, and Rehabilitation Principles. Second Edition. St. Louis. CV Mosby, 1992; 241-249.
24. Houston C, Dillingham MD, Esquenazi A. Rehabilitation of the Lower Lomb Amputee in Rehabilitation of the Injured Combatant. Vol 1. Textbook of Military Medicine. Office of the Surgeon General, The Borden Institute, Washington DC 1998.
25. Cooper R: Shoulder disarticulation and forequarter amputation/ Prosthetic principles. Chapter 10B in Bowker JH, Michael JW (eds): Atlas of Limb Prosthetics Surgical, Prosthetic, and Rehabilitation Principles. Second Edition. St. Louis. CV Mosby, 1992; 271-275.

World Health Organization Documents:

26. Training in the Community for People with Disabilities (1989) (E.F. & Arabic)
27. Prosthetic and Orthotic Services in Developing Countries- A Discussion Document (WHO/DAR/99.1 (E.))
28. Guidelines for Training Personnel in Developing Countries for Prosthetic and Orthotic Sevices (WHO/RHB/90.1 (E. &F.))
E= English, F= French