

# EXERCISES FOR LOWER-LIMB AMPUTEES

Gait training



gtz



ICRC



**ICRC**

International Committee of the Red Cross  
19, avenue de la Paix  
1202 Geneva, Switzerland  
T + 41 22 734 60 01 F + 41 22 733 20 57  
E-mail: [shop@icrc.org](mailto:shop@icrc.org)  
[www.icrc.org](http://www.icrc.org)  
© ICRC, September 2008

# Table of contents

<b>Introduction</b>	4
<b>1. Weight bearing and balance</b>	7
1.1 Partial weight bearing (two-hand support)	8
1.2 Partial weight bearing (one-hand support)	9
1.3 Partial weight bearing (fingertip support)	10
1.4 Partial weight bearing (without support)	11
1.5 Partial weight shift (two-hand support)	12
1.6 Partial weight shift (one-hand support)	13
1.7 Partial weight shift (without support)	14
1.8 Partial weight shift (two-hand support)	15
1.9 Partial weight shift (one-hand support)	16
1.10 Partial weight shift (without support)	17
1.11 Pelvic rotation	18
1.12 Sideward walking (two-hand support)	19
1.13 Full weight shift (two-hand support)	20
1.14 Full weight shift (without support)	21
1.15 Heel strike (with or without support)	22
1.16 Handball (with or without support)	23
1.17 Balance board	24
1.18 Obstacle stepping (with or without support)	25
1.19 Football (with or without support)	26
1.20 Handball	27
<b>Notes</b>	28

<b>2.</b>	<b>Specific gait training</b>	31
2.1	Sound-leg step forward (two-hand support)	32
2.2	Sound-leg step backward (two-hand support)	33
2.3	Sound-leg step through (two-hand support)	34
2.4	Sound-leg step through (one-hand support)	35
2.5	Sound-leg step through (without support)	36
2.6	Prosthetic-leg step forward (two-hand support)	37
2.7	Prosthetic-leg step backward (two-hand support)	38
2.8	Prosthetic-leg step through (two-hand support)	39
2.9	Prosthetic-leg step forward (one-hand support)	40
2.10	Prosthetic-leg step through (without support)	41
2.11	Walking between the parallel bars (one-hand support)	42
2.12	Walking between the parallel bars (without support)	43
	<b>Notes</b>	44
<b>3.</b>	<b>Advanced exercises</b>	47
3.1	Bouncing a ball (stationary position)	48
3.2	Bouncing a ball (walking)	49
3.3	Balancing a stick	50
3.4	Balancing on the prosthesis	51
3.5	Walking on an uneven surface	52
3.6	Going up and down a slope	53
3.7	Jumping (for below-knee amputees only)	54
3.8	Running	55
	<b>Notes</b>	56

<b>4. Functional exercises</b>	59
4.1 Rising from a chair	60
4.2 Climbing a staircase	61
4.3.1 Descending a staircase: sound leg step to (for above-knee amputees)	62
4.3.2 Descending a staircase: sound leg step through (for below-knee amputees)	63
4.4.1 Sitting down and getting up from the floor (method 1: forward)	64
4.4.2 Sitting down and getting up from the floor (method 2: backward)	65
4.5 Sitting down on a chair (for bilateral amputees)	66
4.6 Lying down (for bilateral amputees)	67
4.7 Getting up from the floor (for bilateral amputees)	68
4.8 Weight carrying	69
<b>Notes</b>	70
<b>Credits</b>	72
The team	72
Bibliography	72

# Introduction

Physiotherapy plays a crucial role in the post-prosthetic management of lower-limb amputees. However, experience shows that it is neglected or not even available in many physical-rehabilitation centres that receive assistance from the ICRC and other aid organizations. This CD-ROM/booklet seeks to address the problem by providing examples of basic post-prosthetic exercises for use by physiotherapists, physiotherapy assistants, orthoprosthetists and others involved in the gait training of lower-limb amputees.

Prosthetic gait training has several goals: to help amputees adapt to their new condition, to achieve optimal weight bearing on the prosthesis, to improve balance and reaction to disturbance, to restore the optimal gait pattern, to reduce the amount of energy needed to walk (trans-femoral amputees use up to 50% more energy than

non-amputees) and to teach amputees how to perform daily operations like sitting down and walking up and down stairs. All this will help amputees regain their self-confidence and play an active role in society.

It is important that the exercises be built up gradually to reduce the risk of skin abrasions and consequent delays in the fitting process. A progressive, step-by-step approach will also minimize gait defects, which hamper cosmetic and functional restoration.

In administering the exercises, daily hands-on, individual sessions are recommended in addition to group sessions. It is also advisable to work closely with technical prosthetics personnel with a view to jointly assessing the patient's progress and analysing the causes of observed gait defects, preferably on a daily basis.

The exercises are described in four chapters:

1. Weight-bearing and balance exercises
2. Specific gait-training exercises
3. Advanced exercises
4. Functional exercises

In view of the above, patients should be discouraged from walking by themselves as soon as they have been fitted with prostheses, however eager they may be to do so. Instead, they should follow an exercise programme allowing them to improve their abilities gradually.

This booklet presents the basic aspects of gait training, taking into account the constraints often posed by lack of qualified personnel in situations where aid organizations work. Your comments and/or suggestions are most welcome and can be addressed to:  
ICRC Physical Rehabilitation Programmes  
19, avenue de la Paix  
1202 Geneva  
Switzerland  
Tel: + 41 22 734 6001  
E-mail: [icrc.gva@icrc.org](mailto:icrc.gva@icrc.org)

# WEIGHT BEARING AND BALANCE



# 1

## **WEIGHT BEARING AND BALANCE**

It is important to ensure that the patient performs the exercises accurately, always maintaining the correct posture.

# 1.1 Partial weight bearing (two-hand support)

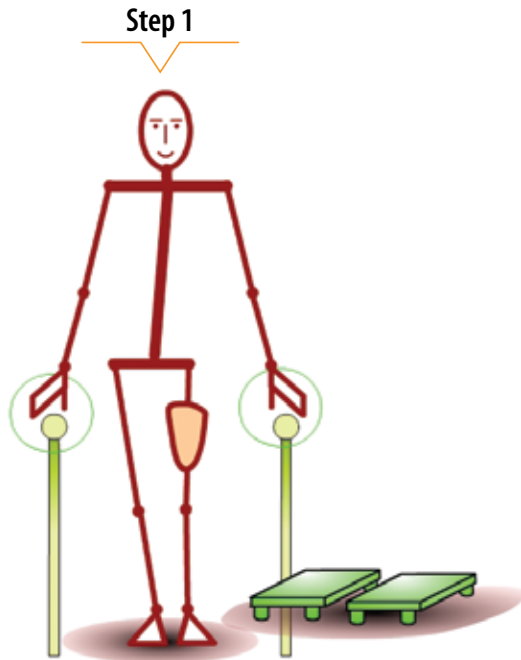

Stand between the parallel bars using both hands to support yourself.

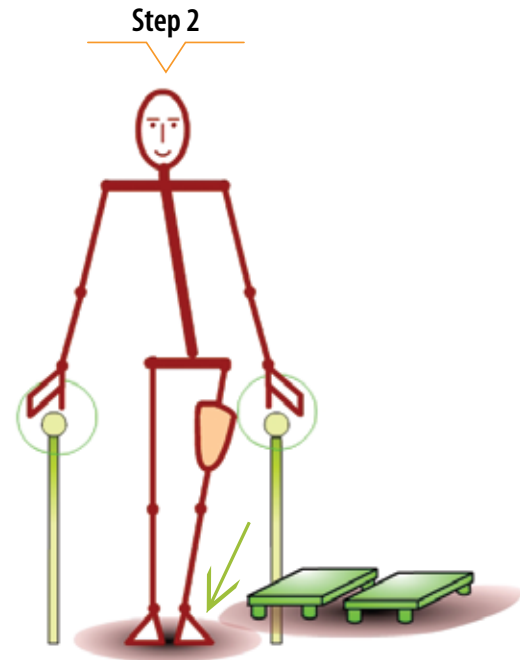

Shift the the body weight from the sound leg to the prosthesis (a pair of scales may be useful to measure the weight shifted).

## 1.2 Partial weight bearing (one-hand support)

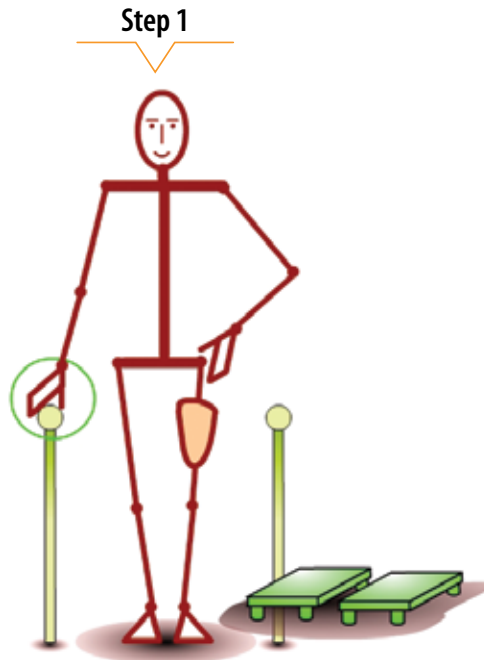

Stand between the parallel bars using one hand to support yourself.

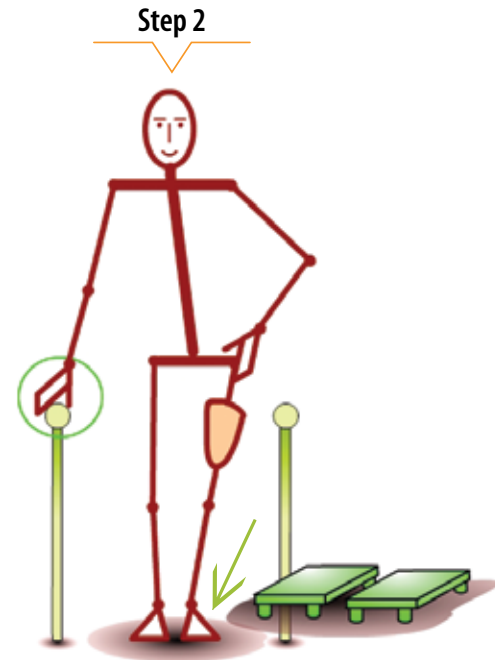

Shift the body weight from the sound leg to the prosthesis. Always use the contralateral hand.

## 1.3 Partial weight bearing (fingertip support)

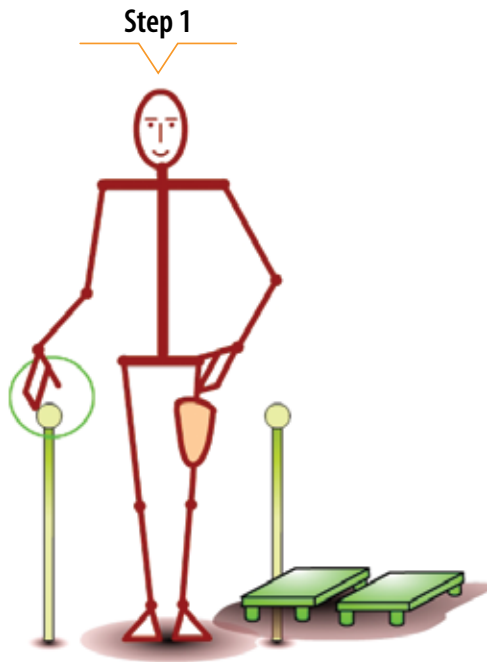

Stand between the parallel bars using only your fingertips to support yourself.

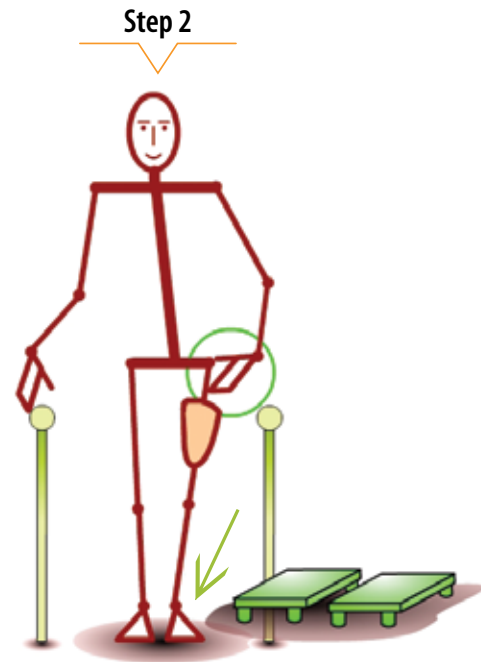

Shift the body weight from the sound leg to the prosthesis (a pair of scales may be useful to measure the weight shifted).

## 1.4 Partial weight bearing (without support)

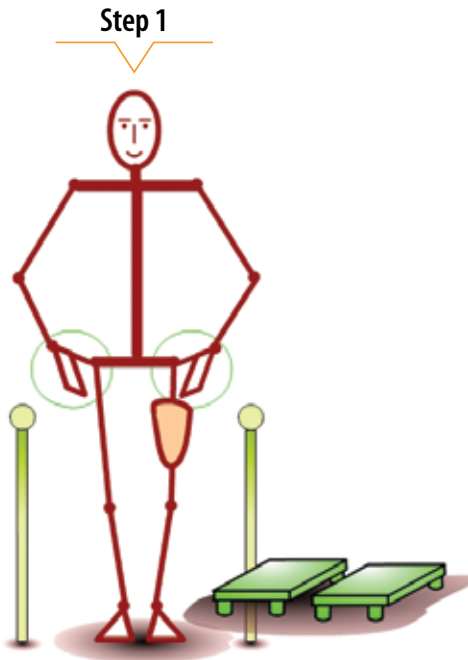

Stand between the parallel bars without support.

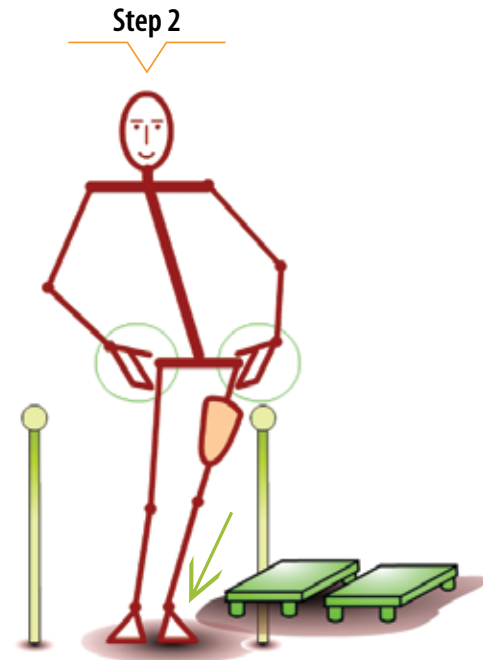

Shift the body weight from the sound leg to the prosthesis.

## 1.5 Partial weight shift (two-hand support)

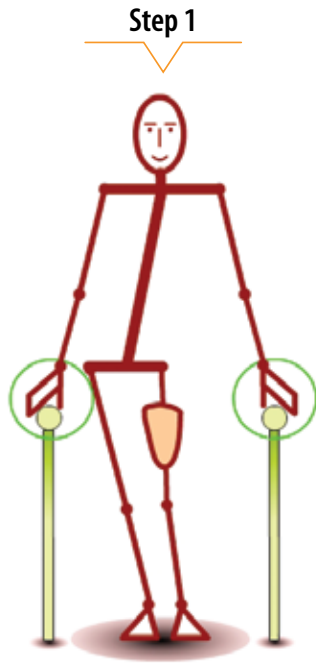

Stand between the parallel bars using both hands to support yourself.

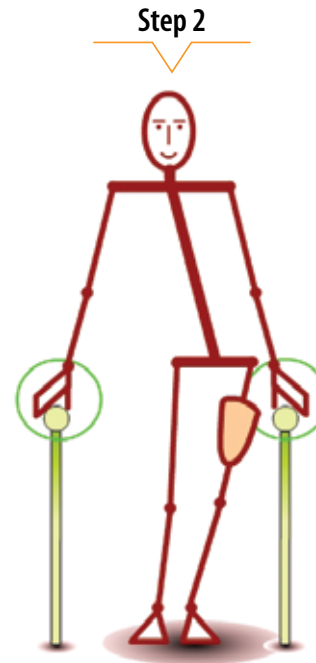

Shift the pelvis from right to left and vice versa, without moving your shoulders.

## 1.6 Partial weight shift (one-hand support)

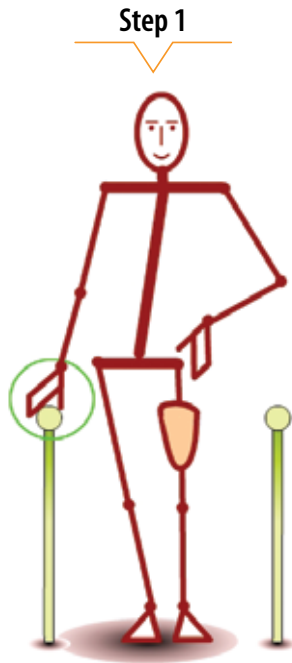

Stand between the parallel bars using one hand to support yourself.

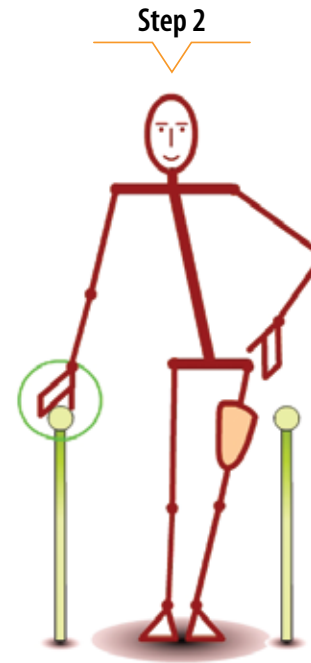

Shift the pelvis from right to left and vice versa. Always use the contralateral hand.

## 1.7 Partial weight shift (without support)

Step 1

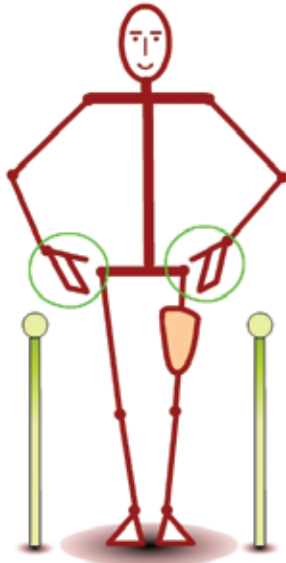

Stand between the parallel bars without support.

Step 2

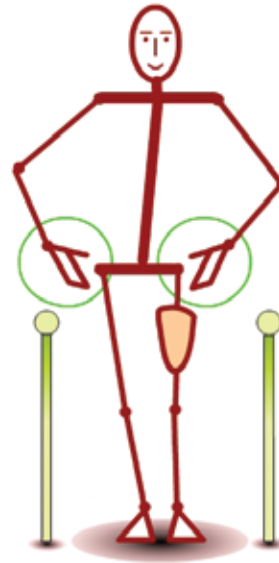

Shift the pelvis from right to left and vice versa, without moving your shoulders.



## 1.8 Partial weight shift (two-hand support)

Step 1

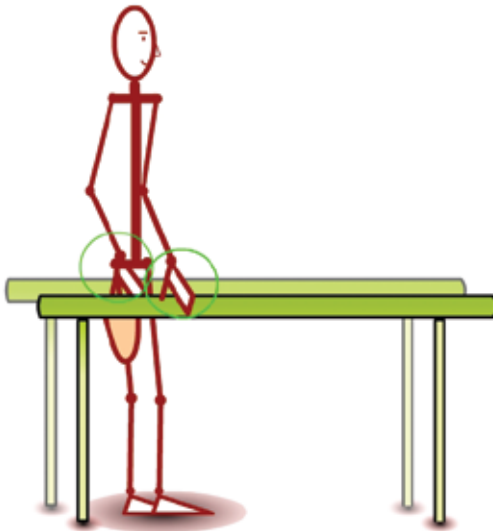

Stand between the parallel bars on both legs using both hands to support yourself.

Step 2

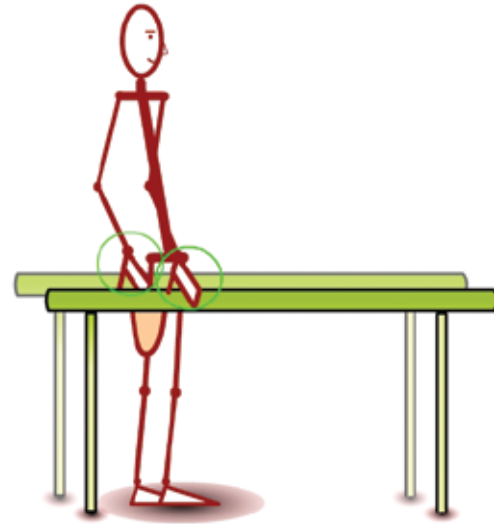

Shift the pelvis forward and backward, without moving your shoulders.

## 1.9 Partial weight shift (one-hand support)

Step 1

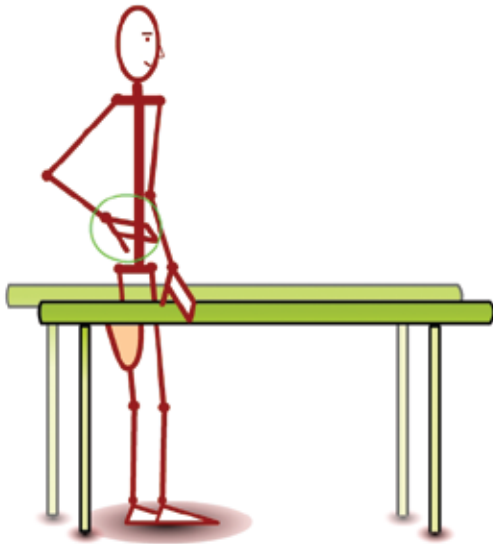

Stand between the parallel bars on both legs using one hand to support yourself.

Step 2

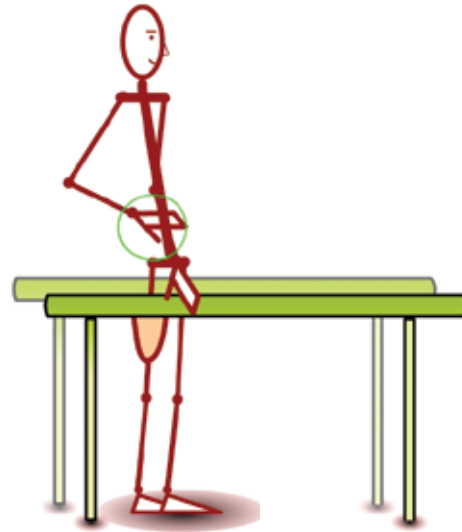

Shift the pelvis forward and backward. Always use contralateral hand.

## 1.10 Partial weight shift (without support)

Step 1

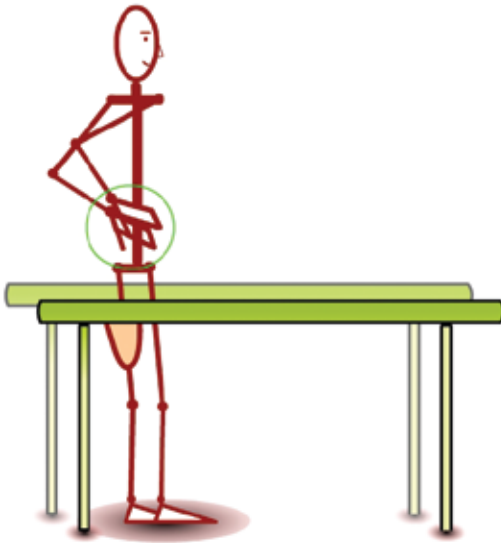

Stand between the parallel bars on both legs without support.

Step 2

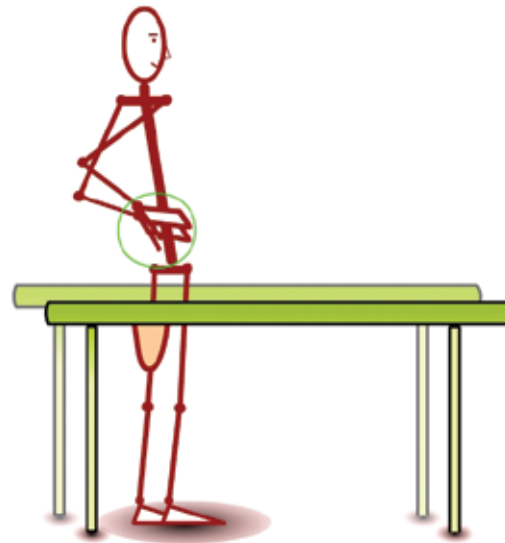

Shift the pelvis forward and backward.

## 1.11 Pelvic rotation

Step 1

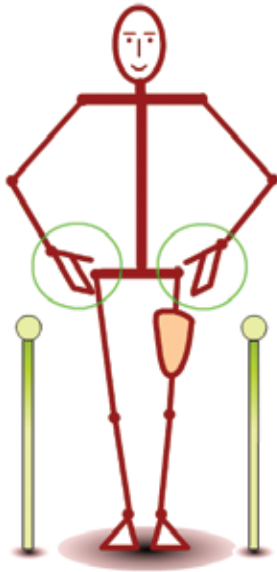

Stand between the parallel bars with or without support.

Step 2

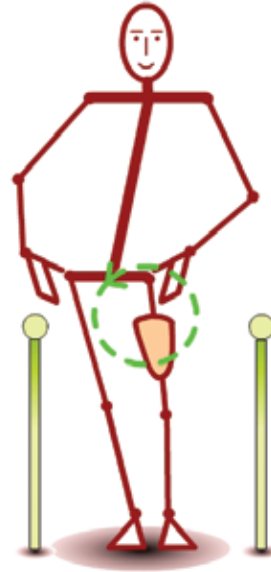

Rotate the pelvis.

## 1.12 Sideward walking (two-hand support)

Step 1

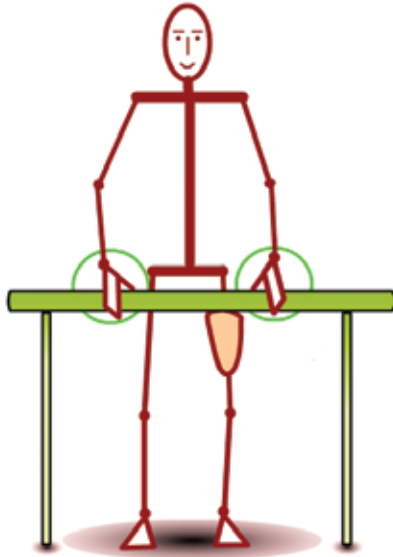

Stand between the parallel bars using both hands to support yourself.

Step 2

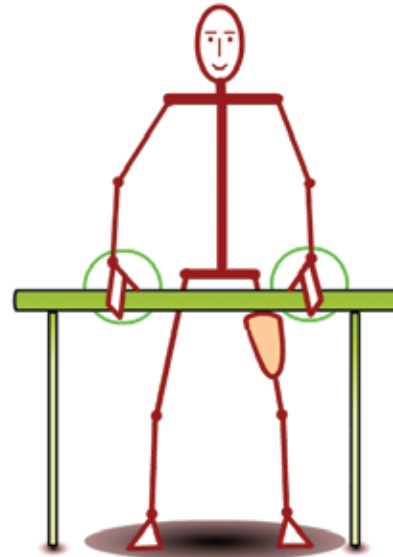

Walk sideways towards the prosthetic side and back.

## 1.13 Full weight shift (two-hand support)

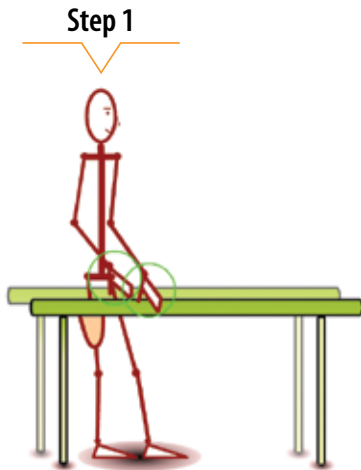

Stand between the parallel bars with one leg in front of the other using both hands to support yourself.

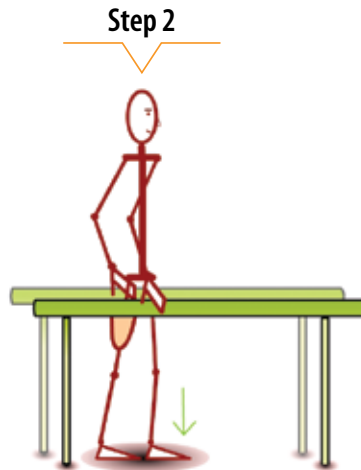

Shift the body weight from one leg to the other by moving the pelvis and trunk from front to back, with or without the support of your arms.

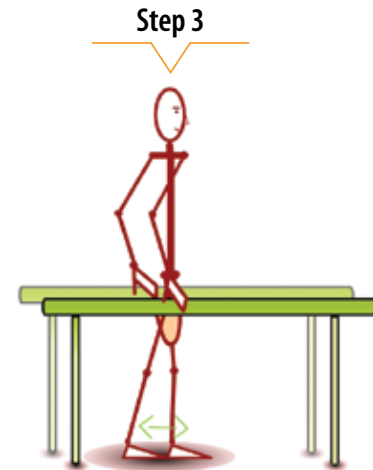

Repeat the exercise, changing the initial position of your legs.

## 1.14 Full weight shift (without support)



Step 1

Step 2

Step 3

Stand between the parallel bars without support and with one leg in front of the other.

Shift the body weight from one leg to the other by moving the pelvis and trunk from front to back, with or without the support of your arms.

Repeat the exercise, changing the initial position of your legs.

## 1.15 Heel strike (with or without support)

Step 1

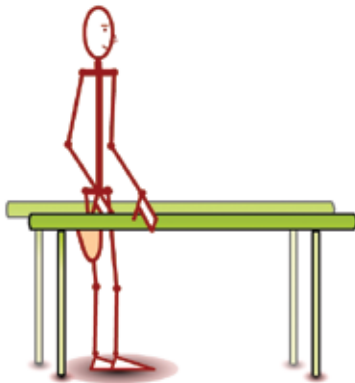

Stand between the parallel bars with or without the support of your hands.

Step 2

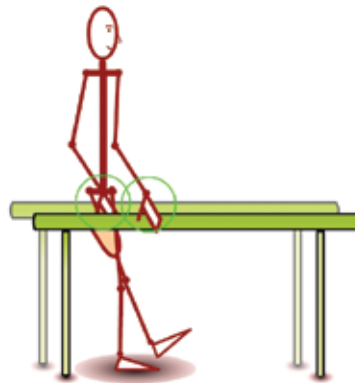

Step forward with the prosthesis.

Step 3



Keep the knee joint straight and push the heel downwards.



## 1.16 Handball (with or without support)

Step 1

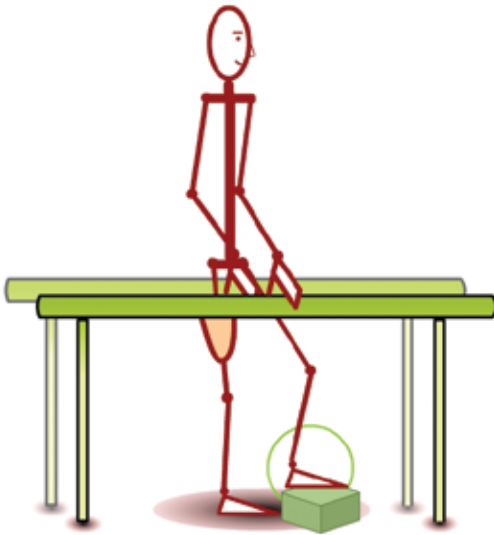

Stand between the parallel bars with or without support; place the sound leg on a raised object.

Step 2



Play catch with the instructor.

## 1.17 Balance board

Step 1

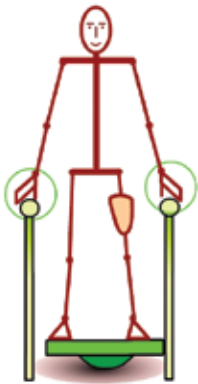

Stand between the parallel bars on a balance board using both hands to support yourself.

Step 2

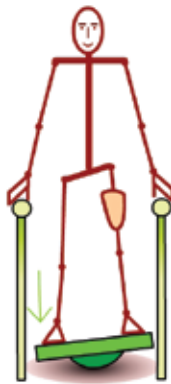

Shift the body weight from one leg to the other.

Step 3

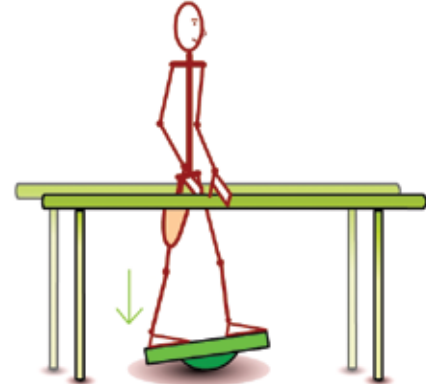

Repeat the exercise, shifting the body weight from front to back.

## 1.18 Obstacle stepping (with or without support)

Step 1

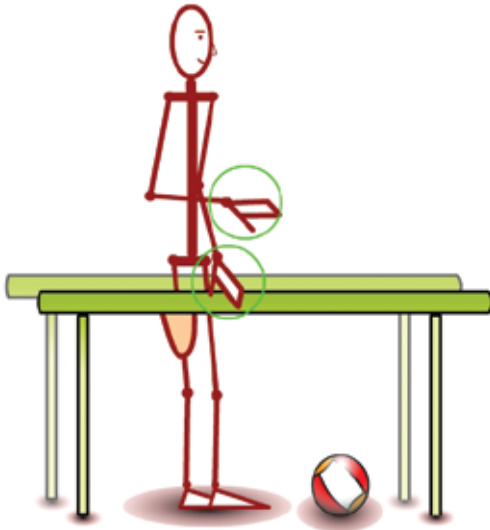

Stand between the parallel bars with or without support.

Step 2

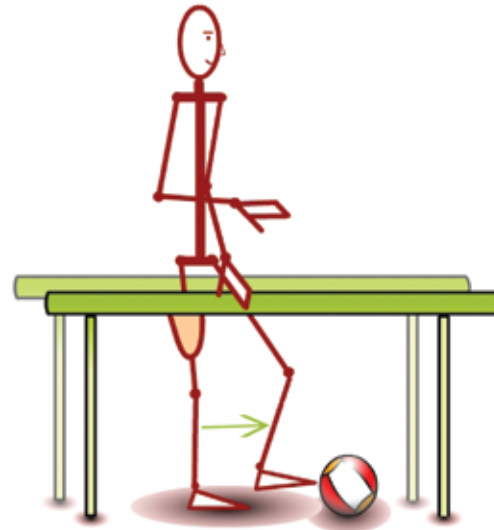

Step over an object with the sound leg.

# 1.19 Football (with or without support)

Step 1

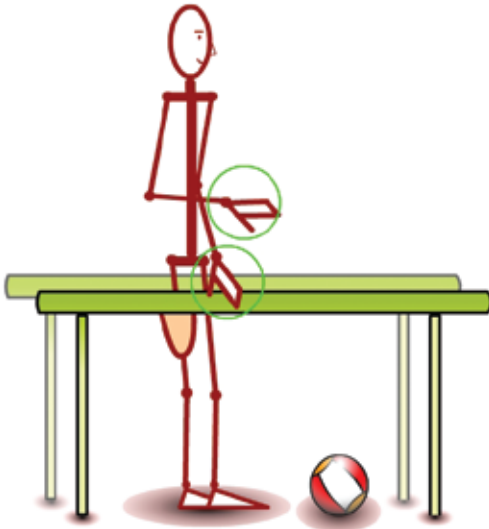

Stand between the parallel bars with or without support.

Step 2

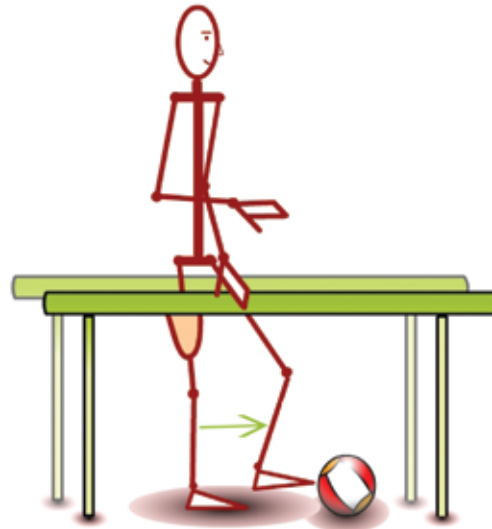

Kick a ball with the sound leg.

## 1.20 Handball

Step 1

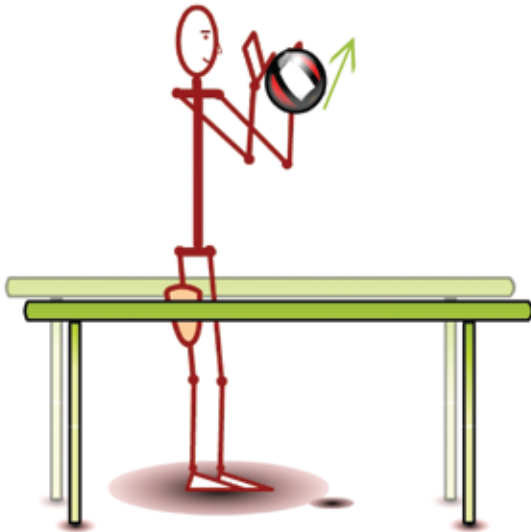

Stand on both legs between the parallel bars.

Step 2

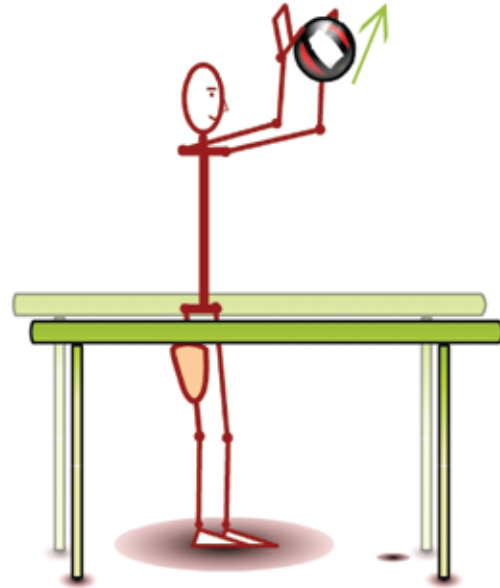

Play catch with the instructor.

# Notes

.....

.....

.....

.....

.....

.....

.....

.....

.....

.....

.....

.....

.....

.....

.....

.....

.....

.....

.....

.....

.....

.....

.....

.....

.....

.....

.....

.....

.....

.....

.....

.....

.....

.....

.....

.....

.....

.....

.....

.....

.....

.....

.....

.....

.....

# **SPECIFIC GAIT TRAINING**



# 2

## **SPECIFIC GAIT TRAINING**

It is important to ensure that the patient performs the exercises accurately, always maintaining the correct posture.

## 2.1 Sound-leg step forward (two-hand support)

Step 1

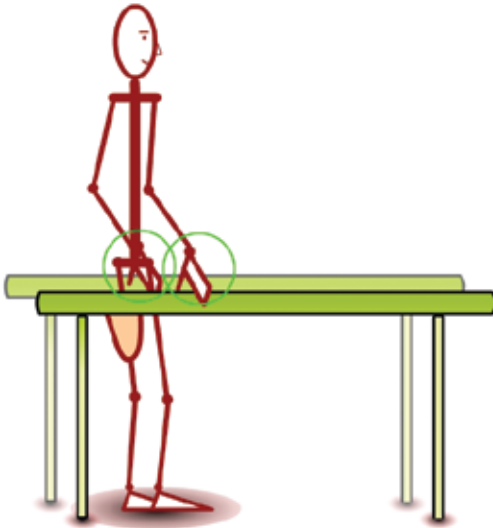

Stand between the parallel bars using both hands to support yourself.

Step 2

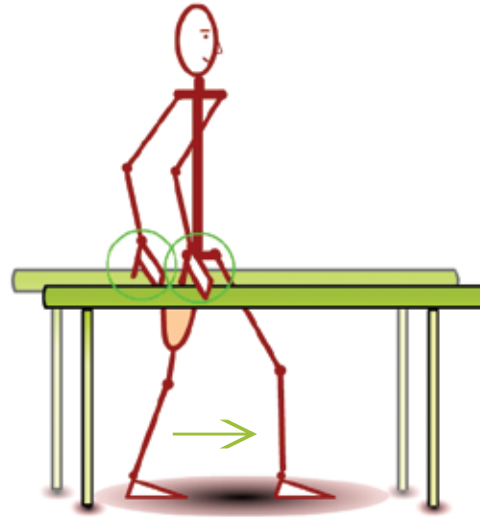

Step forward with the sound leg, keeping hands parallel to the prosthesis.

## 2.2 Sound-leg step backward (two-hand support)

Step 1

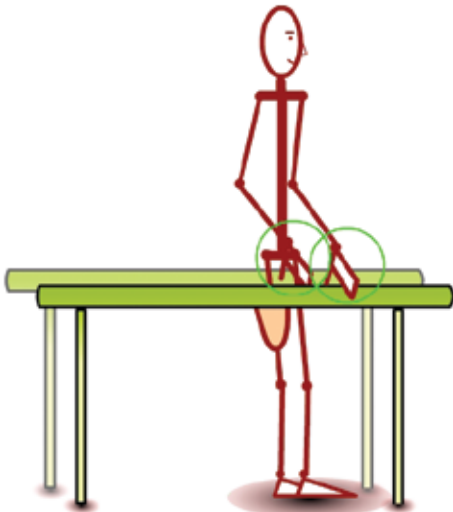

Stand between the parallel bars using both hands to support yourself.

Step 2

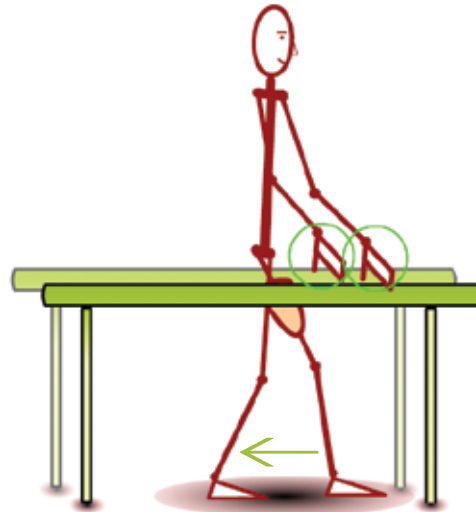

Step backward with the sound leg, keeping hands parallel to the prosthesis.

## 2.3 Sound-leg step through (two-hand support)

Step 1

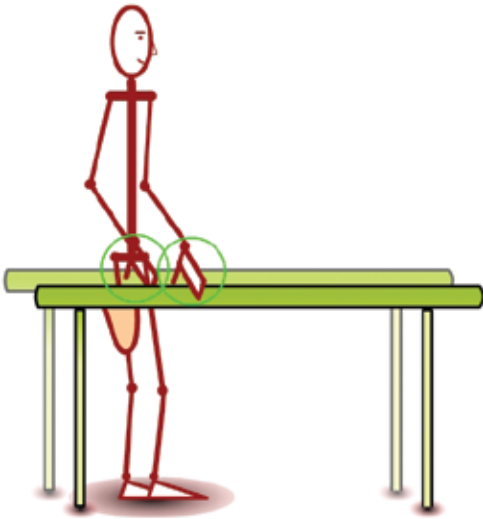

Stand between the parallel bars using both hands to support yourself.

Step 2

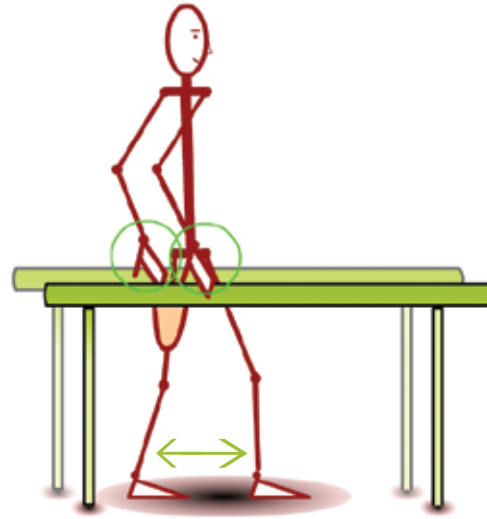

Step forward and backward with the sound leg, keeping hands parallel to the prosthesis. Hold the prosthesis slightly in adduction. Maintain an upright position, allowing the trunk and shoulders to move backward and forward, but without lateroflexion.

## 2.4 Sound-leg step through (one-hand support)

Step 1

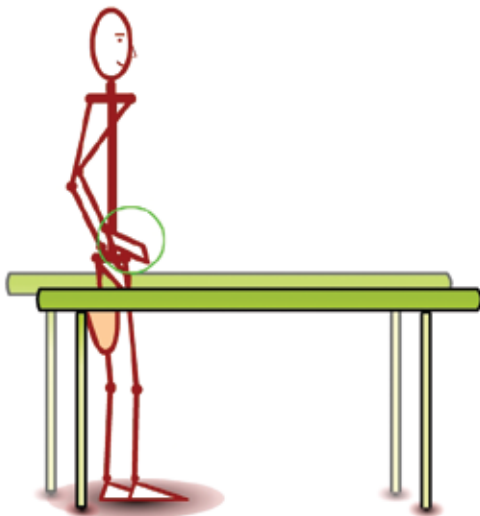

Stand between the parallel bars with support of one hand.

Step 2

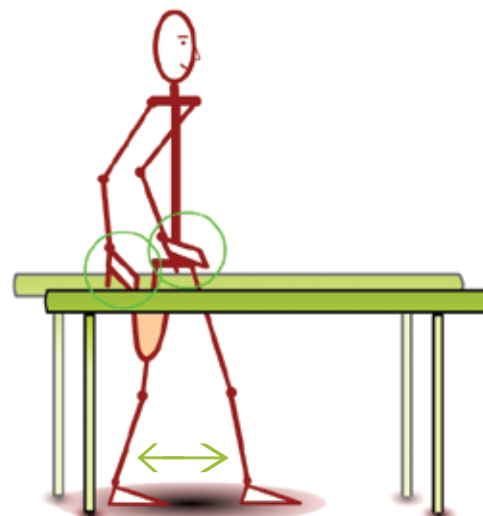

Step forward and backward with the sound leg. Always use the contralateral hand.

## 2.5 Sound-leg step through (without support)

Step 1

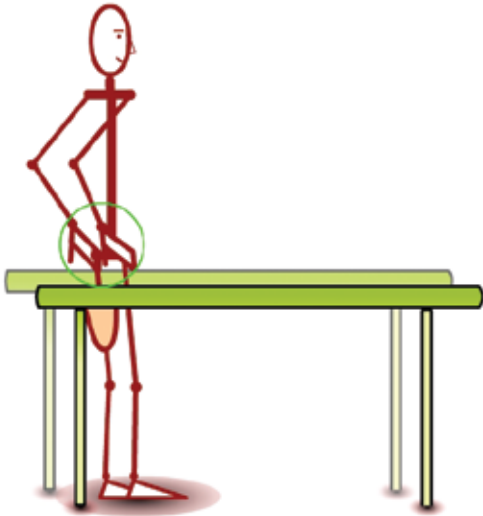

Stand between the parallel bars without support.

Step 2

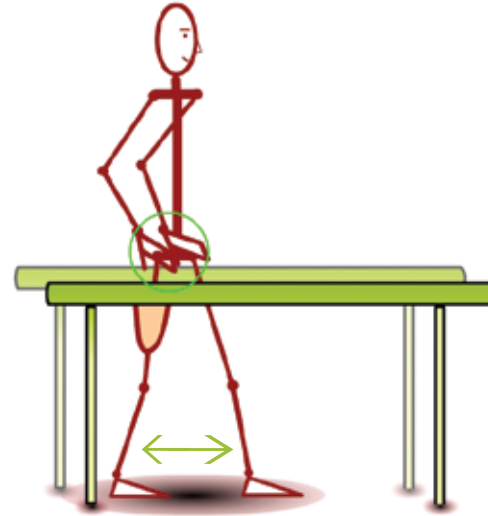

Step forward and backward with the sound leg, holding the prosthesis slightly in adduction. Maintain an upright position, allowing the trunk and shoulders to move backward and forward, but without lateroflexion.

## 2.6 Prosthetic-leg step forward (two-hand support)

Step 1

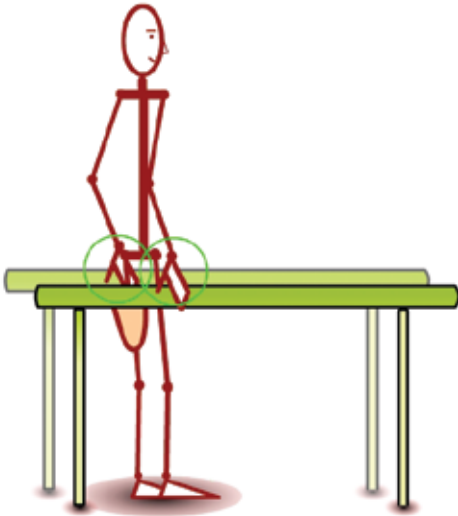

Stand between the parallel bars using both hands to support yourself.

Step 2

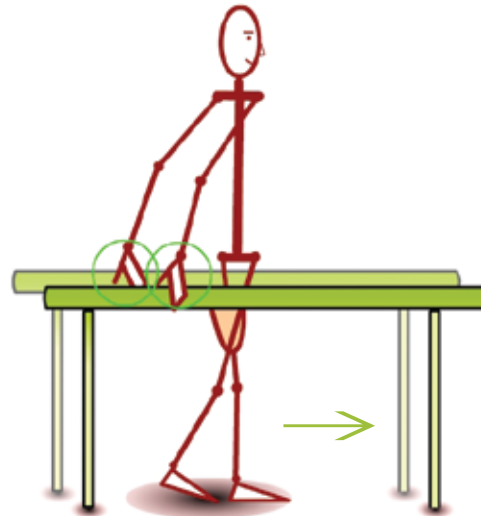

Step forward with the prosthesis, keeping hands parallel to the sound leg.

## 2.7 Prosthetic-leg step backward (two-hand support)

Step 1

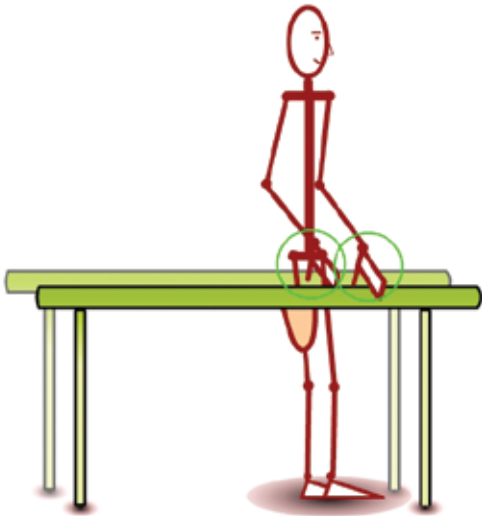

Stand between the parallel bars using both hands to support yourself.

Step 2

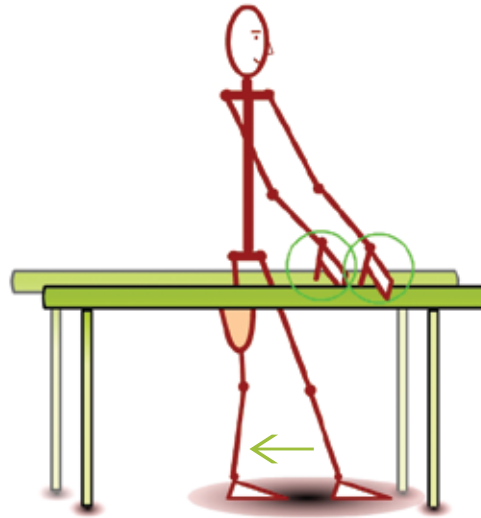

Step backward with the prosthesis, keeping hands parallel to the sound leg.



## 2.8 Prosthetic-leg step through (two-hand support)

Step 1

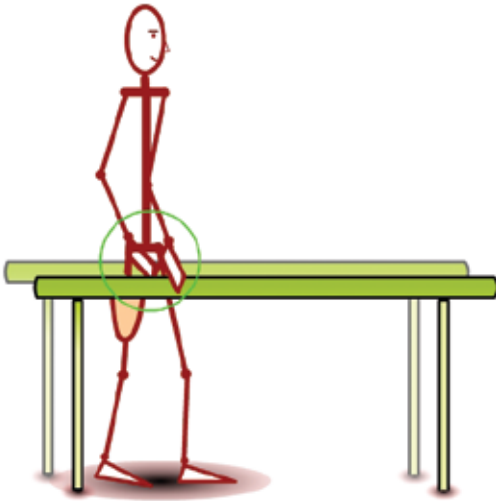

Stand between the parallel bars using both hands to support yourself.

Step 2

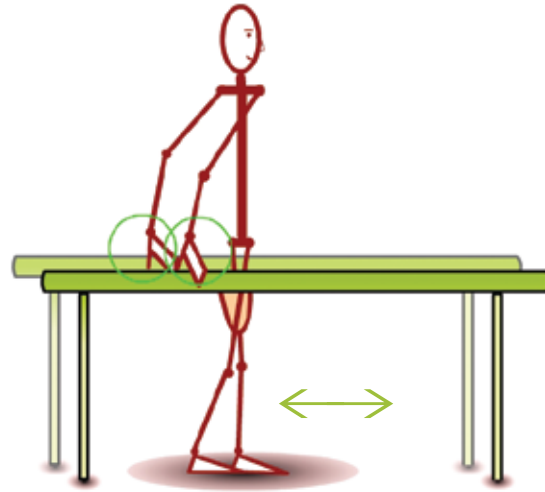

Step forward and backward with the prosthesis, keeping hands parallel to the sound leg and holding the prosthesis slightly in adduction. Maintain an upright position, allowing the trunk and shoulders to move backward and forward, but without lateroflexion.

## 2.9 Prosthetic-leg step forward (one-hand support)

Step 1

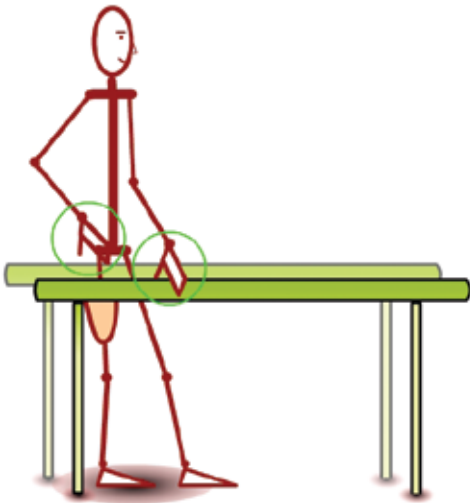

Stand between the parallel bars using one hand to support yourself.

Step 2

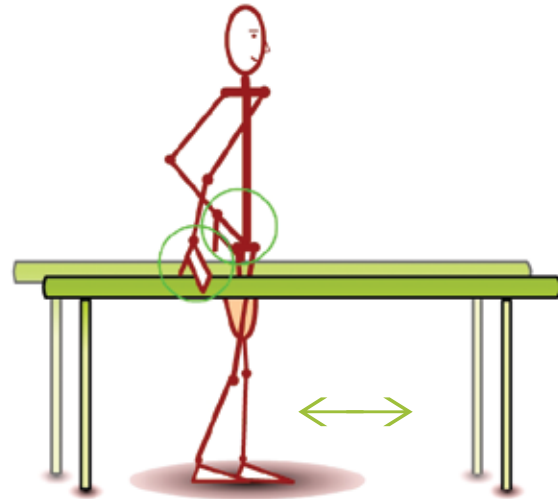

Step forward and backward with the prosthesis. Always use the contralateral hand.

## 2.10 Prosthetic-leg step through (without support)

Step 1

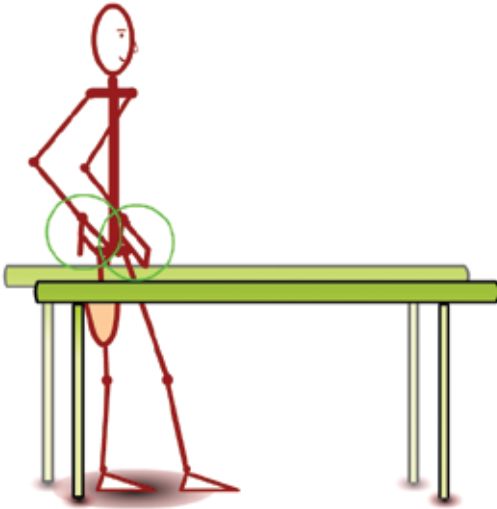

Stand between the parallel bars without support.

Step 2

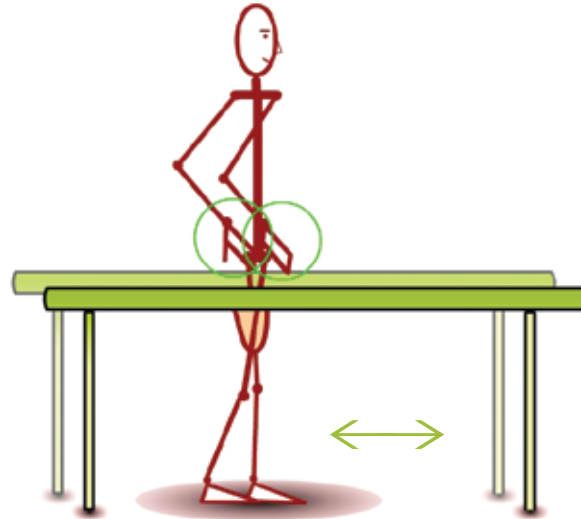

Step forward and backward with the prosthesis.

## 2.11 Walking between the parallel bars (one-hand support)

Step 1

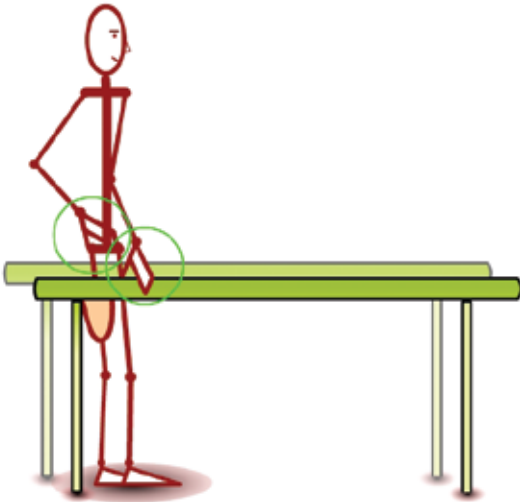

Stand between the parallel bars.

Step 2

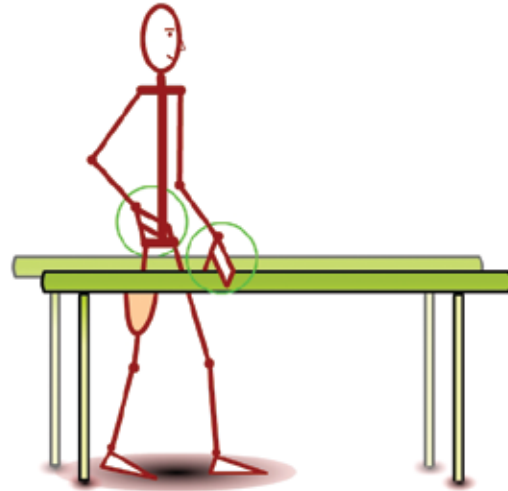

Walk between them using one hand to support yourself. Always use contralateral hand. No lateroflexion of the trunk or uneven step length.

## 2.12 Walking between the parallel bars (without support)

Step 1

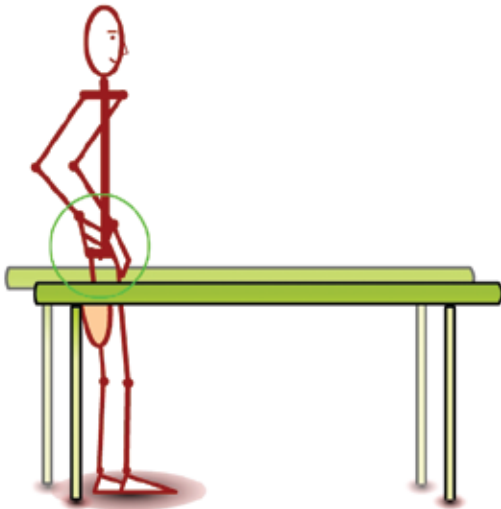

Stand between the parallel bars.

Step 2

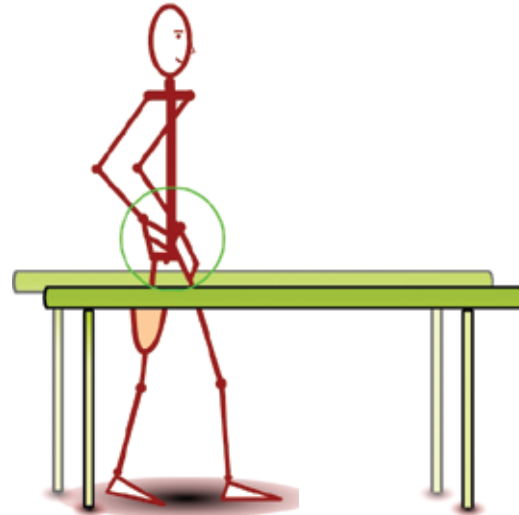

Walk between them without support. No lateroflexion of the trunk or uneven step length.

# Notes

.....

.....

.....

.....

.....

.....

.....

.....

.....

.....

.....

A series of horizontal dotted lines for writing notes.

# ADVANCED EXERCISES



# 3

## ADVANCED EXERCISES

It is important to ensure that the patient performs the exercises accurately, always maintaining the correct posture.

### 3.1 Bouncing a ball (stationary position)

Step 1



Stand in balance on both legs.

Step 2



Bounce a ball on the ground.

## 3.2 Bouncing a ball (walking)

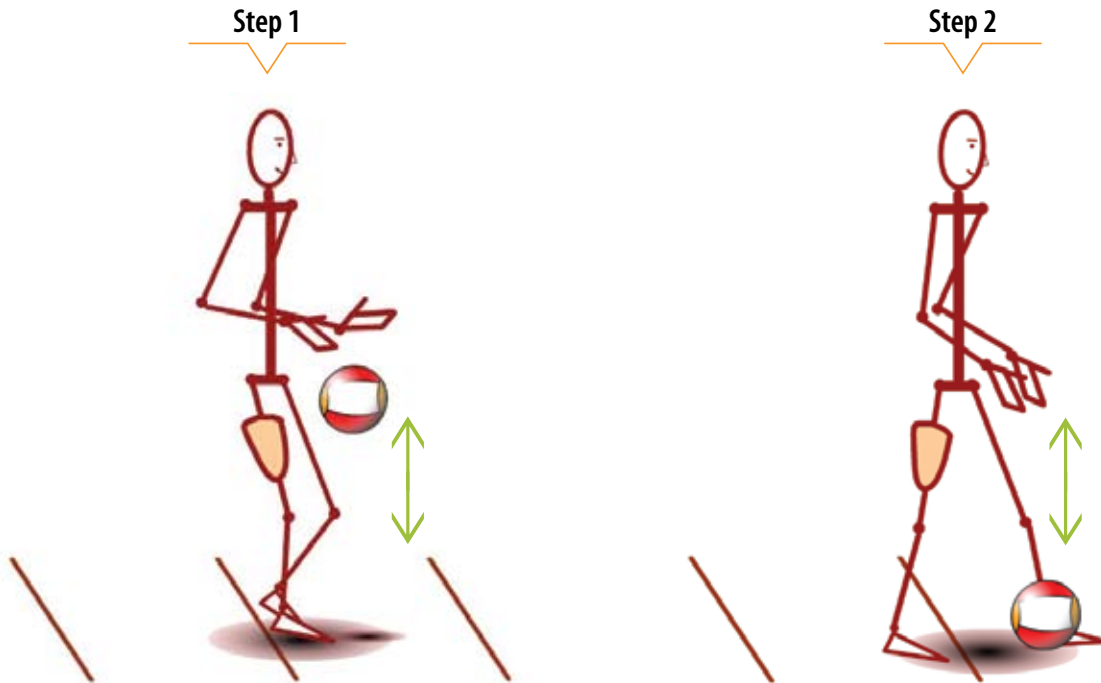

Walk while bouncing a ball on the ground.

### 3.3 Balancing a stick

Step 1

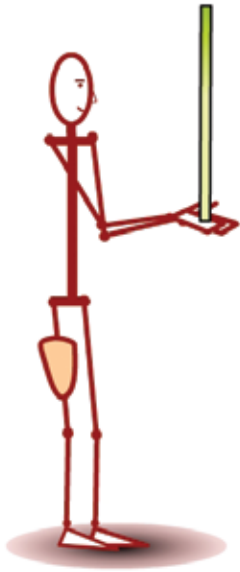

Stand a stick upright on your hand.

Step 2

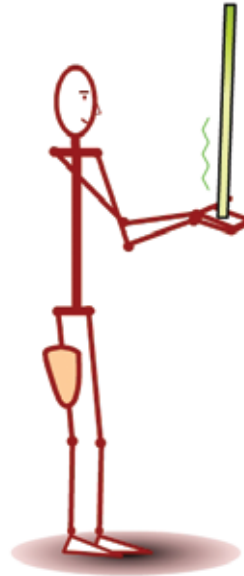

Try to balance it.

## 3.4 Balancing on the prosthesis

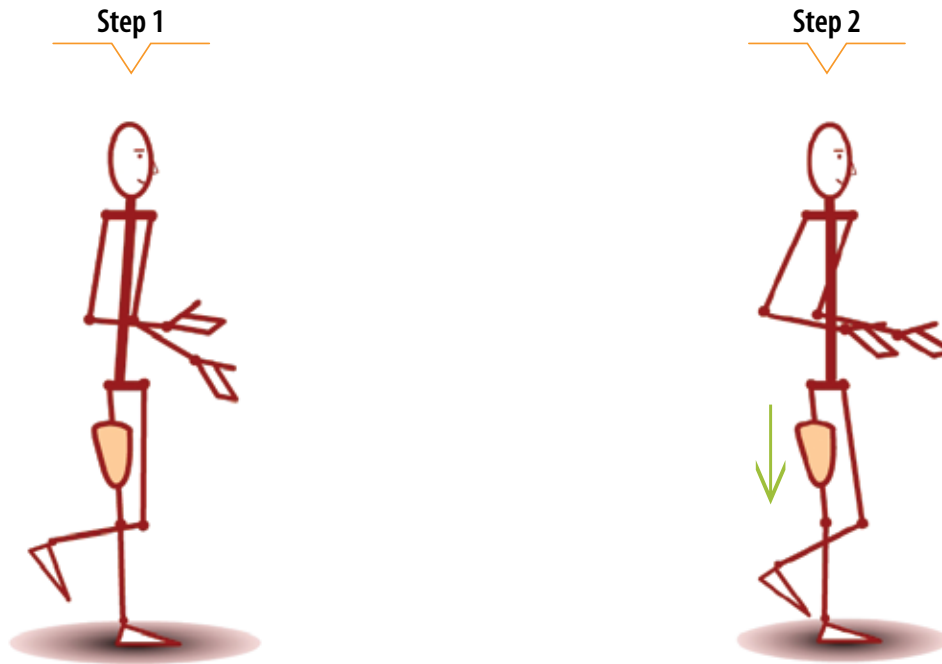

Stand in balance on the prosthesis; flex the sound leg, trying to keep your balance.

# 3.5 Walking on an uneven surface

Step 1



Step 2



Walk on an uneven surface, keeping to a narrow path.

## 3.6 Going up and down a slope

Step 1

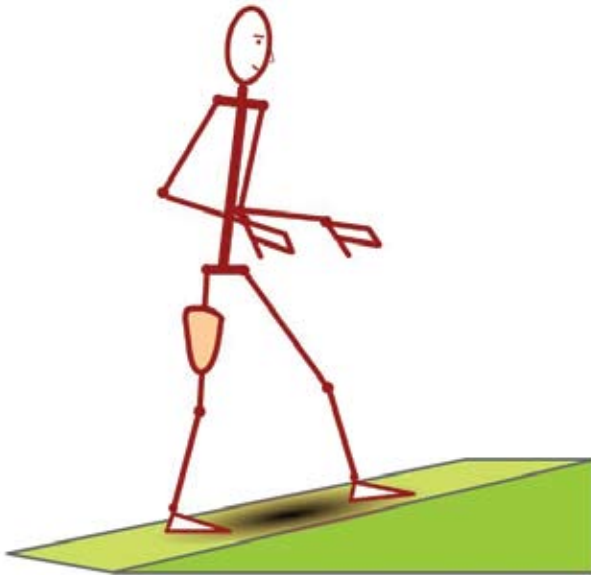

Go up or down a slope.

Step 2

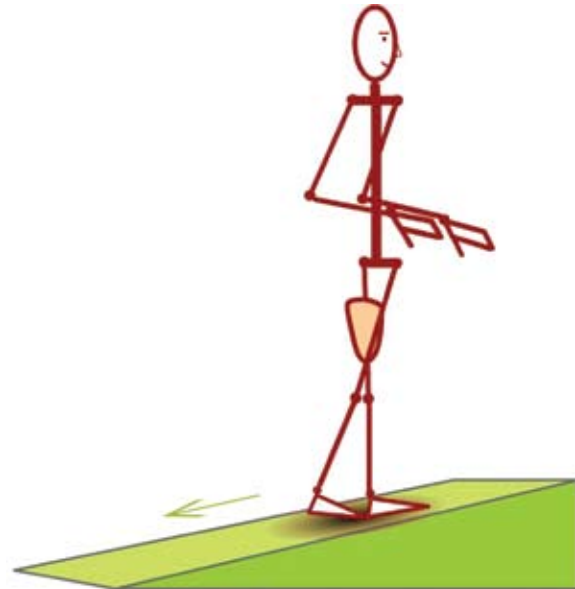

Place the body weight on the prosthesis while doing this.

### 3.7 Jumping (for below-knee amputees only)

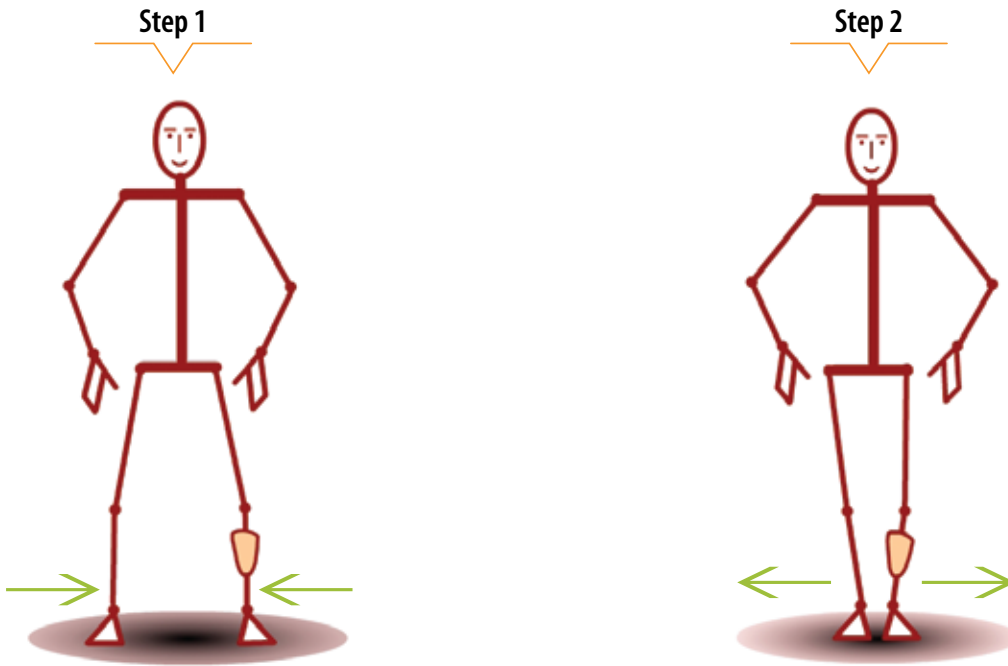

Jump from a spread-leg position to a closed-leg position and back again.



## 3.8 Running

Step 1



Step 2



Place the forefoot of the prosthesis on the ground and stretch the knee, keeping the trunk slightly flexed.

# Notes

A series of ten horizontal dotted lines for writing notes.

.....

.....

.....

.....

.....

.....

.....

.....

.....

.....

.....

.....

.....

.....

.....

# FUNCTIONAL EXERCISES

# 4

## FUNCTIONAL EXERCISES

It is important to ensure that the patient performs the exercises accurately, always maintaining the correct posture.

## 4.1 Rising from a chair

Step 1



Place the sound leg under the chair and flex the trunk.

Step 2



Stand up.

## 4.2 Climbing a staircase

Step 1

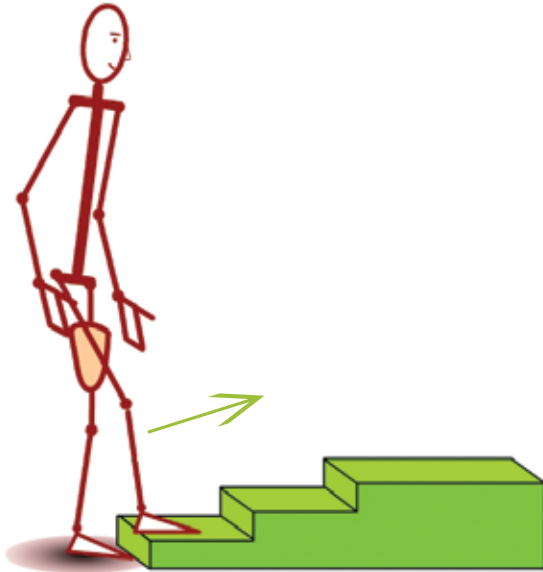

Climb a staircase, starting with the sound leg.

Step 2

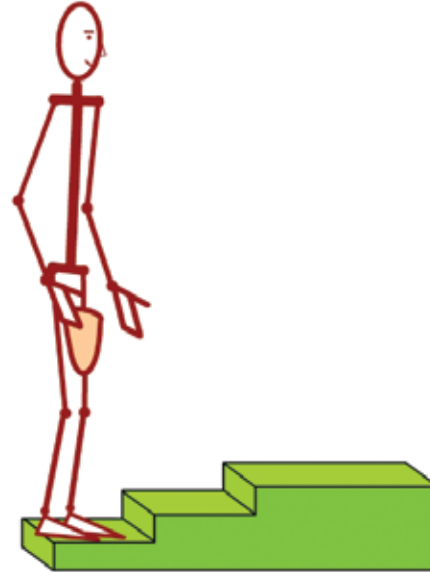

Follow with the prosthesis.

## 4.3.1 Descending a staircase: sound leg step through (for above-knee amputees)

Step 1



Descend a staircase, starting with the prosthesis.

Step 2



Follow with the sound leg, which comes to rest next to the prosthesis.



## 4.3.2 Descending a staircase: sound leg step through (for below-knee amputees)

Step 1

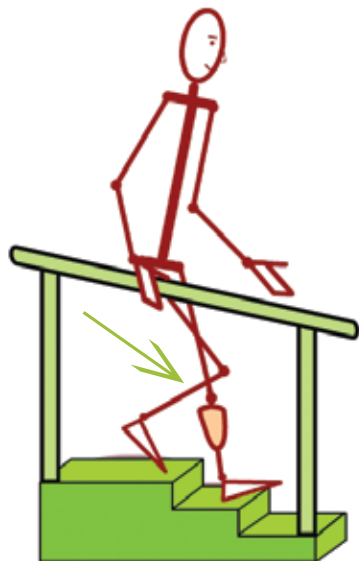

Descend a staircase, placing the heel of the prosthesis on the edge of the first step down.

Step 2

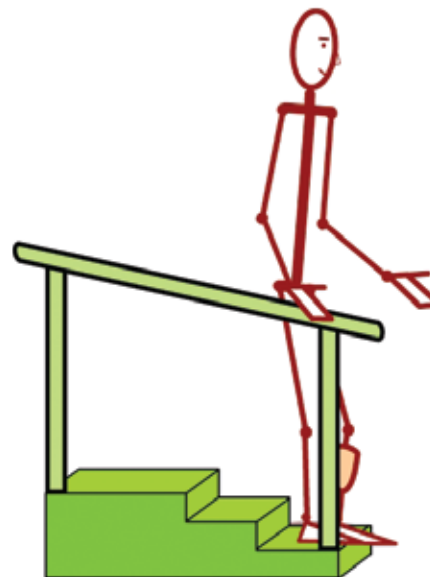

Step through onto the next step with the sound leg which comes to rest next to the prosthesis .

## 4.4.1 Sitting down and getting up from the floor (method 1: forward)

Step 1

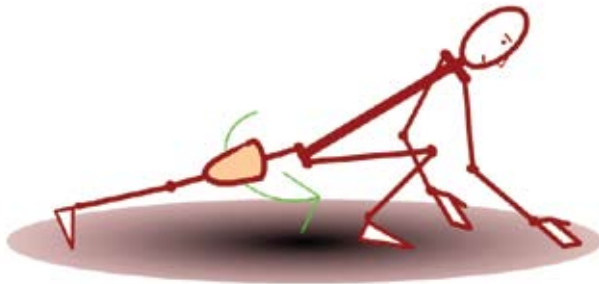

Place the prosthesis in retroflexion, abduction and external rotation.

Step 2



Bend the trunk and support yourself on both hands and one knee; turn and sit down. Do the reverse for getting up.

## 4.4.2 Sitting down and getting up from the floor (method 2: backward)

Step 1



Move the prosthesis forward.

Step 2



Bend the knee and support yourself on both hands; sit down. Do the reverse for getting up.

## 4.5 Sitting down on a chair (for bilateral amputees)

Step 1



Face the chair and place one hand on the seat of the chair and the other on the back.

Step 2

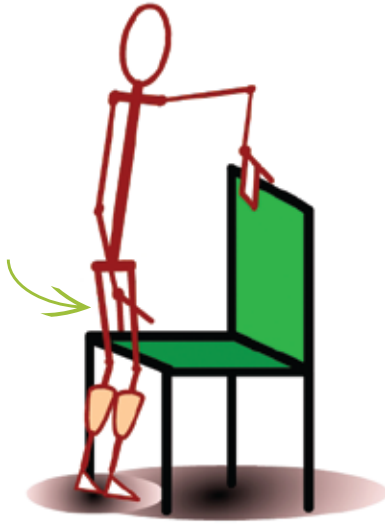

Turn your body and flex your legs.

Step 3



Sit down and do the reverse for getting up.

## 4.6 Lying down (for bilateral amputees)

Step 1



Place both hands on the floor.

Step 2

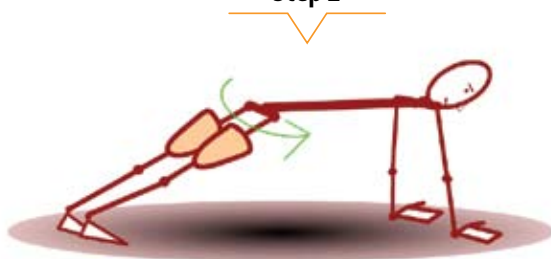

Increase the distance between hands and feet.

Step 3



Turn around, sit down and lie down using the elbow.

## 4.7 Getting up from the floor (for bilateral amputees)

Step 1

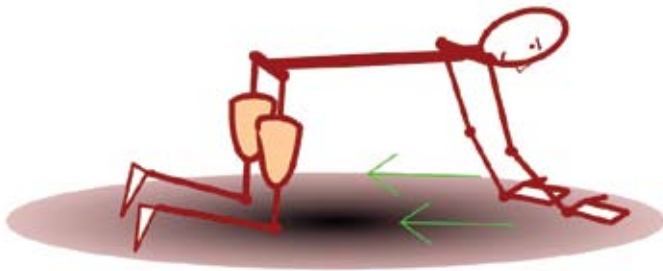

Come to a sitting position; turn around and support yourself on your hands and knees.

Step 2

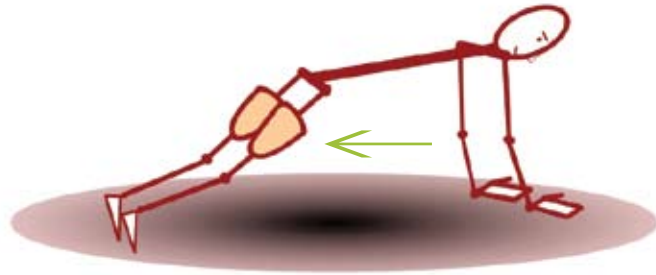

Stretch one prosthesis backward and outward; shift the body weight to the stretched prosthesis and both arms; stretch the other prosthesis; decrease the distance between hands and feet and stand up.

# 4.8 Weight carrying

Step 1



Step 2



Walk carrying a weight on the prosthetic side.

# Notes

A series of ten horizontal dotted lines for writing notes.



.....

.....

.....

.....

.....

.....

.....

.....

.....

.....

.....

.....

.....

.....

.....

.....

.....

.....

.....

.....

.....

.....

.....

This CD ROM/booklet is based on an internal ICRC document produced in 1990 by Theo Verhoeff.

**The team: International Committee of the Red Cross (ICRC)**

Theo Verhoeff, PT, MPH

Barbara Rau, PT, MPTSc

François Friedel, PT

**Deutsche Gesellschaft für Technische Zusammenarbeit (GTZ)**

Heinz Trebbin, Project Manager

**University Don Bosco, El Salvador**

Gilberto Meléndez, Designer and Animator

Hector Rodríguez, Animator

**Bibliography:** Engstrom B., Van de Ven C.  
*Therapy for Amputees*, Churchill Livingstone, London, 1999

## **MISSION**

The International Committee of the Red Cross (ICRC) is an impartial, neutral and independent organization whose exclusively humanitarian mission is to protect the lives and dignity of victims of armed conflict and other situations of violence and to provide them with assistance.

The ICRC also endeavours to prevent suffering by promoting and strengthening humanitarian law and universal humanitarian principles.

Established in 1863, the ICRC is at the origin of the Geneva Conventions and the International Red Cross and Red Crescent Movement. It directs and coordinates the international activities conducted by the Movement in armed conflicts and other situations of violence.

For further information, visit  
[www.icrc.org](http://www.icrc.org)



**ICRC**

International Committee of the Red Cross  
19, avenue de la Paix  
1202 Geneva, Switzerland  
T + 41 22 734 60 01 F + 41 22 733 20 57  
E-mail: [shop@icrc.org](mailto:shop@icrc.org)  
[www.icrc.org](http://www.icrc.org)  
© ICRC, September 2008