

GWI WEST AFRICA

**A PRACTICAL GUIDE FOR BUILDING A SIMPLE PIT LATRINE**

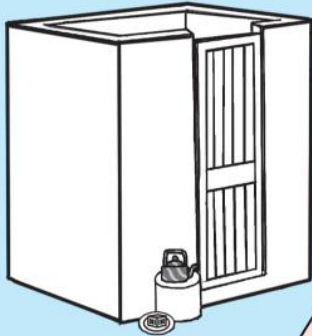

**How to build your latrine  
and use it hygienically,**



**for the dignity,  
health, and well being of  
your family.**

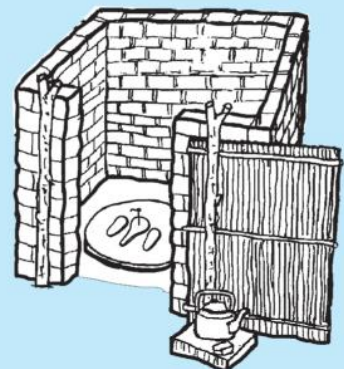
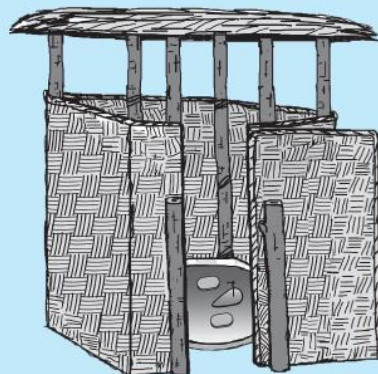
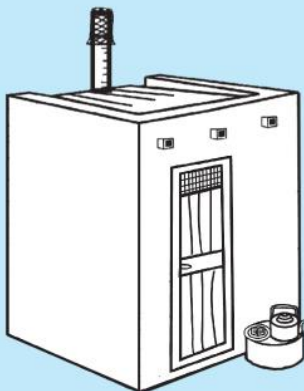
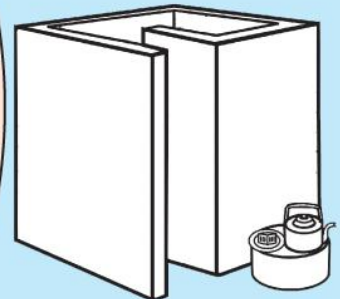
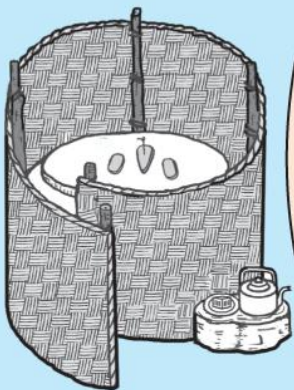

# Foreword

## How to use this Guide

This latrine manual has been designed for use as a technical guide at individual household level to assist those families who have already decided to build their own latrine. This step-by-step guide to basic latrine construction is a vital follow-on from activities that 'trigger' sanitation awareness in the village and mobilize individual households to improve sanitation in their own home and village. Such 'triggering' activities may include Community Led Total Sanitation (CLTS) and Participatory Hygiene And Sanitation Transformation (PHAST) or other participatory approaches.

The dialogue in this guide should be acted out by a facilitation team in the form of a skit and followed by a debate. At the end of each key step (siting the latrine, digging the pit, making the slab, building the superstructure) the skit should be paused to allow debate with the public and respond to questions and comments on that particular step. This is necessary to clarify any technical questions the community may have. The skit can be acted out in the yard of a family planning to construct a latrine. This allows the skit to be played out in an environment that the 'audience' will recognize as their own.

This booklet is then given to those families present at the skit/dialogue who have already taken the firm decision to build their own latrine. A strong, appropriate, and low-cost, well-sited latrine guarantees user safety, minimizes smell and flies, and offers a convenient place for the privacy and hygiene needs of all family members. The quality of construction of such a household latrine is the best way to satisfy the users and ensure a definitive end to open defecation!

Not intended for mass distribution, this guide has been designed as a personal and practical do-it-yourself guide for use at individual rural household level in West Africa. We encourage you to use it, translate it and reproduce it on the condition that you do so for development purposes alone and on a not-for-profit basis. We welcome any feed-back on its usefulness and content so that we can improve any further editions.

We can be reached by e-mail: [lambert.nikiema@crs.org](mailto:lambert.nikiema@crs.org) or [gwiprojects@iied.org](mailto:gwiprojects@iied.org)

## Acknowledgements

This guide was produced as a team effort by the Hardware Quality Project, in the West Africa cluster of the Global Water Initiative (GWI) with the generous support of the H.G. Buffett Foundation:

<http://www.globalwaterinitiative.com>

The Regional GWI West Africa programme operates in five West African countries: Burkina Faso, Ghana, Mali, Niger and Senegal. The consortium of partner organizations involved in the programme are:

- International Union for the Conservation of Nature (IUCN)
- Catholic Relief Services (CRS)
- CARE International
- SOS Sahel International (UK)
- International Institute for Environment and Development (IIED).

The main authors are Lambert Zounogo P. NIKIEMA (CRS), Sue CAVANNA (Sahel Consulting), and Jean-Philippe DEBUS (CRS).

Key contributions were made by colleagues whose names appear on the back cover.

We would like to thank WaterAid and CREPA for their contribution.

Illustrations: BONKOUNGOU Y. Parfait, Ouagadougou, Burkina Faso.

June 2011

# Why build a latrine?

## Laurent and his family give their reasons.

It is difficult to have to go far to defecate, particularly when sick.



When I have a visitor at home, I am embarrassed to have no latrine for him to use.

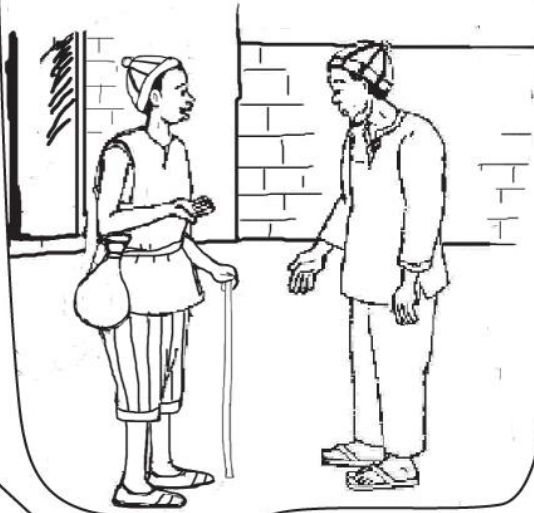

It is shameful when someone sees you relieving oneself, and you could also be assaulted.

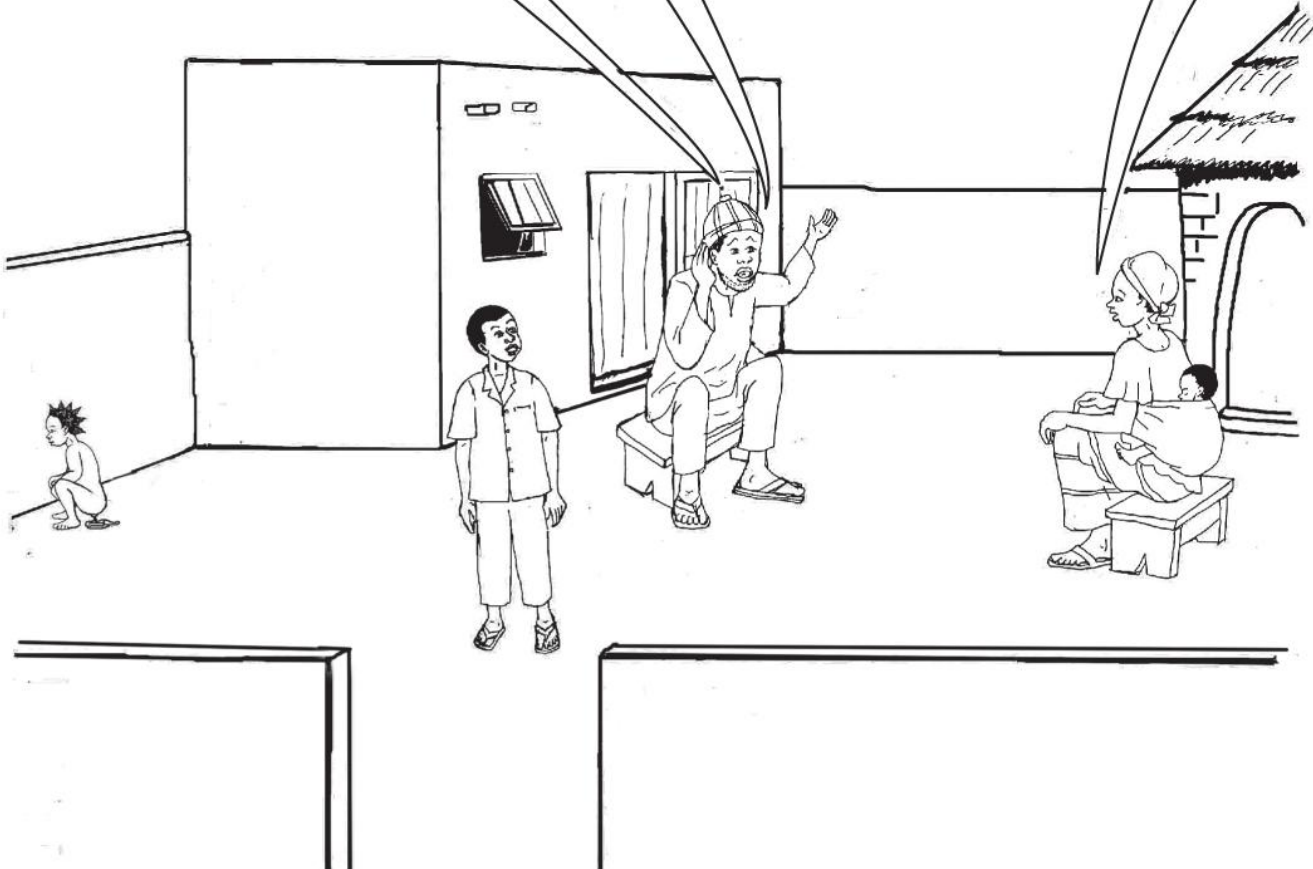

Having talked to his family and considered the difficulties they encounter when they need to defecate, Laurent (the man) decides to build a latrine. He then gets information from Moussa, who has already constructed a latrine.

# Where will I build my latrine?

Moussa, I want to build a latrine for my family like you have done. But I don't know how to do it. Can you help me?

Laurent, you have done well to ask me because where and how you build it are very important. Listen carefully to what I am going to say.



The latrine must be located in a place where its odours can't reach the house or the kitchen.

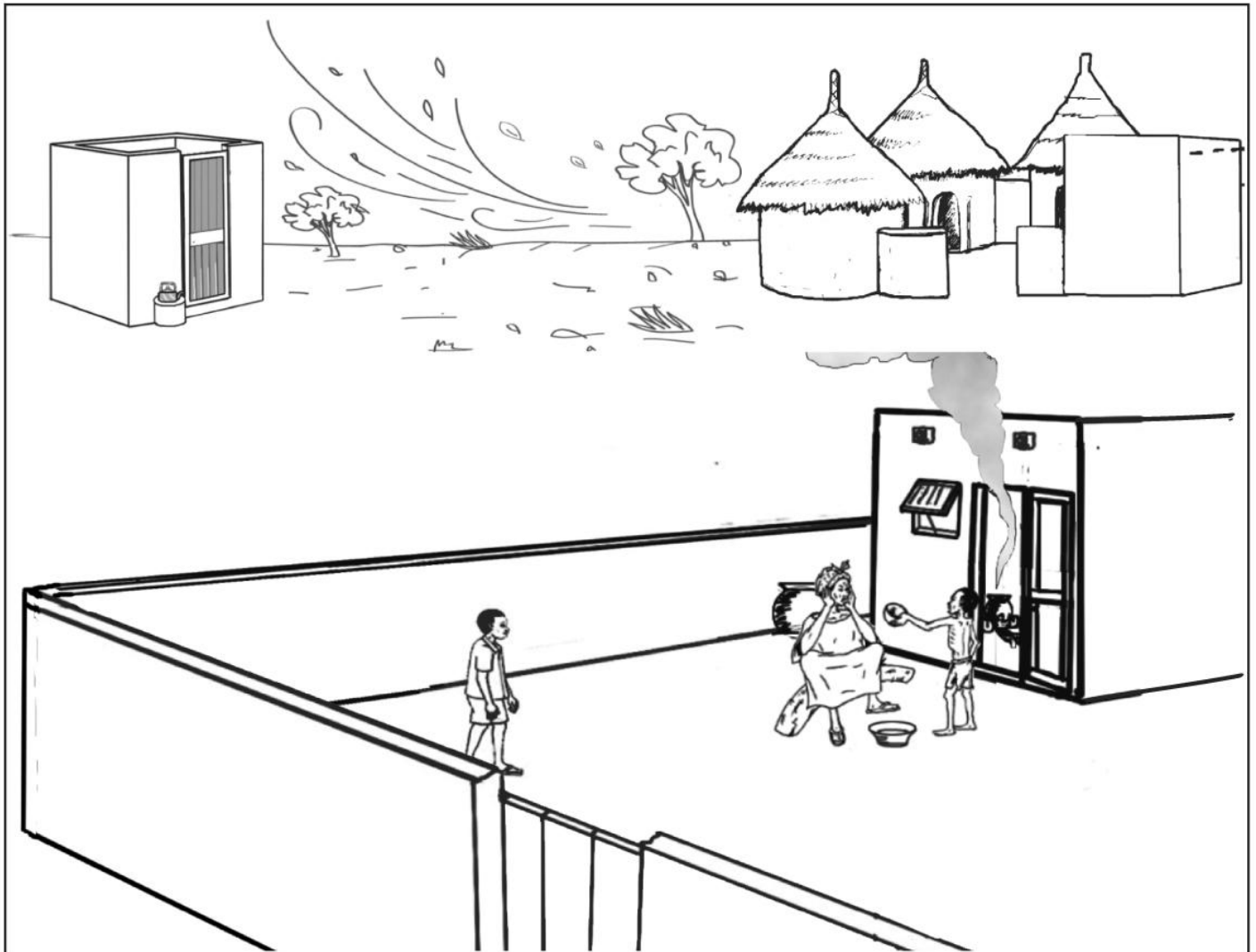

The latrine must not be located in a place that can flood.



The latrine must be placed at a least 30 m from a well and about 6m from a kitchen.

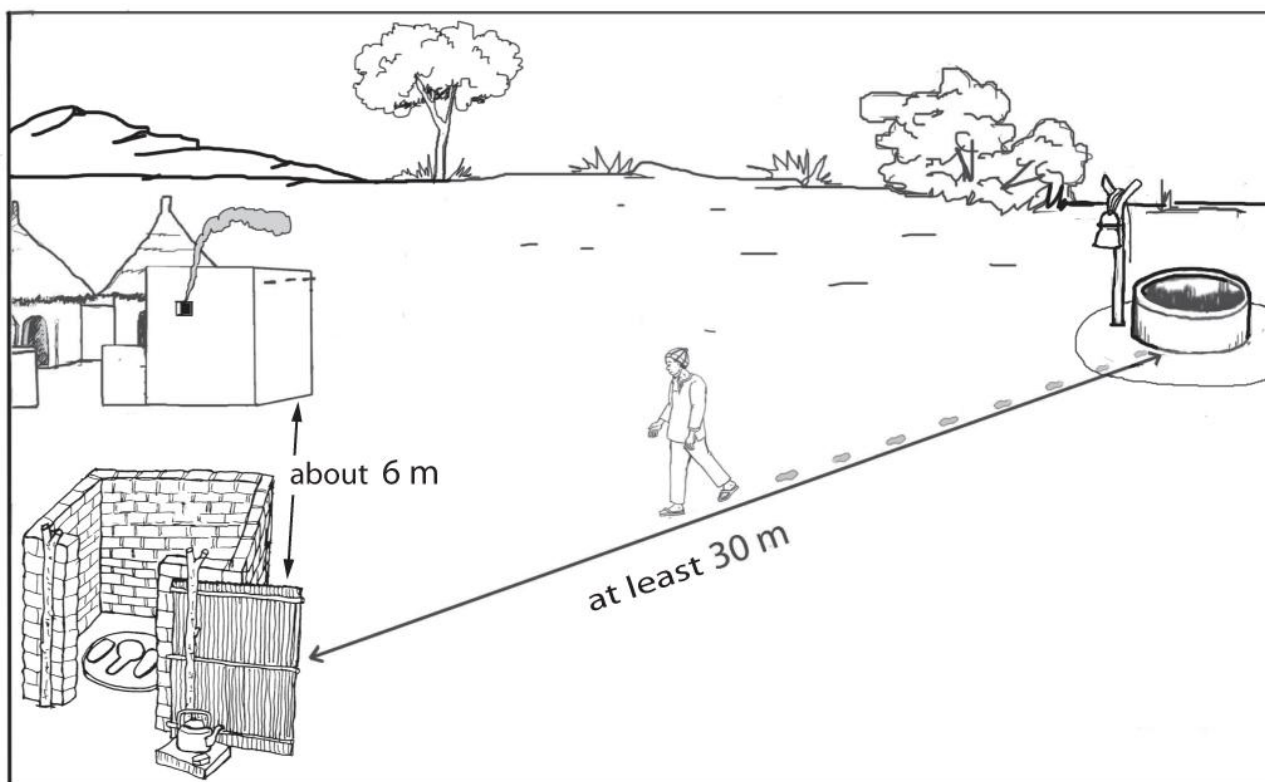

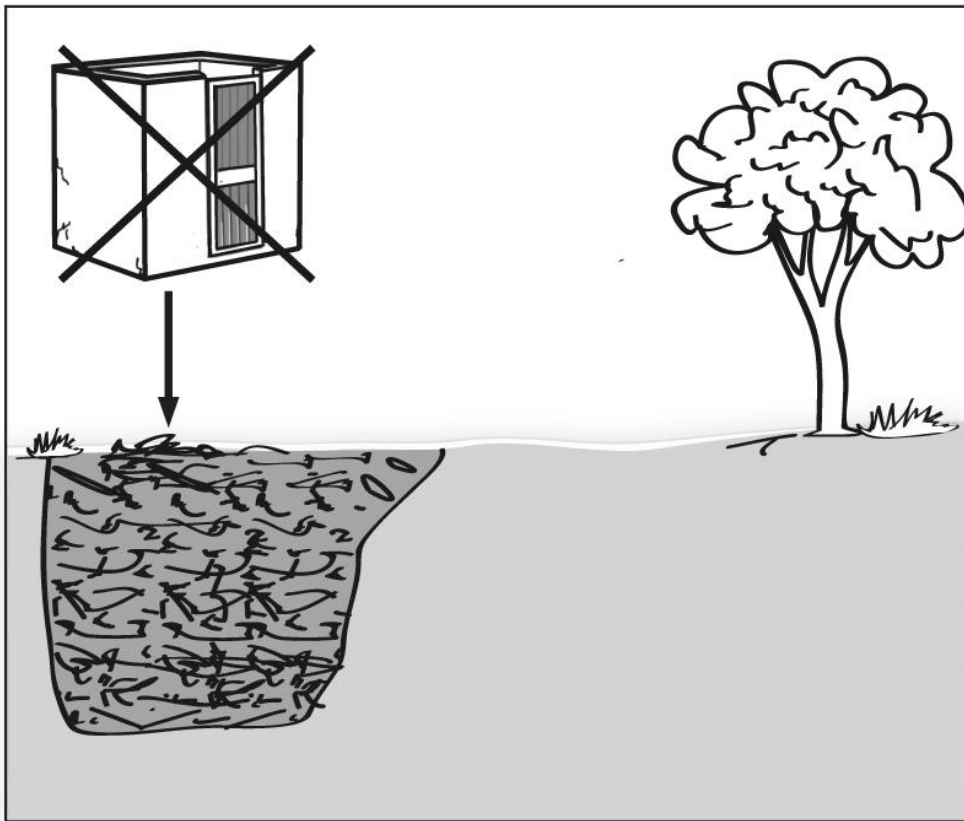

The latrine must not be dug in the same place or next to an old latrine.



The bottom of the pit of the latrine must be at least 2 m above the water table (highest level of the water in the wells at the end of the rainy season) to avoid polluting the water source.

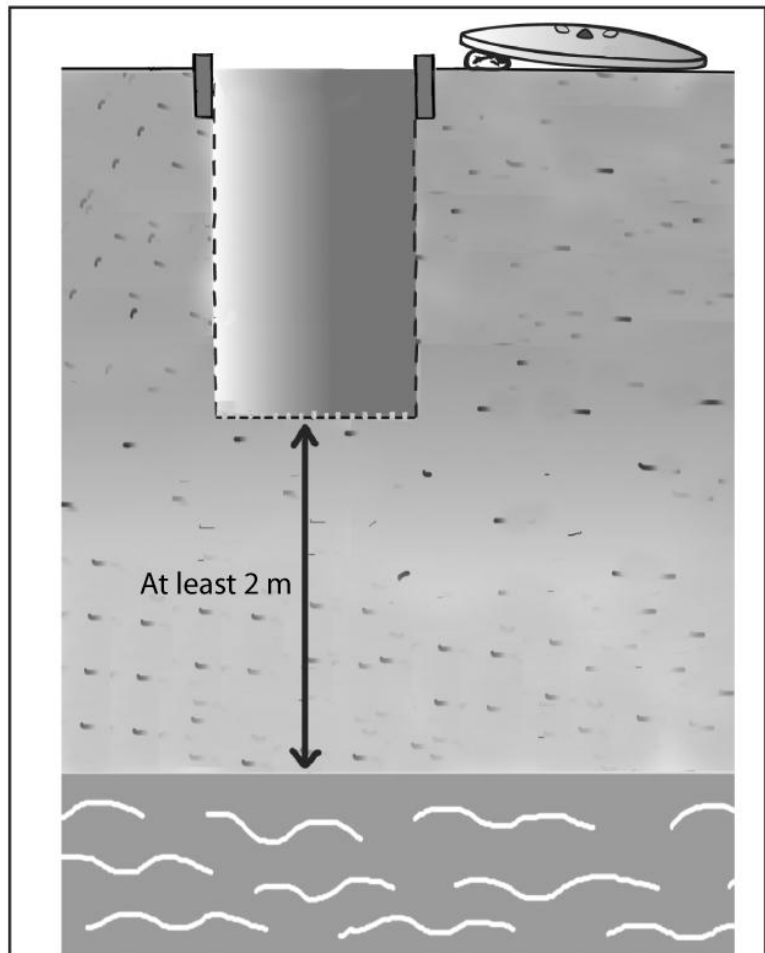
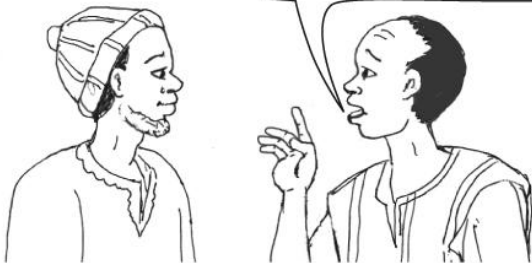

# How to dig the pit ?

I have followed your advice and have chosen a good place for the latrine. But how do I dig the hole?

The shape, the size and the depth of the pit are important.

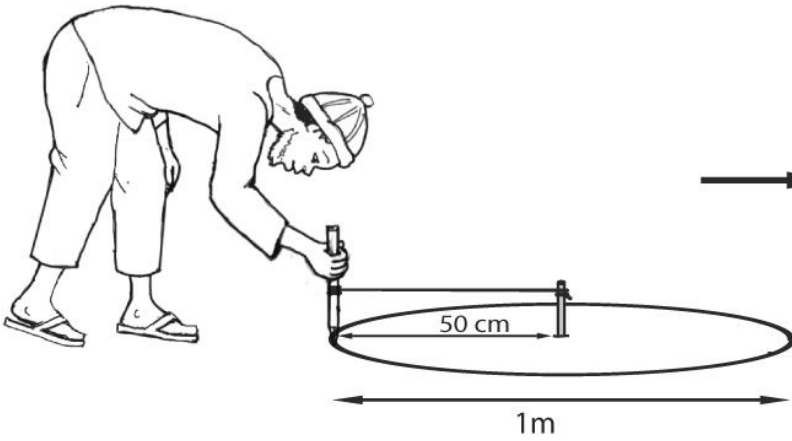

It is better to dig a circular hole (the walls will be stable).

For a traditional latrine, the wood must overlap the pit hole by at least 30 cm on each side.

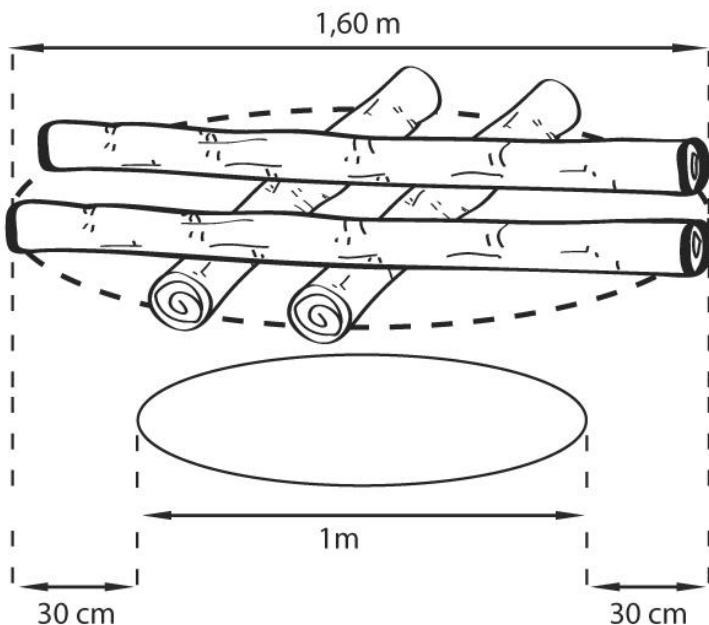

For a concrete slab, the diameter of the slab must overlap the pit hole by 10 cm on each side.

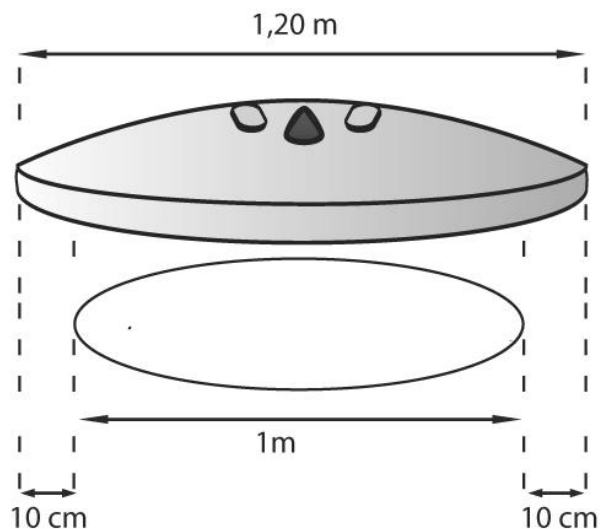

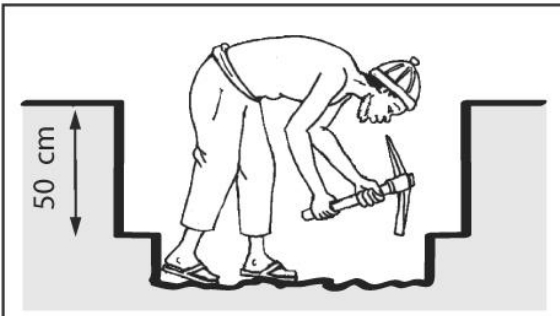

If possible, the depth of the pit must be at least 2 m.

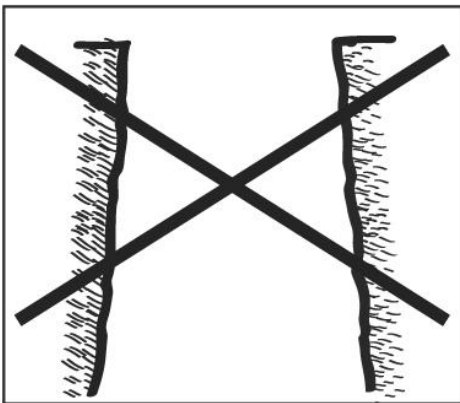
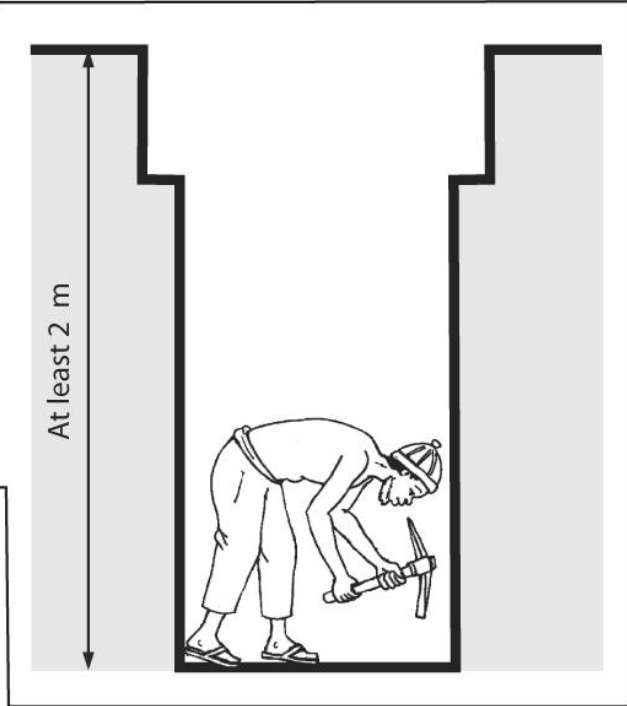
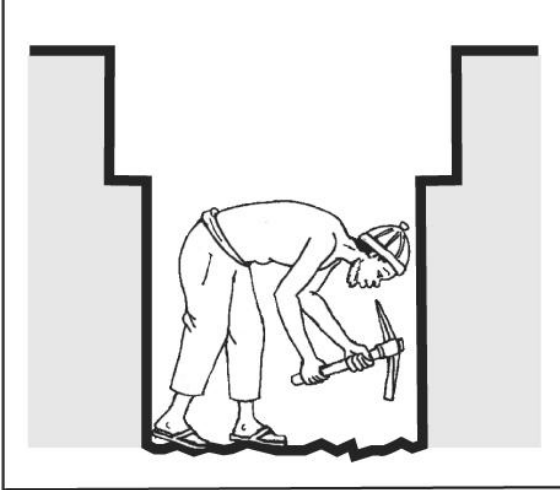

The diameter of the pit must be uniform throughout and the walls must be vertical.

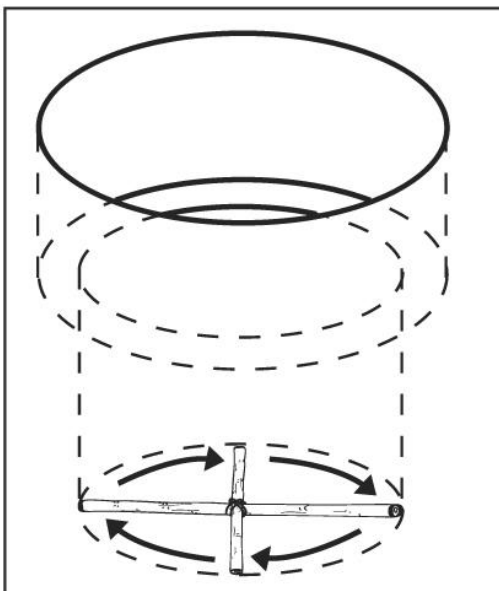

To avoid this kind of situation a simple tool can be used every 50 cm when deepening the pit to assure that an even diameter of the pit is maintained. This simple tool can easily be made of two pieces of wood, each wood to be exactly as long as the diameter of the hole and fastened at 90° at the centre.



# Reinforcing the walls of the pit in stable soils

Moussa, do you know why Oussemi's latrine collapsed? I fear that the same thing will happen to me. What should I do?



You must make a sub-foundation and line the top of the pit if the walls are unstable.

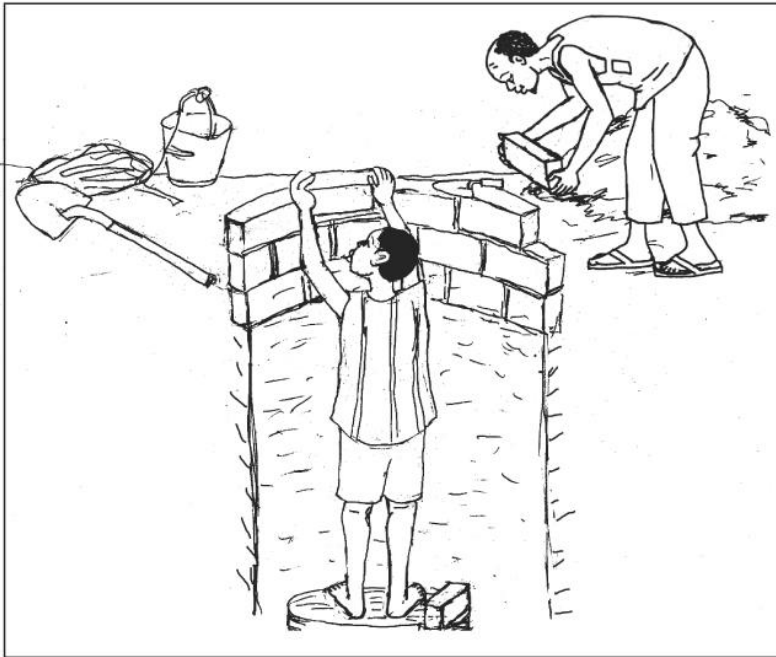

Whatever type of soil you have, the sub foundation at the top 50 cm of the pit must be lined with concrete bricks or with rubble stones.



The pit lining must be built above ground level to at least one line of concrete bricks or rubble stones.

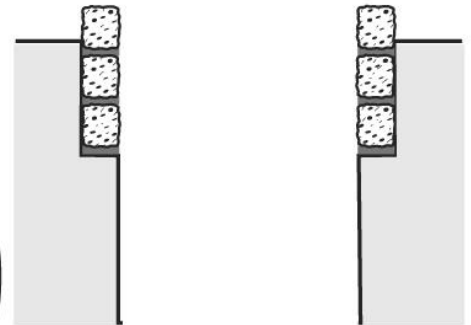

If you are using concrete bricks, you need around 24 bricks for the top 50 cm and the above ground level part.

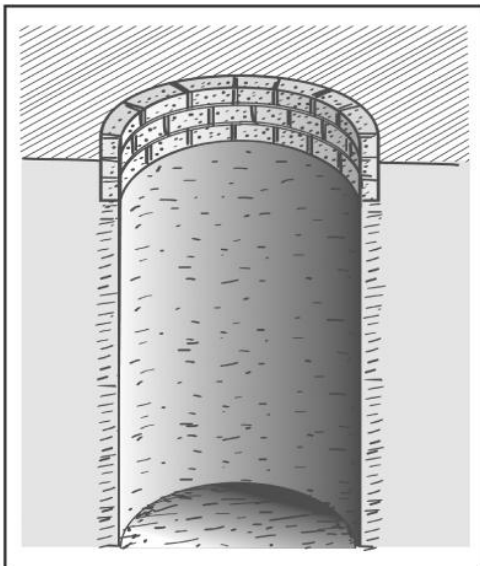

In an area where the soil is stable, it is not necessary to line the whole pit. Only the top 50 cm will be lined.



# Reinforcing the walls of the pit in unstable soils

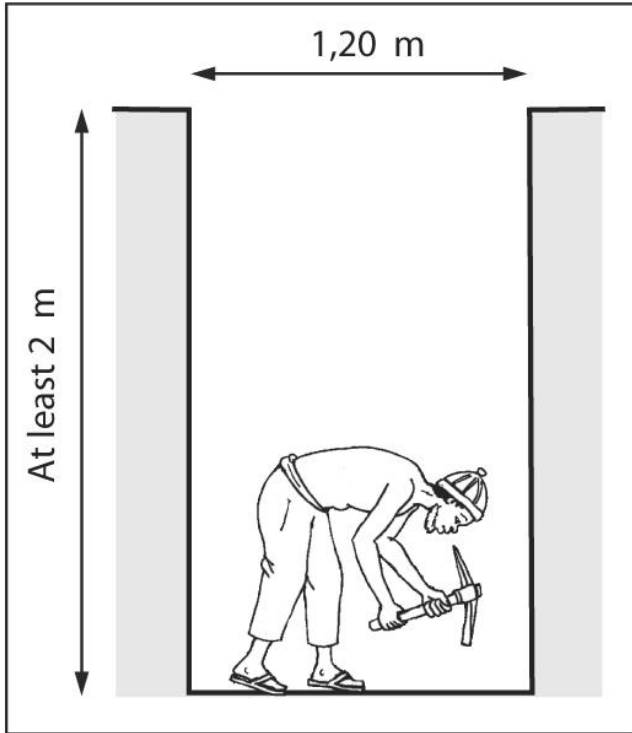

If the soil is unstable, the diameter of the pit must be uniform throughout its entire depth and will be of the same diameter as the slab (1.20m)

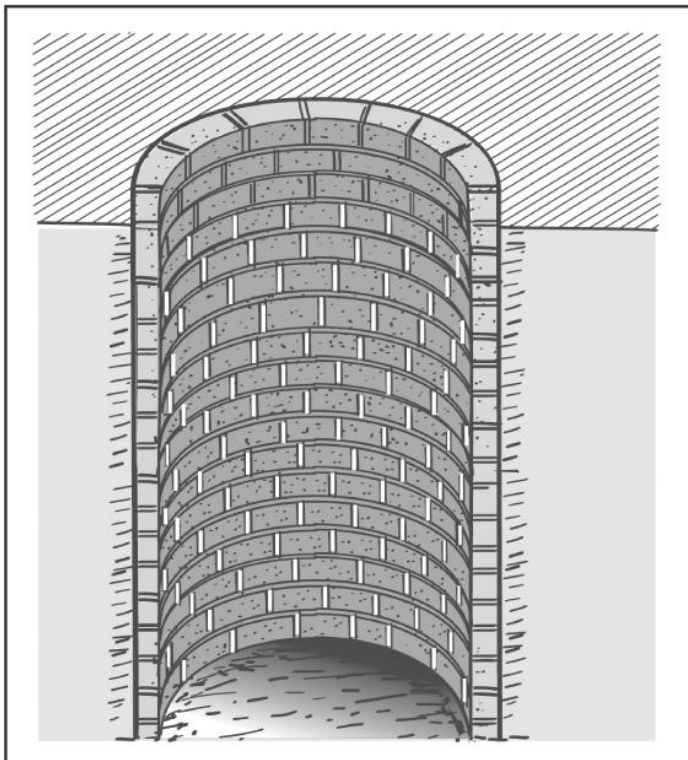

The whole pit will be lined with concrete bricks or rubble stones. You will need 24 bricks for the top 50 cm (and the above ground level part), and 33 bricks for each meter of the rest of the pit.



But the vertical joints between the concrete bricks/rubble stones of the walls below the top 50 cm must not be filled in.

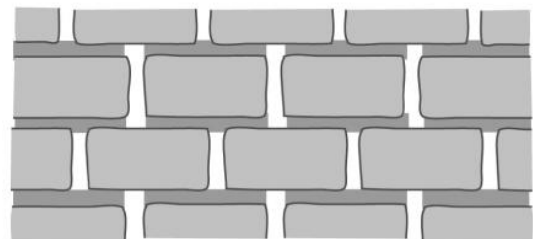

# How do I make the concrete bricks?



The stability of the pit walls depend on the quality of the materials used to line the pit.

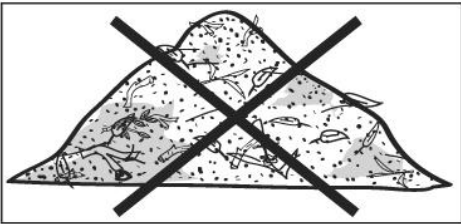

The sand must be clean (not contain wood, leaves, dirt etc.) and must not be too fine.



You must not use cement that is old and lumpy, that has been damaged by water or is in opened sacks.

With 1 bag of 50kg of cement, 4 wheelbarrows of sand and around 40 liters of water you can make 25 to 30 concrete bricks of 15 cm each or 40 to 45 concrete bricks of 10 cm each.

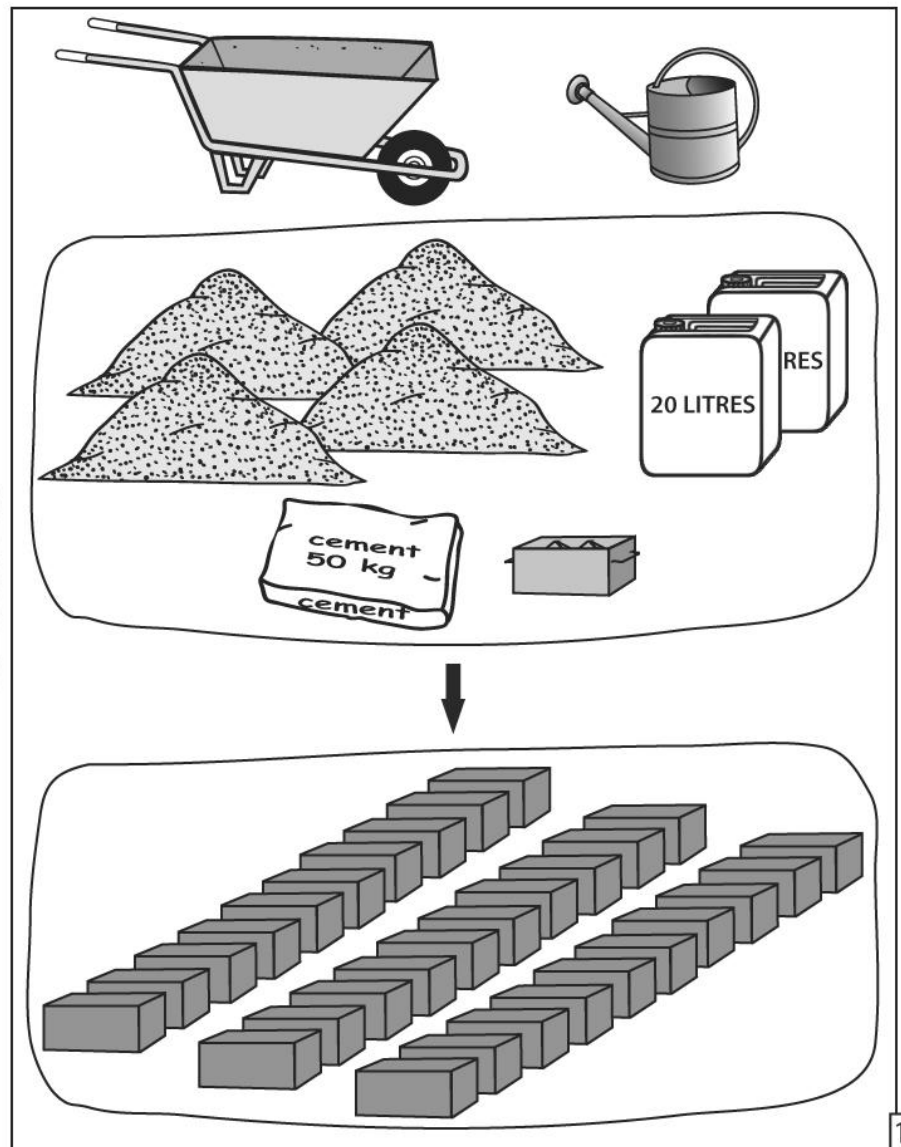

The concrete bricks must be prepared under shade.



The sand and the cement must be well mixed: you must mix them until both have a uniform colour.

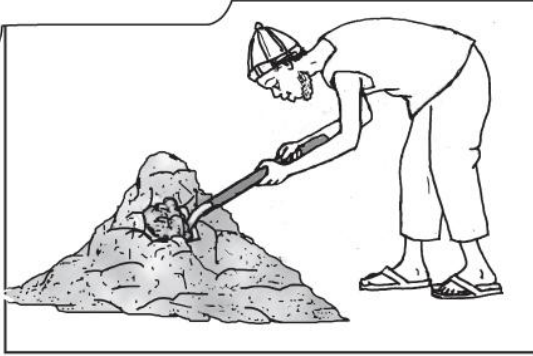

Morning

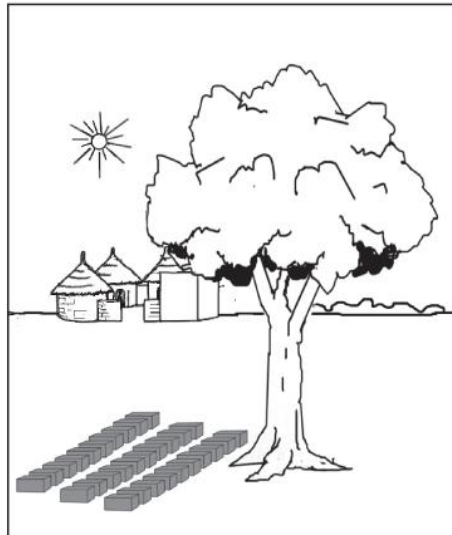
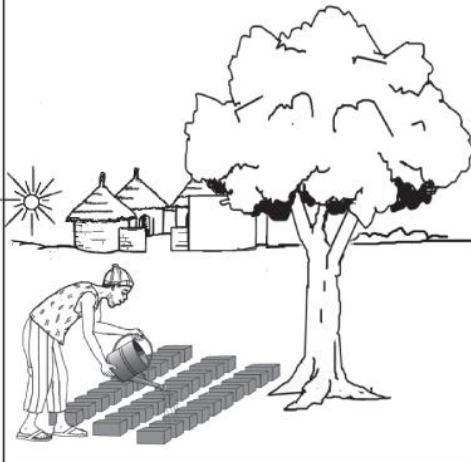

Evening

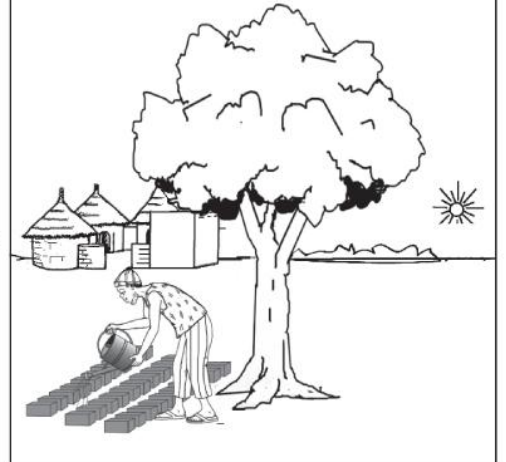

You must start watering the concrete bricks the day after you make them, and then 2 times a day (in the morning and in the evening) for the next 2 weeks.



The concrete blocks can be used from 21 days after their preparation.

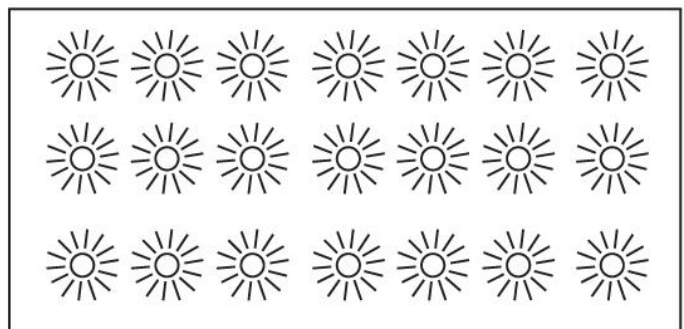

# Checking the quality of the slab

Can I use the dome shaped slab? It is not expensive but I fear it may not be strong enough.



There are many types of slabs that you can use. The one you are talking about is not very expensive but is very strong. You need 25 kg of cement, 6 meters of iron (diameter 6mm), one wheelbarrow of sand, and one wheelbarrow of gravel to make one slab.

But you must test the strength of the slab in order to be sure that it has been made well.

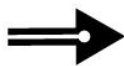
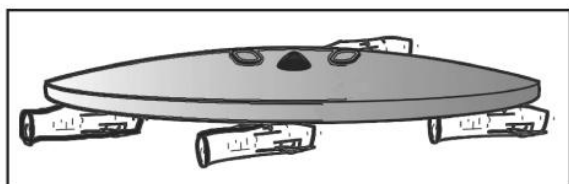

To test the slab, you have to place it on 4 wood supports.

5 or 6 persons must stand on it at the same moment.  
The slab will not break if it has been well made.

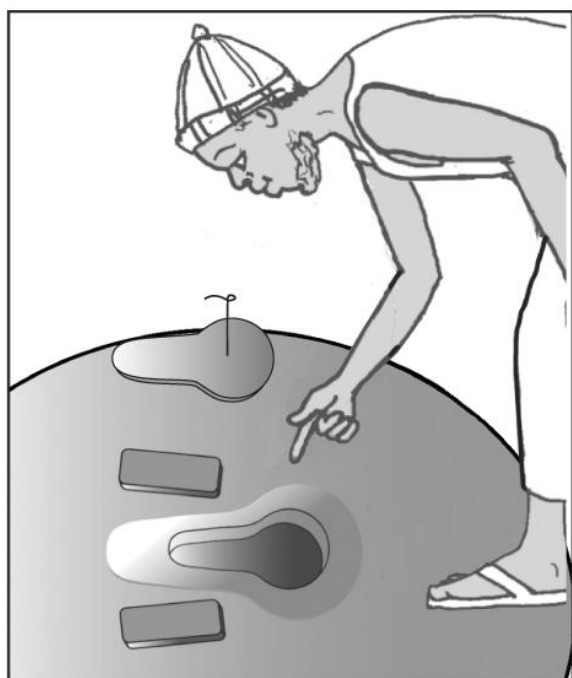

You can either buy the slab ready-made or have it made by a local mason. The slab must have these characteristics:

- ← The sides of the hole must be very smooth so that cleaning the slab will be easy;
- ← The area around the hole must be sloped to allow the waste water to flow towards the hole;
- ← The size of the hole must not be too big so that small kids can not fall into it;
- ← The biggest part of the hole must not exceed 15 cm in diameter .

# Installing the concrete slab

The mortar used to join the slab onto the foundation must not be very rich, in order to allow removal of the slab when necessary.

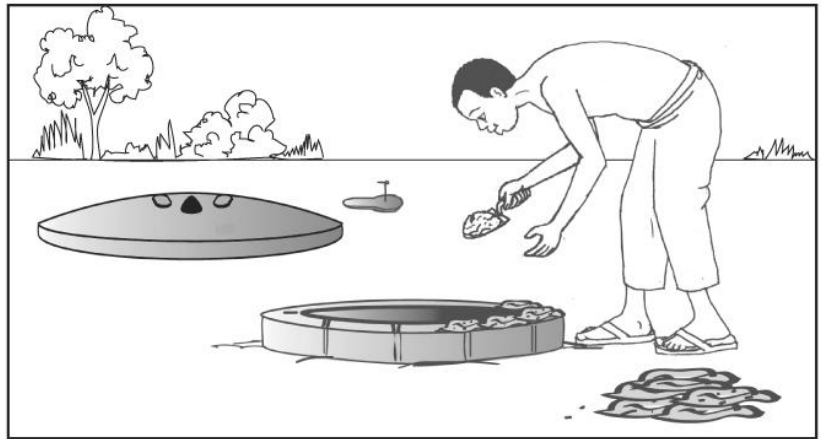

The slab must be well centred and well seated on the sub foundation.



You must earth up the soil around the sub foundation to avoid stagnant water accumulating around the latrine.

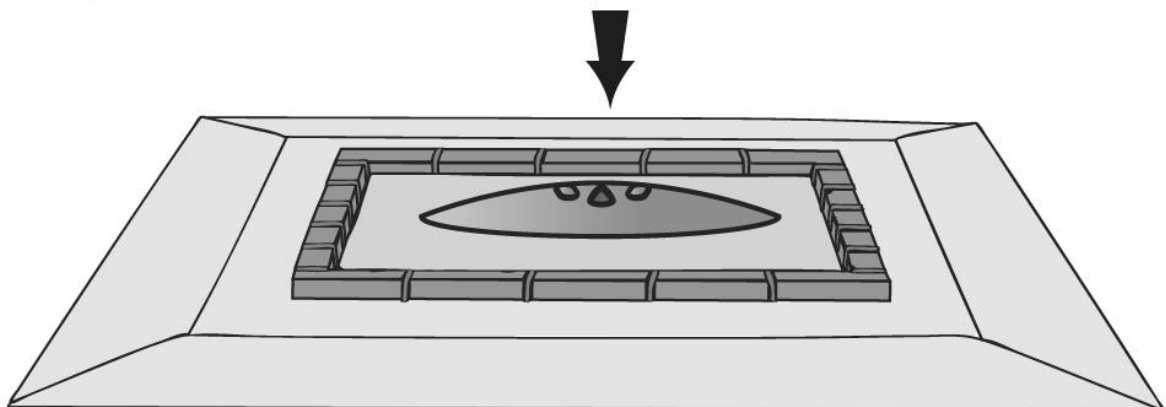
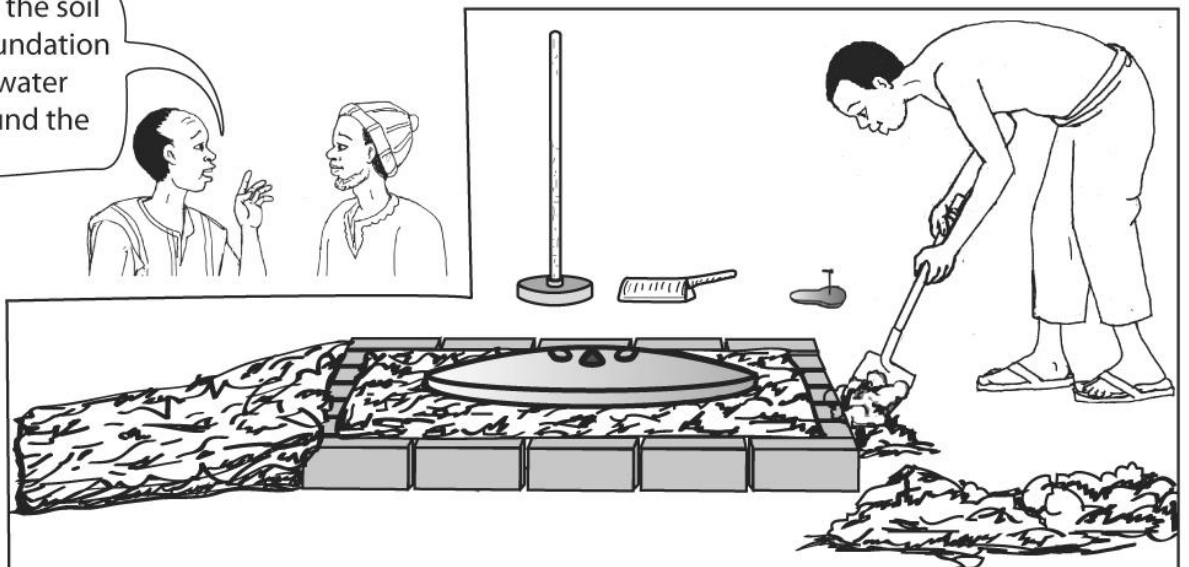

# Making a traditional slab

Are there other cheaper options for those who don't really have means to make a concrete slab?



Yes, for example my cousin Harouna, before being able to afford a concrete slab, has made a traditional slab. But this type of slab must be built in a particular way.

You must use 2 big logs about 15 cm apart, that can support the weight of the slab plus the weight of the user. If the pit is not lined, these logs must be long enough to rest on the soil well beyond the limit of the pit, 30 cm at least. A hard wood must be used. This wood must not rot, or be easily attacked by termites.

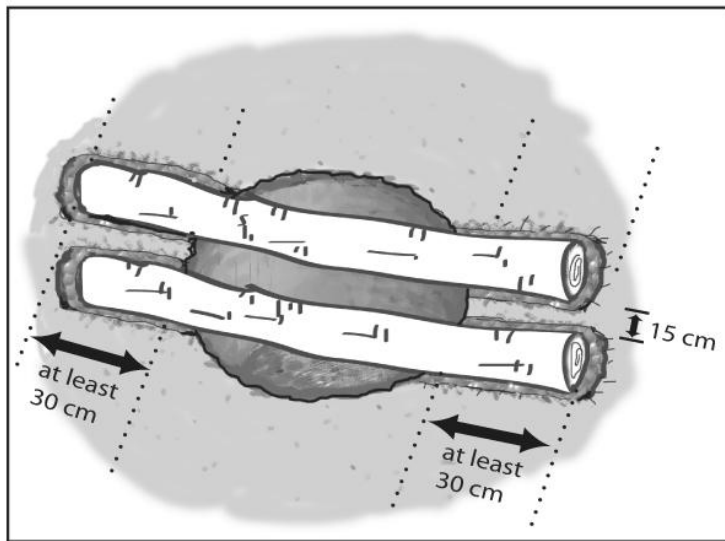

The wood can be protected against termites by painting it with used engine oil, a mixture made from the seeds of the Neem tree, or the use of any other adequate treatment

Strong pieces of wood are used to cover the pit, laying them on top of and across the two big logs. This wood must be of the same quality as the big logs.



To better support the second layer of wood, it can be fixed in place by four wooden pegs fixed in the ground. Any means of helping to better secure this second layer of wood and join it to the first layer should be carried out.

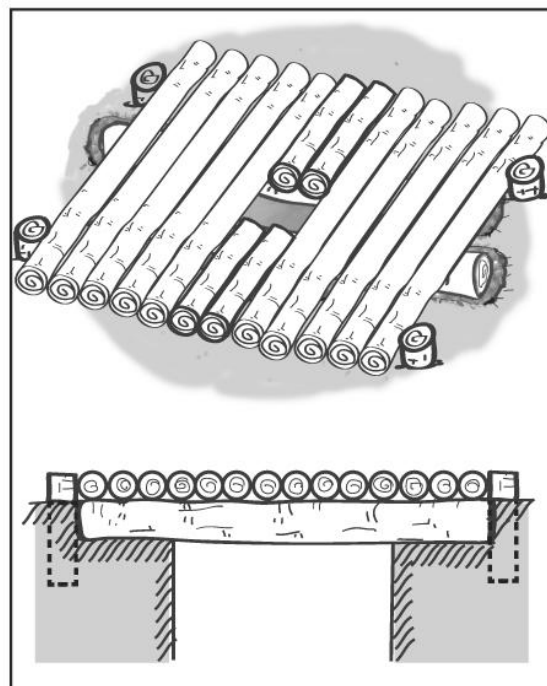

The squat hole must not be too large: 25 cm length and 15 cm width is adequate.

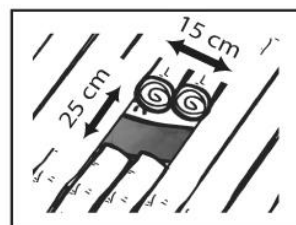

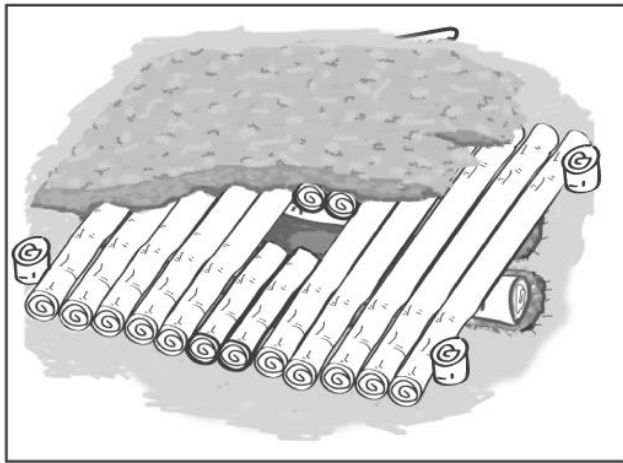

After this, you must compact a layer of soil on the wood. It is important to use a good soil for the compacting, a lateritic soil for example.

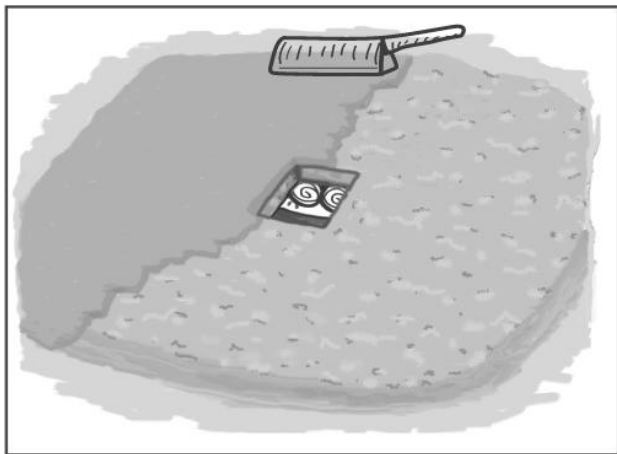

To complete this slab, an impermeable and smooth surface is added onto the top with lateritic soil mixed with animal dung (cow dung) or with a decoction of Nere tree seed pods. Some people use simple termite-hill soil.



A small quantity of cement can be used to smooth the upper part of the slab and make it impermeable.

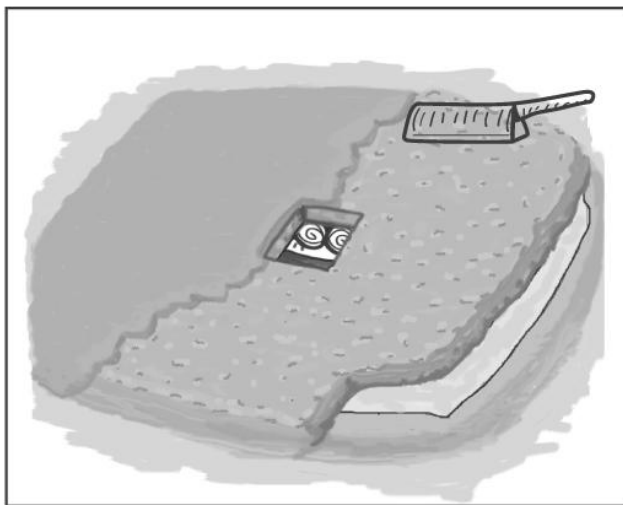

It is possible to place a plastic sheet between the two layers of compacted soil in order to avoid the slab being damaged by the infiltration of water.



You must earth up the soil around the slab to avoid the risk of stagnant or flood water entering the pit. A superstructure with a roof helps to protect the slab against damage from rains.

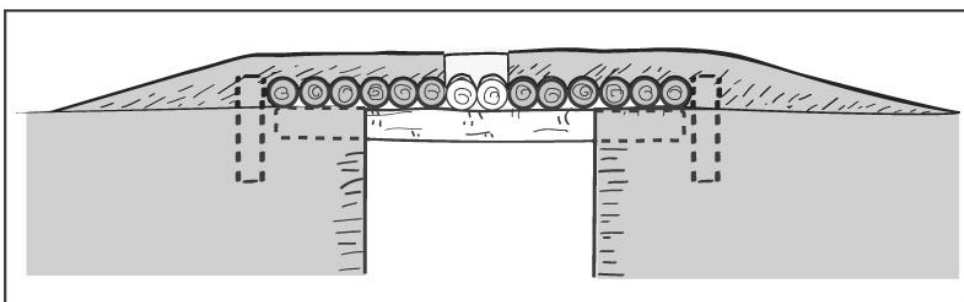



To avoid the pit collapsing, you must not construct the walls of the superstructure on the slab.

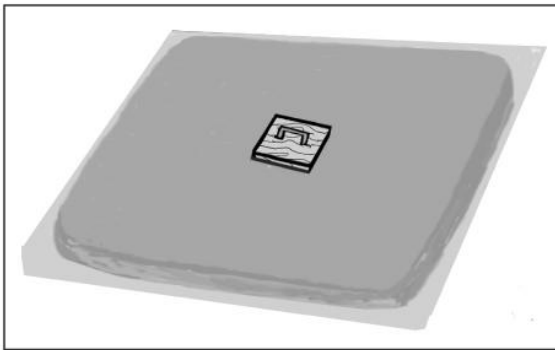
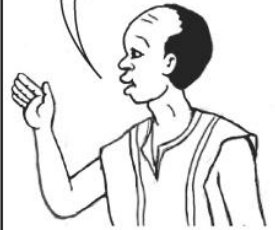
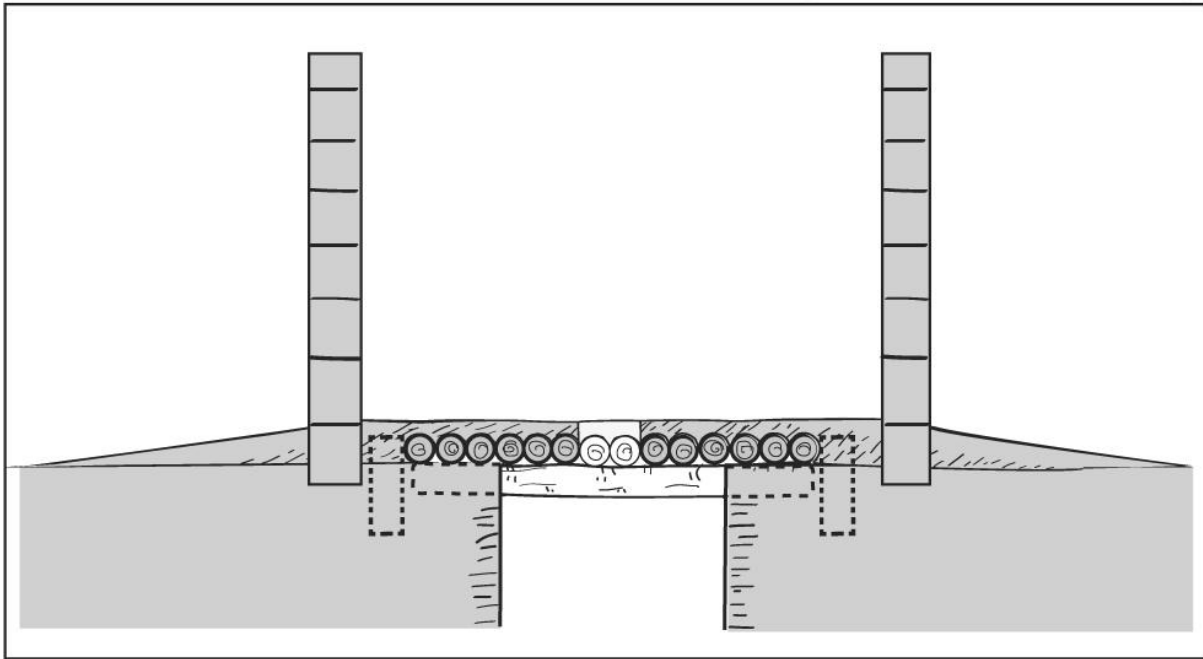

A lid is needed to cover the defecation hole after use.

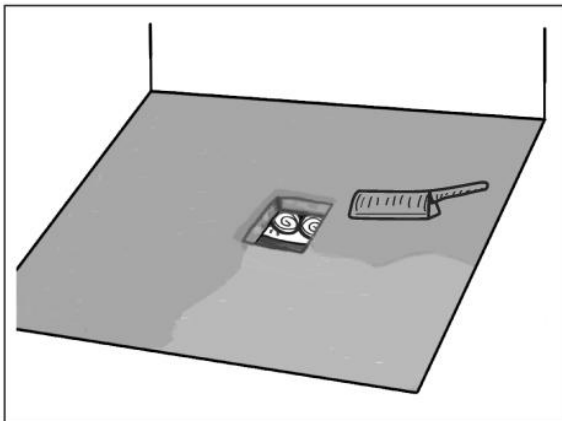

From time to time it will be necessary to renew the upper part of the slab in order to maintain a smooth and impermeable surface.

It is important always to keep the latrine clean and hygienic. It is therefore necessary to:

- Avoid getting faeces onto the slab or on the walls of the defecation hole;
- Regularly clean the inside of the latrine superstructure.



# Construction of the superstructure

Moussa, I don't know which superstructure to use. Yours, Arouna's, and Dieudonne's are all different. Which one would you recommend for me?

There is no 'best' superstructure. Each person makes his superstructure according to what he likes and can afford. The important thing is that the superstructure must give the latrine user privacy.

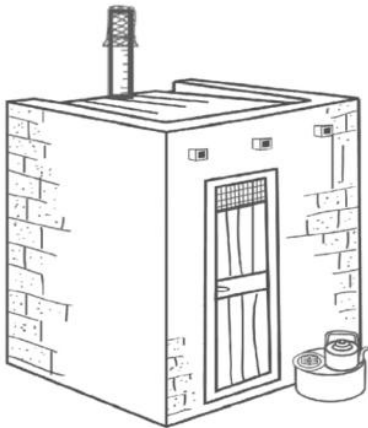
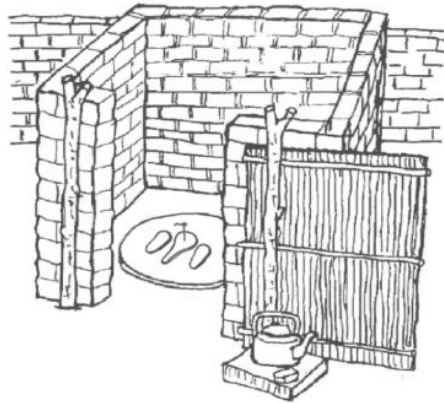
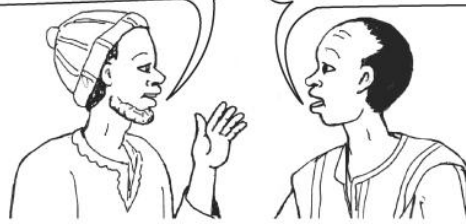

I am reassured. We will build the superstructure that is affordable for us.

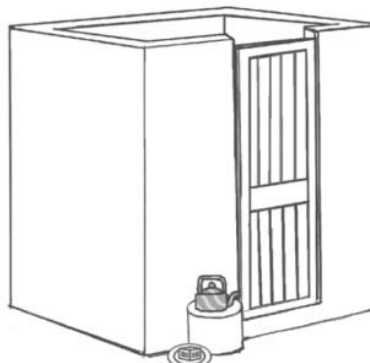
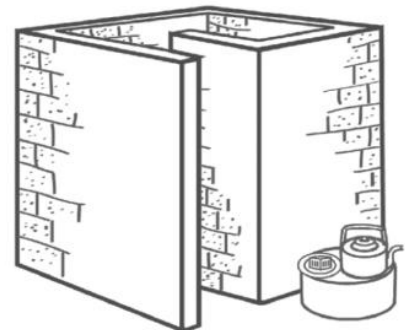
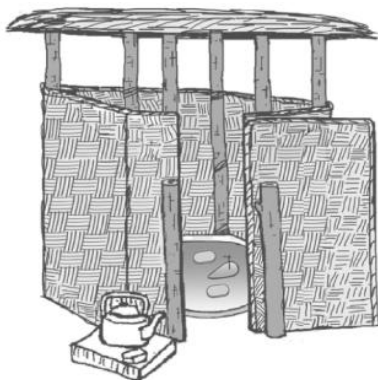
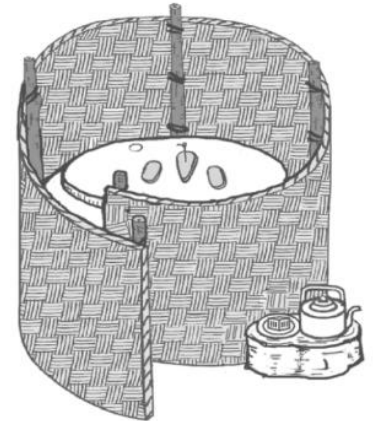

# What should I do when the latrine pit is full ?

What should I do when the latrine pit is full ?



You must dig a second pit.

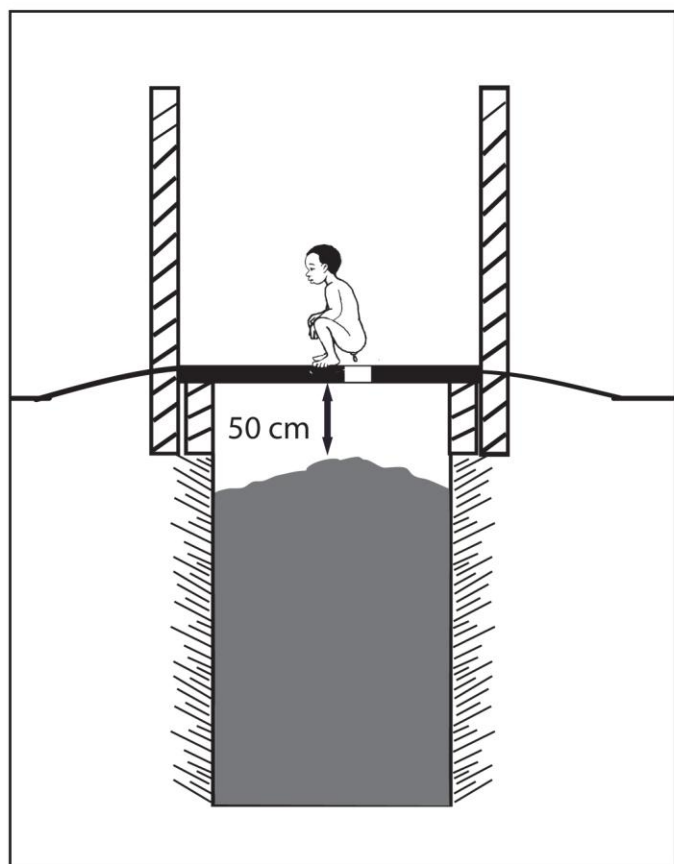

The second pit must be dug when the faeces in the first pit reaches to 50 cm below the ground level. The second pit must be located at least 3 m from the first one.



You must move the slab from the first pit to the second pit, and then fill in the first pit.

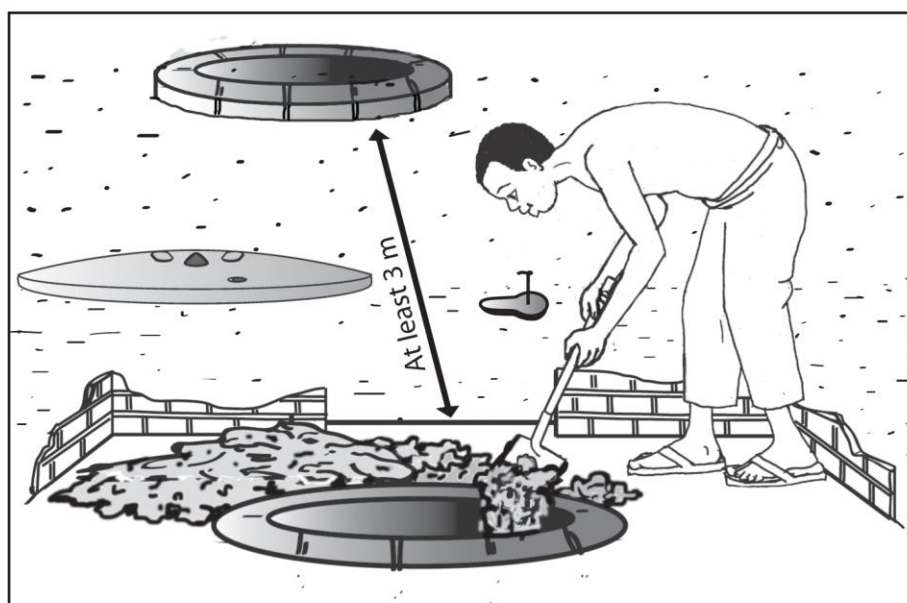

Before re-using the slab, you need to make sure that it has not been damaged. Also, make sure you wash your hands with soap or ash after handling the slab.

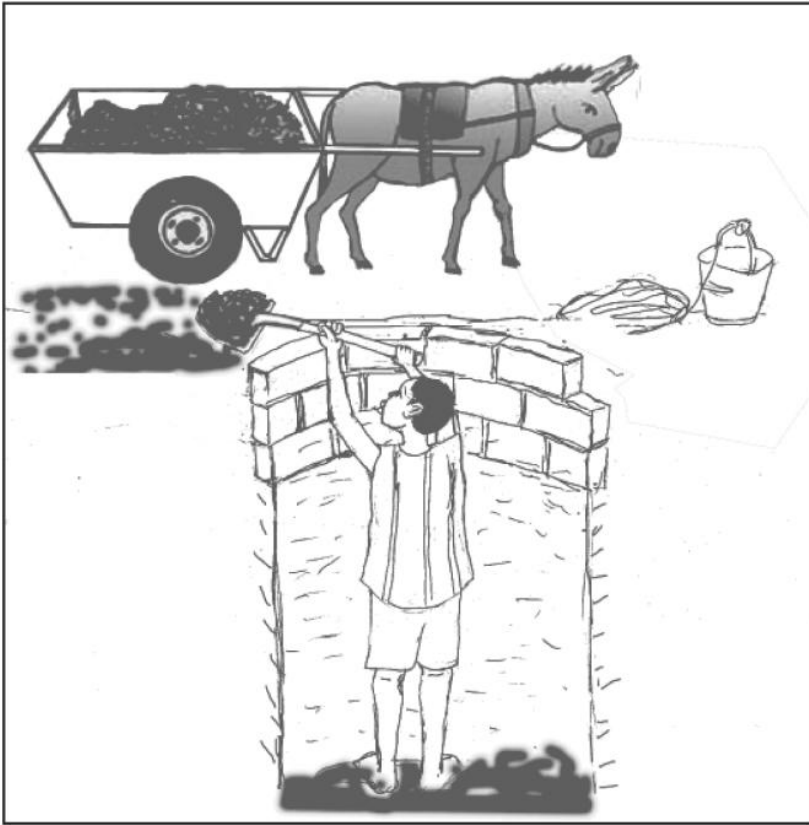

When the second pit is full, the faeces of the first pit will be well decomposed and safe and can be used as a natural fertilizer, and then after emptying it you can reuse the pit as a latrine again.

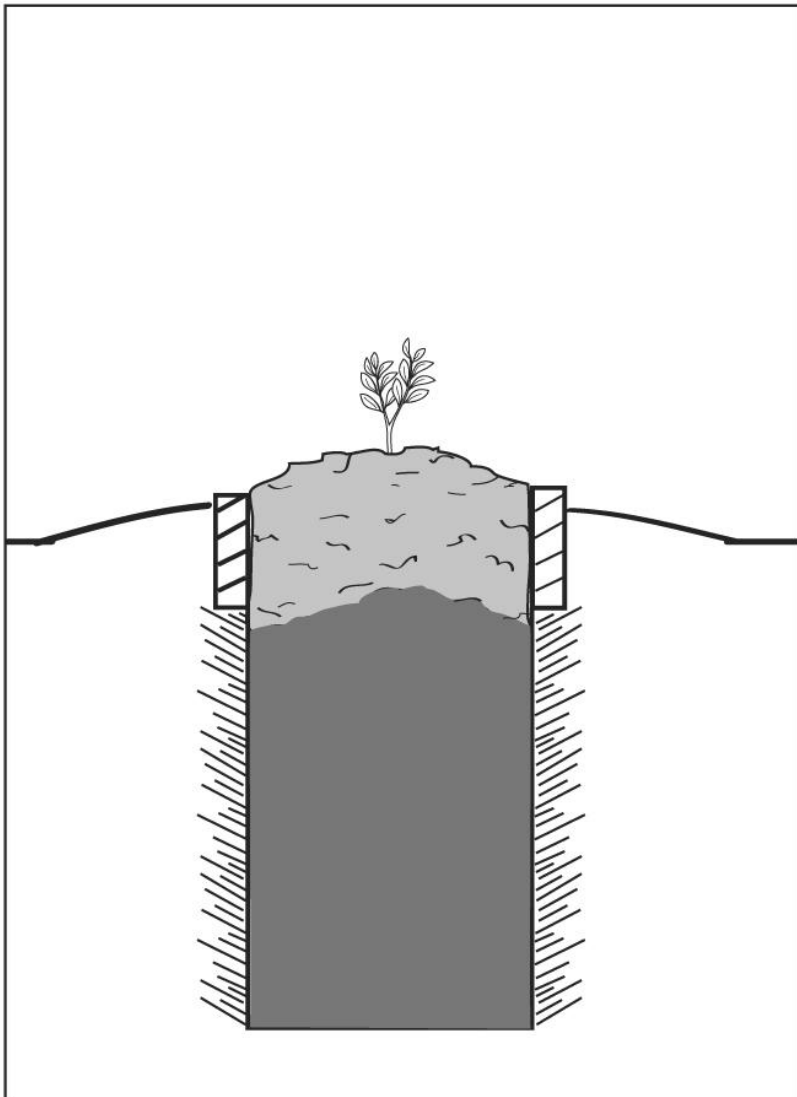

If you have enough space to dig a new pit once the previous pit is full, you can immediately plant a fruit tree that will produce beautiful fruit thanks to the compost in the pit.



# Using and maintaining the latrine

Finally, you have to make sure that the latrine will be used and maintained properly. Some things are very important.



You must be well positioned over the defecation hole to avoid getting faeces on to the slab.

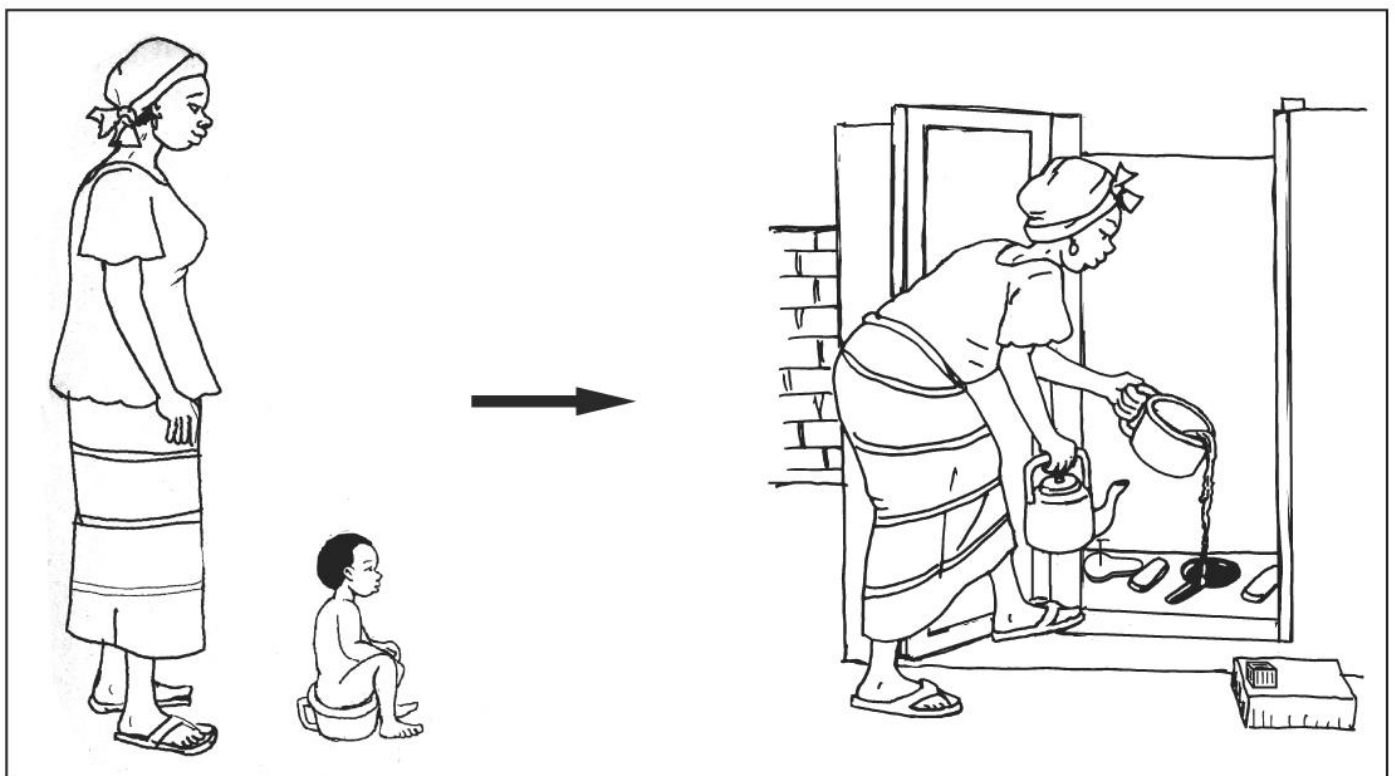

Very small children must defecate in pots and their faeces be emptied into the latrine.



After using the toilet, it is good to put ash on the faeces. This helps to reduce the smells, and kill the eggs of flies.

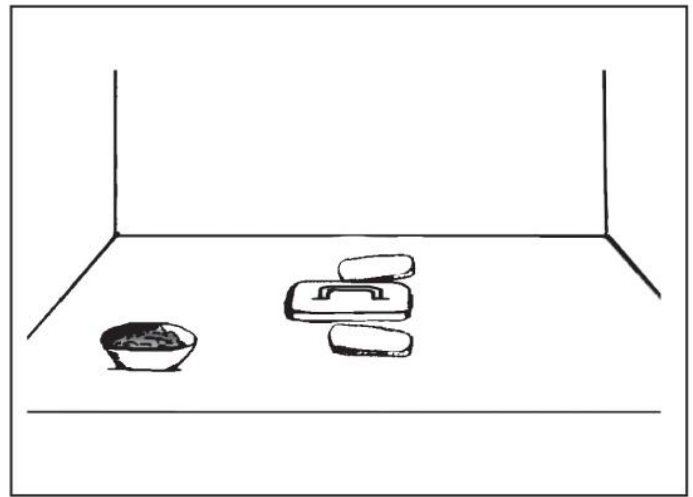

Except for the VIP latrine, the hole of the latrine slab must be covered after use.



The slab must be cleaned regularly.



You must wash your hands with soap or ash every time after you have been to the latrine.

It is important to have hand washing facilities (water, soap or ash) near the latrine at all times.

Arrange the area to avoid stagnant water.

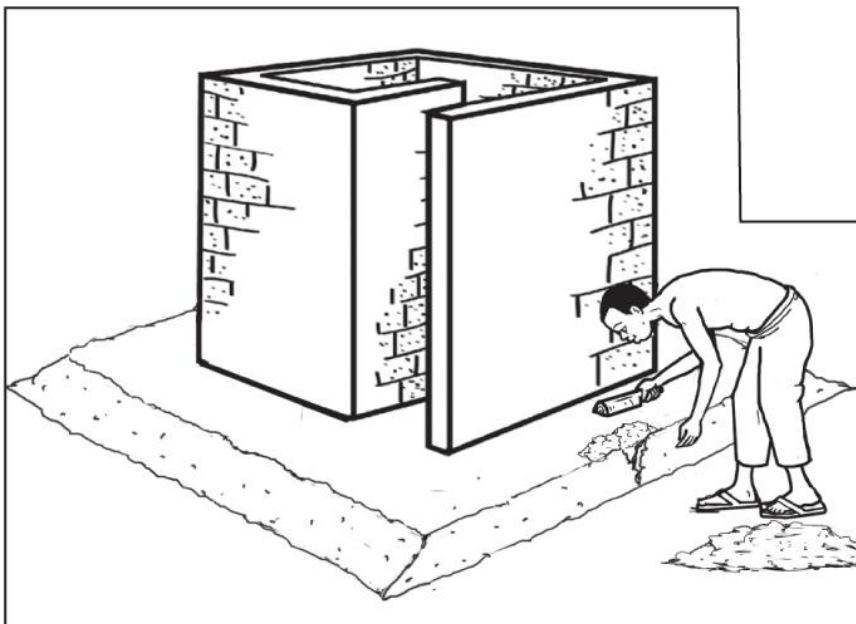

You have to maintain the latrine regularly: fill holes made by rodents, frequently patch the embankment around the latrine, maintain the superstructure, etc.

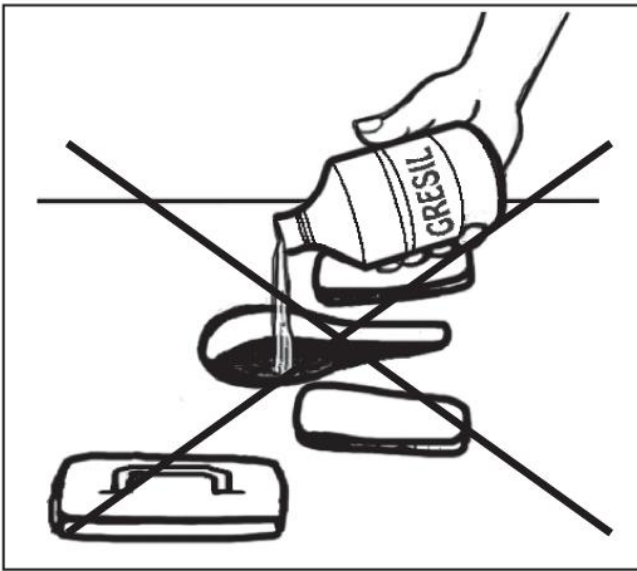

You must not pour chemicals ("Gresil", bleach, etc.) into the pit. If you do the faeces will not be transformed into manure.

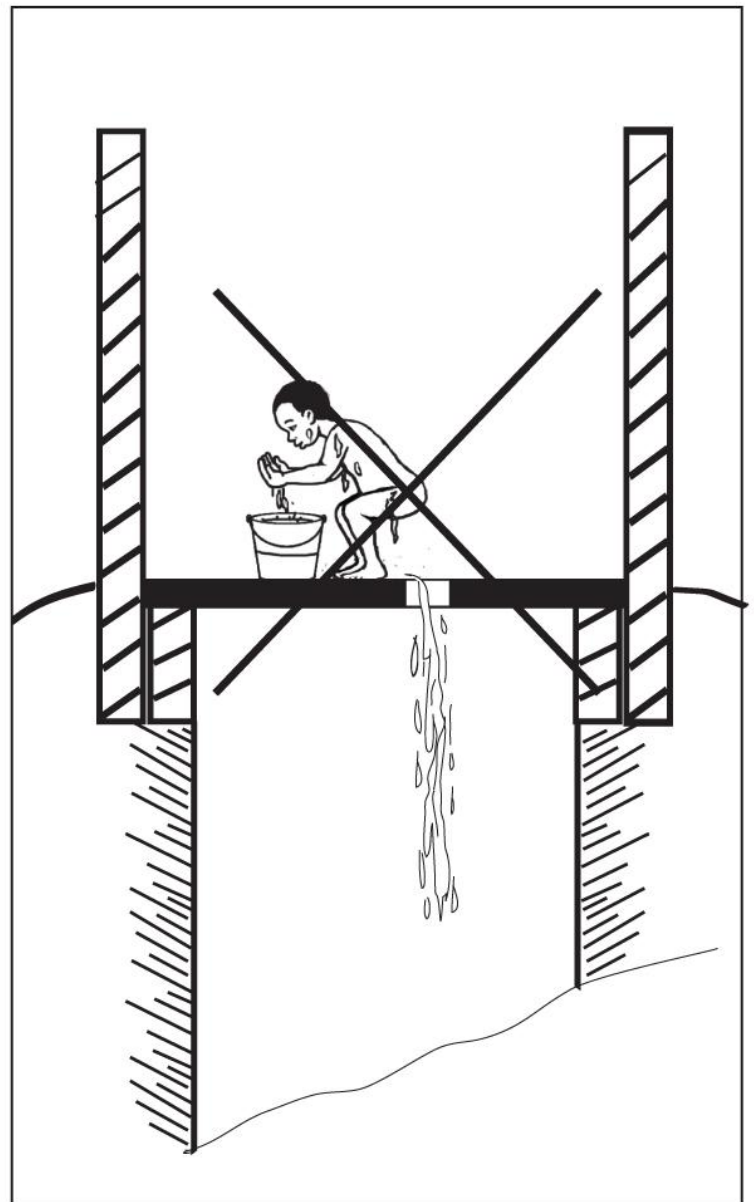

Do not use the latrine as a shower.



You must not put garbage in the latrine pit. The latrine will fill up very quickly and you will soon have to dig another one.

# What has Laurent done after getting this information?

Having followed the recommendations and advice of Moussa, Laurent built his latrine.

He and his family are using and maintaining it well.

Laurent doesn't forget to remind his children to wash their hands after using the toilet and gives them a good example himself.

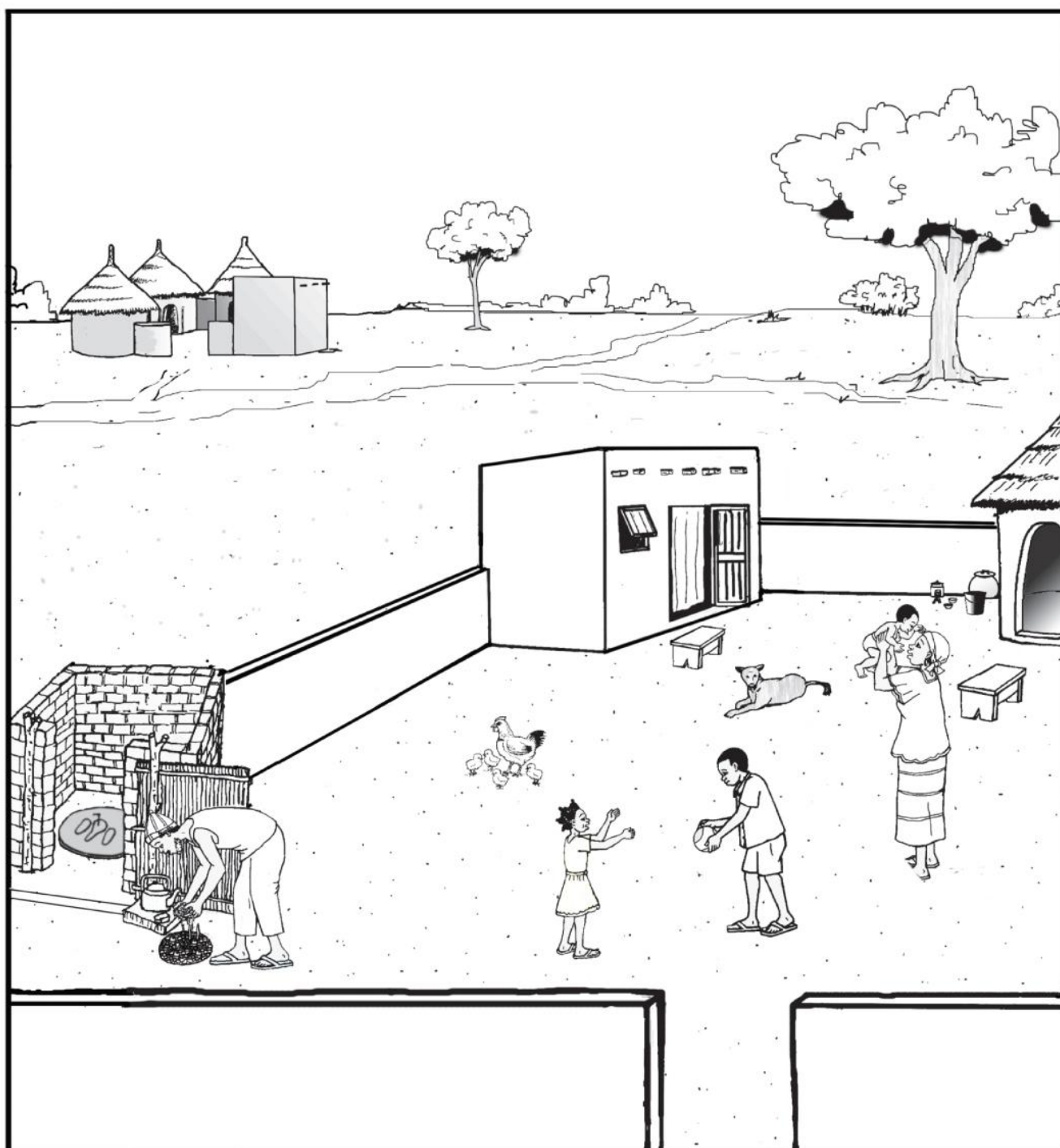





## **The Global Water Initiative**

A Partnership Funded by the Howard G. Buffett Foundation

This guide was developed by:

Sue CAVANNA, Jean-Philippe DEBUS, and Lambert Zounogo P. NIKIEMA,

with valuable contributions from:

Cyrille AMEGNRAN, Adamou BOUREIMA, Peter J. CHAMMIK, Sibiri Joseph CONGO, Philip K. DARKO, Ely DEMBELE, Isack DOLO, Morou HAMADOU, Marcelin ILBOUDO, Adama KONE, Kabirou MOUTARI, Matar NDAO, John NEDJOH, Ada OKO-WILLIAMS, Nouhoun SANOU, Lassana G. SINGARE, Jamie SKINNER, Dieudonné SOMBORO, Jules Auguste SOW, Sulemani R. SUFYAN, Ludovic TAPSAOBA, Mireille TIENDREBEOGO, Lassina TOGOLA, Sahada TRAORE, Peter WRIGHT.