

Oxfam Water Supply Scheme for Emergencies

This equipment is part of several packages devised by the Oxfam Public Health Engineering Team to help provide a reliable water supply for populations affected by conflict or natural disaster. The equipment is designed to be used with any or all of the following Oxfam water equipment: Water Pumping equipment, Water Coagulation and Disinfection equipment, Water Filtration equipment, Water Distribution equipment, Well Digging equipment, and Water Testing Kit. All are designed using available, easily transported equipment which is simple, rapidly assembled, and fully self-contained, to provide an adequate, safe water supply at moderate cost. The principles used in these packages may often be useful in long-term development projects.

The Oxfam equipment packages, which consist of “Oxfam” tanks (steel sheets, rubber liners), diesel water pumps, 3” PVC pipes etc, have been used successfully in the last two decades in often harsh environments, ranging from tropical to temperate climatic areas. Although this equipment is designed for emergencies, if installed and protected adequately it can give many years of useful service, though some up-grading works will be necessary to prolong its life. This equipment can be dismantled and re-used elsewhere.

However, these Oxfam equipment packages, while being simple to erect over a period of days, yet durable enough to last several years, do not lend themselves to very rapid deployment in a few hours. Increasingly, the nature of work which Oxfam has been called on to undertake has required equipment that can rapidly deployed then dismantled and moved to other locations. This has led to the development of the so called “rapid response kits” since the mid-1990s. This type of equipment is seen as a necessary complement to the original Oxfam equipment and is best used to provide a start up package in the absence of a detailed assessment and where affected populations are likely to be highly mobile. The relatively higher equipment costs and lack of suitability for anything other than short term water supply means that the deployment of the “rapid response kits” should be used only where appropriate.

Read this manual through before starting installation.

Contents

SECTION A - EQUIPMENT USE AND SYSTEM DESIGN	2
Storage tank erection and volume requirements	2
Storage tank siting	3
SECTION B - WATER STORAGE KITS AND ERECTION INSTRUCTIONS	4
Water storage kits	4
Erection instructions for rapid response PVC tanks	5
Erection instructions for rapid Oxfam tanks	6
SECTION C - OPERATIONAL INFORMATION	17
Rapid response PVC tanks	17
Oxfam tanks	17
SECTION D - DETAILS OF KITS AND SUPPLIERS	20
Full list of kit contents	20
List of suppliers	23
Final reminders, recommendations and acknowledgements	

SECTION A - EQUIPMENT USE AND SYSTEM DESIGN

The water storage equipment consists of kits for 45m³, 70m³, 95m³, and 11m³ capacity "Oxfam" tanks made with steel sheets and rubber liner, a range of lightweight rapid response PVC tanks, and a variety of complementary kits designed to assist in tank erection.

The 11m³ litre Oxfam Water Storage tank is suitable for use in situations where a group of 500-1,000 people are living in temporary accommodation such as hospitals or feeding centres, or where a larger number are coming each day, for example to collect rations. The kit is particularly designed for ease of transport, being of low weight and volume. It also can be used to house water treatment kits such as the upflow clarifier and roughing filter.

The larger 45, 70 and 95m³ Oxfam tanks are suitable for use for bulk water distribution to larger groups of people and some water treatment processes. Each of these tanks comes complete with corrugated steel sheets, a synthetic rubber liner and a PVC roof cover.

The lightweight rapid response water storage tanks comprise a 6m³ trucking bladder tank for use in water transport, a 10m³ bladder tank for static water storage and a 30m³ onion tank for water treatment and storage.

The rapid response tanks are very simple to install. A brief explanation appears at the beginning of Section B (Storage Kits and Erection Instructions). This manual also shows the recommended linked tank/pipe-work arrangements on which the Tank Fittings Kit (TF) is based, which allows three Oxfam tanks to be linked together.

The range of complementary kits (Tank Fittings Kit, Tool Kits, and Ladder/Scaffolding Kit) should be ordered as required. In addition, details of the kits required to undertake various water-treatment processes such as sedimentation, filtration, and disinfection are explained in the Water Coagulation and Disinfection manual and Water Filtration manuals.

Storage tank system selection and volume requirements

It is common practice to choose a combination of the water tanks to give sufficient storage volume of potable water for one day's water supply for the population to be served, based upon the SPHERE-recommended figure of 15 litres/person/day. This provides a back up where there may be unexpected breaks in water supply. This figure is based upon water requirements for drinking and food preparation, which require higher quality water, as well as water needed for clothes washing and bathing. Where nearby sources of water, such as streams and rivers are available and the safe use of these for washing clothes and bathing can be managed, it may be appropriate and necessary to initially size the storage volume on the water required for food preparation and drinking only, i.e. a minimum of 5 litres / person / day.

In designing a system, it is important to be aware of peaks in water demand. These nearly always occur in the hours around dawn (assume 50% of demand) and before dusk (assume the other 50%). Although it may not be possible to satisfy these peaks at the start of an emergency and water collection may have to occur over the entire day (12 hours or longer), water production/delivery and storage capacity should be expanded to meet this after a few weeks. Long queues for water occurring throughout the day are one of the clearest signs that the system as a whole is not able to deliver what people need.

Storage tanks are required for collection of water from springs or water produced from continuous flow water treatment systems, e.g. from upflow clarifiers or slow sand filters. There should be sufficient storage volume to store all water produced overnight, as this is unlikely to be collected by users during the night. Storage tanks also have secondary functions such as ensuring a constant water supply to treatment processes, providing a level of treatment by settlement of larger suspended solids and maintaining pressure in distribution systems.

The number and type of tanks required for a particular situation needs to take into account all of the above. In summary, ensure you have designed for:

- One days storage
- Peak demand
- Water treatment requirements (may require additional tanks)

In addition to these points take into account;

- Whether population is likely to be static or moving.
- The number of locations to be served.
- Requirements for special facilities such as clinics, schools, etc.
- Whether water trucking tanks are required.

Storage tank siting

Whenever possible, tanks used both for final storage and as part of a water treatment system should be sited on high ground, so that water can be distributed by gravity to the water collection points – often Oxfam tapstands. Where more than one tank is required, tanks can be built separately or grouped together, depending upon the size of population and the size of the area they occupy, the location of the water source(s) and operational considerations. Where the population is served by a piped

system from a distant source (1km or more) it is both economical and practical to site the storage tanks as close as is possible to the population. This is because the pipes serving the population (discharge pipes) need to be larger to cope with peak demand. The delivery pipes, by contrast, can often be smaller, needing only to provide a steady flow to the storage tanks.

Where water will need to be delivered by truck, ensure that the trucks can reach tanks or that a pump and sufficient pipe is available to empty the truck.

Finally, ensure that proposed tank locations are well drained and not likely to flood, taking care to identify where overflow water, waste water from treatment processes etc. can be disposed of.

A thorough survey of the site should be made before proceeding with any work, to ensure that all of these factors are taken into account. For very basic systems, such as bladder tanks, a simple look around will be sufficient, but for larger systems level surveys, population locations and site dimensions should be established on a plan. Operational, security and land ownership issues also need to be taken into account.

SECTION B - WATER STORAGE KITS AND ERECTION INSTRUCTIONS

Water storage kits

This manual explains how to use/erect the following tanks (detailed kit lists are provided in section D):

Oxfam Code	Description
TRT6	6m ³ Trucking bladder PVC tank
TBT10	10m ³ Ground bladder PVC tank
TRR30	30m ³ Onion PVC tank
T11	11m ³ Tank sheets, liner and roof
T45L T45R T45S	<i>*45,000 – litre Storage Tank Kit, comprising:</i> Tank liner and accessories Tank roof and accessories Tank sheets
T70L T70R T70S	<i>*70,000 – litre Storage Tank Kit (Contents similar to the 45,000-litre tank)</i> Tank liner and accessories Tank roof and accessories Tank sheets
T95L T95R T95S	<i>*95,000 – litre Storage Tank Kit (Contents similar to the 45,000-litre tank)</i> Tank liner and accessories Tank roof and accessories Tank sheets
TF	Tank Fitting kit
OS	Site tool kit
OT	Scaffolding tower
OL	Ladder for tank erection

* Note that a complete 45m³, 70m³ and 95m³ Oxfam tank is made up of three boxes/pallets, consisting of sheets (S), liner (L), and roof (R). The sheets, liner and roof of the 11m³ Oxfam tank are packed in one box.

The following table shows the sizes of the Oxfam tanks and the number of galvanised steel rings used in each.

Nominal Storage Capacity (litres)	Oxfam code	Height (m)	No. of rings high	No. of sheets per ring	Diameter (m)
11,000	T11	2.3	3	6	2.6
45,000	T45S/L/R	1.5	2	7	6.4
70,000	T70S/L/R	2.3	3	7	6.4
95,000	T95S/L/R	3.0	4	7	6.4

Erection instructions for “rapid response” PVC tanks

The instructions below refer to the three types of rapid response tanks, which are very quick and simple to install. The diagrams serve to show what the tanks look like when set up. These tanks typically take half an hour to set up.

10m³ bladder tank

1. Select a site that is fairly level and firm, ensuring that the tank will be at least 1m higher than the tapstand. Mark out an area 4.5m x 3m, with the shorter side facing the direction in which tapstand will be positioned, and within this clear away all vegetation, roots, boulders and stones. If required make site level and smooth by using a layer of sand or soil. Lay out the groundsheet on the prepared area and roll out the bladder tank, ensuring outlet stubs are positioned towards the tapstands. Connect pipework as required, using the 3" M x 1" F reducer if connecting a tapstand directly to the tank.

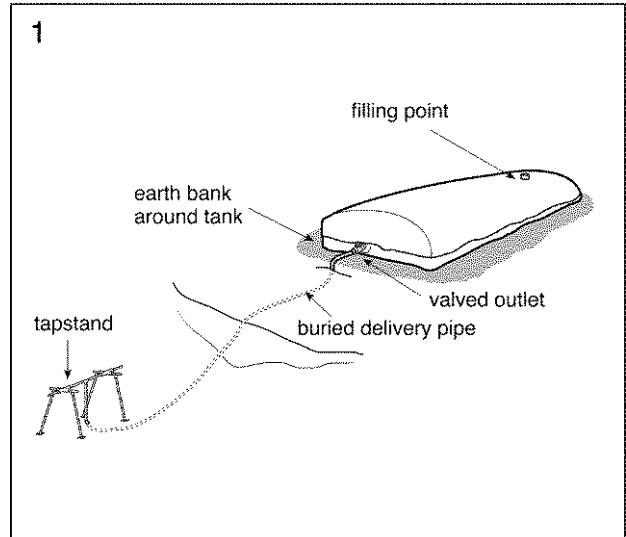

30m³ onion tank

2. Site selection, ground preparation and installation for this tank is similar to the bladder tank, except a 6.5m diameter circle should be marked out and particular care should be taken to ensure site is level, otherwise the tank will slump badly after filling. Connect pipework as required, using the 3" M x 1" F reducer if connecting a tapstand directly to the tank (sometimes the reducer on this tank is screwed into the inside where the valve exits). Add roof and tie down. Webbing loops can be used to peg down the tank if required (pegs/rope not supplied).

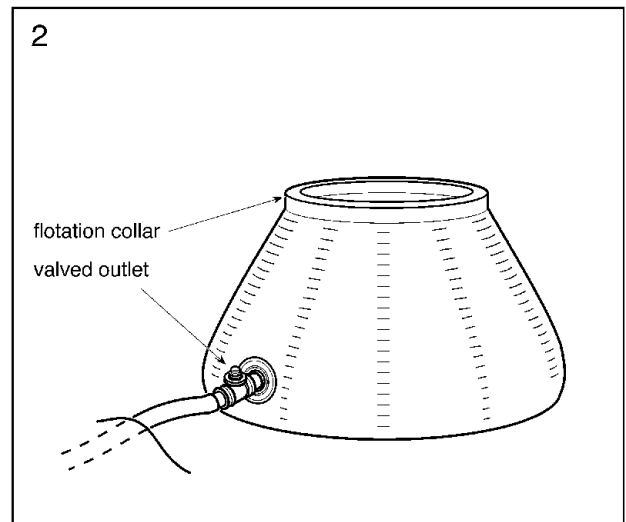

6m³ trucking bladder

3. This bladder tank is designed for water trucking only and is not really suitable for static water storage. Find a suitable flatbed truck, with truck bed at least 4m x 2.2m, with a minimum carrying capacity of 6 tonnes and with side hooks for tying the webbing straps. Ensure the truck bed is swept clean and is free from sharp edges that may damage the bladder. Lay out the groundsheet where the bladder is to be positioned. Roll out the bladder tank, ensuring that tank outlets are positioned at the end of the truck and are accessible for opening and closing. Lay out the heavy-duty webbing straps and hook to truck base. Once the bladder is full the straps should be tightened down securely. The truck is now ready to be driven and water can be transported safely.

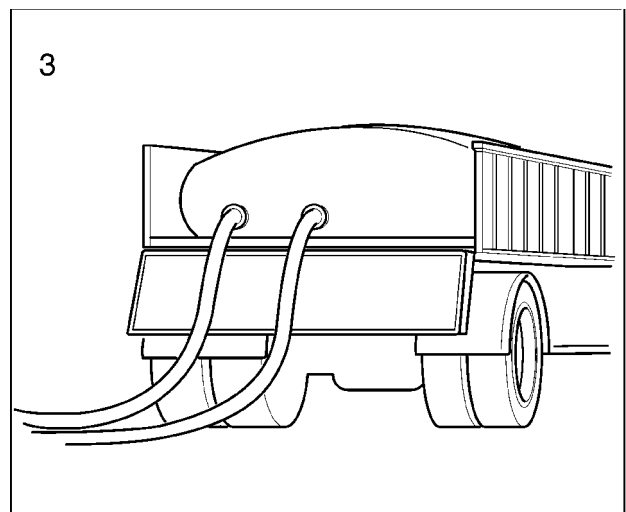

Erection instructions for Oxfam tanks

The instructions below relate to all Oxfam tanks, but the diagrams show the erection of a 45m³ tank; refer to the end of this section for special additional instructions on 70m³, 95m³ and 11m³ tanks. These tanks typically take 2 – 4 hours to erect. Do not attempt to erect these tanks in windy conditions. Even in calm conditions, **no tank should be left empty without guy ropes to stabilise it**. During construction, temporary guys can be run from the top of the tank to the ground.

4. Select a site that is fairly level, and firm enough to support a full tank, so that interconnected tanks can utilise their maximum storage capacity. Look for a site that is well clear of trees, to avoid problems of roots, falling branches, leaves, and canopy drip (which often brings with it living organisms). Where possible, site tanks on high ground or on a small well-constructed earth platform, to allow distribution by gravity. If several tanks are to be grouped together, before starting any work you should carefully consider the layout, to ensure that spacing and relative heights will achieve what you want the tanks to do.

5. Where an earth platform is required, it can be constructed using hessian/plastic grain sacks covered with plastic sheeting to stabilise the sides, though permanent installations should use concrete or masonry walls to stabilise a well-compacted soil core. Ideally the sides of the mound should be inclined at no more than 45°, and there should be a space of at least 1 metre from the edge of the sacks to the tank sheets, to allow for working room as well as platform stability.

6. When positioning tanks directly on the ground, use a stick and string to mark out circles of 4.2m radius, and within this circle clear away all vegetation, roots, boulders, and stones. It may prove necessary to cut or fill to produce a horizontal surface, but, if so, ensure that areas of fill are well compacted and protected from erosion. Using the same centres, mark out circles of 3.2m radius and on this line dig out a narrow trench about 50mm deep, into which the bottom ring can be set. (This prevents the liner from being forced under the rings).

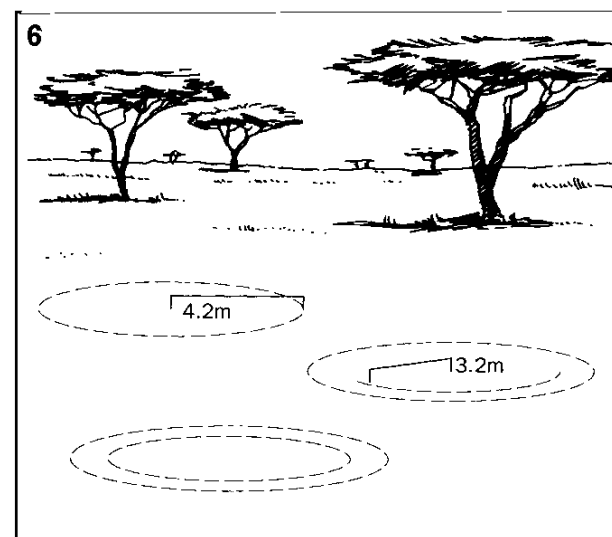
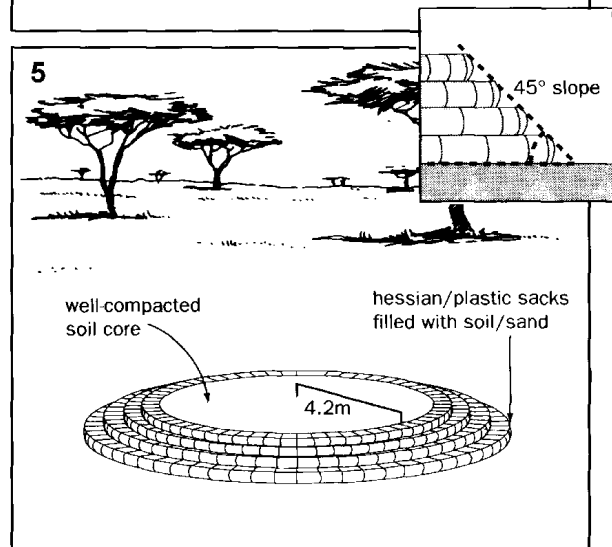
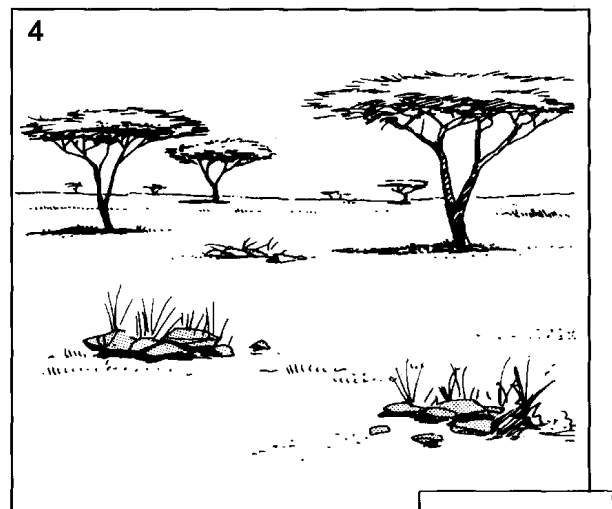

7. If sand is available, spread a layer up to 50mm deep to cushion the liner and prevent damage. Otherwise, ensure that the ground is smooth and free from all sharp projections.

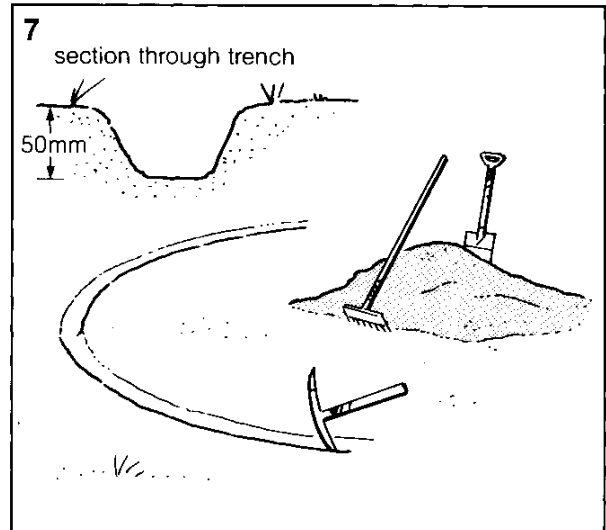

8. Place liner on the ground in centre of circle. Ensure that no oil or petroleum is in contact with liner (which causes damage as well as contamination). Choose direction of inlet/outlet and lay first ring sheets around circumference, with pipe holes in chosen locations. These tanks are provided with three sheets with one outlet/inlet hole in each of them. Typically one hole would be used for an outlet (at the bottom of the tank) and one hole for an overflow (at the top of the tank). The other hole could be used for an inlet (at top of the tank) or washout (at the bottom of the tank). An overflow pipe can be combined with the washout if required (see diagram 33).

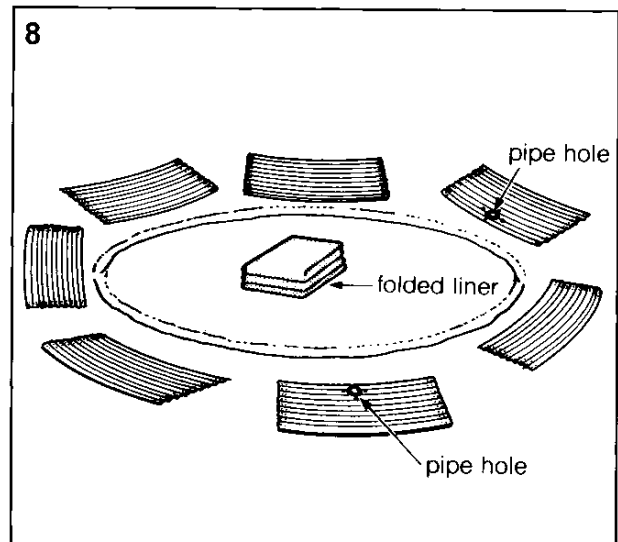

9. Working in pairs, one person inside and one outside the ring, stand the first sheet in shallow trench and bolt the next on to it, keeping all bolt heads on the inside. Overlap with one end inside, the other end outside. To align the sheets, first use the podger (spike) and insert bolts at top and bottom of sheets. Then insert remaining bolts. Do not fully tighten any bolts at this stage. Once the first ring of sheets is assembled, use a spirit level on each joint to get it vertical, and then the rest of the tank can be built up correctly from this.

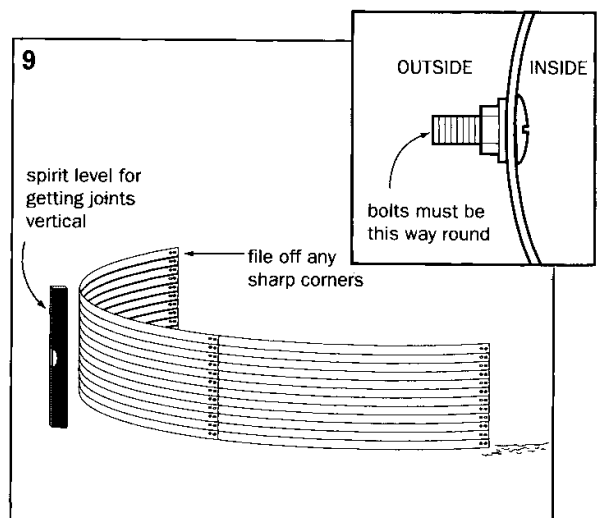

10. Complete first ring of sheets and then erect second ring. Stagger laps placing upper sheet between lower sheets. Choose position of blanked-off hole to be suitable for tank inlet or overflow outlet, if used. Tighten all bolts only when both rings are completed. When tightening, check that sheets fit snugly and that any dents or sharp edges on the inside of the tank that could damage liner are flattened or filed smooth. Finally, on inside of tank, cover joints between sheets with strip of self-adhesive tape (to protect liner).

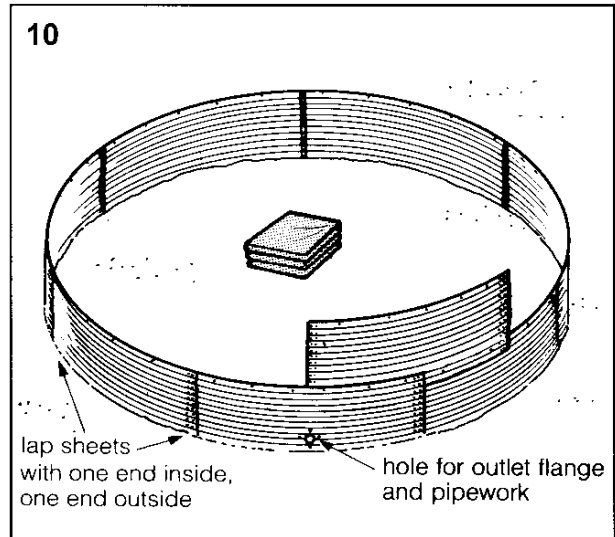

11. Fit smaller size of split PVC capping round top of sheets. (Bend capping back to open up split, then roll on and press down evenly round rim). Trim off any excess at the join. Tape capping to tank at 500mm centres.

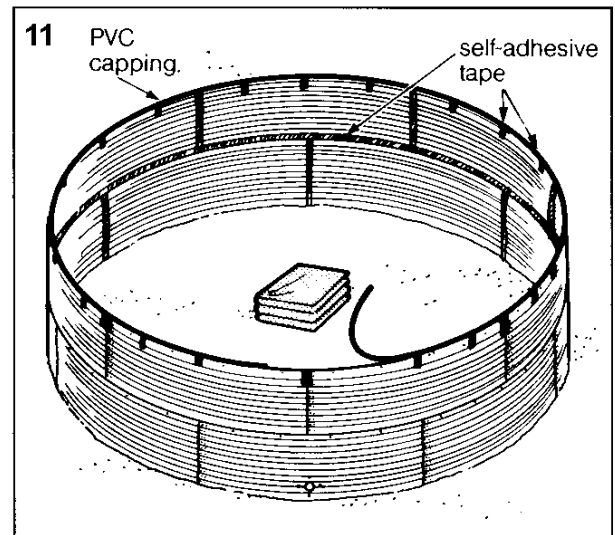

12. Installation of flange assembly is done in two stages, Stage 1 as follows (See step 16 for Stage 2).

Take the flange with the threaded 3" diameter pipe welded to it and, having cleaned their threads, screw four studs into the threaded holes so that they project 50mm on the same side as the pipe. Use two nuts locked against each other and a spanner if necessary. From inside the tank, pass the assembly through the holes in the tank wall. Screw on the gate valve and fully tighten. This may leave the gate valve handle in a non-vertical position, in which case the flange/gate valve assembly can be removed from the tank sheet, rotated until a vertical position is achieved and then put back through the holes in the tank sheet. Then tighten nuts and washers on the outside, flattening the corrugations slightly. Pass the first rubber gasket over the studs projecting inside the tank.

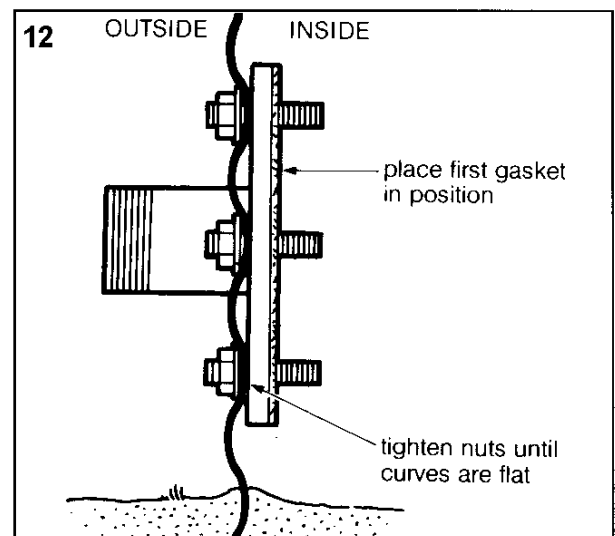

13. Backfill the shallow trench in which steel rings are sitting, adding soil or sand to make a fillet on the inside to support liner. Use two workers with bare feet (sandals are provided in the tool kit for hot weather) or rubber-soles shoes, free of any oily contamination, to unfold the liner inside the tank. Hands must also be clean. Carefully pull and smooth out the base area to fit as accurately as possible. The workers inside can, by leaning on the rim of the tank, kick the liner gently into the base of the wall. The seam in the liner between the circular base and the vertical walls should lie against the fillet of soil.

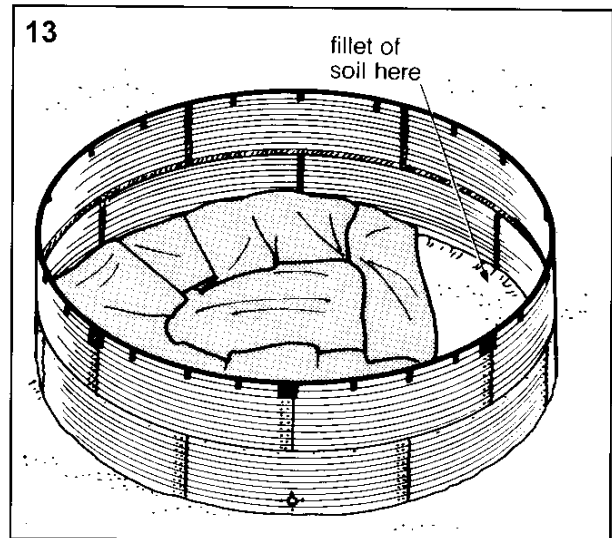

14. At this stage ensure that the vertical seams in the liner do not coincide with any of the holes in the tank sheets. If they do, rotate the liner base slightly. Lift the liner over the rim without disturbing the protective PVC capping. You now need many helpers on the outside, to hold the liner and prevent it slipping back inside, while adjustments are made to minimise wrinkles and to end up with an equal margin hanging down all around outside.

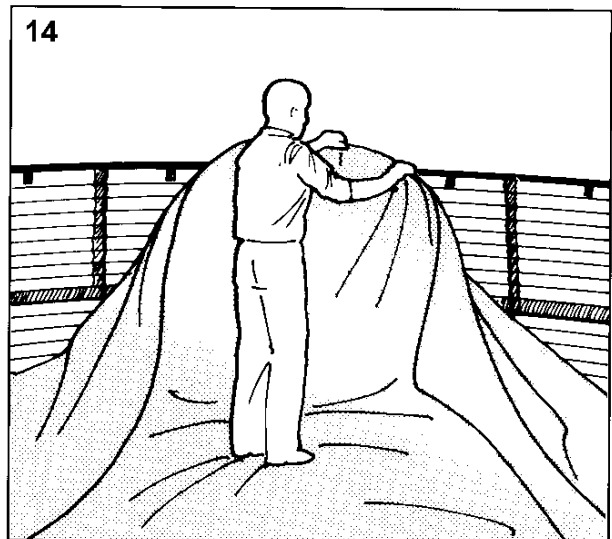

15. Secure liner with the larger size of split PVC capping and then snap on the spring clips over the capping at regular intervals of about 0.5m. If the length of capping has to be trimmed, peel back enough to enable the cutting to be done well away from the liner. Position a clip close to each side of joint.

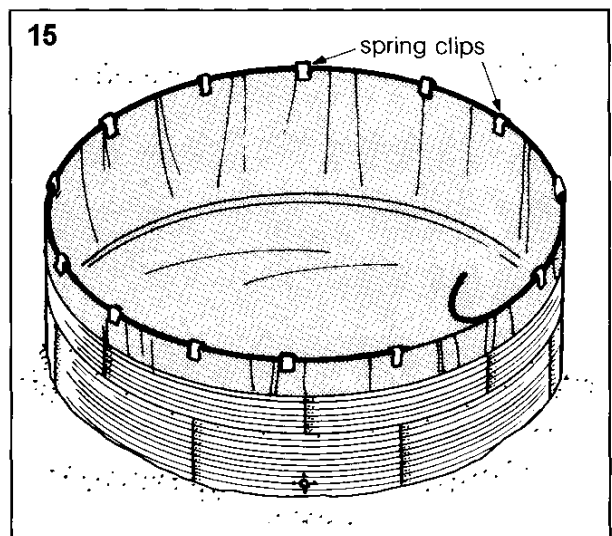

16. With the liner correctly positioned and not under any tension, cut four small circular holes in the liner by pressing it against the end of the studs and cutting around them carefully with a sharp knife or scissors. Slide the liner over the studs and against the first gasket. Now pass the second gasket and plain flange over the studs and wind PTFE tape on to the studs (to prevent leakage), before tightening on the inside nuts. Finally, cut the liner round the inside of the plain flange, leaving a 3"-diameter outlet hole. Fit overflow pipe-work at this stage, if using it (See step 21).

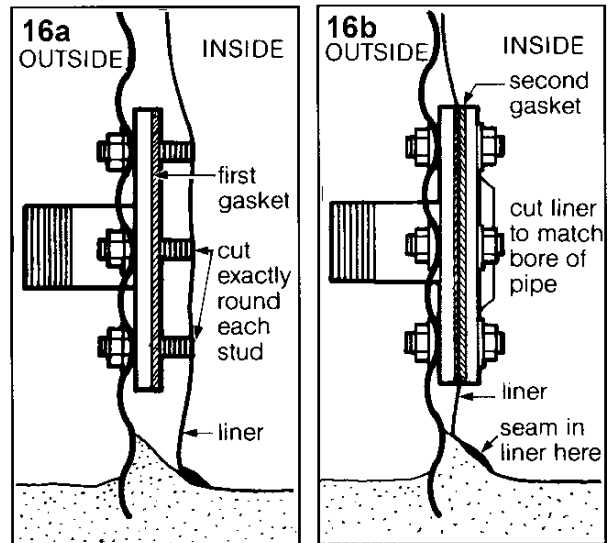

Roof Erection

17. a) Screw the eye nut on to the end of bolts joining upper and lower rings of tank sheets. Space equally round tank, four to each sheet.

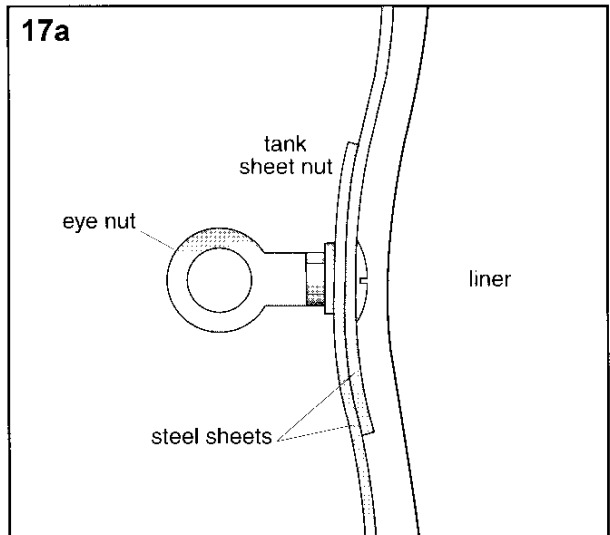

b) Assemble the support column from 2 pipe sections, connector, and two flanged ends, and stand column in centre of tank. **Do not** cut the pole length, as the roof pitch is designed to shed rainwater effectively (to prevent tank wall damage), which will not occur if the roof is less steep.

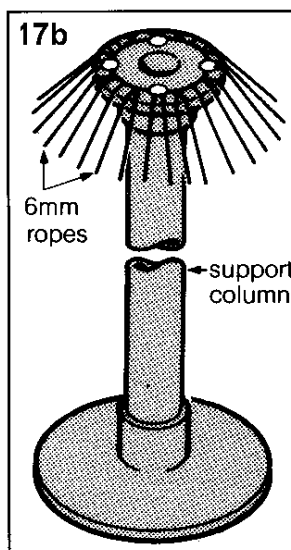

c) Pass ropes through the eye nuts, tension gently and tie off. Tension equally to provide support for PVC cover. Do not over tension, otherwise the tank sheets may bend.

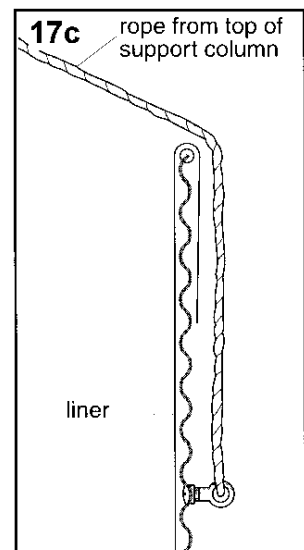

18. Lift circular PVC cover over central column and support ropes. Tension cover over tank wall and secure to eye nuts with 6mm rope passed through eyelets. Whilst this 40m coil of rope can be tied continuously through the PVC roof cover eyelets and eye nuts, it is better to cut the rope into 28 lengths, to make each tie off independent.

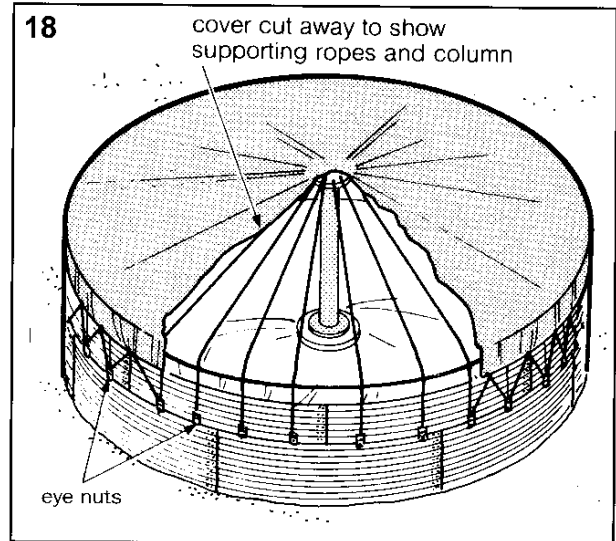

19. When the tank is in use, an inspection flap which is provided in the PVC roof near the tank edge and can be used for dosing chemicals, insertion of delivery pipe or inspection of the tank. Finally, either tie ten guy ropes to eye bolts spaces around tank and peg down, or bank earth against outside of tank to 1/3 of tank height.

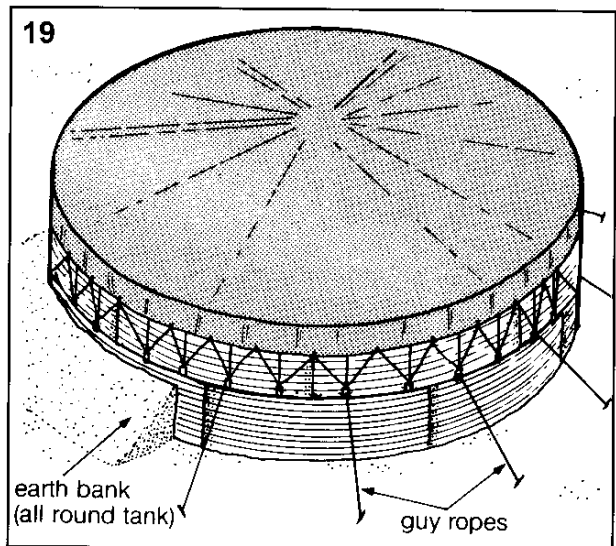

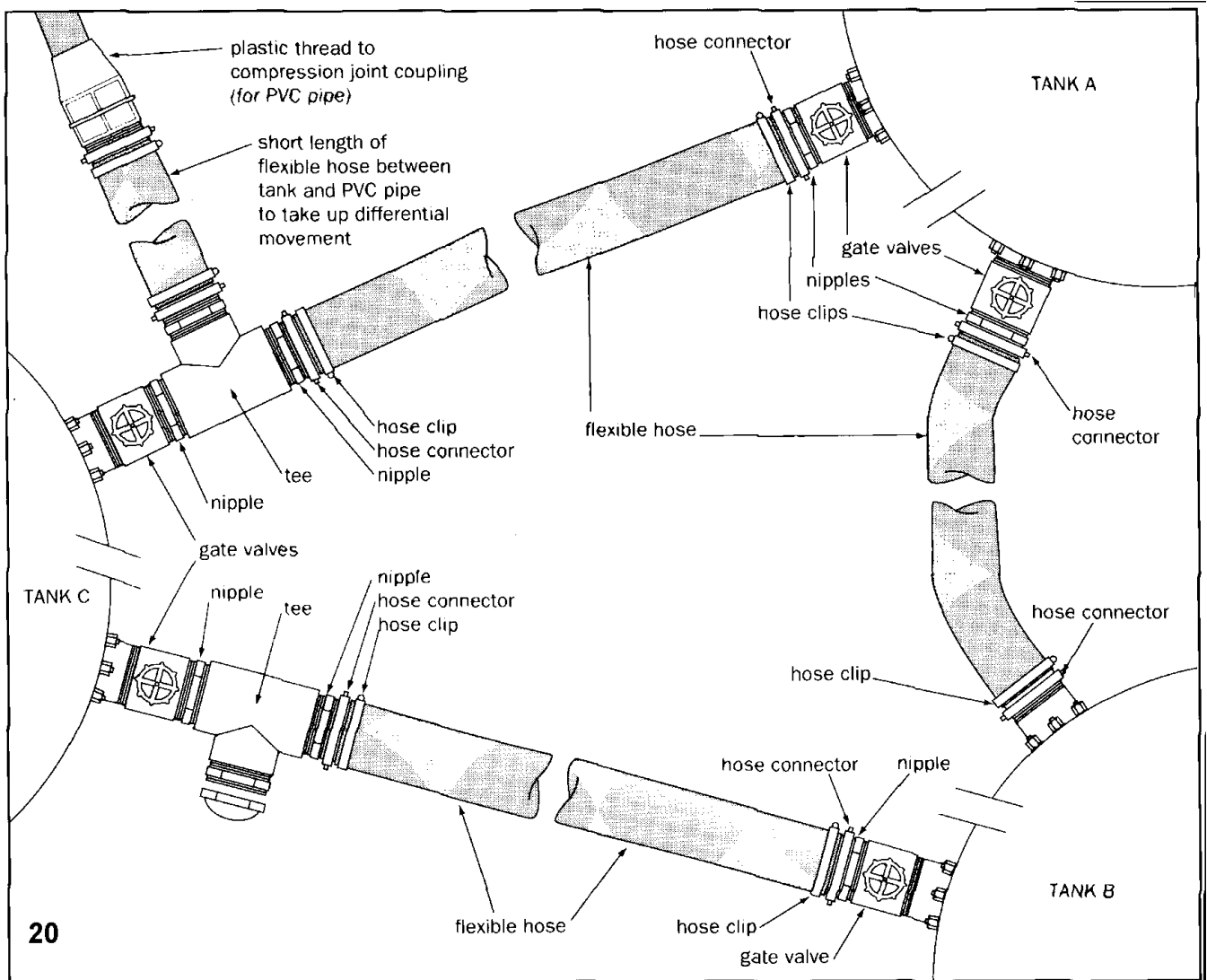

Link pipework connections

20. Where three tanks are linked together in a group, the connections layout shown should be adopted. The fittings in the tank fittings kit (Oxfam code TF) are based upon the layout shown. If, however, one tank is used on its own, the following points still apply for making the connections.

Screwed connections: clean dirty threads; file or trim where damaged. Wind on PTFE tape in a clockwise direction and ensure firm but not over-tight joint. Use 36" stillson.

Hose connectors: use pipe lubrication and push well into hose; fit clip towards end of hose and tighten bolt very firmly. Use gasket when screwing female connectors on to 3" threaded male fittings. The male hose connectors are a very tight fit in the hose and it may be helpful to warm the end of the hose in a flame to assist in getting these on.

Cutting flexible hose: best done with saw, as squarely as possible.

Valves: will require a hole to be excavated in the ground to allow them to be screwed on to tank flange. (If valve not previously fitted see 12.) Backfill hole soundly to support liner. Support hose locally to tanks or valves, to reduce strain on connector joint.

Overflow/inlet pipe-work

21. The following fittings are included in the tank fittings kits to provide one overflow arrangement per three tanks:

- 1 no. 3" BSP hex. nipple
- 1 no. 3" BSP female threaded elbow
- short length of 3" PVC pipe threaded at one end

Remove the blanking plate fitted to the chosen overflow outlet. Fix the flanges as described in steps 12 and 16. On the inside of the tank, screw in the nipple, elbow, and pipe as shown. Mark pipe 100mm down from level of rim of tank, unscrew, saw off, and replace. Use PTFE tape on all final screw joints, to avoid leaks. Finally connect 2m to 3m of hose to outlet flange, to discharge overflows safely away from base of tank. However if required the overflow could be combined with the washout (see 33).

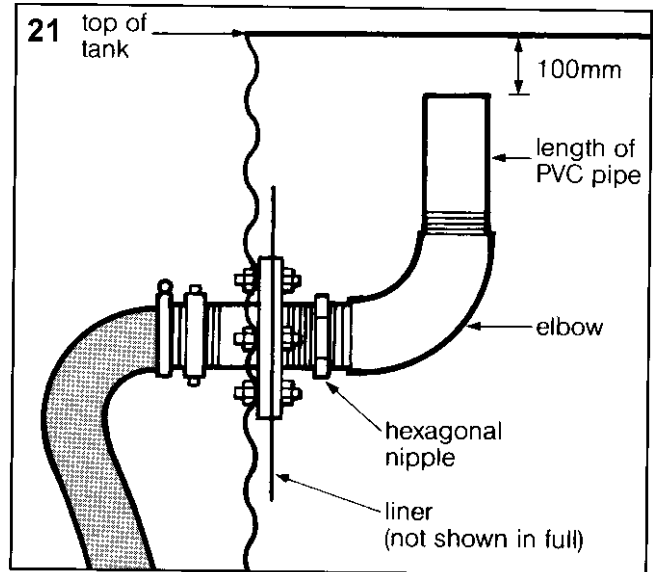

22. The inlet to the tank can be made by hanging a length of green flexible hose, or 2 elbows coupled to the hose, over the edge of the tank. However, if this is not supported with a frame, over the course of time it will bend the tank sheets slightly at the top, which should be avoided.

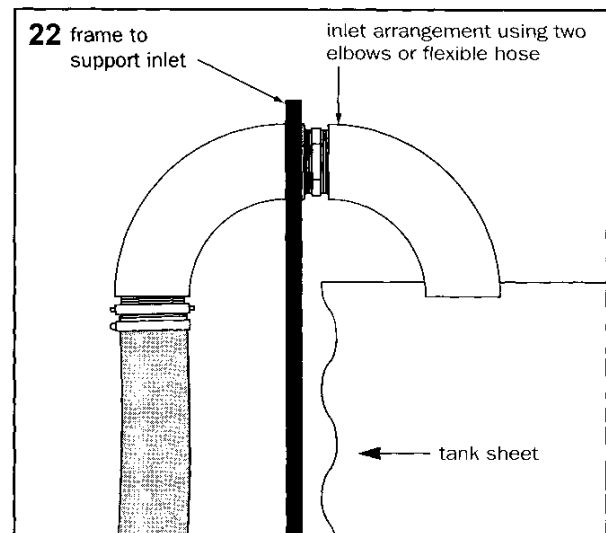

23. Alternatively, where overflow and washout are combined, an inlet arrangement with a flange and perhaps also a float valve could be used. Provision for the flange has been made in the tank liner kits, but not for the reducer and float valve, and extra fittings would need to be ordered as required.

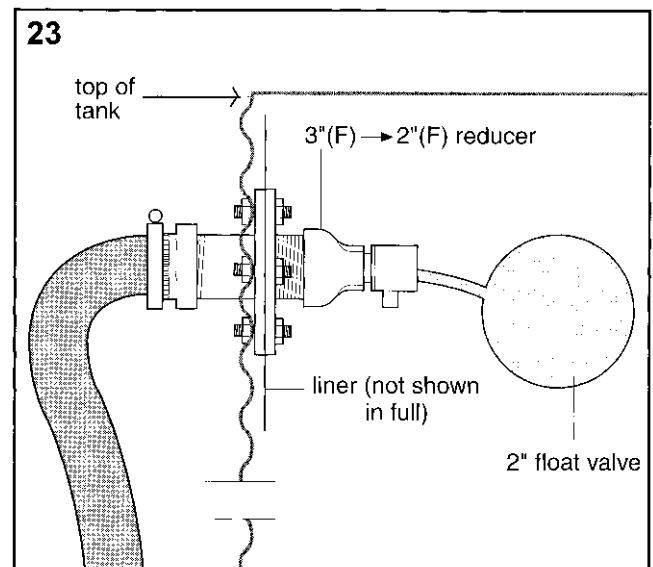

Additional erection instructions for 70m³ and 95m³ tanks

Erection of both these tanks requires either a step ladder or a simple scaffold platform, which have to be ordered when required. A platform of about half the final height of that tank is best, but empty fuel drums can form a convenient platform.

In black cotton soils, or other locations where ground conditions can be soft, it is inadvisable to erect tanks taller than 2.3m, unless stringent precautions are taken to prevent subsidence caused by erosion of foundations and wind pressure. This might require a gravel and/or concrete foundation ring and the use of extra guy ropes, or substantial earth banking round the tank. When erecting these tanks, tighten bolts in the bottom ring after two rings are completed; tighten bolts in the second ring after three rings are completed.

24. Upper rings can continue to be bolted outside lower rings or, if preferred, adjacent sheets can be woven in and out of lower ring (see illustration). This enables the upper sheet to be supported at its midpoint while its own bolts are inserted.

25. Attach ropes to the eyelets round the edge of the liner. Pass the ropes over the rim of the tank. Directing operations from a ladder, position and number the rope controllers.

26. Start lifting the liner from the inside, with the slack being taken up by the controllers on the outside to prevent it dropping back. Do not attempt to pull the liner up by heaving on the ropes from the outside.

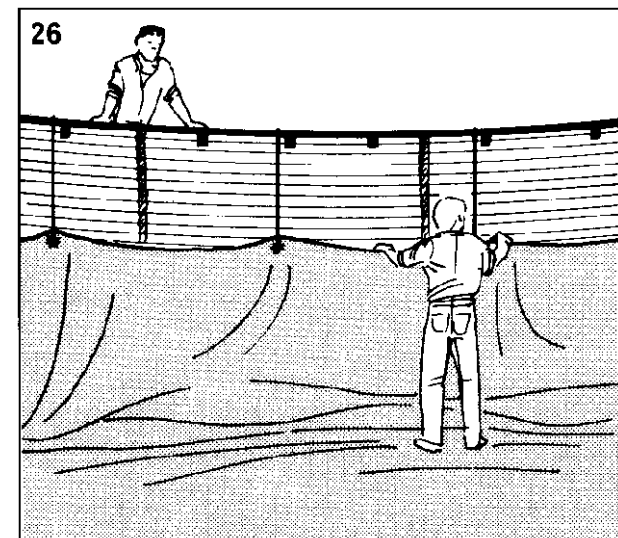
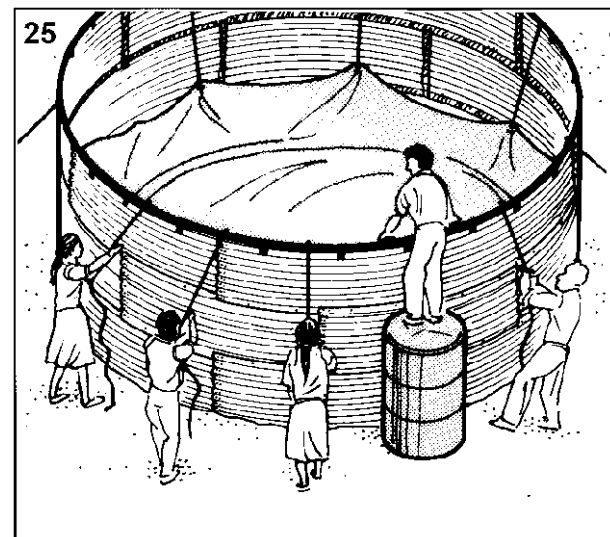
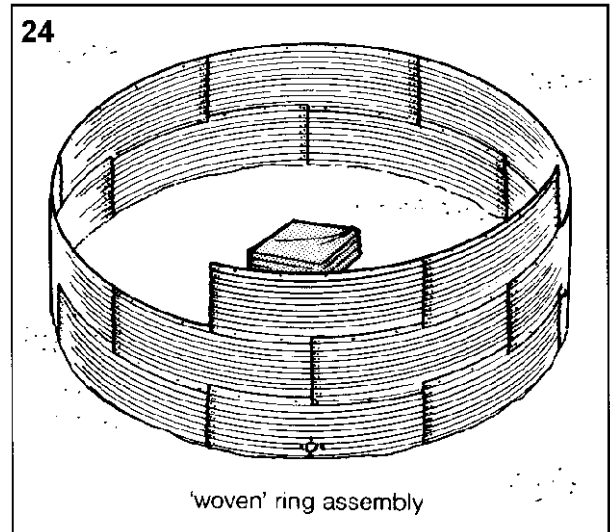

27. Continue to lift the liner, working from a platform of about half the height of the tank, taking care to protect the liner from the pressure of the platform. Continue until the liner has passed over the top and a short distance down the outside.

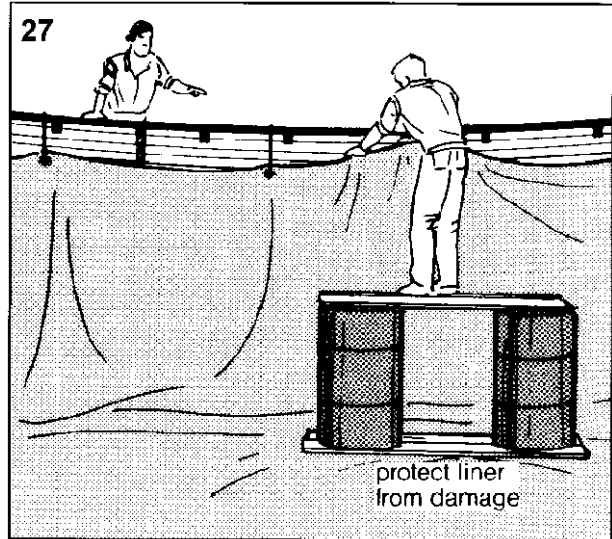

28. Secure the liner in position with the plastic capping and spring clips. Release the control ropes progressively

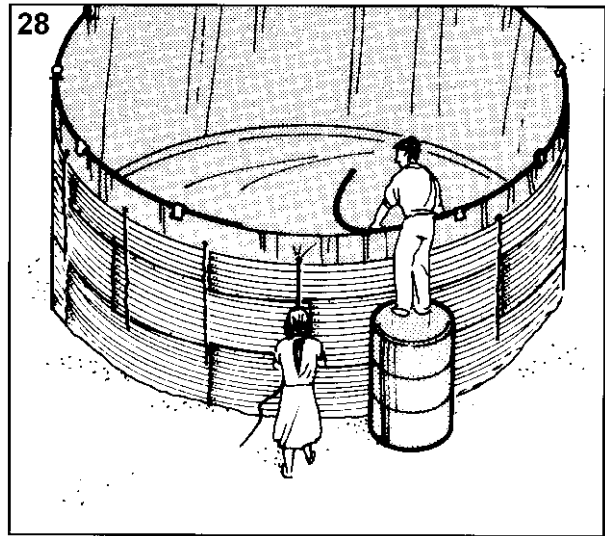

29. When the tank is complete, the liner seams should hang vertically and not stretch when the floor/wall seam is pushed into the corner.

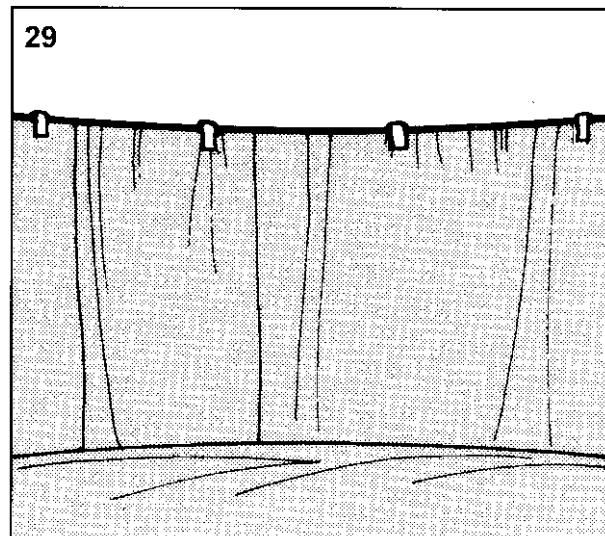

Additional erection instructions for 11m³ tank

30. Select site firm enough to support full tank. Ensure site is level since the smaller diameter of this tank makes it slightly less stable than the larger tank. 2 sheets are provided with 1 outlet/inlet hole in each, whilst another 2 sheets are provided with 2 outlet/inlet holes both of which are blanked off with a moveable steel plate. The number of holes required depends upon the intended use of the tank; if just for plain water storage then just use 3 holes for tank outlet, overflow, washout, outlet as per the larger tanks; if for roughing filtration or upflow clarification refer to the appropriate manuals for instructions.

The roof design for the T11 tank is different from that used on the larger Oxfam tanks and is based upon a metal frame. The next two diagrams show how this design is to be assembled.

31. Assemble the metal roof frame on the ground and lift it into position with the hook ends locating over the tank perimeter capping. Take care to ensure no damage is caused to the tank liner while fitting the frame.

32. Lift the cover over the metal frame and disc upstand and secure in position with rope through eyelets and around retaining eye nuts.

The overflow arrangement for this tank is made using the 3" hose connector (F) and the 4m length of 90mm flexible hose.

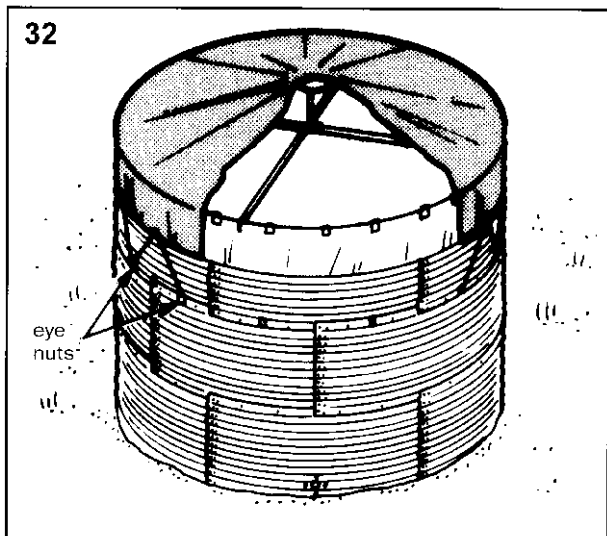
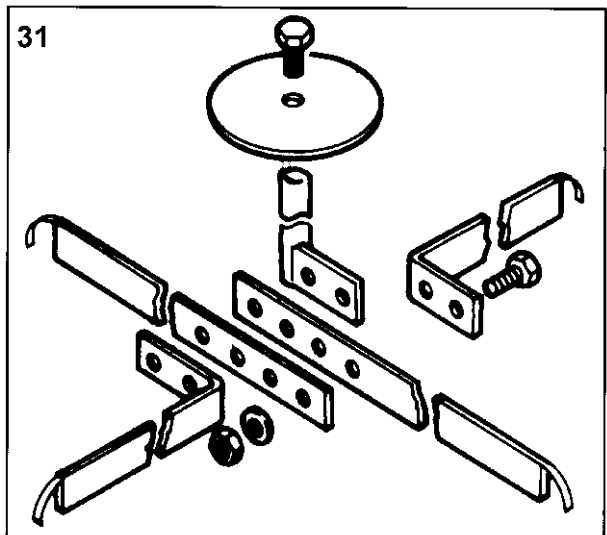
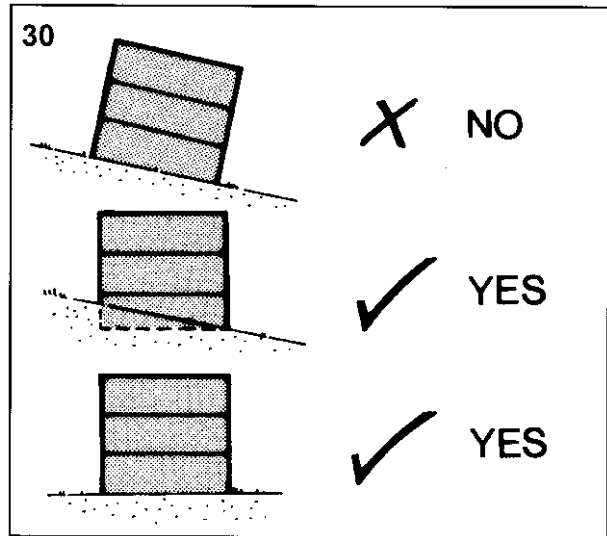

SECTION C - OPERATIONAL INFORMATION

Rapid response PVC tanks

Filling

Before filling the bladder tank, care should be taken to ensure that it is free to fill without restriction. If the ball valve is being used, ensure this is open and open vent cap to ensure safe filling. Support filling hose if used and continue filling until the surface of the tank is hard when firmly slapped. When filling is complete close the ball valve, disconnect or remove hose and close the vent cap. Tighten down restraints where appropriate, making sure they are taut but without putting additional pressure on the tank. Finally conduct an inspection of the tank for leaks. Open delivery valve as required. Don't walk over the tank when empty whilst wearing shoes.

Cleaning

Hot water and hot air can be used where appropriate. Neither should exceed 70°C. Normally a mild cleaning agent can be used to clean the tanks. Allow the solution to stand for at least two hours to kill any bacteria. For stubborn stains or biological contamination an alkaline cleaning fluid can be used to a maximum pH11. Cleaning by abrasion rather than wiping should be avoided.

Storage

Before putting any tank into storage inspect carefully for punctures, major abrasions, weld failures and insecure/damaged fittings. Repair as required. Clean tank thoroughly and allow to dry before packing up. Whilst packing the bladder tanks, carefully roll the ends of the tanks into the centre, ensuring that all debris is removed from the tank surface during the folding operation. For the onion tank, fold the tank $\frac{3}{4}$ of the way across, and then fold back to meet the edge of the first fold. Roll this tube shape, which should be about 1.2m wide, into a cylindrical shape and put in bag.

Oxfam tanks

Commissioning

As soon as possible after completion, the tanks should be filled to stabilise them against the elements, and to check for leaks. Note that it is important to keep tanks permanently held down with guy ropes, to ensure stability in windy conditions. Alternatively, or even additionally, soil should be banked up against the outside of the tank to one third the height of the tank, to give support and stability. Nearly empty tanks without any such restraint have been blown away in the past, so do not neglect these measures.

The roof is important, not only to prevent dust and rain entering the tank, but also to protect the liner from the sun and to prevent wind lifting the liner from a completely empty tank.

Alternative draw-off arrangements

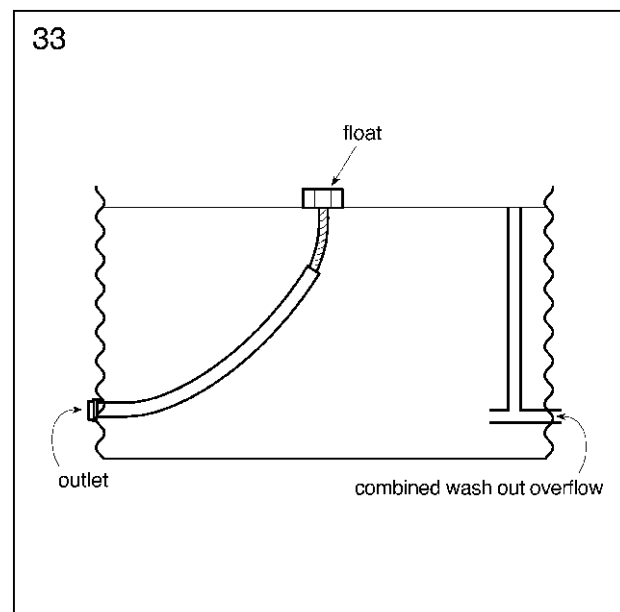

33. If settling water with a high concentration of suspended sediment, a layer of sludge will accumulate in the bottom of the tank. The clean-water outlet is then best connected to a length of green flexible hose, hanging from a float. This will reduce flow, but it has the benefit of keeping discharge flow more uniform. The other low-level hole is then used only for desludging. Alternatively, the outlet hole sheet can be fitted

upside down, so that the flange outlet is then 175mm below the top of the bottom ring.

Operational considerations

The operation of water storage tanks needs to give consideration to how/when they are filled and when people are likely to need water supply – typically early in the morning and late afternoon/evening. Where small tanks are supplied by truck, perhaps with only one tank in each location, it may be best to provide operators only during filling of tanks and then allow water to be available only at certain defined times. If storage tanks are centralised and form the final part of a water treatment system, then permanent operators may need to be employed to run pumps, operate the water treatment system, as well as to ensure the tanks are being filled and that water is available for distribution.

A typical daily operational pattern for all storage systems will be as follows:

- Early morning filling of tank in readiness for morning peak demand.
- Tank empties as morning water is collected (if water is only to be supplied at peak times, tank valve should be opened now and closed at end of period).
- Throughout the day, further filling of tank to have tank full in readiness for evening peak demand.
- Tank empties during evening collection period (if water is only to be supplied at peak times tank valve should be opened now and closed at end of period).
- Late evening/night tank is filled in readiness for morning peak demand.

The users of the system should always be kept informed of when water is to be available and, if problems occur with supply, people should be notified of how long it will be before supply is resumed. While written sign boards can be useful to provide this information, many people, especially women, the traditional collectors of water in many places, may not be able to read. Verbal communication, perhaps through hygiene promoters, will be necessary in such areas. Arrangements should be made to undertake this.

Ensure that tanks have their roofs kept in use to prevent debris falling into the water supply. Where unauthorised people, children or animals

may gain access to the tanks, the area should be fenced off. Finally, where operations need to be conducted at night, the security of operators should be considered, as well as their ability to perform their task during times when they would normally be asleep.

Operational problems

Mechanical damage to the liner is the only likely problem. This will require the tank to be drained to allow a patch (from the repair kit provided) to be applied to perfectly dry rubber. If the base leaks, baling will be necessary to remove the last 50mm of water.

Erosion of the soil into which the rings are set can undermine the liner and threaten stability. Unexpected overflows must be avoided. If the tank must be drained, lay the discharge pipe-work well clear of it. By operating the valves, some water may be diverted into an emptier tank.

Never let petroleum products contaminate the liner, since they will dissolve it.

To minimise risk of damage, storage-tank installations should be fenced to prevent unauthorised access, and a drainage channel should be dug outside the fence to divert any surface run-off from heavy rain away from the tanks.

The Tank Roof Kit is not designed to withstand snowfalls, which will cause substantial damage to both the roof and the tank. The roof cover should be removed during the snow fall seasons. Alternatively a galvanised steel roof capable of supporting 300mm of snow can be specially ordered. The use of wooden box outs for valves that will be exposed during sub-zero conditions will help prevent these from freezing, provided water is drained out of the system at night/when not in use. It is unlikely that the Oxfam tanks themselves will need insulation as only the top of water stored will freeze. Greater care should be taken with PVC rapid response tanks as these are harder to protect from freezing conditions.

Isolating individual tanks for cleaning or repair

34. The layout in the diagram illustrates how a group of three tanks linked together allows isolation and draining of any single tank, without the need to drain other tanks. Five gate valves are required for this arrangement; three of these can be found in the tank liner kit and another two are provided in the tank fittings kit.

Making Oxfam tank installations more permanent

35. Where Oxfam tanks are likely to be in service for more than 12 months, it is suggested that upgrading is undertaken to increase the permanency of the installations. Tank mounds should be reinforced with masonry walling. In addition the tank base and wall can be thickened and strengthened by applying a ferrocement skim to both inside and outside of the tanks and on top of the liner base.

Storage and reuse of tanks

Where it is proposed to store any of the tanks for a period of time either before use or after use, storage facilities and boxing of kits should be suitable to ensure that rats are not able to get inside boxes and damage the liner material. Where tanks are stored for long periods of time, rats have caused much damage and this often only becomes apparent when the tanks are brought out for use.

All of these tanks are designed for re-use and thus can be dismantled and packed away as required. However particularly with the Oxfam tanks, which have numerous components and some consumable materials such as PTFE and self adhesive tape for tank joints, dismantling will have to be conducted with care. All items should be checked back into boxes and ticked off against the original packing list and items replaced as required to make up a complete kit.

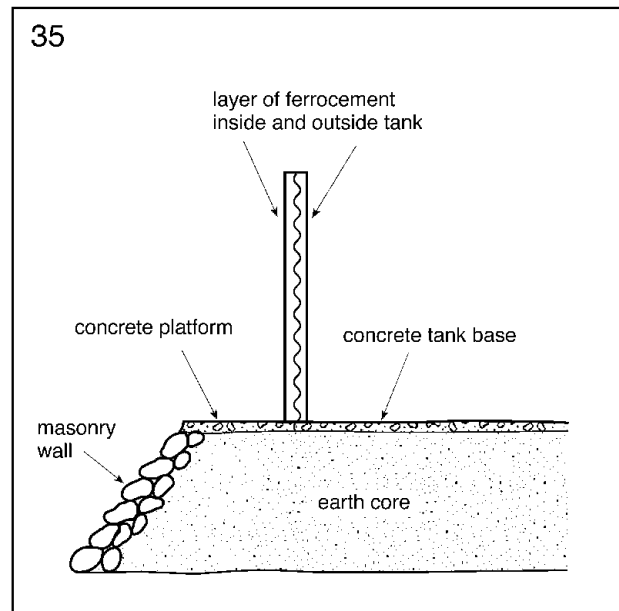
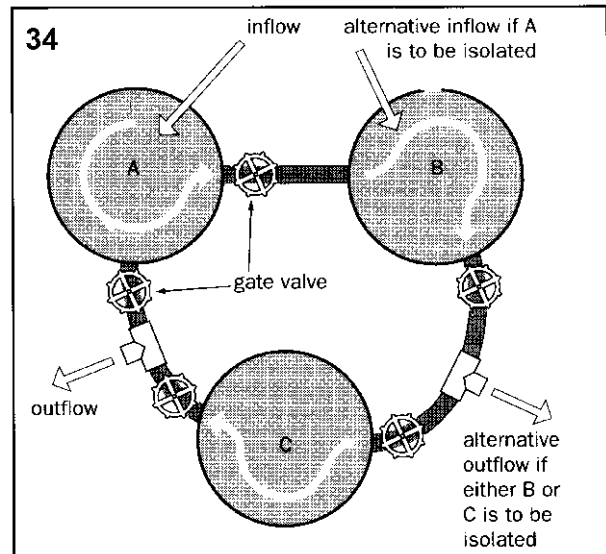

SECTION D-- DETAILS OF KITS AND SUPPLIERS

Full list of kit contents

10m³ Ground Bladder PVC tank

Oxfam code TBT10

(approximate gross weight 118kg and volume 1.0m³), containing:

One food quality PVC bladder tank 10m³ with 4" captive screwed cap for storage of treated water, fitted with:

Item	Qty	Description
1.	1	3" External BSP Male stub fitting
2.	1	3" Female Gate Valve,
3.	1	3"M to 1"F BSP Hex Reducing Bush, GI
4.	1	Groundsheet.
5.	1	Repair kit – no glue supplied
6.	1	Set of instructions.

30m³ Onion PVC tank

Oxfam code TRR30

(approximate gross weight 191kg and volume 1.85m³), containing:

One Onion tank 30m³, self-supporting open topped, manufactured from food quality PVC. Measuring: 5.5m base dia x 4.6m top dia x 1.5m height, Fitted with:

Item	Qty	Description
1.	2	3" BSP male external stubs fitted (opposite each other) each fitted with 3" BSP female gate valve
2.	2	3" BSP female internal stubs (fitted back to back with Item 1. Anti chafe patches and flaps (PVC).
3.	2	Extra stub patches.
4.	1	Cover, food quality PVC with fixing hasps.
5.	1	Groundsheet.
6.	1	Repair kit
7.	1	Set of instructions.
8.	1	Holdall.
9.	2	3" M x 1" F BSP Hex Reducing Bush - GI

6m³ Trucking bladder PVC tank

Oxfam code TRT6

(approximate gross weight 82kg and volume 0.46m³), containing:

One bladder tank 6m³ for trucking manufactured from food quality PVC.
Measuring: 4m length x 2.2m width x 0.65m high (6 tonne maximum)

Item	Qty	Description
1.	5	Heavy duty 50mm polyester webbing with becketed eye loops and 2 x 50mm heavy duty webbing straps (2 each end) with becketed eye loops for securing basis 14 per unit.
2.	3	Overpressure relief valves (2 psi) automatic c/w rubber attached plug.
3.	2	3" BSP male stub fitting (both at the same end), each fitted with 3" BSP female gate
4.	2	Anti chafe patches and covers.
5.	1	Groundsheet.
6.	1	Repair kit.
7.	1	Set of instructions.
8.	1	Holdall.

11m³ Storage Tank Kit

Oxfam code T11 – Tank sheets, liner and roof

(approximate gross weight 350kg and volume 1.1m³), containing:

Item	Qty	Description
1.	14	Corrugated, galvanised steel sheets curved to radius 1.3m, measuring 1.51m long (1.36m effective length) x 0.81m high.
2.	2	Sheets as Item 1, but one hole drilled 95mm Ø for receiving a 3" Table D/E flanged spigot
3.	2	Sheet as Item 1, but two holes drilled 95mm for receiving 3" Table D/E flanged spigots. Sheet to have holes blanked off with plates of corrugated steel
4.	1	8.5m length of 25mm split plastic capping
5.	1	8.5m length of 12mm split plastic capping
6.	25	25mm steel spring clips
7.	1	Bag containing: 300 nuts bolts and washers
8.	2	3" BSP (F) brass gate valve
9.	1	55m roll 50mm wide cloth-based, self-adhesive tape
10.	1	3" M to 1" F GS reducing bush
11.	3	3" (F) threaded flange, Table D/E.
12.	3	3" Table D/E flange welded to 90mm long 3" Ø pipe threaded 40mm.
13.	12	M16 steel studs 100mm long each complete with 2 nuts and 2 washers.
14.	6	3" BS Table D/E full face synthetic rubber gaskets.
15.	1	1.25mm thick reinforced rubber tank liner
16.	1	Repair Kit for Item 15. comprising: 1m ² EPDM material, roll of tape
17.	2	12m rolls PTFE jointing tape
18.	2	17mm open ended podger/spanners
19.	1	3" Ø BSP (F) malleable iron hose connector to fit 90mm hose.
20.	1	Hose clip, bolt type, for 90mm hose
21.	4m	90mm reinforced, non-collapsible flexible hose
22.	50m	6mm polypropylene rope ultra-violet stabilised

23.	6	Pegs 450mm x 10mm
24.	1	OXFAM Water Storage Pack Manual
25.	100m	6mm polypropylene rope, uv-stabilised
26.	12	Eye nuts, eye metal having circular cross section, M10 bolts
27.	3.2	reinforced, conically shaped to suit roof pitch, uPVC cover with hem. Inspection opening provided by having a 400mm-diameter hole with a 600mm square flap.
1	m	
28.	1	Repair kit for uPVC cover comprising: 1m ² uPVC cover material, 1 roll waxed whipping twine, 1 packet of 3 needles
29.	2	1.4m length 50 x 6mm galvanised steel roof frame.
30.	2	1.4m length 50 x 6mm galvanised steel roof frame.
31.	1	0.2m length 50 x 6mm galvanised steel roof frame
32.	1	200mm Ø galvanised steel disc, 3mm thick,
33.	4	M10 Ø x 50mm zinc plated round head bolts, c/w nut and washer

45 m³ Storage Tank Kit

Oxfam code T45L – Tank liner and accessories

(approximate gross weight 238kg and volume 1.2m³), containing:

Item	Qty	Description
1	1	21m length of 12mm Ø split plastic capping
2	1	21m length of 25mm Ø split plastic capping
3	60	25mm Ø steel spring clips
4	1	bag containing 350 M10 Ø x 20mm round head bolts, nuts and washers
5	2	3" Ø BSP (F) brass gate valve
6	2	55m roll 50mm wide cloth-based self-adhesive tape
7	3	3" Ø BSP (F) Table E flange assemblies c/w flanges, gaskets, studs, nuts and washers
8	1	1.4mm thick reinforced EPDM synthetic rubber tank liner
9	1	liner repair kit
10	2	12m roll PTFE joining tape, 12mm wide
11	100m	6mm Ø polypropylene rope, ultra-violet stabilised
12	14	steel pegs 450mm long
13	2	17mm open ended podger/spanner
14	1	OXFAM Water Storage Pack Manual

Oxfam code T45R – Tank roof and accessories

(approximate gross weight 96kg and volume 0.4m³), containing:

Item	Qty	Description
1	1	7.5mm Ø reinforced shaped PVC cover, c/w inspection opening 500mm square.

2	250	6mm polypropylene rope cut into 28 x 5m lengths and fitted to ridge plate
3	2	UPVC 4" column sections, each 1.31m long
4	1	UPVC 4" column connector (socket)
5	28	eye nuts tapped for M10 bolts with 20-25mm Ø eye
6	1	repair kit for PVC cover
7	1	ridge plate with 4" socket attached
8	1	base stand with 4" socket attached

Oxfam code T45S – Tank sheets

(approximate gross weight 250kg and volume 1.39m³), containing:

14 corrugated sheets (three of which are cut and drilled for pipe connections; one has blanking plate fitted).

70 m³ Storage Tank Kit

Contents identical to the 45,000-litre tank kit, except for:

Oxfam code T70L – Tank liner and accessories

(approximate gross weight 275kg and volume 1.0m³)

- 560 M10 bolts, nuts, and washers
- 3 rolls of self-adhesive tape
- a larger rubber liner with eyelets spaced at 1m centres around rim

Oxfam code T70R – Tank roof and accessories

(approximate gross weight 104kg and volume 0.4m³)

- one additional length of 4" column section, 0.75m long
- one additional 4" column connector
- 300m of 6mm rope

Oxfam code T70S – Tank sheets

(approximate gross weight 360kg and volume 1.4m³), containing:

21 corrugated sheets (three of which are cut for flange connections; one has blanking plate fitted).

95 m³ Storage Tank Kit

Contents identical to the 45,000 – litre tank kit, except for:

Oxfam code T95L – Tank liner and accessories

(approximate gross weight 303kg and volume 1m³).

- 780 M10 bolts, nuts, and washers
- 3 rolls of self-adhesive tape
- a larger rubber liner with eyelets spaced at 1m centres round rim

Oxfam code T95R – Tank roof and accessories

(approximate gross weight 107kg and volume 0.4m³)

- 2 additional lengths of 4" column section, 0.75m long
- 2 additional 4" column connectors
- 300m of 6mm rope

Oxfam code T95S – Tank sheets

(approximate gross weight 481kg and volume 1.4m³), containing:

28 corrugated sheets (three of which are cut for flange connections; one has blanking plate fitted).

Tank Fitting kit**Oxfam code TF**

(approximate gross weight 60kg and volume 0.11m³), containing:

Item	Qty	Description
1	2	3" BSP (F) GS tees
2	13	3" BSP (M) threaded GS nipples
3	2	3" BSP (F) threaded GS caps
4	10	3" BSP (F) 90mm hose connectors
5	12	hose clips (bolt type) for 90mm hose
6	2	3" BSP (M) to 3" compression joint PVC coupling
7	1	3" BSP (F) GS 90° elbow
8	1	3" PVC pipe 500mm long, BSP (M) threaded one end
9	1	30m coil of 90mm (3") flexible hose
10	2	3" BSP (F) brass gate valve
11	5	rolls of PTFE tape

Additional kits as listed below, though not part of the storage equipment package, can be ordered as required.

Site tool kit**Oxfam code OS**

(approximate gross weight 80kg and volume 0.15m³), containing:

A range of tools for erecting tanks, laying pipes etc.

Scaffolding tower**Oxfam code OT**

(approximate gross weight 109kg and volume 0.7m³), containing:

1 climber tower with platform, total height 3.5m.

Ladder for tank erection**Oxfam code OL**

(approximate gross weight 16kg and volume 0.25m³), containing;

1 aluminum ladder, double extension push-up type, total extended length 4.2m.

List of suppliers used by Oxfam (based in the United Kingdom)

The "Oxfam" Water Storage tanks, codes T11, T45, T70, T95, are supplied by:

Butyl Products Ltd, 11 Radford Crescent, Billericay, Essex, CM12 0DW
Tel (01277) 653281; Fax (01277) 657921

Even Products Ltd, Oxtalls Farm, Evesham, Worcs, WR11 4TS
Tel (01386) 41212; Fax (01386) 765404

The rapid response tanks, codes TBT10, TRR30, TRT6, are supplied by:

Crestbury Ltd – Auto Marine, Hempstead road, Holt, Norfolk, NR22 6DL
Tel (01328) 852300

The Tank Fittings Kit, code TF, is supplied by:

Even Products (as above)

Akro Valve Co, Unit 2, Chaucer Industrial Estate, Dittons Road, Polegate, East Sussex
Tel: (01323) 485272; Fax: (01323) 485273

The Site Tool kit, and Ladder, codes OS and OL, are supplied by:

Kennedy Group Ltd, Wigston Works, Victoria Street, Wigston, Leicester, LE8 1AJ
Tel (0116) 2888777; Fax (0116) 2812393

The Scaffolding Tower is supplied by, code OT:

Lyte Industries Ltd, Wern Industrial Estate, Rogerstone, Newport, Gwent NP1 9YL
Tel: (01633) 892222; Fax: (01633) 896480